



Chipsmall Limited consists of a professional team with an average of over 10 year of expertise in the distribution of electronic components. Based in Hongkong, we have already established firm and mutual-benefit business relationships with customers from,Europe,America and south Asia,supplying obsolete and hard-to-find components to meet their specific needs.

With the principle of “Quality Parts,Customers Priority,Honest Operation,and Considerate Service”,our business mainly focus on the distribution of electronic components. Line cards we deal with include Microchip,ALPS,ROHM,Xilinx,Pulse,ON,Everlight and Freescale. Main products comprise IC,Modules,Potentiometer,IC Socket,Relay,Connector.Our parts cover such applications as commercial,industrial, and automotives areas.

We are looking forward to setting up business relationship with you and hope to provide you with the best service and solution. Let us make a better world for our industry!



Contact us

Tel: +86-755-8981 8866 Fax: +86-755-8427 6832

Email & Skype: info@chipsmall.com Web: www.chipsmall.com

Address: A1208, Overseas Decoration Building, #122 Zhenhua RD., Futian, Shenzhen, China





LC75814V

1/4 Duty General-Purpose LCD Driver



An ON Semiconductor Company

Overview

The LC75814V is a 1/4 duty general-purpose LCD driver that can be used for frequency display in electronic tuners under the control of a microcontroller. The LC75814V can drive an LCD with up to 64 segments directly. The LC75814V can also control up to 4 general-purpose output ports. Since the LC75814V uses separate power supply systems for the LCD drive block and the logic block, the LCD driver block power-supply voltage can be set to any voltage in the range 2.7 to 6.0 volts, regardless of the logic block power-supply voltage.

Features

- Support for 1/4 duty 1/2 bias or 1/4 duty 1/3 bias drive of up to 64 segments under serial data control.
- Serial data input supports CCB format communication with the system controller.
- Serial data control of the power-saving mode based backup function and all the segments forced off function
- Serial data control of switching between the segment output port and the general-purpose output port functions
- High generality, since display data is displayed directly without decoder intervention.
- Independent V_{LCD} for the LCD driver block (V_{LCD} can be set to any voltage in the range 2.7 to 6.0 volts, regardless of the logic block power-supply voltage.)
- The \overline{INH} pin can force the display to the off state.
- RC oscillator circuit

Package Dimensions

unit: mm

3191A-SSOP30

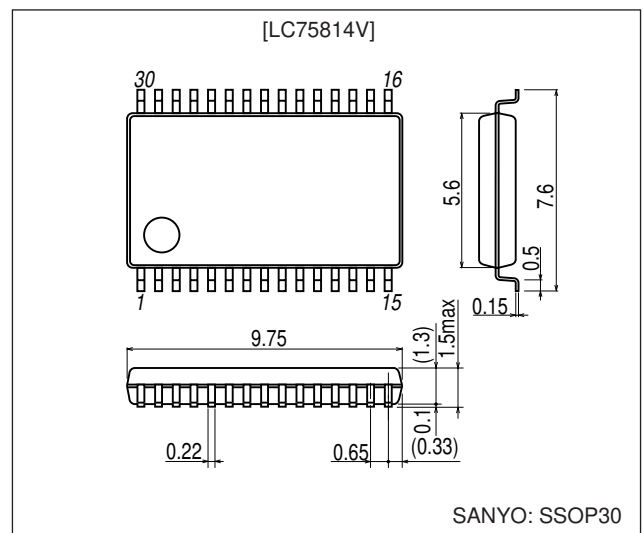

- CCB is a trademark of SANYO ELECTRIC CO., LTD.
- CCB is a SANYO's original bus format and all the bus addresses are controlled by SANYO.

- Any and all SANYO products described or contained herein do not have specifications that can handle applications that require extremely high levels of reliability, such as life-support systems, aircraft's control systems, or other applications whose failure can be reasonably expected to result in serious physical and/or material damage. Consult with your SANYO representative nearest you before using any SANYO products described or contained herein in such applications.
- SANYO assumes no responsibility for equipment failures that result from using products at values that exceed, even momentarily, rated values (such as maximum ratings, operating condition ranges, or other parameters) listed in products specifications of any and all SANYO products described or contained herein.

LC75814V

Specifications

Absolute Maximum Ratings at Ta = 25°C, VSS = 0 V

Parameter	Symbol	Conditions	Ratings	Unit
Maximum supply voltage	V _{DD max}	V _{DD}	-0.3 to +7.0	V
	V _{LCD max}	V _{LCD}	-0.3 to +7.0	V
Input voltage	V _{IN 1}	CE, CL, DI, $\overline{\text{INH}}$	-0.3 to +7.0	V
	V _{IN 2}	OSC	-0.3 to V _{DD} + 0.3	V
	V _{IN 3}	V _{LCD 1} , V _{LCD 2}	-0.3 to V _{LCD} + 0.3	V
Output voltage	V _{OUT 1}	OSC	-0.3 to V _{DD} + 0.3	V
	V _{OUT 2}	S1 to S16, COM1 to COM4, P1 to P4	-0.3 to V _{LCD} + 0.3	V
Output current	I _{OUT 1}	S1 to S16	300	μA
	I _{OUT 2}	COM1 to COM4	3	mA
	I _{OUT 3}	P1 to P4	5	mA
Allowable power dissipation	Pd max	Ta = 85°C	100	mW
Operating temperature	Topr		-40 to +85	°C
Storage temperature	Tstg		-55 to +125	°C

Allowable Operating Ranges at Ta = -40 to +85°C, VSS = 0 V

Parameter	Symbol	Conditions	Ratings			Unit
			min	typ	max	
Supply voltage	V _{DD}	V _{DD}	2.7		6.0	V
	V _{LCD}	V _{LCD}	2.7		6.0	V
Input voltage	V _{LCD1}	V _{LCD1}		2/3 V _{LCD}	V _{LCD}	V
	V _{LCD2}	V _{LCD2}		1/3 V _{LCD}	V _{LCD}	V
Input high level voltage	V _{IH}	CE, CL, DI, $\overline{\text{INH}}$	0.8 V _{DD}		6.0	V
Input low level voltage	V _{IL}	CE, CL, DI, $\overline{\text{INH}}$	0		0.2 V _{DD}	V
Recommended external resistance	R _{OSC}	OSC		43		kΩ
Recommended external capacitance	C _{OSC}	OSC		680		pF
Guaranteed oscillation range	f _{OSC}	OSC	25	50	100	kHz
Data setup time	t _{ds}	CL, DI: Figure 2	160			ns
Data hold time	t _{dh}	CL, DI: Figure 2	160			ns
CE wait time	t _{cp}	CE, CL: Figure 2	160			ns
CE setup time	t _{cs}	CE, CL: Figure 2	160			ns
CE hold time	t _{ch}	CE, CL: Figure 2	160			ns
High level clock pulse width	t _{0H}	CL: Figure 2	160			ns
Low level clock pulse width	t _{0L}	CL: Figure 2	160			ns
Rise time	t _r	CE, CL, DI: Figure 2		160		ns
Fall time	t _f	CE, CL, DI: Figure 2		160		ns
$\overline{\text{INH}}$ switching time	t _c	$\overline{\text{INH}}$, CE: Figure 3	10			μs

Pin Assignment

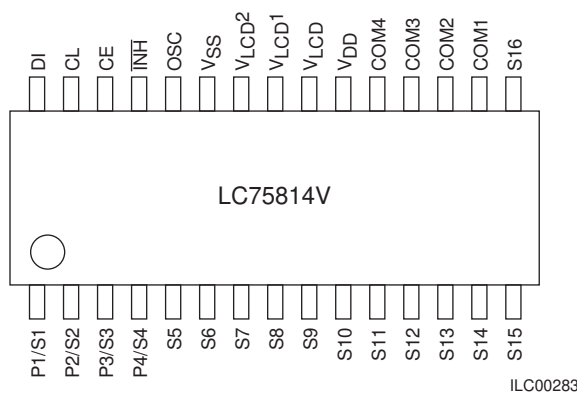

Top view

ILC00283

LC75814V

Electrical Characteristics for the Allowable Operating Ranges

Parameter	Symbol	Conditions	Ratings			Unit
			min	typ	max	
Hysteresis	V_H	CE, CL, DI, $\overline{\text{INH}}$		0.1 V_{DD}		V
Input high level current	I_{IH}	CE, CL, DI, $\overline{\text{INH}}$; $V_I = 6.0$ V			5.0	μA
Input low level current	I_{IL}	CE, CL, DI, $\overline{\text{INH}}$; $V_I = 0$ V	-5.0			μA
Output high level voltage	V_{OH1}	S1 to S16; $I_O = -20$ μA	$V_{LCD} - 0.9$			V
	V_{OH2}	COM1 to COM4; $I_O = -100$ μA	$V_{LCD} - 0.9$			V
	V_{OH3}	P1 to P4; $I_O = -1$ mA	$V_{LCD} - 0.9$			V
Output low level voltage	V_{OL1}	S1 to S16; $I_O = 20$ μA			0.9	V
	V_{OL2}	COM1 to COM4; $I_O = 100$ μA			0.9	V
	V_{OL3}	P1 to P4; $I_O = 1$ mA			0.9	V
Output middle level voltage*1	V_{MID1}	COM1 to COM4; 1/2 bias, $I_O = \pm 100$ μA	$1/2 V_{LCD} - 0.9$		$1/2 V_{LCD} + 0.9$	V
	V_{MID2}	S1 to S16; 1/3 bias, $I_O = \pm 20$ μA	$2/3 V_{LCD} - 0.9$		$2/3 V_{LCD} + 0.9$	V
	V_{MID3}	S1 to S16; 1/3 bias, $I_O = \pm 20$ μA	$1/3 V_{LCD} - 0.9$		$1/3 V_{LCD} + 0.9$	V
	V_{MID4}	COM1 to COM4; 1/3 bias, $I_O = \pm 100$ μA	$2/3 V_{LCD} - 0.9$		$2/3 V_{LCD} + 0.9$	V
	V_{MID5}	COM1 to COM4; 1/3 bias, $I_O = \pm 100$ μA	$1/3 V_{LCD} - 0.9$		$1/3 V_{LCD} + 0.9$	V
Oscillator frequency	f_{OSC}	OSC; $R_{OSC} = 43$ k Ω , $C_{OSC} = 680$ pF	40	50	60	kHz
Current drain	I_{DD1}	V_{DD} ; power saving mode			5	μA
	I_{DD2}	V_{DD} ; $V_{DD} = 6.0$ V, output open, $f_{osc} = 50$ kHz		230	460	μA
	I_{LCD1}	V_{LCD} ; power saving mode			5	μA
	I_{LCD2}	V_{LCD} ; $V_{LCD} = 6.0$ V, output open 1/2 bias, $f_{osc} = 50$ kHz		100	200	μA
	I_{LCD3}	V_{LCD} ; $V_{LCD} = 6.0$ V, output open 1/3 bias, $f_{osc} = 50$ kHz		60	120	μA

Note: *1 Excluding the bias voltage generation divider resistors built in the V_{LCD1} and V_{LCD2} . (See Figure 1.)

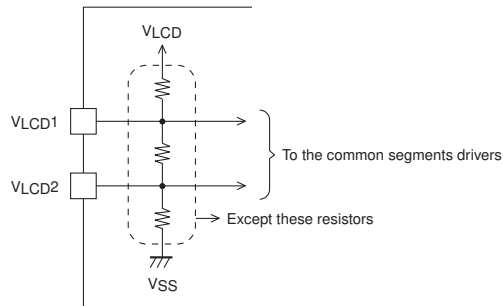

ILC00269

Figure 1

LC75814V

1. When CL is stopped at the low level

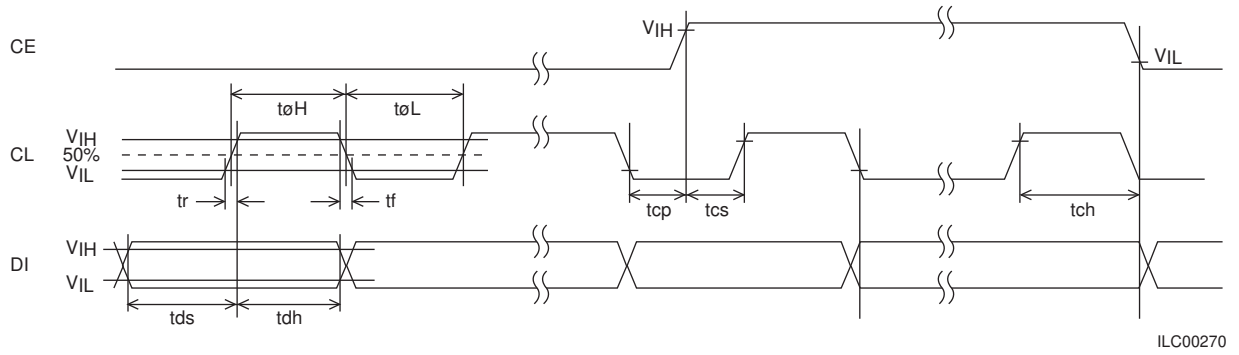

2. When CL is stopped at the high level

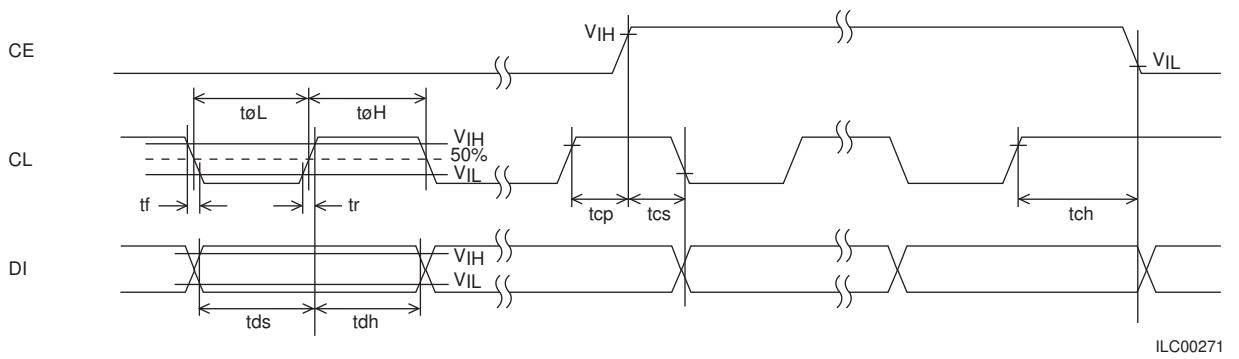
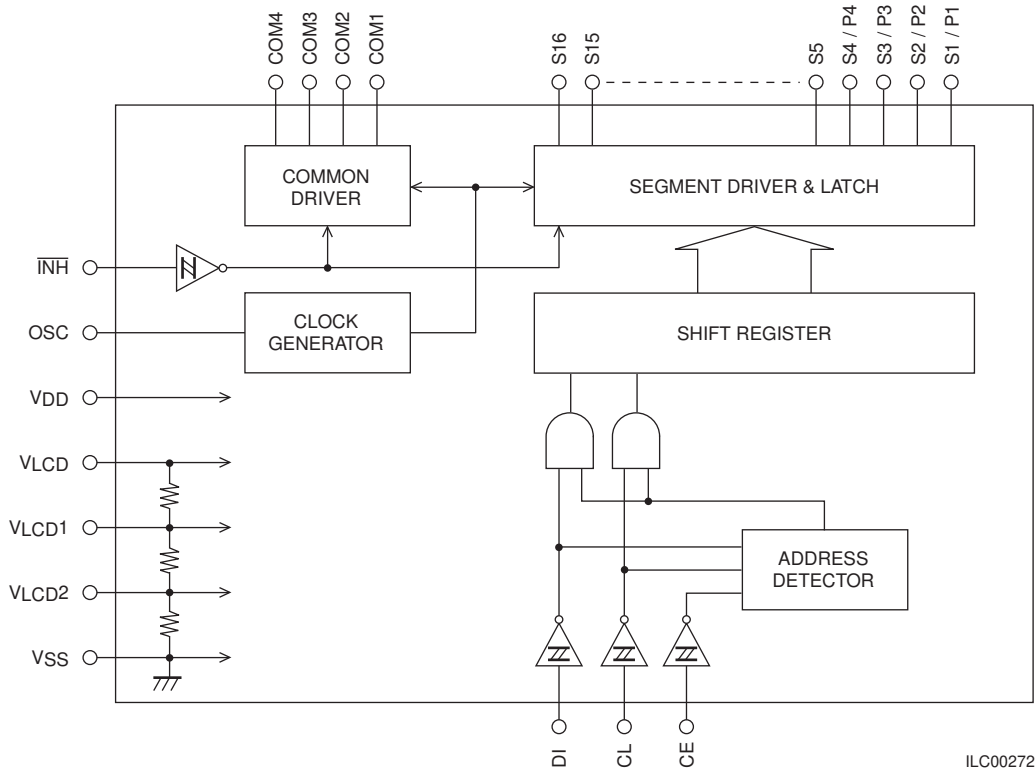

Figure 2

Block Diagram



Pin Functions

Pin	Pin No.	Function	Active	I/O	Handling when unused						
S1/P1 to S4/P4 S5 to S16	1 to 4 5 to 16	Segment outputs for displaying the display data transferred by serial data input. The pins S1/P1 to S4/P4 can be used as general-purpose output ports when so set up by the control data.	—	O	Open						
COM1 COM2 COM3 COM4	17 to 20	Common driver outputs. The frame frequency f_O is given by: $f_O = (f_{OSC}/512)$ Hz.	—	O	Open						
OSC	26	Oscillator connection An oscillator circuit is formed by connecting an external resistor and capacitor to this pin.	—	I/O	V_{DD}						
CE CL DI	28 29 30	Serial data transfer inputs. These pins are connected to the control microprocessor.	<table border="1"> <tr> <td>CE: Chip enable</td> <td>H</td> </tr> <tr> <td>CL: Synchronization clock</td> <td></td> </tr> <tr> <td>DI: Transfer data</td> <td>—</td> </tr> </table>	CE: Chip enable	H	CL: Synchronization clock		DI: Transfer data	—	I	GND
CE: Chip enable	H										
CL: Synchronization clock											
DI: Transfer data	—										
\overline{INH}	27	Display off control input • \overline{INH} = low (V_{SS}): Off S1/P1 to S4/P4 = Low (These pins are forcibly set to the segment output port function and fixed at the V_{SS} level.) S5 to S16 = Low (V_{SS}). COM1 to COM4 = Low (V_{SS}) • \overline{INH} = high (V_{DD}): On Note that serial data transfers can be performed when the display is forced off by this pin.	L	I	GND						
V_{LCD1}	23	Used to apply the LCD drive 2/3 bias voltage externally. This pin must be connected to V_{LCD2} when 1/2 bias drive is used.	—	I	Open						
V_{LCD2}	24	Used to apply the LCD drive 1/3 bias voltage externally. This pin must be connected to V_{LCD1} when 1/2 bias drive is used.	—	I	Open						
V_{DD}	21	Logic block power supply. Provide a voltage in the range 2.7 to 6.0 V.	—	—	—						
V_{LCD}	22	LCD driver block power supply. Provide a voltage in the range 2.7 to 6.0 V.	—	—	—						
V_{SS}	25	Ground pin. Connect to ground.	—	—	—						

Serial Data Transfer Format

1. When CL is stopped at the low level

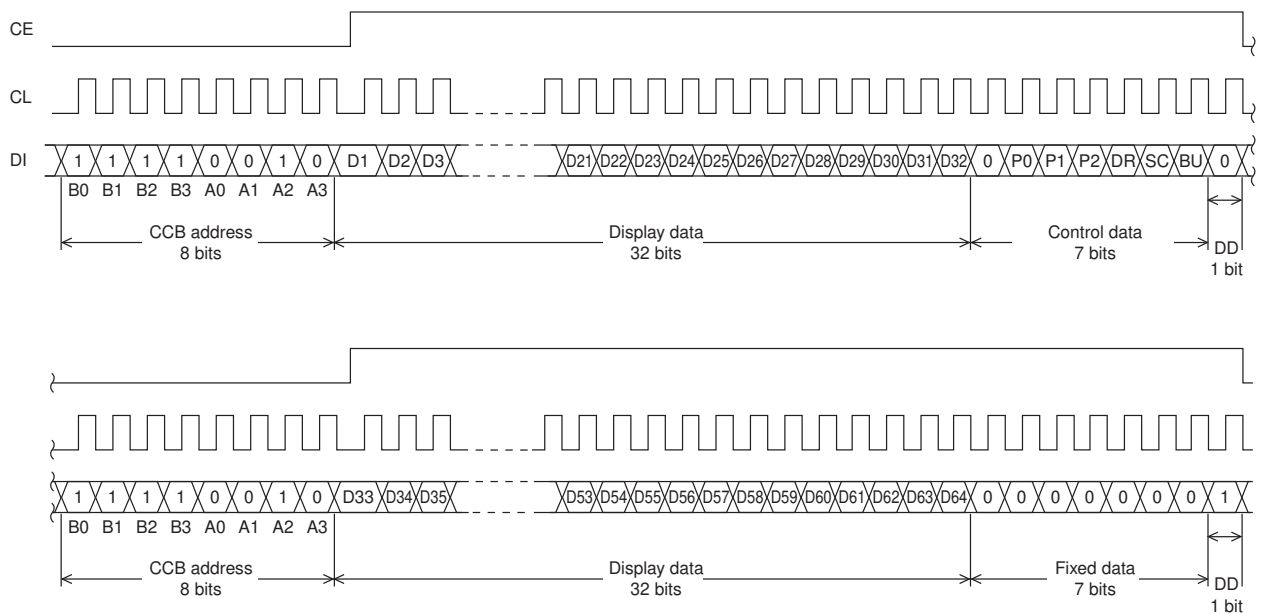

ILC00273

Note: DD ... Direction data

2. When CL is stopped at the high level

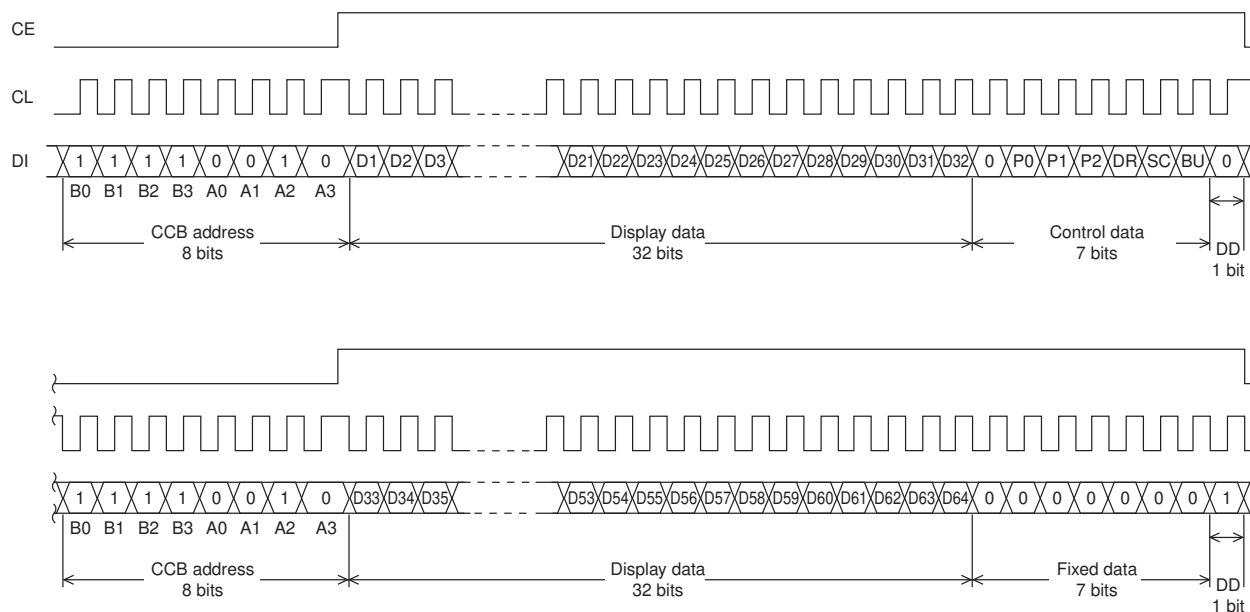

ILC00274

Note: DD ... Direction data

- CCB address.....4FH
- D1 to D64.....Display data
- P0 to P2Segment output port/general-purpose output port switching control data
- DR1/2 bias drive or 1/3 bias drive switching control data
- SC.....Segments on/off control data
- BUNormal mode/power-saving mode control data

Serial Data Transfer Examples

- When 33 or more segments are used, all 80 bits of the serial data must be sent.

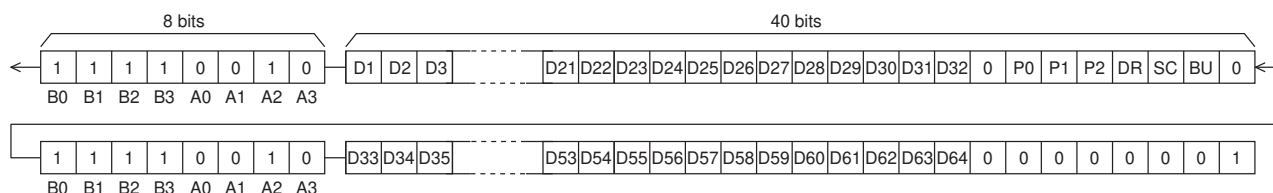

- When fewer than 33 segments are used, only 40 bits of serial data need to be sent. However, the display data D1 to D32 and the control data must be sent.

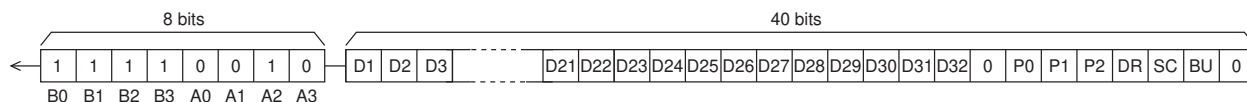

Note: When fewer than 33 segments are used, transfers such as that shown in the figure below cannot be used.

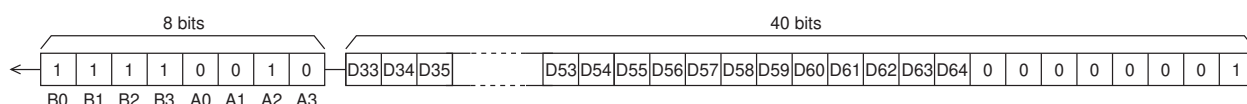

ILC00275

Control Data Functions

1. P0 to P2: Segment output port/general-purpose output port switching control data.

These control data bits switch the S1/P1 to S4/P4 output pins between their segment output port and general-purpose output port functions.

Control data			Output pin states			
P0	P1	P2	S1/P1	S2/P2	S3/P3	S4/P4
0	0	0	S1	S2	S3	S4
0	0	1	P1	S2	S3	S4
0	1	0	P1	P2	S3	S4
0	1	1	P1	P2	P3	S4
1	0	0	P1	P2	P3	P4

Note: Sn (n = 1 to 4): Segment output ports
Pn (n = 1 to 4): General-purpose output ports

Also note that when the general-purpose output port function is selected, the output pins and the display data will have the correspondences listed in the tables below.

Output pin	Corresponding display data
S1/P1	D1
S2/P2	D5
S3/P3	D9
S4/P4	D13

For example, if the output pin S4/P4 has the general-purpose output port function selected, it will output a high level (V_{LCD}) when the display data D13 is 1, and will output a low level (V_{SS}) when D13 is 0.

2. DR: 1/2 bias drive or 1/3 bias drive switching control data

This control data bit selects either 1/2 bias drive or 1/3 bias drive.

DR	Drive type
0	1/3 bias drive
1	1/2 bias drive

3. SC: Segments on/off control data

This control data bit controls the on/off state of the segments.

SC	Display state
0	On
1	Off

However, note that when the segments are turned off by setting SC to 1, the segments are turned off by outputting segment off waveforms from the segment output pins.

4. BU: Normal mode/power-saving mode control data

This control data bit selects either normal mode or power-saving mode.

BU	Mode
0	Normal mode
1	Power saving mode (The OSC pin oscillator is stopped, and the common and segment output pins go to the V_{SS} level. However, the S1/P1 to S4/P4 output pins that are set to be general-purpose output ports by the control data P0 to P2 can be used as general-purpose output ports.)

Display Data to Segment Output Pin Correspondence

Segment output pin	COM1	COM2	COM3	COM4
S1/P1	D1	D2	D3	D4
S2/P2	D5	D6	D7	D8
S3/P3	D9	D10	D11	D12
S4/P4	D13	D14	D15	D16
S5	D17	D18	D19	D20
S6	D21	D22	D23	D24
S7	D25	D26	D27	D28
S8	D29	D30	D31	D32
S9	D33	D34	D35	D36
S10	D37	D38	D39	D40
S11	D41	D42	D43	D44
S12	D45	D46	D47	D48
S13	D49	D50	D51	D52
S14	D53	D54	D55	D56
S15	D57	D58	D59	D60
S16	D61	D62	D63	D64

Note: This applies to the case where the S1/P1 to S4/P4 output pins are set to be segment output ports.

For example, the table below lists the segment output states for the S11 output pin.

Display data				Segment output pin (S11) state
D41	D42	D43	D44	
0	0	0	0	The LCD segments corresponding to COM1 to COM4 are off.
0	0	0	1	The LCD segment corresponding to COM4 is on.
0	0	1	0	The LCD segment corresponding to COM3 is on.
0	0	1	1	The LCD segments corresponding to COM3 and COM4 are on.
0	1	0	0	The LCD segment corresponding to COM2 is on.
0	1	0	1	The LCD segments corresponding to COM2 and COM4 are on.
0	1	1	0	The LCD segments corresponding to COM2 and COM3 are on.
0	1	1	1	The LCD segments corresponding to COM2, COM3 and COM4 are on.
1	0	0	0	The LCD segment corresponding to COM1 is on.
1	0	0	1	The LCD segments corresponding to COM1 and COM4 are on.
1	0	1	0	The LCD segments corresponding to COM1 and COM3 are on.
1	0	1	1	The LCD segments corresponding to COM1, COM3 and COM4 are on.
1	1	0	0	The LCD segments corresponding to COM1 and COM2 are on.
1	1	0	1	The LCD segments corresponding to COM1, COM2 and COM4 are on.
1	1	1	0	The LCD segments corresponding to COM1 to COM3 are on.
1	1	1	1	The LCD segments corresponding to COM1 to COM4 are on.

1/4 Duty, 1/2 Bias Drive Technique

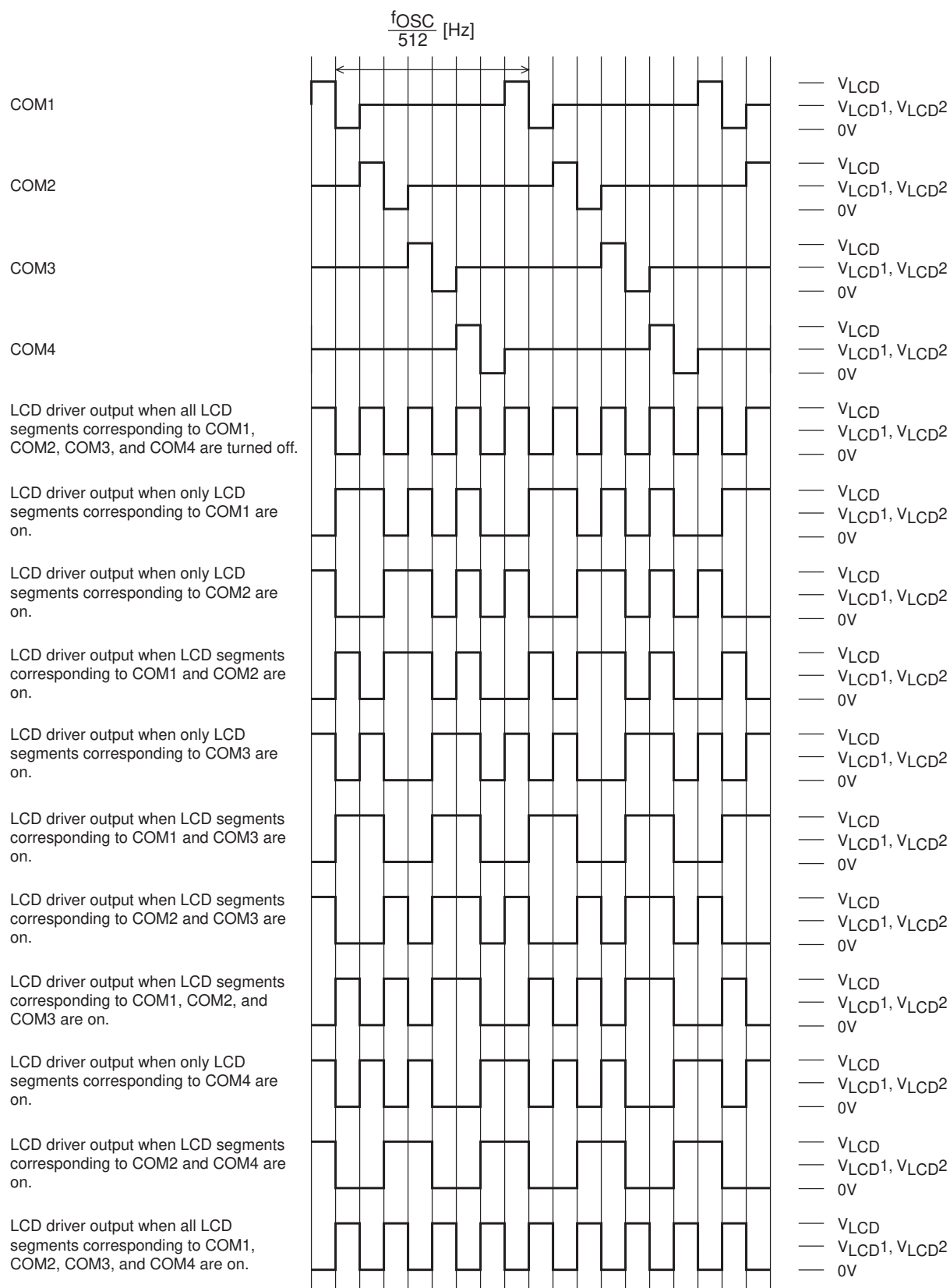

ILC00276

1/4 Duty, 1/2 Bias Waveforms

1/4 Duty, 1/3 Bias Drive Technique

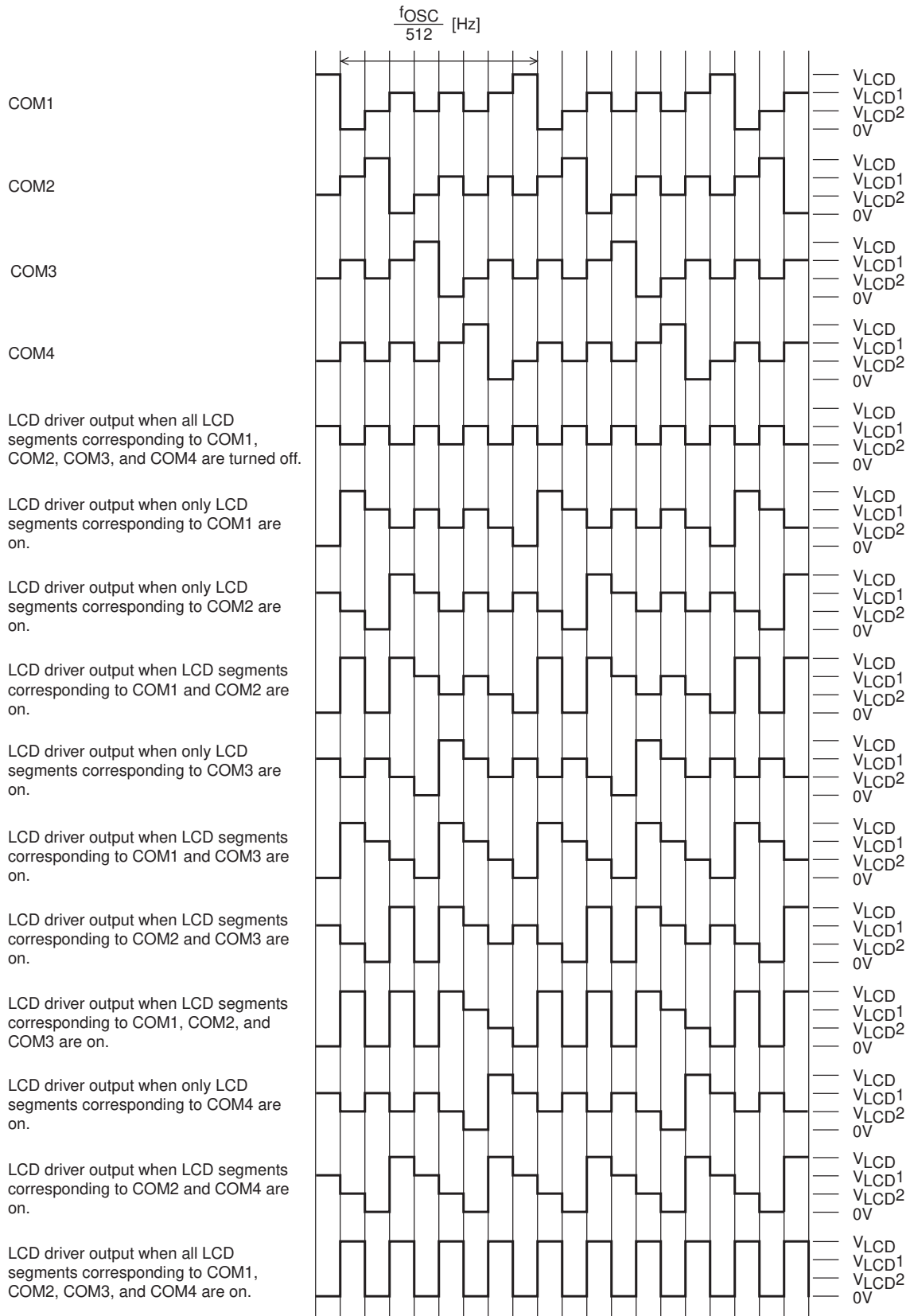

ILC00277

1/4 Duty, 1/3 Bias Waveforms

The $\overline{\text{INH}}$ pin and Display Control

Since the IC internal data (the display data D1 to D64 and the control data) is undefined when power is first applied, applications should set the $\overline{\text{INH}}$ pin low at the same time as power is applied to turn off the display (This sets the S1/P1 to S4/P4, S5 to S16, and COM1 to COM4 to the V_{SS} level.) and during this period send serial data from the controller. The controller should then set the $\overline{\text{INH}}$ pin high after the data transfer has completed. This procedure prevents meaningless displays at power on. (See Figure 3.)

Notes on the Power On/Off Sequences

Applications should observe the following sequence when turning the LC75814V power on and off.

- At power on: Logic block power supply (V_{DD}) on → LCD driver block power supply (V_{LCD}) on
- At power off: LCD driver block power supply (V_{LCD}) off → Logic block power supply (V_{DD}) off

However, if the logic and LCD driver block use a shared power supply, then the power supplies can be turned on and off at the same time.

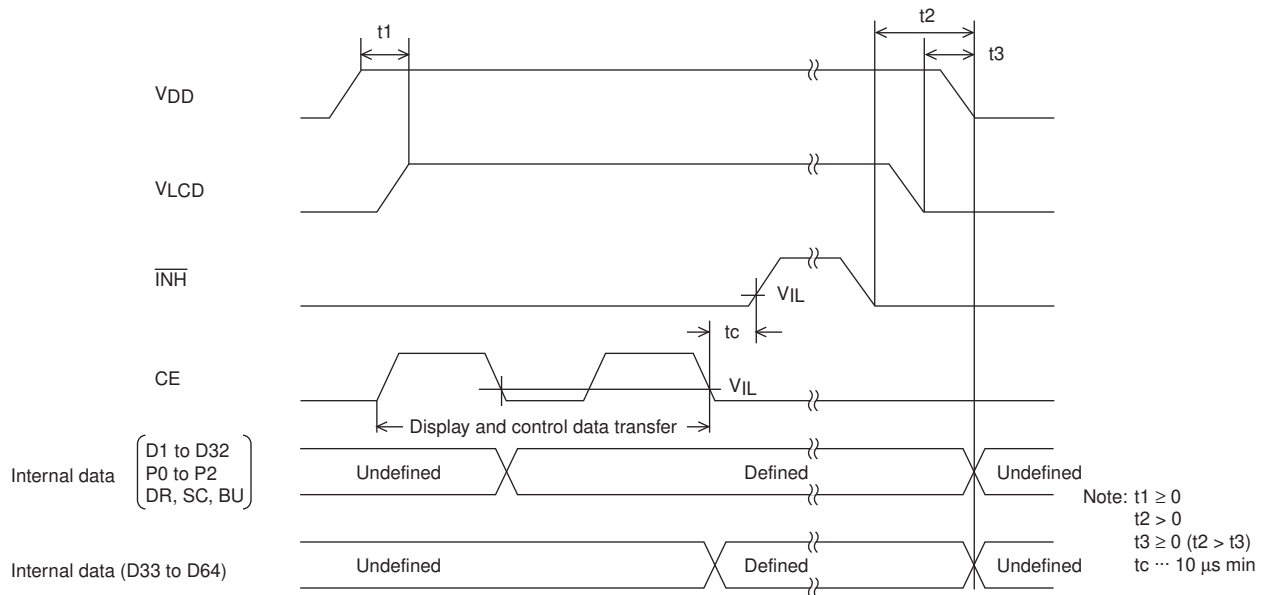

Figure 3

ILC00278

Notes on Controller Transfer of Display Data

Since the LC75814V accept display data (D1 to D64) divided into two separate transfer operations, we recommend that applications transfer all of the display data within a period of less than 30 ms to prevent observable degradation of display quality.

Sample Application Circuit 1

1/2 Bias (for use with normal panels)

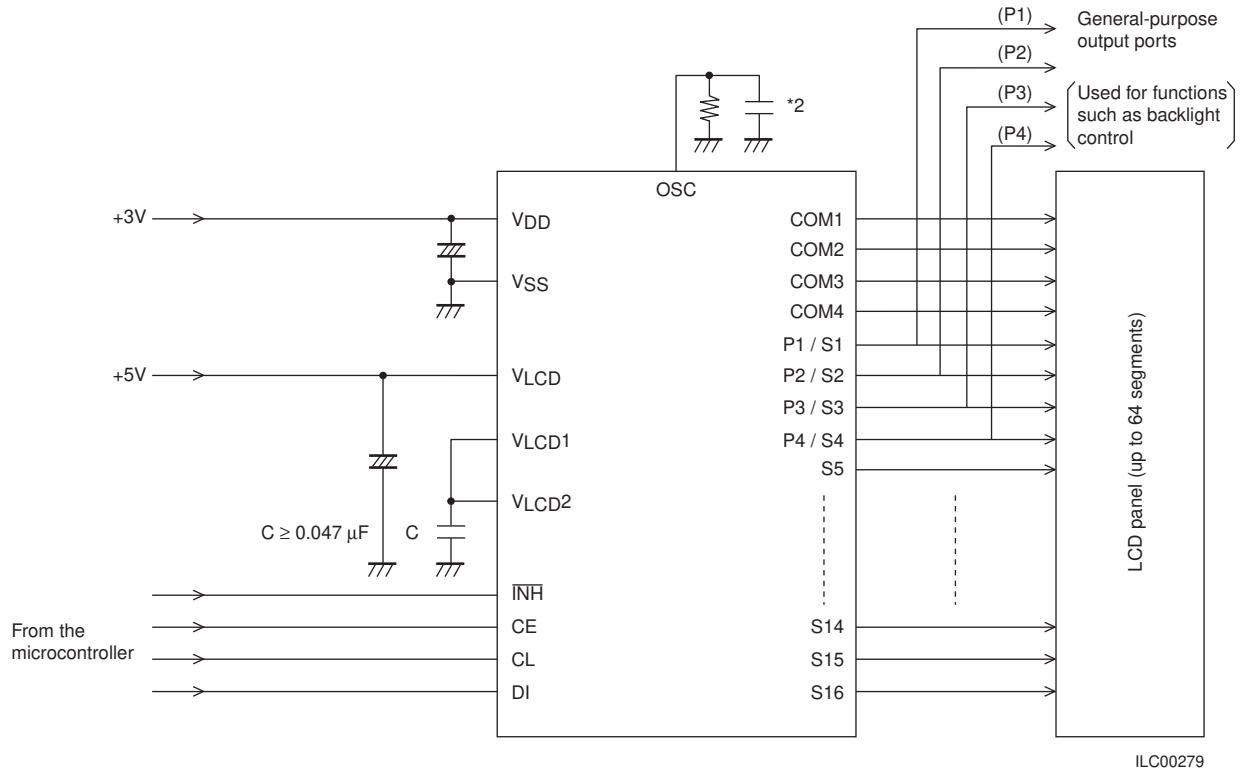

Note: *2 When a capacitor except the recommended external capacitance ($C_{OSC} = 680 \text{ pF}$) is connected the OSC pin, we recommend that applications connect the OSC pin with a capacitor in the range 220 to 2200pF.

Sample Application Circuit 2

1/2 Bias (for use with large panels)

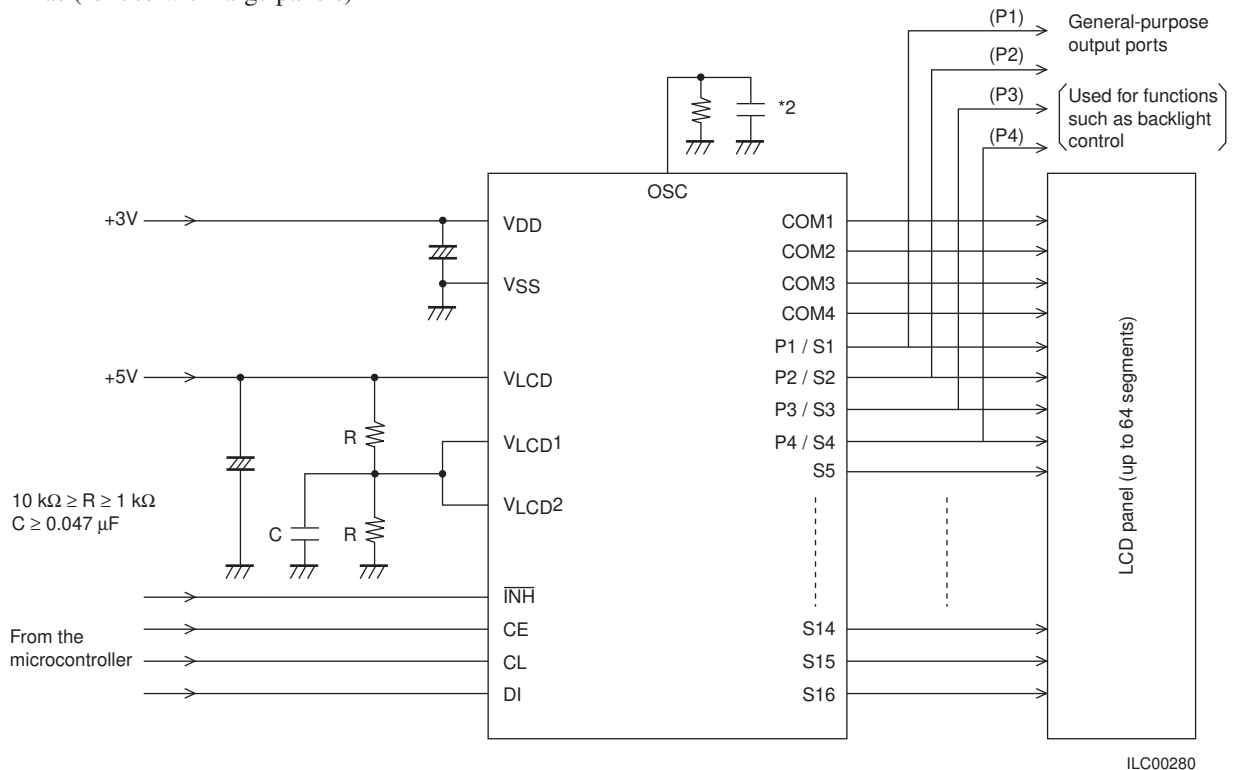

Note: *2 When a capacitor except the recommended external capacitance ($C_{OSC} = 680 \text{ pF}$) is connected the OSC pin, we recommend that applications connect the OSC pin with a capacitor in the range 220 to 2200pF.

Sample Application Circuit 3

1/3 Bias (for use with normal panels)

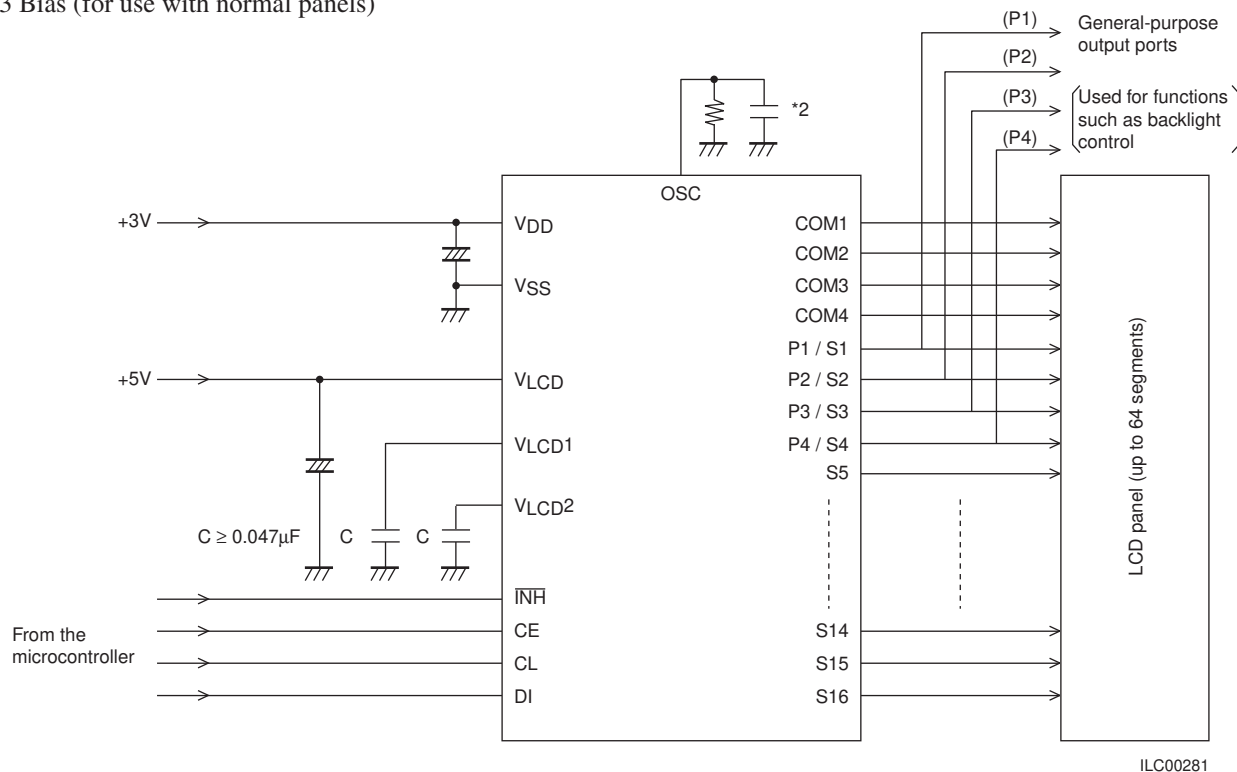

Note: *2 When a capacitor except the recommended external capacitance ($C_{OSC} = 680 \text{ pF}$) is connected the OSC pin, we recommend that applications connect the OSC pin with a capacitor in the range 220 to 2200pF.

Sample Application Circuit 4

1/3 Bias (for use with large panels)

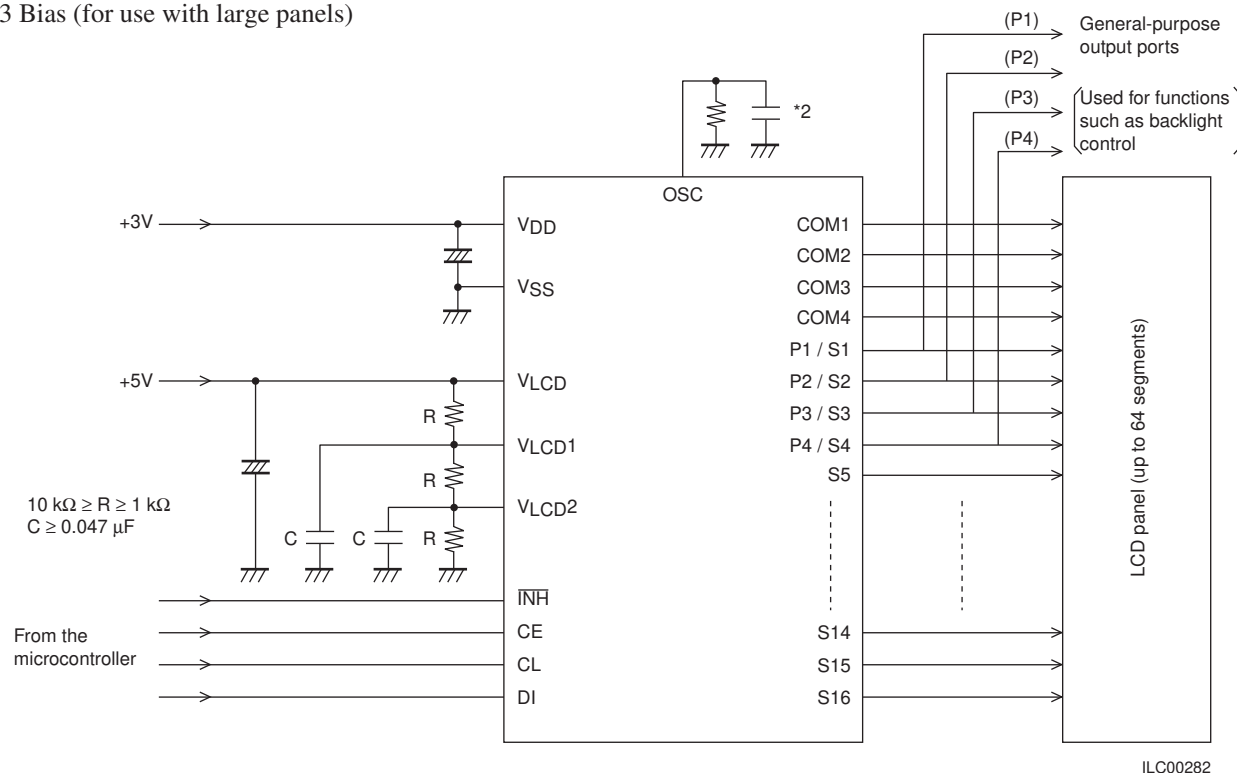

Note: *2 When a capacitor except the recommended external capacitance ($C_{OSC} = 680 \text{ pF}$) is connected the OSC pin, we recommend that applications connect the OSC pin with a capacitor in the range 220 to 2200pF.

- Specifications of any and all SANYO products described or contained herein stipulate the performance, characteristics, and functions of the described products in the independent state, and are not guarantees of the performance, characteristics, and functions of the described products as mounted in the customer's products or equipment. To verify symptoms and states that cannot be evaluated in an independent device, the customer should always evaluate and test devices mounted in the customer's products or equipment.
- SANYO Electric Co., Ltd. strives to supply high-quality high-reliability products. However, any and all semiconductor products fail with some probability. It is possible that these probabilistic failures could give rise to accidents or events that could endanger human lives, that could give rise to smoke or fire, or that could cause damage to other property. When designing equipment, adopt safety measures so that these kinds of accidents or events cannot occur. Such measures include but are not limited to protective circuits and error prevention circuits for safe design, redundant design, and structural design.
- In the event that any or all SANYO products (including technical data, services) described or contained herein are controlled under any of applicable local export control laws and regulations, such products must not be exported without obtaining the export license from the authorities concerned in accordance with the above law.
- No part of this publication may be reproduced or transmitted in any form or by any means, electronic or mechanical, including photocopying and recording, or any information storage or retrieval system, or otherwise, without the prior written permission of SANYO Electric Co., Ltd.
- Any and all information described or contained herein are subject to change without notice due to product/technology improvement, etc. When designing equipment, refer to the "Delivery Specification" for the SANYO product that you intend to use.
- Information (including circuit diagrams and circuit parameters) herein is for example only; it is not guaranteed for volume production. SANYO believes information herein is accurate and reliable, but no guarantees are made or implied regarding its use or any infringements of intellectual property rights or other rights of third parties.

This catalog provides information as of July, 2001. Specifications and information herein are subject to change without notice.