



Chipsmall Limited consists of a professional team with an average of over 10 year of expertise in the distribution of electronic components. Based in Hongkong, we have already established firm and mutual-benefit business relationships with customers from,Europe,America and south Asia,supplying obsolete and hard-to-find components to meet their specific needs.

With the principle of “Quality Parts,Customers Priority,Honest Operation,and Considerate Service”,our business mainly focus on the distribution of electronic components. Line cards we deal with include Microchip,ALPS,ROHM,Xilinx,Pulse,ON,Everlight and Freescale. Main products comprise IC,Modules,Potentiometer,IC Socket,Relay,Connector.Our parts cover such applications as commercial,industrial, and automotives areas.

We are looking forward to setting up business relationship with you and hope to provide you with the best service and solution. Let us make a better world for our industry!



Contact us

Tel: +86-755-8981 8866 Fax: +86-755-8427 6832

Email & Skype: info@chipsmall.com Web: www.chipsmall.com

Address: A1208, Overseas Decoration Building, #122 Zhenhua RD., Futian, Shenzhen, China



LC75843UGA

1/1 to 1/4-Duty General-Purpose LCD Driver



ON Semiconductor®

www.onsemi.com

Overview

The LC75843UGA is the 1/1 to 1/4 duty general-purpose microprocessor-controlled LCD driver that can be used in applications such as Automotive display. In addition to being able to drive up to 100 segments directly, the LC75843UGA can also control up to 4 general-purpose output ports. Because it has the PWM output of a maximum of 3-ch, the brightness control of the LED backlight of RGB can be done. Incorporation of an oscillation circuit helps to reduce the number of external resistors and capacitors required.

Features

- Support for static(1/1duty) or 1/2-duty 1/2-bias or 1/3-duty 1/3-bias or 1/4-duty 1/3-bias drive techniques under serial data control.
 - When 1/1-duty : Capable of driving up to 28 segments
 - When 1/2-duty : Capable of driving up to 54 segments
 - When 1/3-duty : Capable of driving up to 78 segments
 - When 1/4-duty : Capable of driving up to 100 segments
- Serial data input supports CCB* format communication with the system controller.
(Support 3.3 V and 5 V operation)
- Serial data control of the power-saving mode based backup function and the all segments forced off function.
- Serial data control of switching between the segment output port and general-purpose output port function.
(Support for up to 4 general-purpose output ports)
- Support for the PWM output function of a maximum of 3-ch.
(It can output from the general-purpose output port)
- Support for clock output function of 1-ch.
(It can output from the general-purpose output port)
- Serial data control of the frame frequency of the common and segment output waveforms.
- Serial data control of switching between the internal oscillator operating mode and external clock operating mode.
- High generality, since display data is displayed directly without the intervention of a decoder circuit.
- Built-in LCD drive bias voltage stabilization circuit.
- The $\overline{\text{INH}}$ pin allows the display to be forced to the off state.
- Incorporation of an oscillator circuit.
(Incorporation of resistor and capacitor for an oscillation)
- AEC-Q100 qualified and PPAP capable.

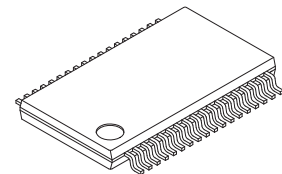

TSSOP36 5.6x9.75 / TSSOP36 (275 mil)

* Computer Control Bus (CCB) is an ON Semiconductor's original bus format and the bus addresses are controlled by ON Semiconductor.

ORDERING INFORMATION

See detailed ordering and shipping information on page 35 of this data sheet.

LC75843UGA

Specifications

Absolute Maximum Ratings at Ta = 25°C, VSS = 0 V

Parameter	Symbol	Conditions	Ratings	Unit
Maximum supply voltage	VDD max	VDD	-0.3 to +6.8	V
Input voltage	VIN	CE, CL, DI, $\overline{\text{INH}}$, OSCI	-0.3 to +6.8	V
Output voltage	VOUT	S1 to S28, COM1 to COM4, P1 to P4	-0.3 to VDD+0.3	V
Output current	IOUT1	S1 to S28	300	μA
	IOUT2	COM1 to COM4	3	mA
	IOUT3	P1 to P4	5	
Allowable power dissipation	Pd max	Ta = 105°C	50	mW
Operating temperature	Topr		-40 to +105	°C
Storage temperature	Tstg		-55 to +125	°C

Stresses exceeding those listed in the Maximum Ratings table may damage the device. If any of these limits are exceeded, device functionality should not be assumed, damage may occur and reliability may be affected.

Allowable Operating Ranges at Ta = -40 to +105°C, VSS = 0 V

Parameter	Symbol	Conditions	Ratings			Unit
			min	typ	max	
Supply voltage	VDD	VDD	4.5		6.3	V
Input high level voltage	VIH1	CE, CL, DI, $\overline{\text{INH}}$	0.4VDD		6.3	V
	VIH2	OSCI	0.4VDD		6.3	
Input low level voltage	VIL1	CE, CL, DI, $\overline{\text{INH}}$	0		0.2VDD	V
	VIL2	OSCI	0		0.2VDD	
External clock operating frequency	fCK	OSCI, External clock operating mode [Figure 3]	10	300	600	kHz
External clock duty cycle	DCK	OSCI, External clock operating mode [Figure 3]	30	50	70	%
Data setup time	tds	CL, DI [Figure 1], [Figure 2]	160			ns
Data hold time	tdh	CL, DI [Figure 1], [Figure 2]	160			ns
CE wait time	tcp	CE, CL [Figure 1], [Figure 2]	160			ns
CE setup time	tcs	CE, CL [Figure 1], [Figure 2]	160			ns
CE hold time	tch	CE, CL [Figure 1], [Figure 2]	160			ns
High level clock pulse width	tφH	CL [Figure 1], [Figure 2]	160			ns
Low level clock pulse width	tφL	CL [Figure 1], [Figure 2]	160			ns
Rise time	tr	CE, CL, DI [Figure 1], [Figure 2]		160		ns
Fall time	tf	CE, CL, DI [Figure 1], [Figure 2]		160		ns
$\overline{\text{INH}}$ switching time	tc	$\overline{\text{INH}}$, CE [Figure 4], [Figure 5] [Figure 6], [Figure 7]	10			μs

Functional operation above the stresses listed in the Recommended Operating Ranges is not implied. Extended exposure to stresses beyond the Recommended Operating Ranges limits may affect device reliability.

LC75843UGA

Electrical Characteristics for the Allowable Operating Ranges

Parameter	Symbol	Pin	Conditions	Ratings			Unit
				min	typ	max	
Hysteresis	V_H	CE, CL, DI, \overline{INH}			$0.03V_{DD}$		V
Input high level current	I_{IH1}	CE, CL, DI, \overline{INH}	$V_I = 6.3\text{ V}$			5.0	μA
	I_{IH2}	OSCI	$V_I = 6.3\text{ V}$			5.0	
Input low level current	I_{IL1}	CE, CL, DI, \overline{INH}	$V_I = 0\text{ V}$	-5.0			μA
	I_{IL2}	OSCI	$V_I = 0\text{ V}$	-5.0			
Output high level voltage	V_{OH1}	S1 to S28	$I_O = -20\ \mu\text{A}$	V_{DD} -0.9			V
	V_{OH2}	COM1 to COM4	$I_O = -100\ \mu\text{A}$	V_{DD} -0.9			
	V_{OH3}	P1 to P4	$I_O = -1\text{ mA}$	V_{DD} -0.9			
Output low level voltage	V_{OL1}	S1 to S28	$I_O = 20\ \mu\text{A}$			0.9	V
	V_{OL2}	COM1 to COM4	$I_O = 100\ \mu\text{A}$			0.9	
	V_{OL3}	P1 to P4	$I_O = 1\text{ mA}$			0.9	
Output middle level voltage	V_{MID1}	S1 to S25, S28	1/3 bias $I_O = \pm 20\ \mu\text{A}$	$2/3V_{DD}$ -0.9		$2/3V_{DD}$ +0.9	V
	V_{MID2}	S1 to S25, S28	1/3 bias $I_O = \pm 20\ \mu\text{A}$	$1/3V_{DD}$ -0.9		$1/3V_{DD}$ +0.9	
	V_{MID3}	COM1 to COM4	1/3 bias $I_O = \pm 100\ \mu\text{A}$	$2/3V_{DD}$ -0.9		$2/3V_{DD}$ +0.9	
	V_{MID4}	COM1 to COM4	1/3 bias $I_O = \pm 100\ \mu\text{A}$	$1/3V_{DD}$ -0.9		$1/3V_{DD}$ +0.9	
	V_{MID5}	COM1, COM2	1/2 bias $I_O = \pm 100\ \mu\text{A}$	$1/2V_{DD}$ -0.9		$1/2V_{DD}$ +0.9	
Oscillator frequency	fosc	Internal oscillator circuit	Internal oscillator operating mode	240	300	360	kHz
Current drain	I_{DD1}	V_{DD}	Power-saving mode			100	μA
	I_{DD2}	V_{DD}	$V_{DD} = 6.3\text{ V}$ Output open Internal oscillator operating mode		750	1500	
	I_{DD3}	V_{DD}	$V_{DD} = 6.3\text{ V}$ Output open External clock operating mode $f_{CK} = 300\text{ kHz}$ $V_{IH2} = 0.5V_{DD}$ $V_{IL2} = 0.1V_{DD}$		750	1500	

*We have a case to change these electrical characteristics without a notice for improvement.

Product parametric performance is indicated in the Electrical Characteristics for the listed test conditions, unless otherwise noted. Product performance may not be indicated by the Electrical Characteristics if operated under different conditions.

LC75843UGA

1. When CL is stopped at the low level

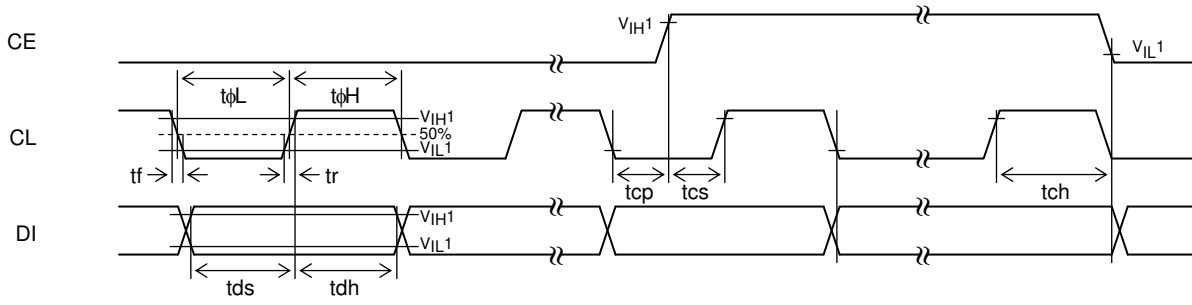

[Figure 1]

2. When CL is stopped at the high level

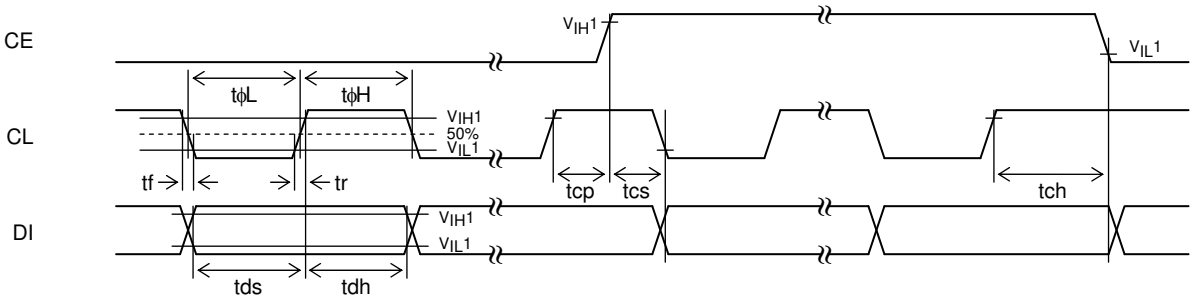

[Figure 2]

3. OSCI pin clock timing in external clock operating mode

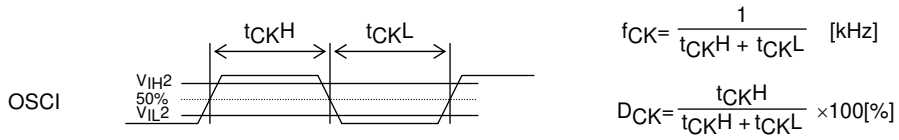

[Figure 3]

LC75843UGA

Package Dimensions

unit : mm

TSSOP36 5.6x9.75 / TSSOP36 (275 mil)

CASE 948BC

ISSUE A

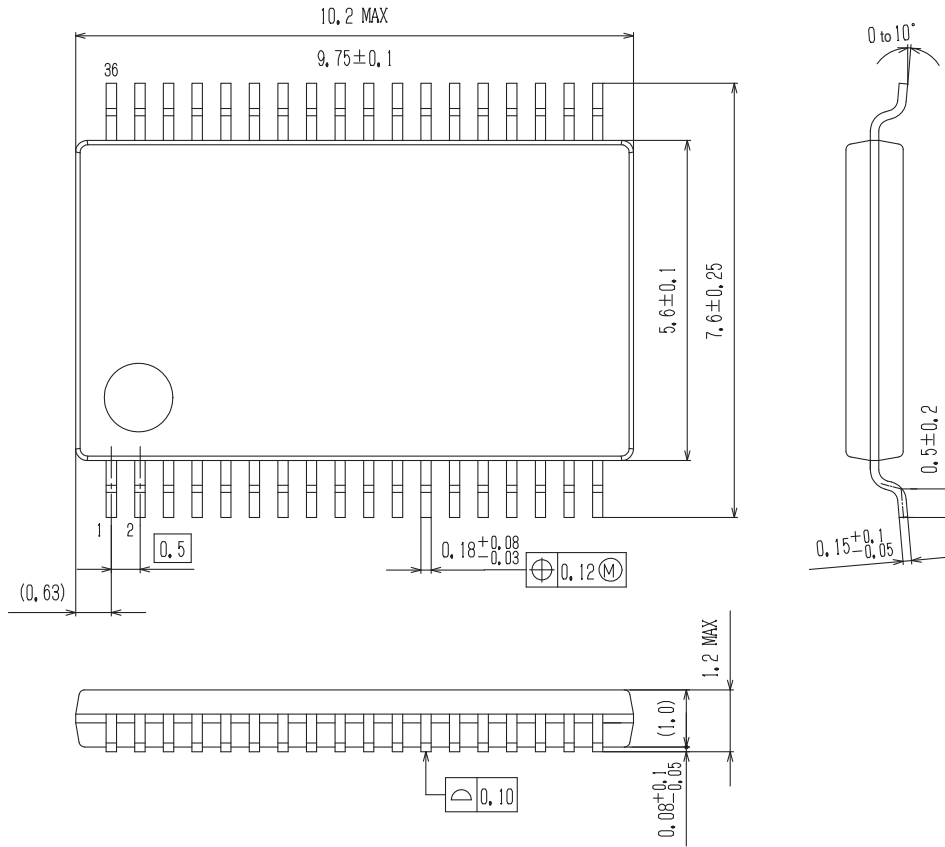

SOLDERING FOOTPRINT*

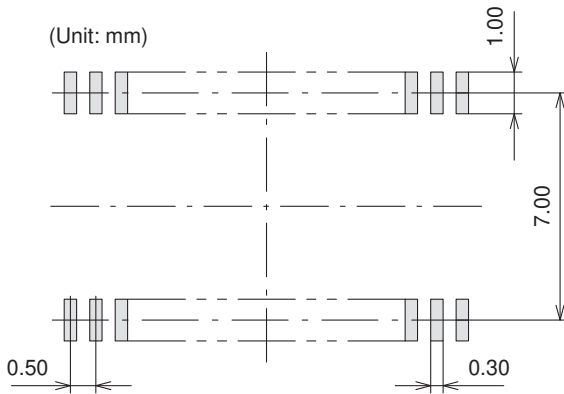

GENERIC MARKING DIAGRAM*

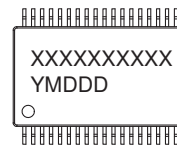

XXXXXX = Specific Device Code
Y = Year
M = Month
DDD = Additional Traceability Data

*This information is generic. Please refer to device data sheet for actual part marking. Pb-Free indicator, "G" or microdot "■", may or may not be present.

NOTE: The measurements are not to guarantee but for reference only.

*For additional information on our Pb-Free strategy and soldering details, please download the ON Semiconductor Soldering and Mounting Techniques Reference Manual, SOLDERRM/D.

LC75843UGA

Pin Assignment

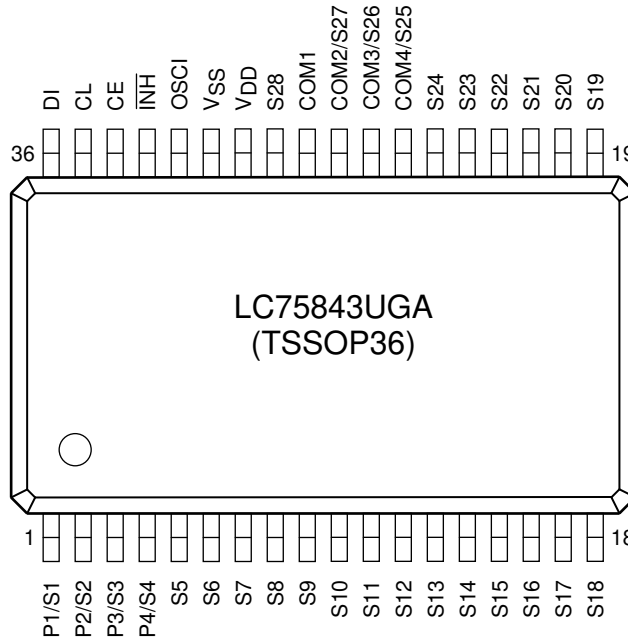

Top view

Block Diagram

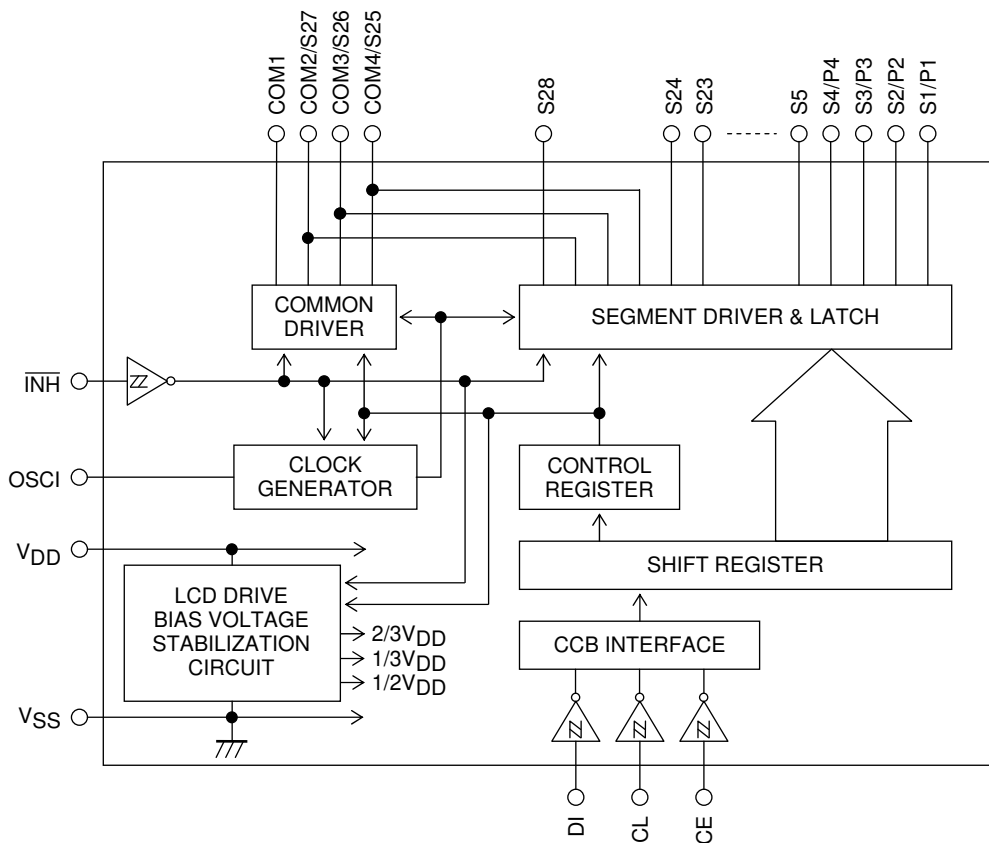

LC75843UGA

Pin Functions

Symbol	Pin No.	Function	Active	I/O	Handling when unused
S1/P1 to S4/P4 S5 to S24 S28	1 to 4 5 to 24 29	Segment outputs for displaying the display data transferred by serial data input. The S1/P1 to S4/P4 pins can be used as general-purpose output ports under serial data control.	-	O	OPEN
COM1 COM2/S27 COM3/S26 COM4/S25	28 27 26 25	Common driver outputs The frame frequency is f_0 [Hz]. The COM2/S27 to COM4/S25 pin can be used as a segment output by control data.	-	O	OPEN
OSCI	32	This is input pin for the external clock. Input the clock at external clock operating mode. Furthermore, connect to GND at internal oscillator operating mode.	-	I	GND
CE CL DI	34 35 36	Serial data transfer inputs. Must be connected to the controller. CE : Chip enable CL : Synchronization clock DI : Transfer data	H  -	I I I	GND
$\overline{\text{INH}}$	33	Display off control input • $\overline{\text{INH}}=\text{low}(V_{\text{SS}})$...Display forced off S1/P1 to S4/P4= $\text{low}(V_{\text{SS}})$ (These pins are forcibly set to the general-purpose output port function and held at the V_{SS} level.) S5 to S24, S28= $\text{low}(V_{\text{SS}})$ COM1= $\text{low}(V_{\text{SS}})$ COM2/S27 to COM4/S25= $\text{low}(V_{\text{SS}})$ Stops the internal oscillator. Inhibits external clock input. • $\overline{\text{INH}}=\text{high}(V_{\text{DD}})$...Display on Enables the internal oscillator circuit. (Internal oscillator operating mode) Enables external clock input. (External clock operating mode) However, serial data transfer is possible when the display is forced off.	L	I	GND
V_{DD}	30	Power supply pin. A power voltage of 4.5 to 6.3 V must be applied to this pin.	-	-	-
V_{SS}	31	Ground pin. Must be connected to ground.	-	-	-

LC75843UGA

Serial Data Input

1. 1/4 duty

(1) When CL is stopped at the low level

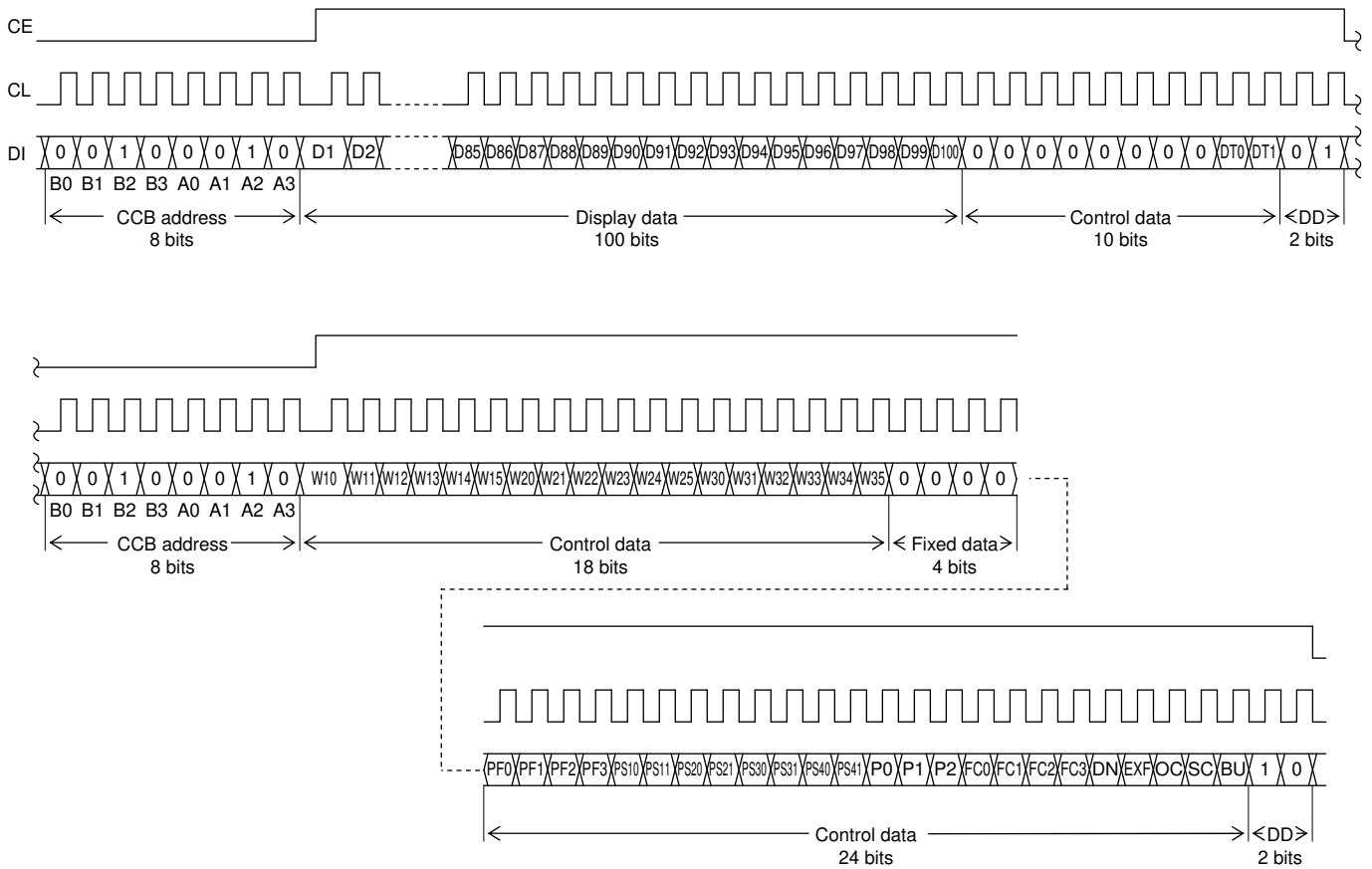

Note: DD is the direction data

- CCB address “44H”
- D1 to D100 Display data
- DT0, DT1 1/1-duty to 1/4-duty drive switching control data
- W 10 to W15, W20 to W25, W30 to W35 ... PWM data of the PWM output
- PF0 to PF3 PWM output waveform frame frequency setting control data
- PS10, PS11 to PS40, PS41 General-purpose output port (P1 to P4) function setting control data
- P0 to P2 Segment output port/general-purpose output port switching control data
- FC0 to FC3 Common/segment output waveform frame frequency setting control data
- DN S28 pin state setting control data
- EXF External clock operating frequency setting control data
- OC Internal oscillator operating mode/external clock operating mode switching control data
- SC Segment on/off control data
- BU Normal mode/power-saving mode control data

LC75843UGA

(2) When CL is stopped at the high level

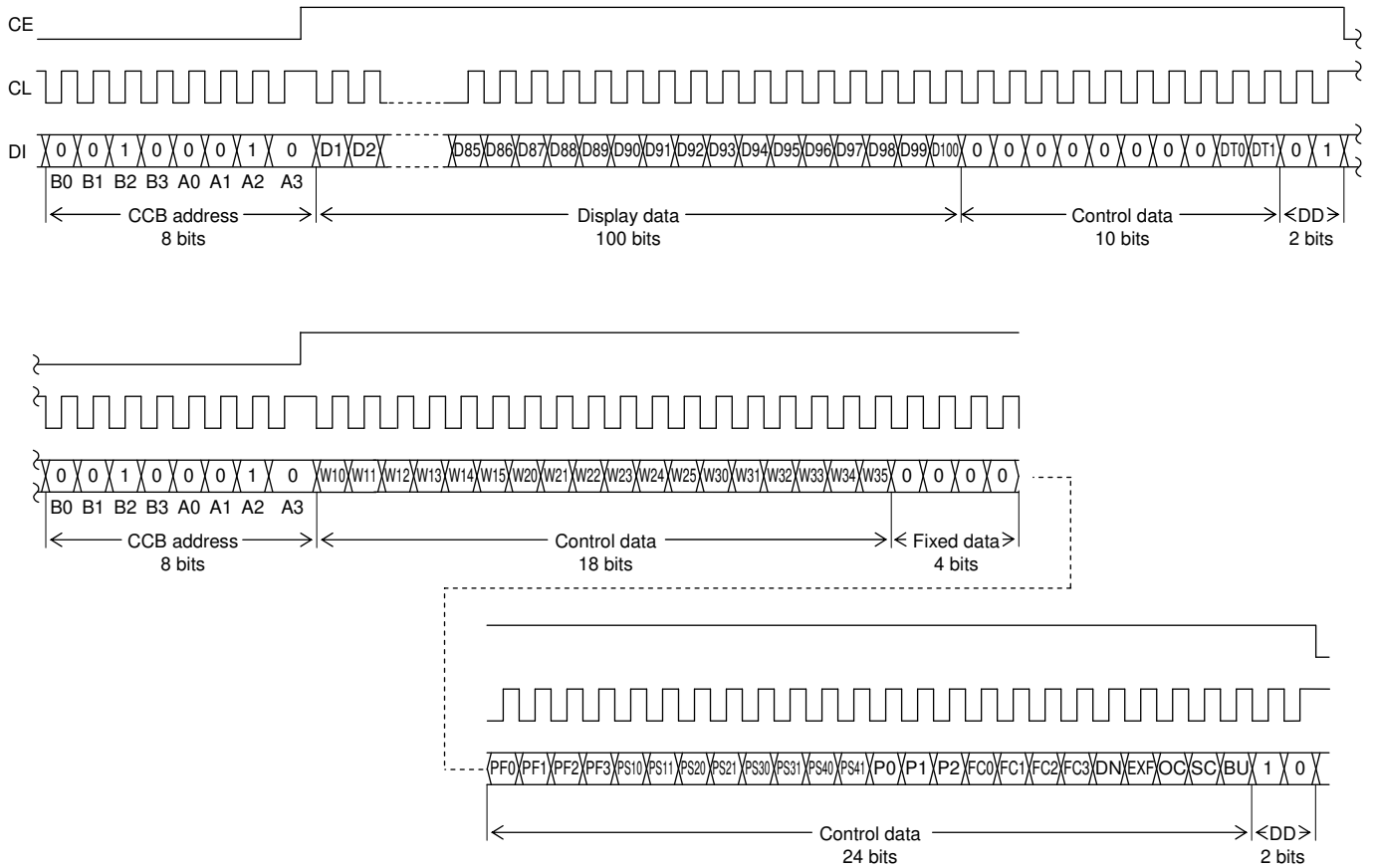

Note: DD is the direction data

- CCB address “44H”
- D1 to D100 Display data
- DT0, DT1 1/1-duty to 1/4-duty drive switching control data
- W 10 to W15, W20 to W25, W30 to W35 ... PWM data of the PWM output
- PF0 to PF3 PWM output waveform frame frequency setting control data
- PS10, PS11 to PS40, PS41 General-purpose output port (P1 to P4) function setting control data
- P0 to P2 Segment output port/general-purpose output port switching control data
- FC0 to FC3 Common/segment output waveform frame frequency setting control data
- DN S28 pin state setting control data
- EXF External clock operating frequency setting control data
- OC Internal oscillator operating mode/external clock operating mode switching control data
- SC Segment on/off control data
- BU Normal mode/power-saving mode control data

LC75843UGA

2. 1/3 duty

(1) When CL is stopped at the low level

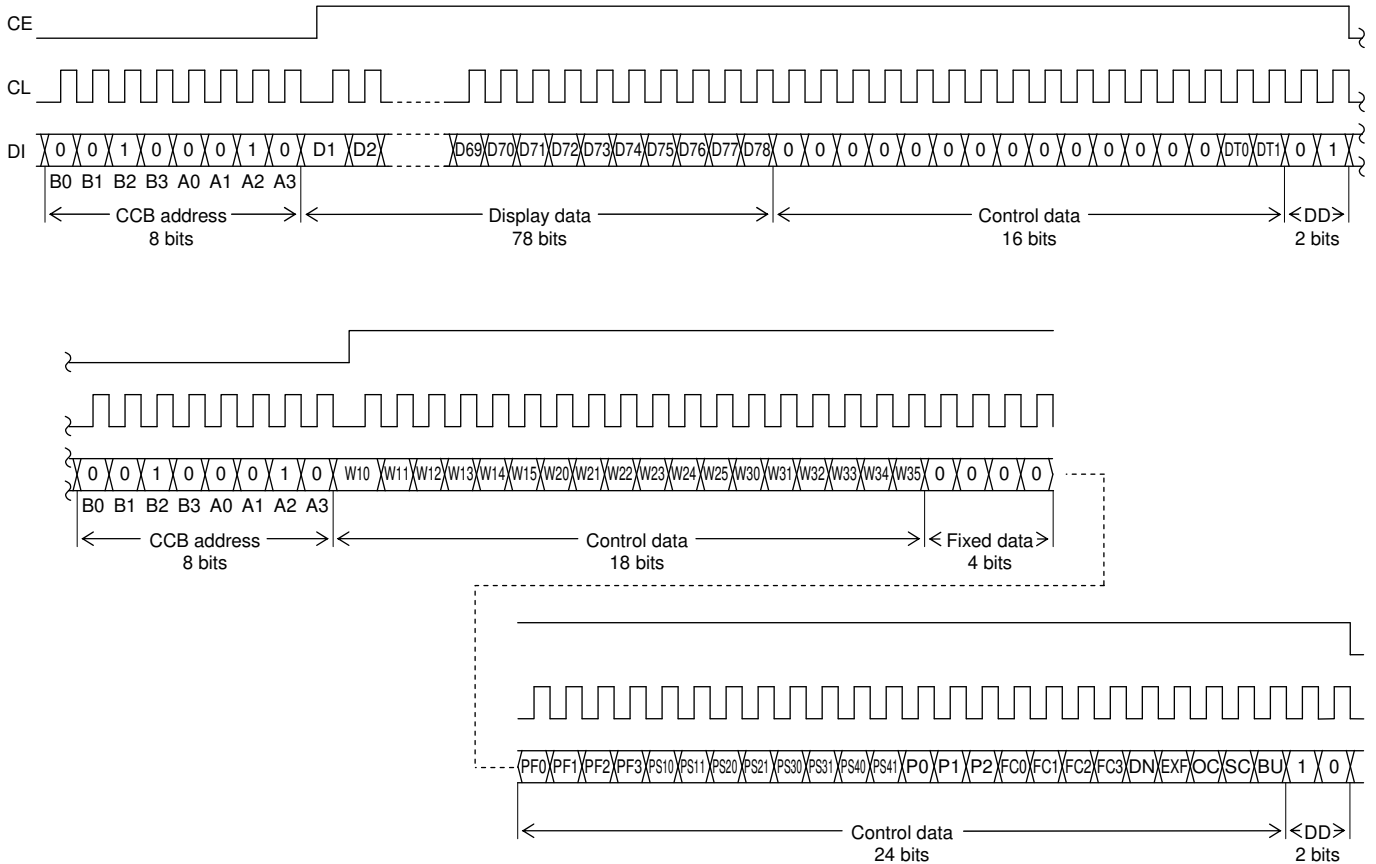

Note: DD is the direction data

- CCB address “44H”
- D1 to D78 Display data
- DT0, DT1 1/1-duty to 1/4-duty drive switching control data
- W 10 to W15, W20 to W25, W30 to W35 ... PWM data of the PWM output
- PF0 to PF3 PWM output waveform frame frequency setting control data
- PS10, PS11 to PS40, PS41 General-purpose output port (P1 to P4) function setting control data
- P0 to P2 Segment output port/general-purpose output port switching control data
- FC0 to FC3 Common/segment output waveform frame frequency setting control data
- DN S28 pin state setting control data
- EXF External clock operating frequency setting control data
- OC Internal oscillator operating mode/external clock operating mode switching control data
- SC Segment on/off control data
- BU Normal mode/power-saving mode control data

LC75843UGA

(2) When CL is stopped at the high level

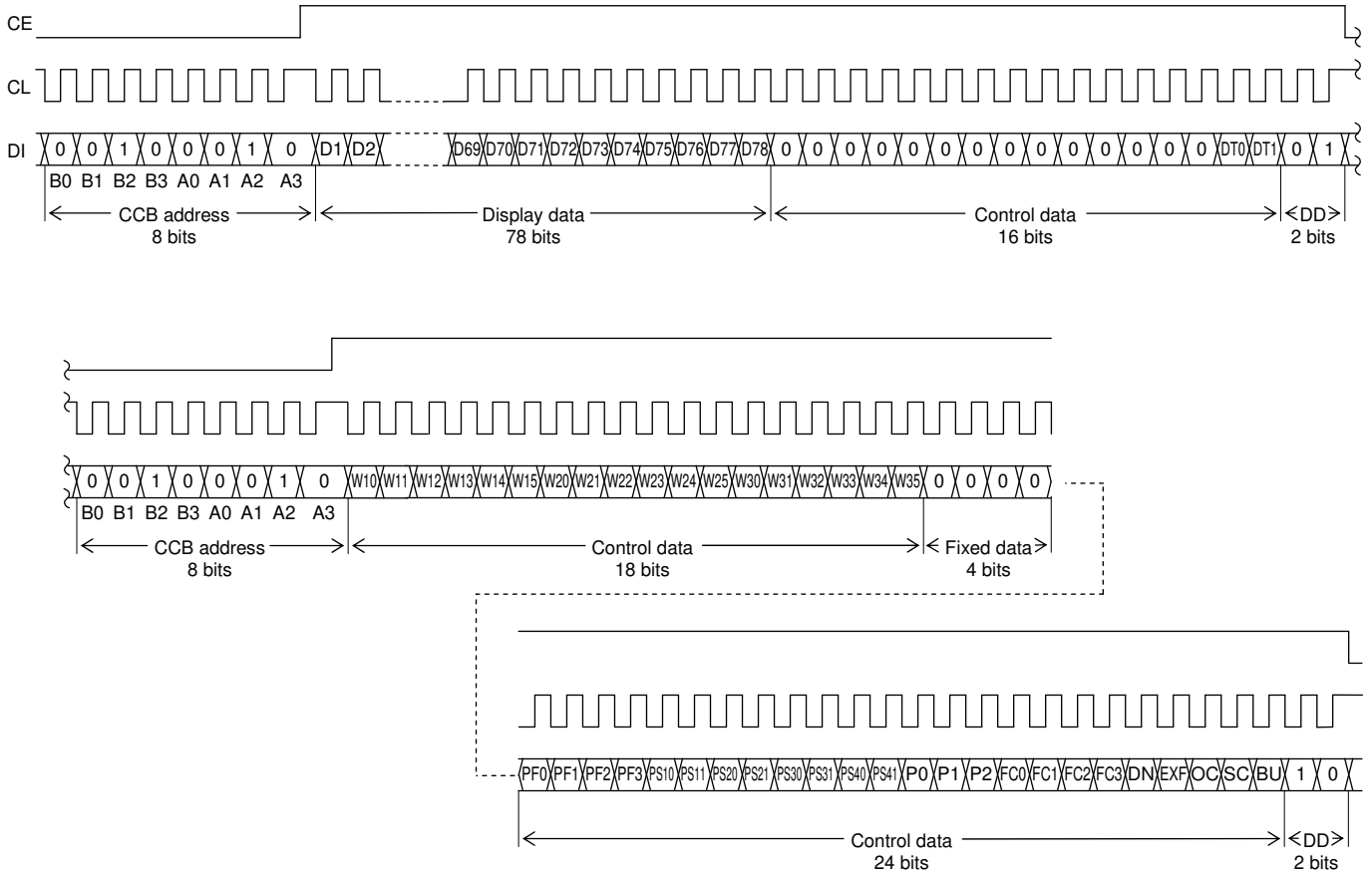

Note: DD is the direction data

- CCB address “44H”
- D1 to D78 Display data
- DT0, DT1 1/1-duty to 1/4-duty drive switching control data
- W 10 to W15, W20 to W25, W30 to W35 ... PWM data of the PWM output
- PF0 to PF3 PWM output waveform frame frequency setting control data
- PS10, PS11 to PS40, PS41 General-purpose output port (P1 to P4) function setting control data
- P0 to P2 Segment output port/general-purpose output port switching control data
- FC0 to FC3 Common/segment output waveform frame frequency setting control data
- DN S28 pin state setting control data
- EXF External clock operating frequency setting control data
- OC Internal oscillator operating mode/external clock operating mode switching control data
- SC Segment on/off control data
- BU Normal mode/power-saving mode control data

LC75843UGA

3. 1/2 duty

(1) When CL is stopped at the low level

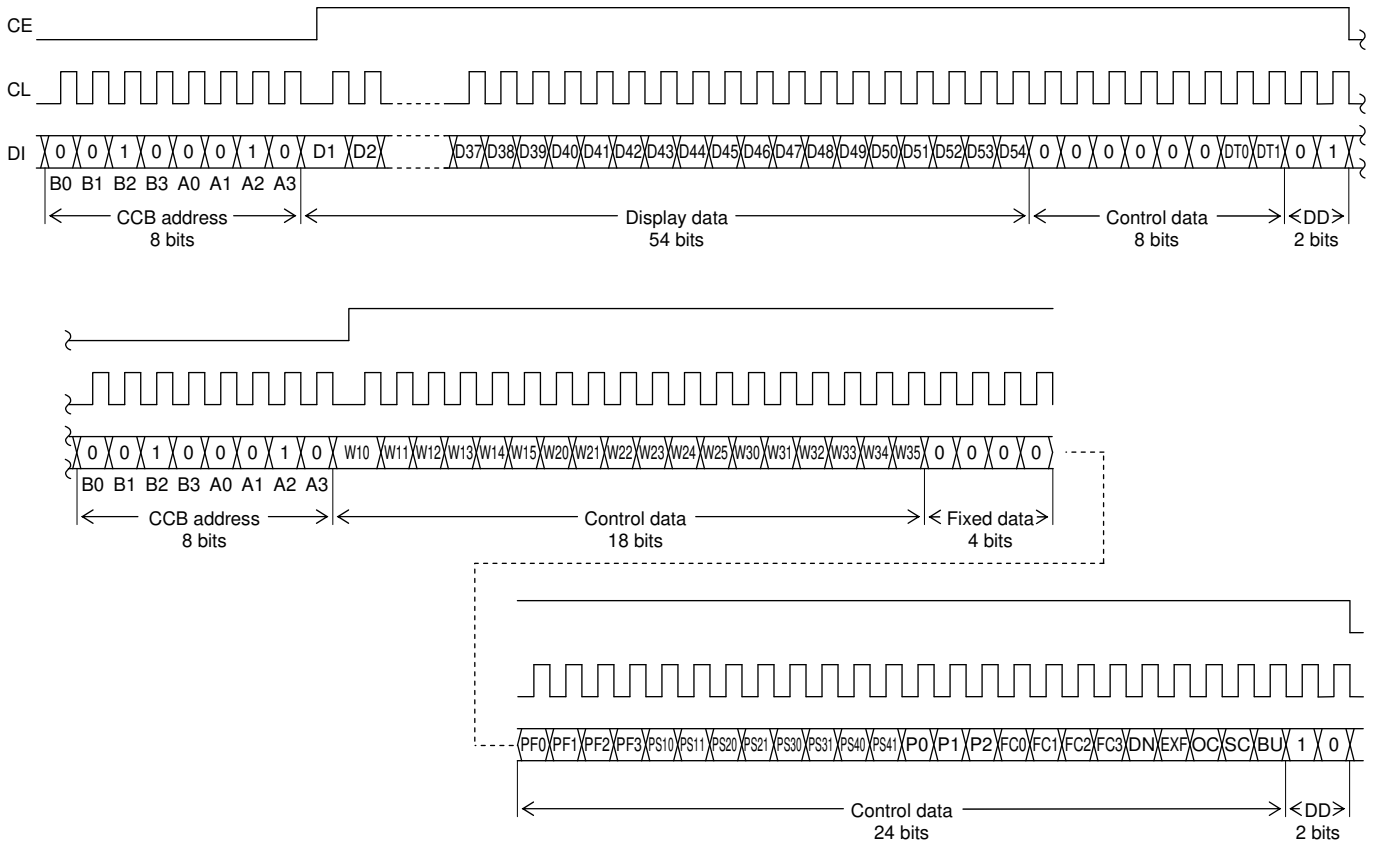

Note: DD is the direction data

- CCB address “44H”
- D1 to D54 Display data
- DT0, DT1 1/1-duty to 1/4-duty drive switching control data
- W 10 to W15, W20 to W25, W30 to W35 ... PWM data of the PWM output
- PF0 to PF3 PWM output waveform frame frequency setting control data
- PS10, PS11 to PS40, PS41 General-purpose output port (P1 to P4) function setting control data
- P0 to P2 Segment output port/general-purpose output port switching control data
- FC0 to FC3 Common/segment output waveform frame frequency setting control data
- DN S28 pin state setting control data
- EXF External clock operating frequency setting control data
- OC Internal oscillator operating mode/external clock operating mode switching control data
- SC Segment on/off control data
- BU Normal mode/power-saving mode control data

LC75843UGA

(2) When CL is stopped at the high level

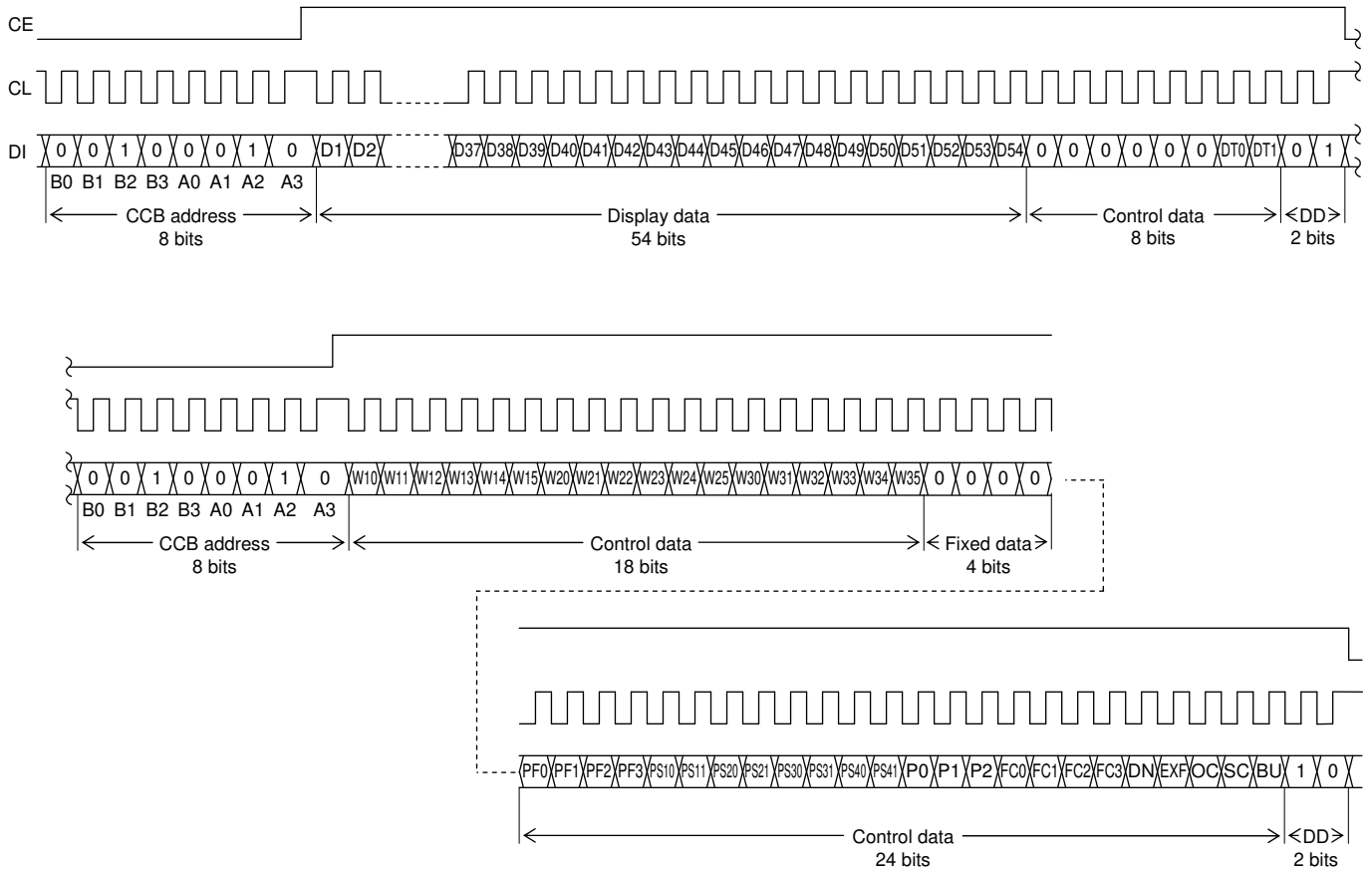

Note: DD is the direction data

- CCB address “44H”
- D1 to D54 Display data
- DT0, DT1 1/1-duty to 1/4-duty drive switching control data
- W 10 to W15, W20 to W25, W30 to W35 ... PWM data of the PWM output
- PF0 to PF3 PWM output waveform frame frequency setting control data
- PS10, PS11 to PS40, PS41 General-purpose output port (P1 to P4) function setting control data
- P0 to P2 Segment output port/general-purpose output port switching control data
- FC0 to FC3 Common/segment output waveform frame frequency setting control data
- DN S28 pin state setting control data
- EXF External clock operating frequency setting control data
- OC Internal oscillator operating mode/external clock operating mode switching control data
- SC Segment on/off control data
- BU Normal mode/power-saving mode control data

LC75843UGA

4. 1/1 duty

(1) When CL is stopped at the low level

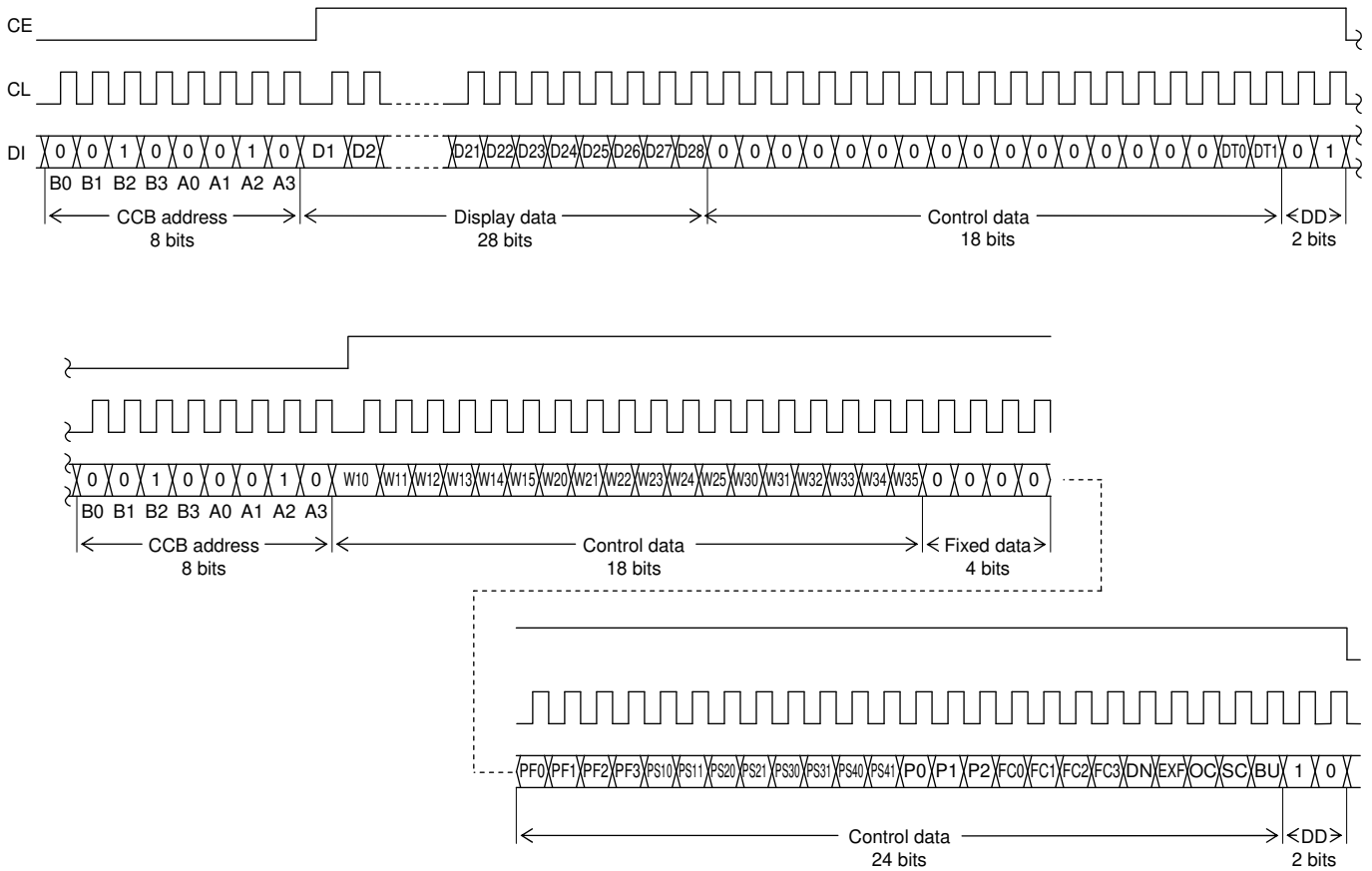

Note: DD is the direction data

- CCB address “44H”
- D1 to D28 Display data
- DT0, DT1 1/1-duty to 1/4-duty drive switching control data
- W 10 to W15, W20 to W25, W30 to W35 ... PWM data of the PWM output
- PF0 to PF3 PWM output waveform frame frequency setting control data
- PS10, PS11 to PS40, PS41 General-purpose output port (P1 to P4) function setting control data
- P0 to P2 Segment output port/general-purpose output port switching control data
- FC0 to FC3 Common/segment output waveform frame frequency setting control data
- DN S28 pin state setting control data
- EXF External clock operating frequency setting control data
- OC Internal oscillator operating mode/external clock operating mode switching control data
- SC Segment on/off control data
- BU Normal mode/power-saving mode control data

LC75843UGA

(2) When CL is stopped at the high level

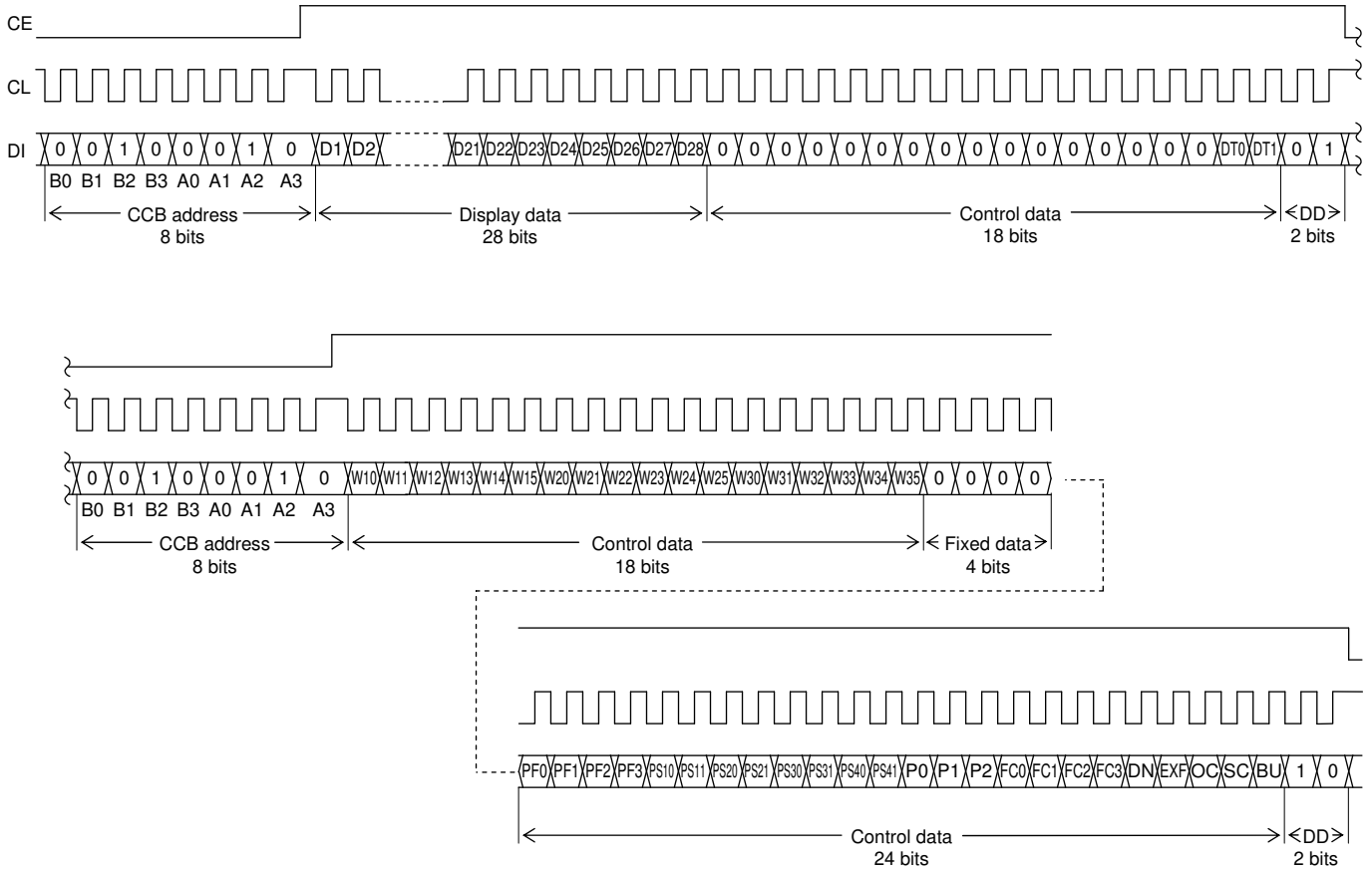

Note: DD is the direction data

- CCB address “44H”
- D1 to D28 Display data
- DT0, DT1 1/1-duty to 1/4-duty drive switching control data
- W 10 to W15, W20 to W25, W30 to W35 ... PWM data of the PWM output
- PF0 to PF3 PWM output waveform frame frequency setting control data
- PS10, PS11 to PS40, PS41 General-purpose output port (P1 to P4) function setting control data
- P0 to P2 Segment output port/general-purpose output port switching control data
- FC0 to FC3 Common/segment output waveform frame frequency setting control data
- DN S28 pin state setting control data
- EXF External clock operating frequency setting control data
- OC Internal oscillator operating mode/external clock operating mode switching control data
- SC Segment on/off control data
- BU Normal mode/power-saving mode control data

Serial Data Transfer Example

1. 1/4 duty

All 160 bits of serial data must be sent.

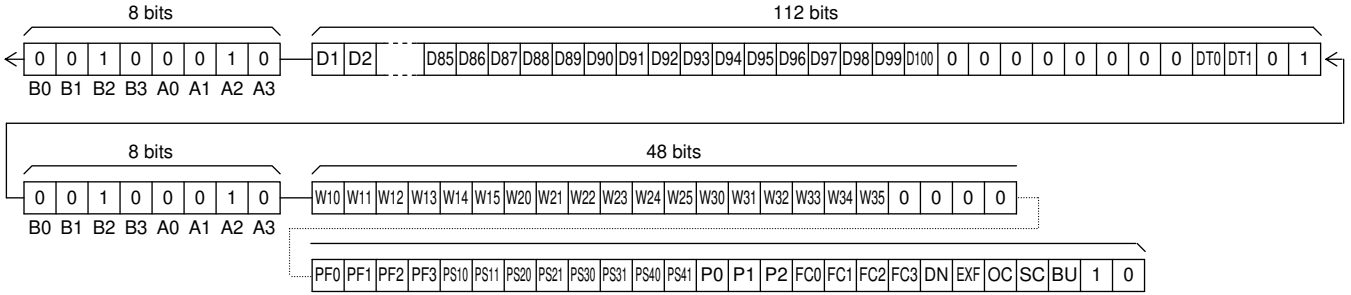

2. 1/3 duty

All 144 bits of serial data must be sent.

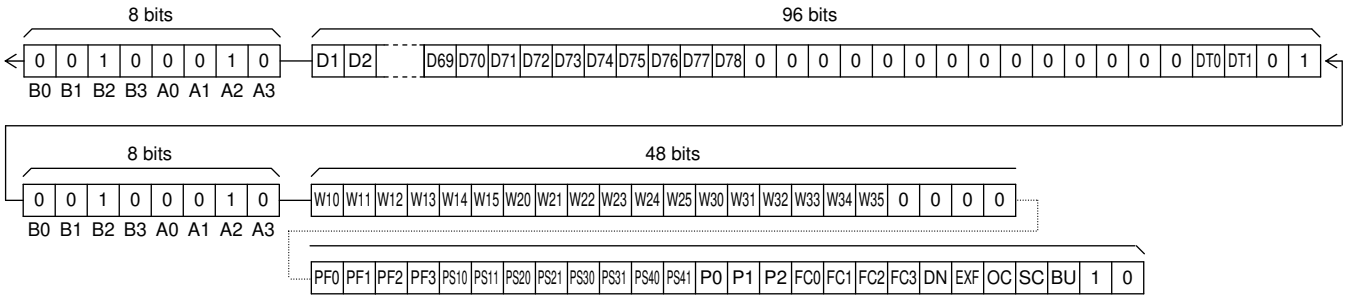

3. 1/2 duty

All 112 bits of serial data must be sent.

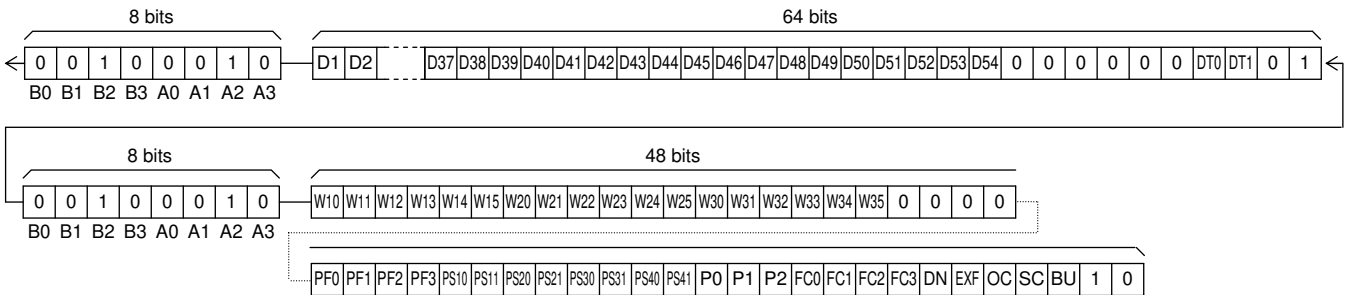

4. 1/1 duty

All 96 bits of serial data must be sent.

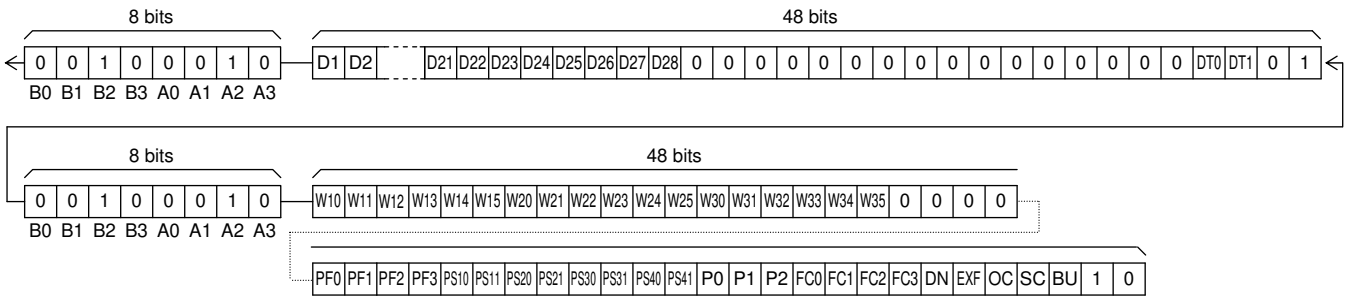

Control Data Functions

(1) DT0, DT1 . . . LCD drive scheme (1/1-duty to 1/4-duty drive) switching control data.

These control data bits select 1/4-duty 1/3 bias drive, 1/3-duty 1/3 bias drive, 1/2-duty 1/2 bias drive, or 1/1-duty drive.

DT0	DT1	Drive scheme	Pin state		
			COM2/S27	COM3/S26	COM4/S25
0	0	1/4-duty 1/3-bias drive	COM2	COM3	COM4
1	0	1/3-duty 1/3-bias drive	COM2	COM3	S25
0	1	1/2-duty 1/2-bias drive	COM2	S26	S25
1	1	static (1/1-duty drive)	S27	S26	S25

Note: COM2 to COM4: Common output , S27 to S25: Segment output

(2) PF0 to PF3 . . . PWM output waveform frame frequency setting control data

These control data bits set the frame frequency of the PWM output waveforms. However, when the PWM output function isn't used, these control data bits become invalid. In addition, when the external clock operating frequency is set the $f_{CK2} = 38[\text{kHz}]$ typ (EXF = "1") in external clock operating mode (OC = "1"), these control data bits become invalid.

Control data				PWM output waveform frame frequency fp[Hz]	
PF0	PF1	PF2	PF3	Internal oscillator operating mode	External clock operating mode
				(The control data OC is 0, $f_{osc}=300[\text{kHz}]$ typ)	(The control data OC is 1, and EXF is 0, $f_{CK1}=300[\text{kHz}]$ typ)
0	0	0	0	$f_{osc}/1536$	$f_{CK1}/1536$
1	0	0	0	$f_{osc}/1408$	$f_{CK1}/1408$
0	1	0	0	$f_{osc}/1280$	$f_{CK1}/1280$
1	1	0	0	$f_{osc}/1152$	$f_{CK1}/1152$
0	0	1	0	$f_{osc}/1024$	$f_{CK1}/1024$
1	0	1	0	$f_{osc}/896$	$f_{CK1}/896$
0	1	1	0	$f_{osc}/768$	$f_{CK1}/768$
1	1	1	0	$f_{osc}/640$	$f_{CK1}/640$
0	0	0	1	$f_{osc}/512$	$f_{CK1}/512$
1	0	0	1	$f_{osc}/384$	$f_{CK1}/384$
0	1	0	1	$f_{osc}/256$	$f_{CK1}/256$

Note: When is setting (PF0, PF1, PF2, PF3)=(1, 1, 0, 1) and (X, X, 1, 1), the frame frequency is same as frame frequency at the time of the (PF0, PF1, PF2, PF3)=(1, 0, 1, 0) setting ($f_{osc}/896$, $f_{CK1}/896$).

X : don't care

LC75843UGA

(3) PS10, PS11 to PS40, PS41 . . . General-purpose output port (P1 to P4) function setting control data

These control data bits set the general-purpose output function (High or low level output), clock output function or PWM output function of the P1 output pin, and the general-purpose output function (High or low level output) or PWM output function of the P2 to P4 output pins.

However, be careful of being unable to set a PWM output function when the external clock operating frequency is set the $f_{CK2} = 38[\text{kHz}]$ typ (EXF = "1") in external clock operating mode (OC = "1").

PS10	PS11	General-purpose output port (P1) function
0	0	General-purpose output function (High or low level output)
1	0	Clock output function (clock frequency : $f_{osc}/2$, $f_{CK}/2$)
0	1	Clock output function (clock frequency : $f_{osc}/8$, $f_{CK}/8$)
1	1	PWM output function (ch1) (Support for PWM data W10 to W15)

PS20	PS21	General-purpose output port (P2) function
0	0	General-purpose output function (High or low level output)
1	0	PWM output function (ch1) (Support for PWM data W10 to W15)
0	1	PWM output function (ch2) (Support for PWM data W20 to W25)
1	1	PWM output function (ch3) (Support for PWM data W30 to W35)

PS30	PS31	General-purpose output port (P3) function
0	0	General-purpose output function (High or low level output)
1	0	PWM output function (ch1) (Support for PWM data W10 to W15)
0	1	PWM output function (ch2) (Support for PWM data W20 to W25)
1	1	PWM output function (ch3) (Support for PWM data W30 to W35)

PS40	PS41	General-purpose output port (P4) function
0	0	General-purpose output function (High or low level output)
1	0	PWM output function (ch1) (Support for PWM data W10 to W15)
0	1	PWM output function (ch2) (Support for PWM data W20 to W25)
1	1	PWM output function (ch3) (Support for PWM data W30 to W35)

(4) P0 to P2 . . . Segment output port/general-purpose output port switching control data.

These control data bits switch the segment output port/general-purpose output port functions of the S1/P1 to S4/P4 output pins.

Control data			Output pin state			
P0	P1	P2	S1/P1	S2/P2	S3/P3	S4/P4
0	0	0	S1	S2	S3	S4
0	0	1	P1	S2	S3	S4
0	1	0	P1	P2	S3	S4
0	1	1	P1	P2	P3	S4
1	0	0	P1	P2	P3	P4

Note: $S_n(n=1$ to 4): Segment output ports
 $P_n(n=1$ to 4): General-purpose output ports

Note: When are setting (P0, P1, P2)=(1, 0, 1), (1, 1, 0), and (1, 1, 1), the all P1/S1 to P4/S4 output pins selects the segment output port.

The table below lists the correspondence between the display data and the output pins when these pins are selected to be general-purpose output ports.

Output pin	Correspondence display data			
	1/4 duty	1/3 duty	1/2 duty	1/1 duty
S1/P1	D1	D1	D1	D1
S2/P2	D5	D4	D3	D2
S3/P3	D9	D7	D5	D3
S4/P4	D13	D10	D7	D4

For example, if the circuit is operated in 1/4 duty and the S4/P4 output pin is selected to be a general-purpose output port, the S4/P4 output pin will output a high level when the display data D13 is 1, and will output a low level when D13 is 0.

LC75843UGA

(5) FC0 to FC3 . . . Common/segment output waveform frame frequency control data

These control data bits set the frame frequency of the common and segment output waveforms.

Control data				Frame frequency f_0 [Hz]		
FC0	FC1	FC2	FC3	Internal oscillator operating mode (The control data OC is 0, $f_{osc}=300$ [kHz]typ)	External clock operating mode (The control data OC is 1, and EXF is 0, $f_{CK1}=300$ [kHz]typ)	External clock operating mode (The control data OC is 1, and EXF is 1, $f_{CK2}=38$ [kHz]typ)
0	0	0	0	$f_{osc}/6144$	$f_{CK1}/6144$	$f_{CK2}/768$
0	0	0	1	$f_{osc}/5376$	$f_{CK1}/5376$	$f_{CK2}/672$
0	0	1	0	$f_{osc}/4608$	$f_{CK1}/4608$	$f_{CK2}/576$
0	0	1	1	$f_{osc}/3840$	$f_{CK1}/3840$	$f_{CK2}/480$
0	1	0	0	$f_{osc}/3456$	$f_{CK1}/3456$	$f_{CK2}/432$
0	1	0	1	$f_{osc}/3072$	$f_{CK1}/3072$	$f_{CK2}/384$
0	1	1	0	$f_{osc}/2688$	$f_{CK1}/2688$	$f_{CK2}/336$
0	1	1	1	$f_{osc}/2304$	$f_{CK1}/2304$	$f_{CK2}/288$
1	0	0	0	$f_{osc}/2112$	$f_{CK1}/2112$	$f_{CK2}/264$
1	0	0	1	$f_{osc}/1920$	$f_{CK1}/1920$	$f_{CK2}/240$
1	0	1	0	$f_{osc}/1728$	$f_{CK1}/1728$	$f_{CK2}/216$
1	0	1	1	$f_{osc}/1536$	$f_{CK1}/1536$	$f_{CK2}/192$
1	1	0	0	$f_{osc}/1344$	$f_{CK1}/1344$	$f_{CK2}/168$
1	1	0	1	$f_{osc}/1152$	$f_{CK1}/1152$	$f_{CK2}/144$
1	1	1	0	$f_{osc}/960$	$f_{CK1}/960$	$f_{CK2}/120$
1	1	1	1	$f_{osc}/768$	$f_{CK1}/768$	$f_{CK2}/96$

(6) DN . . . S28 pin state setting control data

This control data bit sets state of the S28 pin.

DN	Number of display segments				Pin state
	1/4 duty	1/3 duty	1/2 duty	1/1 duty	S28
0	Up to 96 segments	Up to 75 segments	Up to 52 segments	Up to 27 segments	"L" (V_{SS})
1	Up to 100 segments	Up to 78 segments	Up to 54 segments	Up to 28 segments	S28

(7) EXF . . . External clock operating frequency setting control data

This control data sets the operating frequency of the external clock which input into the OSC1 pin, when the external clock operating mode (OC = "1") is set. However, this control data is effective only when external clock operating mode (OC = "1") is set.

EXF	External clock operating frequency f_{CK} [KHz]
0	$f_{CK1}=300$ [kHz]typ
1	$f_{CK2}=38$ [kHz]typ

(8) OC . . . Internal oscillator operating mode/external clock operating mode switching control data.

This control data bit selects either the internal oscillator operating mode or external clock operating mode.

OC	Fundamental clock operating mode	Input pin (OSC1) state
0	Internal oscillator operating mode	Connect to GND
1	External clock operating mode	Input the clock from the outside

(9) SC . . . Segment on/off control data

This control data bit controls the on/off state of the segments.

SC	Display state
0	on
1	off

Note that when the segments are turned off by setting SC to 1, the segments are turned off by outputting segment off waveforms from the segment output pins.

LC75843UGA

(10) BU . . . Normal mode/power-saving mode control data

This control data bit selects either normal mode or power-saving mode.

BU	Mode
0	Normal mode
1	Power saving mode (In this mode, the internal oscillator circuit stops oscillation if the IC is in the internal oscillator operating mode(OC=0) and the IC stops receiving external clock signals if the IC is in the external clock operating mode(OC=1). The common and segment output pins go to the V_{SS} level. However, the S1/P1 to S4/P4 output pins can be used as general-purpose output ports under the control of the data bits P0 to P2. (The general-purpose output port P1 to P4 can not be used as clock output or PWM output).)

LC75843UGA

(11) W10 to W15, W20 to W25, W30 to W35 . . . PWM data of the PWM output

These control data bits set the pulse width of the PWM output P1 to P4. However, when the PWM output function isn't used, these control data bits become invalid. In addition, when the external clock operating frequency is set the $f_{CK2} = 38[\text{kHz}]$ typ (EXF = "1") in external clock operating mode (OC = "1"), these control data bits become invalid.

Wn0	Wn1	Wn2	Wn3	Wn4	Wn5	Pulse width of PWM output
0	0	0	0	0	0	(1/64)×Tp
1	0	0	0	0	0	(2/64)×Tp
0	1	0	0	0	0	(3/64)×Tp
1	1	0	0	0	0	(4/64)×Tp
0	0	1	0	0	0	(5/64)×Tp
1	0	1	0	0	0	(6/64)×Tp
0	1	1	0	0	0	(7/64)×Tp
1	1	1	0	0	0	(8/64)×Tp
0	0	0	1	0	0	(9/64)×Tp
1	0	0	1	0	0	(10/64)×Tp
0	1	0	1	0	0	(11/64)×Tp
1	1	0	1	0	0	(12/64)×Tp
0	0	1	1	0	0	(13/64)×Tp
1	0	1	1	0	0	(14/64)×Tp
0	1	1	1	0	0	(15/64)×Tp
1	1	1	1	0	0	(16/64)×Tp
0	0	0	0	1	0	(17/64)×Tp
1	0	0	0	1	0	(18/64)×Tp
0	1	0	0	1	0	(19/64)×Tp
1	1	0	0	1	0	(20/64)×Tp
0	0	1	0	1	0	(21/64)×Tp
1	0	1	0	1	0	(22/64)×Tp
0	1	1	0	1	0	(23/64)×Tp
1	1	1	0	1	0	(24/64)×Tp
0	0	0	1	1	0	(25/64)×Tp
1	0	0	1	1	0	(26/64)×Tp
0	1	0	1	1	0	(27/64)×Tp
1	1	0	1	1	0	(28/64)×Tp
0	0	1	1	1	0	(29/64)×Tp
1	0	1	1	1	0	(30/64)×Tp
0	1	1	1	1	0	(31/64)×Tp
1	1	1	1	1	0	(32/64)×Tp

Wn0	Wn1	Wn2	Wn3	Wn4	Wn5	Pulse width of PWM output
0	0	0	0	0	1	(33/64)×Tp
1	0	0	0	0	1	(34/64)×Tp
0	1	0	0	0	1	(35/64)×Tp
1	1	0	0	0	1	(36/64)×Tp
0	0	1	0	0	1	(37/64)×Tp
1	0	1	0	0	1	(38/64)×Tp
0	1	1	0	0	1	(39/64)×Tp
1	1	1	0	0	1	(40/64)×Tp
0	0	0	1	0	1	(41/64)×Tp
1	0	0	1	0	1	(42/64)×Tp
0	1	0	1	0	1	(43/64)×Tp
1	1	0	1	0	1	(44/64)×Tp
0	0	1	1	0	1	(45/64)×Tp
1	0	1	1	0	1	(46/64)×Tp
0	1	1	1	0	1	(47/64)×Tp
1	1	1	1	0	1	(48/64)×Tp
0	0	0	0	1	1	(49/64)×Tp
1	0	0	0	1	1	(50/64)×Tp
0	1	0	0	1	1	(51/64)×Tp
1	1	0	0	1	1	(52/64)×Tp
0	0	1	0	1	1	(53/64)×Tp
1	0	1	0	1	1	(54/64)×Tp
0	1	1	0	1	1	(55/64)×Tp
1	1	1	0	1	1	(56/64)×Tp
0	0	0	1	1	1	(57/64)×Tp
1	0	0	1	1	1	(58/64)×Tp
0	1	0	1	1	1	(59/64)×Tp
1	1	0	1	1	1	(60/64)×Tp
0	0	1	1	1	1	(61/64)×Tp
1	0	1	1	1	1	(62/64)×Tp
0	1	1	1	1	1	(63/64)×Tp
1	1	1	1	1	1	(64/64)×Tp

Note : W10 to W15 . . . PWM data of the PWM output (Ch1)
 W20 to W25 . . . PWM data of the PWM output (Ch2)
 W30 to W35 . . . PWM data of the PWM output (Ch3)

$$n=1 \text{ to } 3$$

$$T_p = \frac{1}{f_p}$$

LC75843UGA

Display Data and Output Pin Correspondence (1/4 Duty)

Output pin	COM1	COM2	COM3	COM4
S1/P1	D1	D2	D3	D4
S2/P2	D5	D6	D7	D8
S3/P3	D9	D10	D11	D12
S4/P4	D13	D14	D15	D16
S5	D17	D18	D19	D20
S6	D21	D22	D23	D24
S7	D25	D26	D27	D28
S8	D29	D30	D31	D32
S9	D33	D34	D35	D36
S10	D37	D38	D39	D40
S11	D41	D42	D43	D44
S12	D45	D46	D47	D48
S13	D49	D50	D51	D52

Output pin	COM1	COM2	COM3	COM4
S14	D53	D54	D55	D56
S15	D57	D58	D59	D60
S16	D61	D62	D63	D64
S17	D65	D66	D67	D68
S18	D69	D70	D71	D72
S19	D73	D74	D75	D76
S20	D77	D78	D79	D80
S21	D81	D82	D83	D84
S22	D85	D86	D87	D88
S23	D89	D90	D91	D92
S24	D93	D94	D95	D96
S28	D97	D98	D99	D100

Note: This table assumes that pins S1/P1 to S4/P4 are configured for segment output.

For example, the table below lists the output states for the S21 output pin.

Display data				Output pin (S21) state
D81	D82	D83	D84	
0	0	0	0	The LCD segments corresponding to COM1, COM2, COM3, and COM4 are off.
0	0	0	1	The LCD segment corresponding to COM4 is on.
0	0	1	0	The LCD segment corresponding to COM3 is on.
0	0	1	1	The LCD segments corresponding to COM3 and COM4 are on.
0	1	0	0	The LCD segment corresponding to COM2 is on.
0	1	0	1	The LCD segments corresponding to COM2 and COM4 are on.
0	1	1	0	The LCD segments corresponding to COM2 and COM3 are on.
0	1	1	1	The LCD segments corresponding to COM2, COM3, and COM4 are on.
1	0	0	0	The LCD segment corresponding to COM1 is on.
1	0	0	1	The LCD segments corresponding to COM1 and COM4 are on.
1	0	1	0	The LCD segments corresponding to COM1 and COM3 are on.
1	0	1	1	The LCD segments corresponding to COM1, COM3, and COM4 are on.
1	1	0	0	The LCD segments corresponding to COM1 and COM2 are on.
1	1	0	1	The LCD segments corresponding to COM1, COM2, and COM4 are on.
1	1	1	0	The LCD segments corresponding to COM1, COM2, and COM3 are on.
1	1	1	1	The LCD segments corresponding to COM1, COM2, COM3, and COM4 are on.

LC75843UGA

Display Data and Output Pin Correspondence (1/3 Duty)

Output pin	COM1	COM2	COM3	Output pin	COM1	COM2	COM3
S1/P1	D1	D2	D3	S14	D40	D41	D42
S2/P2	D4	D5	D6	S15	D43	D44	D45
S3/P3	D7	D8	D9	S16	D46	D47	D48
S4/P4	D10	D11	D12	S17	D49	D50	D51
S5	D13	D14	D15	S18	D52	D53	D54
S6	D16	D17	D18	S19	D55	D56	D57
S7	D19	D20	D21	S20	D58	D59	D60
S8	D22	D23	D24	S21	D61	D62	D63
S9	D25	D26	D27	S22	D64	D65	D66
S10	D28	D29	D30	S23	D67	D68	D69
S11	D31	D32	D33	S24	D70	D71	D72
S12	D34	D35	D36	COM4/S25	D73	D74	D75
S13	D37	D38	D39	S28	D76	D77	D78

Note: This table assumes that pins S1/P1 to S4/P4, and COM4/S25 are configured for segment output.

For example, the table below lists the output states for the S21 output pin.

Display data			Output pin (S21) state
D61	D62	D63	
0	0	0	The LCD segments corresponding to COM1, COM2 and COM3 are off.
0	0	1	The LCD segment corresponding to COM3 is on.
0	1	0	The LCD segment corresponding to COM2 is on.
0	1	1	The LCD segments corresponding to COM2 and COM3 are on.
1	0	0	The LCD segment corresponding to COM1 is on.
1	0	1	The LCD segments corresponding to COM1 and COM3 are on.
1	1	0	The LCD segments corresponding to COM1 and COM2 are on.
1	1	1	The LCD segments corresponding to COM1, COM2, and COM3 are on.

Display Data and Output Pin Correspondence (1/2 Duty)

Output pin	COM1	COM2	Output pin	COM1	COM2
S1/P1	D1	D2	S15	D29	D30
S2/P2	D3	D4	S16	D31	D32
S3/P3	D5	D6	S17	D33	D34
S4/P4	D7	D8	S18	D35	D36
S5	D9	D10	S19	D37	D38
S6	D11	D12	S20	D39	D40
S7	D13	D14	S21	D41	D42
S8	D15	D16	S22	D43	D44
S9	D17	D18	S23	D45	D46
S10	D19	D20	S24	D47	D48
S11	D21	D22	COM4/S25	D49	D50
S12	D23	D24	COM3/S26	D51	D52
S13	D25	D26	S28	D53	D54
S14	D27	D28			

Note: This table assumes that pins S1/P1 to S4/P4, COM4/S25, and COM3/S26 are configured for segment output.

For example, the table below lists the output states for the S21 output pin.

Display data		Output pin (S21) state
D41	D42	
0	0	The LCD segments corresponding to COM1 and COM2 are off.
0	1	The LCD segment corresponding to COM2 is on.
1	0	The LCD segment corresponding to COM1 is on.
1	1	The LCD segments corresponding to COM1 and COM2 are on.

LC75843UGA

Display Data and Output Pin Correspondence (1/1 Duty)

Output pin	COM1	Output pin	COM1
S1/P1	D1	S15	D15
S2/P2	D2	S16	D16
S3/P3	D3	S17	D17
S4/P4	D4	S18	D18
S5	D5	S19	D19
S6	D6	S20	D20
S7	D7	S21	D21
S8	D8	S22	D22
S9	D9	S23	D23
S10	D10	S24	D24
S11	D11	COM4/S25	D25
S12	D12	COM3/S26	D26
S13	D13	COM2/S27	D27
S14	D14	S28	D28

Note: This table assumes that pins S1/P1 to S4/P4, COM4/S25, COM3/S26, and COM2/S27 are configured for segment output.

For example, the table below lists the output states for the S21 output pin.

Display data	Output pin (S21) state
D21	
0	The LCD segment corresponding to COM1 is off.
1	The LCD segment corresponding to COM1 is on.

LC75843UGA

Output waveforms (1/4-Duty 1/3-Bias Drive Scheme)

