



Chipsmall Limited consists of a professional team with an average of over 10 year of expertise in the distribution of electronic components. Based in Hongkong, we have already established firm and mutual-benefit business relationships with customers from,Europe,America and south Asia,supplying obsolete and hard-to-find components to meet their specific needs.

With the principle of “Quality Parts,Customers Priority,Honest Operation,and Considerate Service”,our business mainly focus on the distribution of electronic components. Line cards we deal with include Microchip,ALPS,ROHM,Xilinx,Pulse,ON,Everlight and Freescale. Main products comprise IC,Modules,Potentiometer,IC Socket,Relay,Connector.Our parts cover such applications as commercial,industrial, and automotives areas.

We are looking forward to setting up business relationship with you and hope to provide you with the best service and solution. Let us make a better world for our industry!



Contact us

Tel: +86-755-8981 8866 Fax: +86-755-8427 6832

Email & Skype: info@chipsmall.com Web: www.chipsmall.com

Address: A1208, Overseas Decoration Building, #122 Zhenhua RD., Futian, Shenzhen, China





LC7932, 7932M — CMOS IC 16-Bit LED Driver

Overview

The LC7932, 7932M are LSIs that contain a 16-bit bidirectional shift register and are capable of direct driving a multiple lighting LED (dot matrix or dot array). The LC7932, 7932M are especially suited for use in LED display panel, PPC photosensitive drum LED erase head applications.

Features

- Silicon gate C-MOS device capable of high-speed, high-current drive.
- High-speed shiftable 16-bit bidirectional shift register/16-bit latch/output control circuit/16-bit N-channel transistor open drain output transistor on chip.
- Serial shift data is shifted on the positive transition of the clock (CLOCK) pulse.
- The data latch circuit outputs input data when the latch control (LATCH) pin is at L-level and holds output data when the latch control (LATCH) pin is at H-level.
- Maximum ratings of driver output: $V_O = +15V$, $I_{OL} = 30mA$ (STATIC)/120mA(DYNAMIC).
- Operating voltage of logic unit: $V_{DD} = 4.5V$ to $5.5V$
- Operating clock frequency: $f_{CLK} = DC$ to $5MHz$ (max).
- Package: LC7932 : DIP30S
LC7932M : MFP30S
- The bidirectional shift register is so designed as to cause a shift to occur in the SI to SO direction when L/R = L-level and in the SO to SI direction when L/R = H-level.
- When a high level is applied to the LSET pin ("latch set"), the latch data is set to the high level. The latch data does not change when the LSET pin is low or open.

Package Dimensions

unit:mm

3061-DIP30S

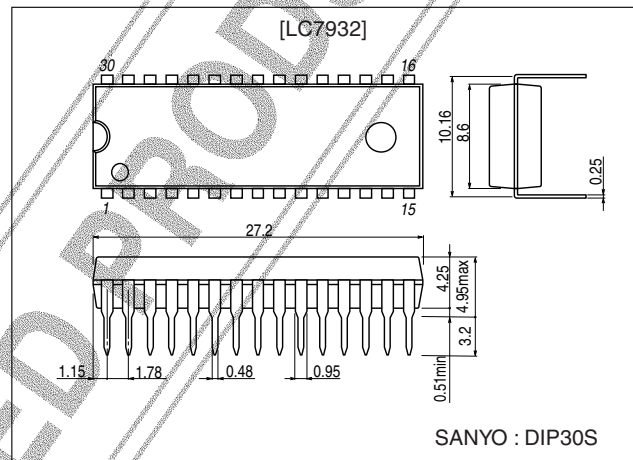

unit:mm

3073B-MFP30SD

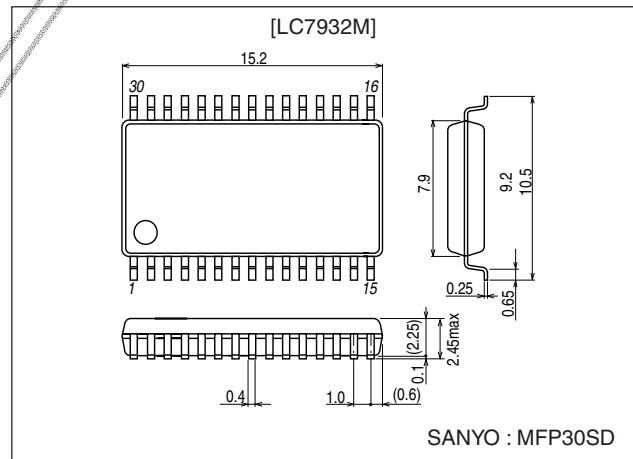

■ Any and all SANYO Semiconductor products described or contained herein do not have specifications that can handle applications that require extremely high levels of reliability, such as life-support systems, aircraft's control systems, or other applications whose failure can be reasonably expected to result in serious physical and/or material damage. Consult with your SANYO Semiconductor representative nearest you before using any SANYO Semiconductor products described or contained herein in such applications.

■ SANYO Semiconductor assumes no responsibility for equipment failures that result from using products at values that exceed, even momentarily, rated values (such as maximum ratings, operating condition ranges, or other parameters) listed in products specifications of any and all SANYO Semiconductor products described or contained herein.

LC7932, 7932M

Specifications

Absolute Maximum Ratings at Ta = 25°C

Parameter	Symbol	Conditions	Ratings	Unit
Maximum supply voltage	V _{DD max}		-0.3 to +7.0	V
Input voltage	V _I		-0.3 to V _{DD} +0.3	V
Output voltage	V _{O1}	SOUT (SIN) output	-0.3 to V _{DD} +0.3	V
	V _{O2}	D1 to D16 output, output Tr OFF	15	V
Output current	I _O	D1 to D16 output, per output pin	30	mA
			400	mW
Allowable power dissipation	Pd max	LC7932 Ta = 85°C	400	mW
		LC7932M Ta = 85°C	270	mW
Operating temperature	T _{opr}		-25 to +85	°C
Storage temperature	T _{stg}	(Note)	-35 to +125	°C

Note

When mounting the MFP package version, do not dip it in solder.

Allowable Operating Conditions at Ta = -25°C to +85°C

Parameter	Symbol	Conditions	Ratings			Unit
			min	typ	max	
Supply voltage	V _{DD}	V _{DD}	4.5		5.5	V
Input high-level voltage	V _{IH}	SIN (SOUT), CLOCK, LATCH, BEO, STROBE, LSET, L/R	0.8V _{DD}		V _{DD}	V
Input low-level voltage	V _{IL}	SIN (SOUT), CLOCK, LATCH, BEO, STROBE, LSET, L/R	V _{SS(L)}		0.2V _{DD}	V
Clock frequency	f _{CLK}	CLOCK: Duty: 50%			5.0	MHz
Clock pulse width	t _{Wφ}	CLOCK	75			ns
Clock rise/fall time	t _r , t _f	CLOCK			200	ns
Data setup time	t _{DS}	SIN (SOUT), CLOCK	100			ns
Data hold time	t _{DH}	SIN (SOUT), CLOCK	50			ns
Latch pulse width	t _{WL}	LATCH	100			ns

Electrical Characteristics at Ta = 25°C

Parameter	Symbol	Conditions	Ratings			Unit
			min	typ	max	
Input high-level voltage	I _{IH1}	SIN (SOUT), CLOCK, LATCH, L/R			10	μA
	I _{IH2}	BEO, LSET		170		μA
Input low-level current	I _{IL1}	SIN (SOUT), CLOCK, LATCH, L/R	-10			μA
	I _{IL2}	STROBE		170		μA
Output high-level voltage	V _{OH}	SOUT (SIN): I _{OH} =-0.5mA, V _{DD} =5V	V _{DD} -0.5			V
Output low-level voltage	V _{OL1}	SOUT (SIN): I _{OL} =0.5mA, V _{DD} =5V			0.5	V
	V _{OL2}	D1 to D16: I _{OL} =30mA, V _{DD} =5V			0.5	V
Output OFF-state leakage current	I _{OFF}	D1 to D16: V _O =15V			20	μA
Input capacitance	C _{IN}	CLOCK		5.0		pF
Operating current	I _{DD}	V _{DD} ; f _{CLK} =5MHz, V _{DD} =5V, All outputs with no load			5	mA

Switching Characteristics at Ta = 25°C

Parameter	Symbol	Conditions	Ratings			Unit
			min	typ	max	
Clock latch delay width	t _{CL}	CLOCK, LATCH: V _{DD} =5V	100			ns
Latch clock delay width	t _{LC}	CLOCK, LATCH: V _{DD} =5V	0			ns
Output high-level propagation delay time	t _{PLH1}	LATCH, D1 to D16: Dn; (RL=1.0kΩ, CL=15pF), V _{DD} =5V			400	ns
	t _{PLH2}	BEO, STROBE, D1 to D16: Dn; (RL=1.0kΩ, CL=15pF), V _{DD} =5V			300	ns
	t _{PLH3}	CLOCK, SOUT (SIN) : SOUT; CL=15pF, V _{DD} =5V			200	ns
Output low-level propagation delay time	t _{PHL1}	LATCH, LSET, D1 to D16: Dn; (RL=1.0kΩ, CL=15pF), V _{DD} =5V			200	ns
	t _{PHL2}	BEO, STROBE, D1 to D16: Dn; (RL=1.0kΩ, CL=15pF), V _{DD} =5V			100	ns
	t _{PHL3}	CLOCK, SOUT (SIN) : SOUT; CL=15pF, V _{DD} =5V			200	ns

LC7932, 7932M

Equivalent Circuit

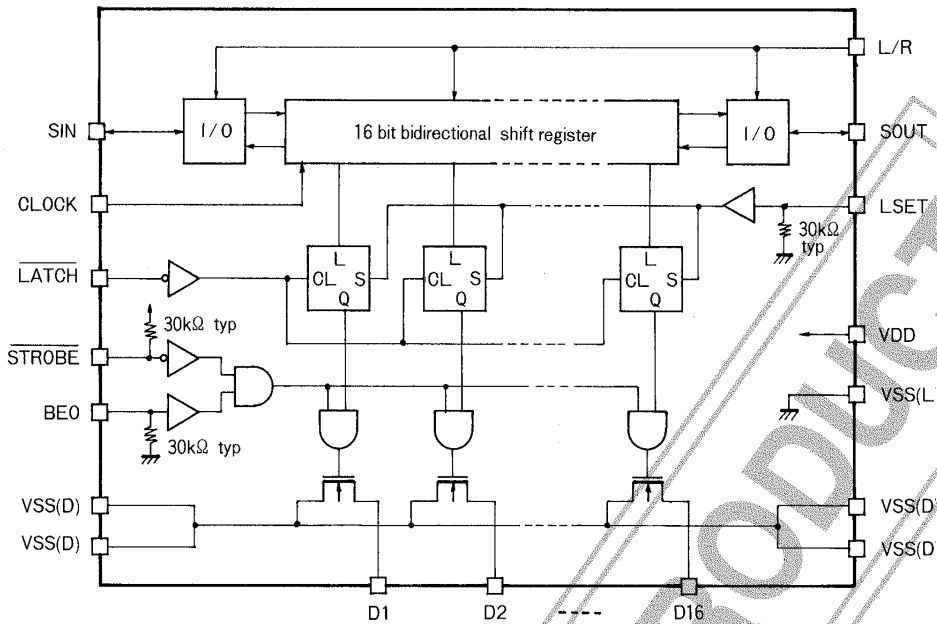

Pin Assignment

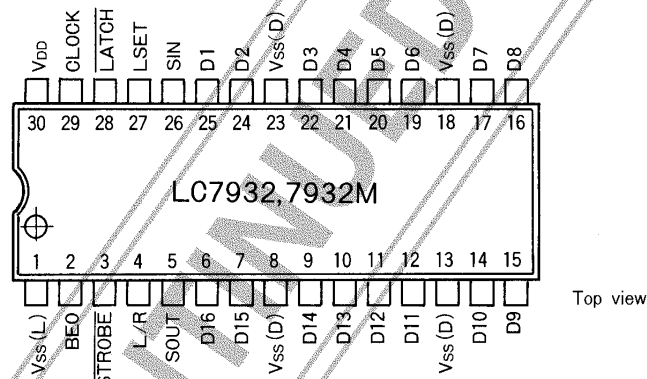

The package comes in two types-DIP30S and MFP30S.

LED Driver ON/OFF Truth Table

Latch Data (Q)	BE0	STROBE	LED Driver
0	0	0	OFF
1	0	0	OFF
0	1	0	OFF
1	1	0	ON Driver ON
0	0	1	OFF
1	0	1	OFF
0	1	1	OFF
1	1	1	OFF

Input Data Timing Chart

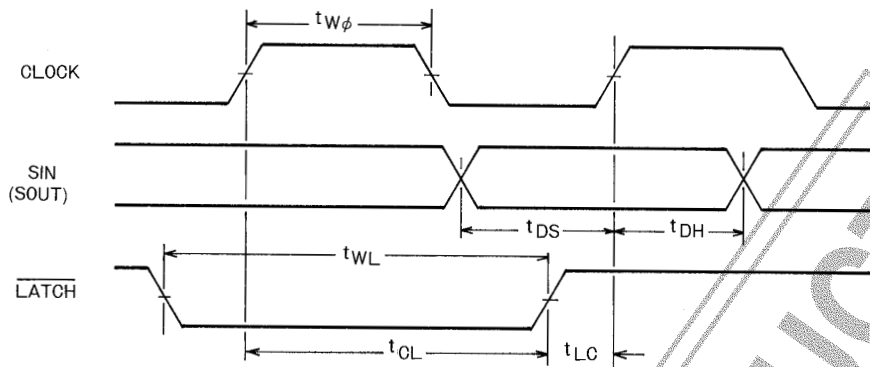

Output Data Timing Chart

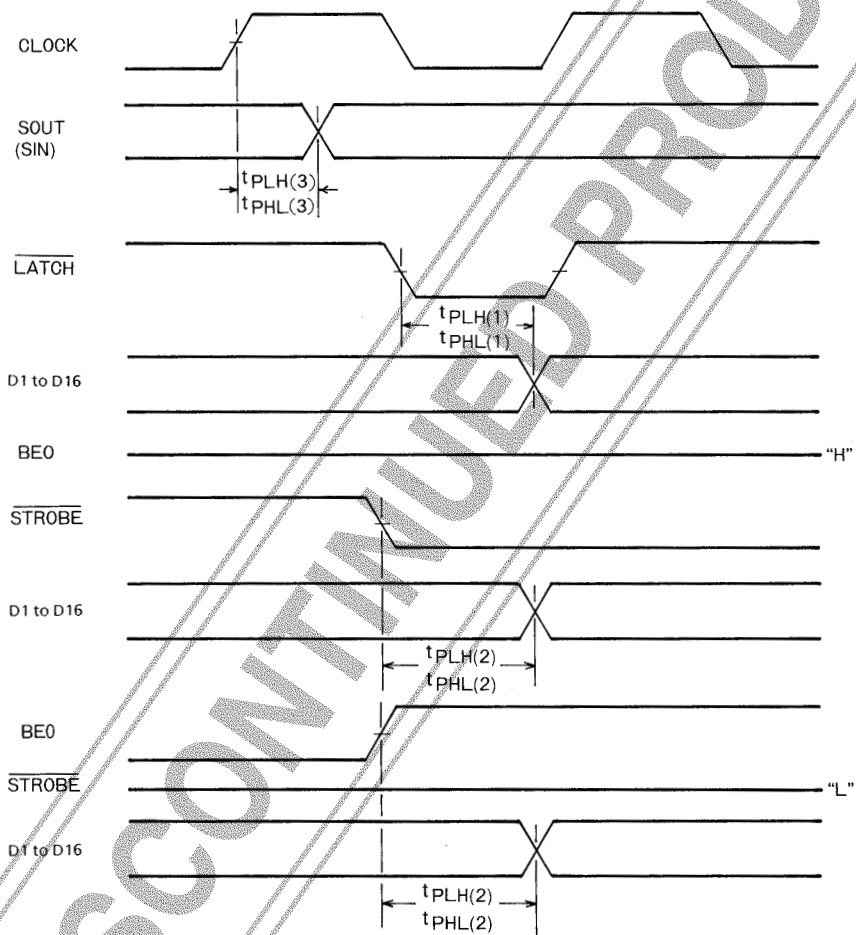

DISCONTINUED PRODUCT

Equivalent Circuit for Output Driver Section

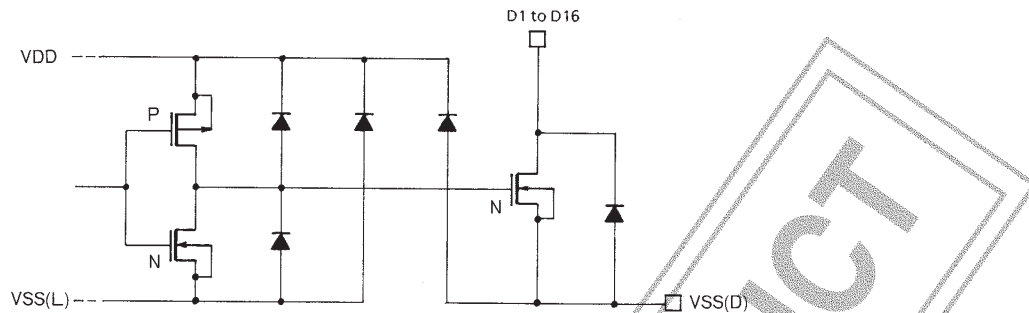

Note

L/R = H-level : ()

- Specifications of any and all SANYO Semiconductor products described or contained herein stipulate the performance, characteristics, and functions of the described products in the independent state, and are not guarantees of the performance, characteristics, and functions of the described products as mounted in the customer's products or equipment. To verify symptoms and states that cannot be evaluated in an independent device, the customer should always evaluate and test devices mounted in the customer's products or equipment.
- SANYO Semiconductor Co., Ltd. strives to supply high-quality high-reliability products. However, any and all semiconductor products fail with some probability. It is possible that these probabilistic failures could give rise to accidents or events that could endanger human lives, that could give rise to smoke or fire, or that could cause damage to other property. When designing equipment, adopt safety measures so that these kinds of accidents or events cannot occur. Such measures include but are not limited to protective circuits and error prevention circuits for safe design, redundant design, and structural design.
- In the event that any or all SANYO Semiconductor products (including technical data, services) described or contained herein are controlled under any of applicable local export control laws and regulations, such products must not be exported without obtaining the export license from the authorities concerned in accordance with the above law.
- No part of this publication may be reproduced or transmitted in any form or by any means, electronic or mechanical, including photocopying and recording, or any information storage or retrieval system, or otherwise, without the prior written permission of SANYO Semiconductor Co., Ltd.
- Any and all information described or contained herein are subject to change without notice due to product/technology improvement, etc. When designing equipment, refer to the "Delivery Specification" for the SANYO Semiconductor product that you intend to use.
- Information (including circuit diagrams and circuit parameters) herein is for example only; it is not guaranteed for volume production. SANYO Semiconductor believes information herein is accurate and reliable, but no guarantees are made or implied regarding its use or any infringements of intellectual property rights or other rights of third parties.

This catalog provides information as of June, 2001. Specifications and information herein are subject to change without notice.