



Chipsmall Limited consists of a professional team with an average of over 10 year of expertise in the distribution of electronic components. Based in Hongkong, we have already established firm and mutual-benefit business relationships with customers from,Europe,America and south Asia,supplying obsolete and hard-to-find components to meet their specific needs.

With the principle of "Quality Parts,Customers Priority,Honest Operation,and Considerate Service",our business mainly focus on the distribution of electronic components. Line cards we deal with include Microchip,ALPS,ROHM,Xilinx,Pulse,ON,Everlight and Freescale. Main products comprise IC,Modules,Potentiometer,IC Socket,Relay,Connector.Our parts cover such applications as commercial,industrial, and automotives areas.

We are looking forward to setting up business relationship with you and hope to provide you with the best service and solution. Let us make a better world for our industry!



Contact us

Tel: +86-755-8981 8866 Fax: +86-755-8427 6832

Email & Skype: info@chipsmall.com Web: www.chipsmall.com

Address: A1208, Overseas Decoration Building, #122 Zhenhua RD., Futian, Shenzhen, China



LC823433TA

CMOS LSI

Audio Processing System LSI for MP3 Record and Playback Devices



ON Semiconductor®

www.onsemi.com

Overview

LC823433TA is an audio processing system for MP3 record and playback devices.

It integrates DSP for digital signal processing and analog blocks such as audio ADC, audio DAC, and speaker and headphone amplifier in addition to LCD segment driver.

Features

- 32bit LPDSP32
 - SRAM (246KB)
 - PM 75KB (40KB + 35KB : ISOLATED)
 - DMA 170KB (16KB + 154KB:ISOLATED)
 - DMB 1KB (ISOLATED)ISOLATED area : Power ON/OFF control is available by register.
 - ROM (264.5KB)
 - PM 227.5KB (ISOLATED)
 - DMA 34KB (ISOLATED)
 - DMB 3KB (ISOLATED)ISOLATED area : Power ON/OFF control is available by the register.
 - SIO (Clock Serial IO 2ch)
 - SIO0 : Ch0 eSIO (Clock speed = Sysclk/1 (max))
program load and execute is possible using Serial Flash
(after internal ROM Boot)
 - SIO1 : Ch1 SIO (Clock speed = Sysclk/8 (max))
 - UART (1ch)
 - I²C (1ch Single Master, Full/Standard)
 - Plain Timer (2ch)
 - Timer0 : w/ Watch Dog Timer
 - Timer1 : w/o Watch Dog Timer and XT1 operation
 - Multiple Timer (2ch)
PWM output (1ch)
 - RTC (Real Time Clock)
Operating voltage is independent of internal core operating voltage.
Only RTC power supply can be active during all others inactive (ISOLATED).

Continued on next page.

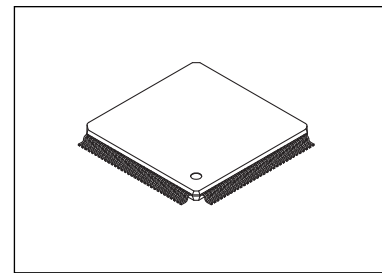

TQFP128 14x14 / TQFP128L

* I²C Bus is a trademark of Philips Corporation.

ORDERING INFORMATION

See detailed ordering and shipping information on page 20 of this data sheet.

LC823433TA

Continued from preceding page.

- SD card IF (2ch) (w/o CPRM)
eSD/eMMC can be connected.
 - SD ch0 : program load and execute using eSD/eMMC (after internal ROM Boot) is possible.
 - SD ch1 : SD card
- USB2.0 (480Mbps/12Mbps) Device IF. built-in PHY
- 10bit A/D converter (3ch)
- GPIO (31ch)
(GPIOs share the terminals with other functions. Refer to the terminal list in detail).
 - LCD controller, LCD Driver. 18SEG * 8COM, 1/8Duty, 1/4Bias
- Internal ROM Boot is possible.
- Firmware writing function.
The firmware reading from SD ch1 and writing to the following devices:
 - Serial Flash connected SIO0.
 - eMMC/eSD connected SD ch0.
- JTAG (for debugger)

- Audio Functions
 - Record and Playback
 - Compression method : MP3¹ (MPEG1/2/2.5 Layer3). Stereo/Mono compatible.
 - Sampling frequencies : 8kHz, 11.025kHz, 12kHz, 16kHz, 22.05kHz, 24kHz, 32kHz, 44.1kHz, and 48kHz
 - Bitrate : 8kbps (*1) to 320kbps (for Decoder-VBR)
(*1) Encoder supports only Mono (one channel) for 8Kbps.
 - Adjusting the playback speed
 - Fast playback : 1.0 times to 2.0 times 10 steps.
 - Slow playback : 0.5 times to 1.0 times 10 steps.
 - Multipurpose filter
 - Audio data automatic transfer function
 - The audio buffer executes the data transfer between internal SRAM (DMA) and the audio block.
Wait cycle(s) is inserted to the LPDSP32 access to the SRAM while the audio buffer accesses to internal SRAM(DMA).
 - Digital volume, digital mute, BEEP, and level meter
 - The interrupt generation function at the operation completion
(e.g. interrupt at mute completion).
 - Audio timer
 - LR clock count and the interrupt generation function.
 - Flexible PCM audio interface (two interfaces)
 - Master/Slave Mode Selectable
 - Data Formats : I²S mode etc.
 - Sample Rate Converters
 - 0.5times to 64 times conversion range.
 - Digital microphone IF (2ch)

Continued on next page.

¹ MPEG Layer-3 audio coding technology licensed from Fraunhofer IIS and Thomson.

Supply of this product does not convey license nor imply any right to distribute content created with this product in revenue-generating broadcast systems (terrestrial, satellite, cable and/or other distribution channels), streaming applications (via Internet, intranets and/or networks), other content distribution systems (pay-audio or audio-on-demand applications and the like) or on physical media (compact discs, digital versatile discs, semiconductor chips, hard drives, memory cards and the like).

Supply of this product does not convey license under the relevant intellectual property of Thomson and/or Fraunhofer Gesellschaft nor imply any right to use this product in any finished end user or ready-to-use final product. An independent license for such use is required. For details, please visit <http://mp3licensing.com/>.

LC823433TA

Continued from preceding page.

- Analog function

- Microphone amplifier 0/18/24/30dB (2ch)
- PGA with ALC -12dB to 35.25dB in 0.75dB steps (2ch)
- 16 bit $\Delta\Sigma$ ADC (2ch)
- Digital filter for 16 bits $\Delta\Sigma$ DAC (2ch)
- AB class amplifier

The power supply only to AB class amplifier is possible (ISOLATED).

Thermal shutdown circuit built-in

- Speaker amplifier (1ch BTL) 1dB to 4.5dB in 0.5dB steps
Maximum output 300mW @3.0V, Speaker = 8[Ω], 1dB
- Headphone amplifier (2ch) 0dB to 3dB in 1dB steps (Only same gain setting to 2ch is possible)
Maximum output 5mW @3.0V, HeadPhone = 16[Ω], Rd (Series) = 33[Ω], 1dB

- Clock

- RCOSC : Internal RC oscillation. 1MHz (TYP.)
- XT1 : Main XTAL. 32.768kHz.
Used as an original oscillation of the system clock and the audio clock, and a RTC clock.
- XT2 : Optional XTAL. 12MHz (TYP) etc.
- PLL1 : For system clock generation (LPDSP32 is included).
- PLL2 : For audio clock generation

Specification

- Supply voltage : 1.3V (core, etc), 3.15V (Audio, USB, etc)
- Maximum operation frequency : 42MHz (DSP@1.3V)
- Package : 128pin TQFP

Application

- IC Recorder, Audio Player
- Radio Recorder, Home Audio (Mini compo)

LC823433TA

Specifications

Absolute Maximum Ratings at $V_{SS} = 0V$

Parameter	Symbol	Domain of applicability	Ratings	Unit
Supply voltage	VDD1 VDDRTC AVDDPLL1 AVDDPHY1		-0.3 to +1.8	V
	VDD2 VDDLCD AVDDPLL2 AVDDADC AVDDAADC AVDDADAC AVDDSPAMP AVDDPHY2		-0.3 to +3.96	V
Input voltage	V_I		-0.3 to $*V_{DD}^*+0.3$ (Max 3.96)	V
Operating temperature	T_{opr}		-20 to +75	°C
Storage temperature	T_{stg}		-55 to +125	°C

Stresses exceeding those listed in the Maximum Ratings table may damage the device. If any of these limits are exceeded, device functionality should not be assumed, damage may occur and reliability may be affected.

Recommended Operating Conditions at $T_a = -20^{\circ}C$ to $+75^{\circ}C$

Parameter	Symbol	Test Conditions	min	typ	max	Unit
Supply voltage	VDD1		1.15	1.3	1.65	V
	VDDRTC		0.9	1.5	1.65	V
	AVDDPLL1		1.15	1.3	1.65	V
	VDD2		2.7	3.15	3.3	V
	VDDLCD		2.7	3.15	3.3	V
	AVDDPLL2		2.7	3.15	3.3	V
	AVDDADC		2.7	3.15	3.3	V
	AVDDAADC		2.7	2.8	3.3	V
	AVDDADAC		2.7	2.8	3.3	V
	AVDDSPAMP		1.8	3.15	3.8	V
	AVDDPHY1		1.35	1.5	1.65	V
	AVDDPHY2		3.0	3.15	3.6	V
Input voltage	V_{IN}		0		$*V_{DD}^*$	V
	V_{IN}^3 (RTC)		0		3.6	V
	V_{IN_ADC} (AN0-AN2).	$I_{AN} < 300\mu A$	0		3.3	V

Functional operation above the stresses listed in the Recommended Operating Ranges is not implied. Extended exposure to stresses beyond the Recommended Operating Ranges limits may affect device reliability.

LC823433TA

DC Characteristics at $T_a = -20^{\circ}\text{C}$ to $+75^{\circ}\text{C}$, $V_{DD1} = 1.15\text{V}$ to 1.65V , $V_{DD2} = 2.7\text{V}$ to 3.3V ,
 $V_{DDRTC} = 0.9\text{V}$ to 1.65V

Parameter	Symbol	Application	Test Conditions	min	typ	max	Unit
Input high voltage	V_{IH}	3ICUD		$0.7 \times V_{DD2}$			V
		3IS, 3ISUD	Schmitt	$0.75 \times V_{DD2}$			V
		1IC		$0.7 \times V_{DDRTC}$			V
		1IS	Schmitt	$0.7 \times V_{DDRTC}$			V
Input low voltage	V_{IL}	3ICUD				$0.3 \times V_{DD2}$	V
		3IS, 3ISUD	Schmitt			$0.25 \times V_{DD2}$	V
		1IC				$0.2 \times V_{DDRTC}$	V
		1IS	Schmitt			$0.2 \times V_{DDRTC}$	V
Input high leakage current	I_{IH}	3ICUD, 3IS, 3ISUD	$V_{IN} = V_{DD2}$			10	μA
		1IC, 1IS	$V_{IN} = 3.3\text{V}$			10	μA
Input low leakage current	I_{IL}	3IS, 3ISUD	$V_{IN} = V_{SS}$	-10			μA
		1IC, 1IS	$V_{IN} = V_{SSRTC}$	-10			μA
Output high voltage	V_{OH}	3T2	$I_{OH} = -2\text{mA}$	$V_{DD2} - 0.4$			V
		3T4	$I_{OH} = -4\text{mA}$	$V_{DD2} - 0.4$			V
		3T4(8)	$I_{OH} = -4\text{mA}$ ($I_{OH} = -8\text{mA}$)	$V_{DD2} - 0.4$			V
		3T6(12)	$I_{OH} = -6\text{mA}$ ($I_{OH} = -12\text{mA}$)	$V_{DD2} - 0.4$			V
Output low voltage	V_{OL}	3T2	$I_{OL} = 2\text{mA}$			0.4	V
		3T4	$I_{OL} = 4\text{mA}$			0.4	V
		3T4(8)	$I_{OL} = 4\text{mA}$ ($I_{OL} = 8\text{mA}$)			0.4	V
		3T6(12)	$I_{OL} = 6\text{mA}$ ($I_{OL} = 12\text{mA}$)			0.4	V
		OD3	$I_{OL} = 0.3\text{mA}$			0.3	V
Output leakage current	I_{OZ}	3T2, 3T4, 3T4(8), 3T6(12)	When it outputs Hi-Z	-10		10	μA
Pull-up resistor	Rup	3ICUD, 3ISUD		30	80	190	$\text{k}\Omega$
Pull-down resistor	Rdn	3ICUD, 3ISUD		30	80	190	$\text{k}\Omega$

Product parametric performance is indicated in the Electrical Characteristics for the listed test conditions, unless otherwise noted. Product performance may not be indicated by the Electrical Characteristics if operated under different conditions.

LC823433TA

Package Dimensions

unit : mm

TQFP128 14x14 / TQFP128L

CASE 932BA

ISSUE A

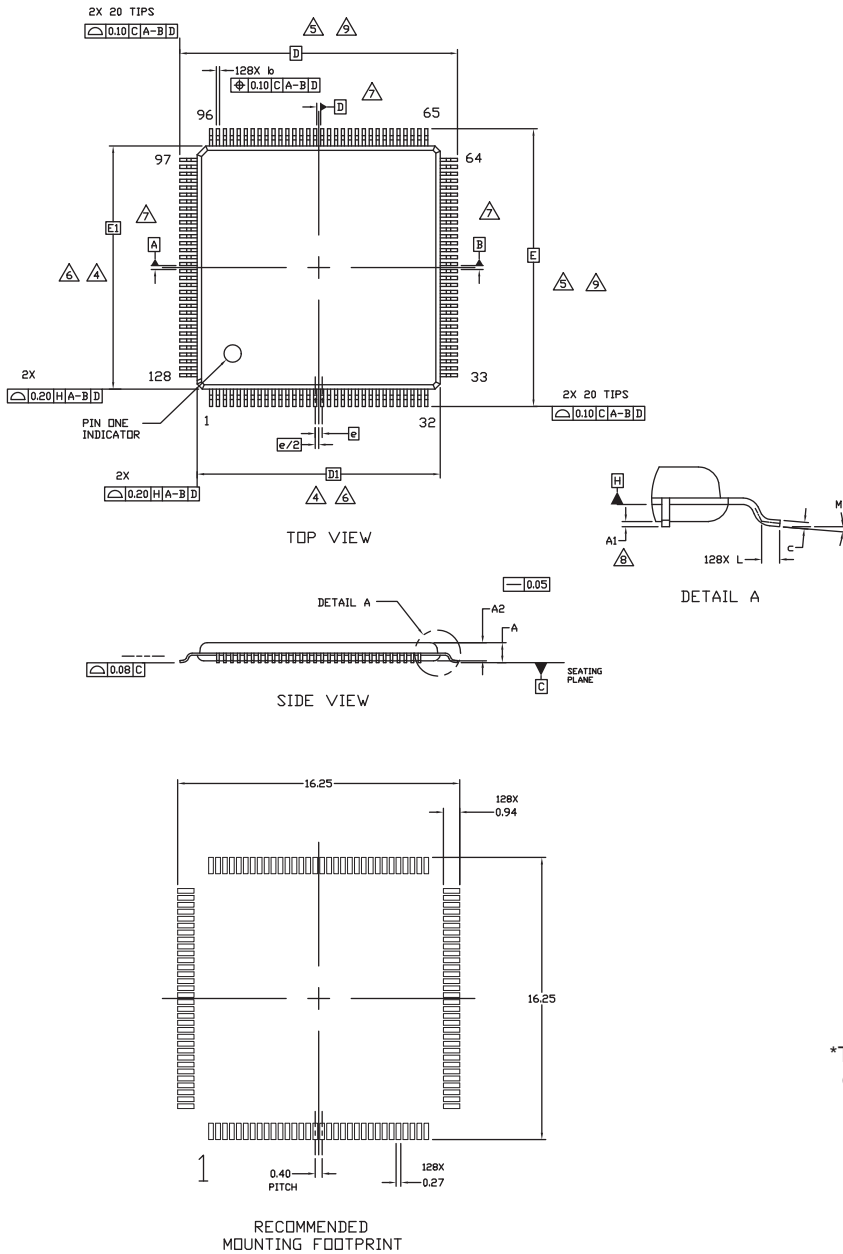

- NOTES:
1. DIMENSIONING AND TOLERANCING PER ASME Y14.5M, 1994.
 2. CONTROLLING DIMENSION MILLIMETERS
 3. DIMENSION b DOES NOT INCLUDE DAMBAR PROTRUSION. DAMBAR PROTRUSION SHALL BE 0.08 MAX. AT MMC. DAMBAR CANNOT BE LOCATED ON THE LOWER RADIUS OF THE FOOT. MINIMUM SPACE BETWEEN PROTRUSION AND ADJACENT LEAD IS 0.07.
 4. DIMENSIONS D1 AND E1 DO NOT INCLUDE MOLD FLASH, PROTRUSIONS, OR GATE BURRS. MOLD FLASH, PROTRUSIONS, OR GATE BURRS SHALL NOT EXCEED 0.25 PER SIDE. DIMENSIONS D1 AND E1 ARE MAXIMUM PLASTIC BODY SIZE INCLUDING MOLD MISMATCH.
 5. THE TOP PACKAGE BODY SIZE MAY BE SMALLER THAN THE BOTTOM PACKAGE SIZE BY AS MUCH AS 0.15.
 6. DIMENSIONS D1 AND E1 TO BE DETERMINED AT DATUM PLANE H.
 7. DATUMS A-B AND D ARE DETERMINED AT DATUM PLANE H.
 8. A1 IS DEFINED AS THE VERTICAL DISTANCE FROM THE SEATING PLANE TO THE LOWEST POINT ON THE PACKAGE BODY.
 9. DIMENSIONS D AND E TO BE DETERMINED AT DATUM PLANE C.

DIM	MILLIMETERS	
	MIN.	MAX.
A	---	1.20
A1	0.05	0.15
A2	1.00	REF
b	0.13	0.23
c	0.09	0.20
D	16.00	BSC
D1	14.00	BSC
E	16.00	BSC
E1	14.00	BSC
e	0.40	BSC
L	0.45	0.75
M	0*	7*

GENERIC MARKING DIAGRAM*

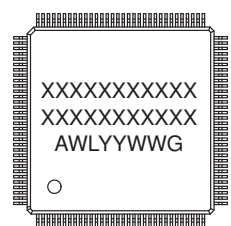

- A = Assembly Location
- WL = Wafer Lot
- YY = Year
- WW = Work Week
- G = Pb-Free Package

*This information is generic. Please refer to device data sheet for actual part marking. Pb-Free indicator, "G" or microdot "■", may or may not be present.

LC823433TA

Pin Assignment (Bonding Option)

Direction		Attribute			
I	Input pin	3IS	3V Schmitt input	1IS	1V Schmitt input. (3V tolerant correspondence)
O	Output pin	3ICUD	3V CMOS input pull-up/down	1IC	1V CMOS input (3V tolerant correspondence)
B	Bidirectional pin	3ISUD	3V Schmitt input pull-up/down	OD3	1V 0.3mA open drain output (3V tolerant correspondence)
P	Power supply pin	3T2	3V 2mA tristate output		
		3T4	3V 4mA tristate output	X	Oscillation amplifier
		3T4(8)	Tristate output with 3V 4mA/8mA switch function	3A	3V analog through
		3T6(12)	Tristate output with 3V 6mA/12mA switch function	1A	1V analog through

TQFP128L Pin No.	Name	Direction	Attribute
1	AV _{SS} SPAMP	P	
2	AV _{DD} SPAMP	P	
3	AVREFSP	O	3A
4	HPINL/SPKINM	I	3A
5	HPINR	I	3A
6	AV _{SS} ADAC	P	
7	OUTMR	O	3A
8	OUTML/OUTM	O	3A
9	AV _{DD} ADAC	P	
10	AV _{SS} AADC	P	
11	AVREF	O	3A
12	AV _{DD} AADC	P	
13	AINL	I	3A
14	AINR	I	3A
15	AV _{DD} ADC	P	
16	AN0	I	3A
17	AN1	I	3A
18	AN2	I	3A
19	V _{SS}	P	
20	V _{DD2}	P	
21	V _{DD1}	P	
22	TIOCA0/P10	B/B	3ISUD/3T2
23	BMODE0	I	3IS
24	BMODE1	I	3IS
25	BMODE2	I	3IS
26	NRES	I	3IS
27	SDCLK1/MCLK1/P00	O/B/B	3ISUD/3T6(12)
28	SDCMD1/LRCK1/P02	B/O/B	3ISUD/3T4(8)
29	SDAT10/BCK1/P03	B/B/B	3ISUD/3T4(8)
30	SDAT11/DIN1/P04	B/I/B	3ICUD/3T4(8)
31	SDAT12/DOUT1/P05	B/O/B	3ICUD/3T4(8)
32	SDAT13/SDO1/P06	B/O/B	3ICUD/3T4(8)
33	SDWP1/SDI1/P01	I/I/B	3ISUD/3T2
34	SDCD1/SCK1/P0A	I/B/B	3ISUD/3T2
35	SDCLK0/P14	O/B	3ICUD/3T6(12)
36	V _{DD2}	P	
37	V _{SS}	P	
38	SDCMD0/P15	B/B	3ICUD/3T4(8)

Continued on next page.

LC823433TA

Continued from preceding page.

TQFP128L Pin No.	Name	Direction	Attribute
39	SDAT03/P16	B/B	3ICUD/3T4(8)
40	SDAT02/P17/SYSCLK	B/B/O	3ICUD/3T4(8)
41	SDAT01/P18/AUD0CLK	B/B/O	3ICUD/3T4(8)
42	SDAT00/P19/AUD1CLK	B/B/O	3ICUD/3T4(8)
43	V _{SS}	P	
44	XIN2	I	X
45	XOUT2	O	X
46	AV _{DD} PHY1(+V _{DD} 1)	P	
47	AV _{SS} PHY1	P	
48	AV _{SS} PHY1	P	
49	RREF	B	3A
50	AV _{SS} PHY2	P	
51	AV _{DD} PHY2	P	
52	AV _{DD} PHY2	P	
53	AV _{SS} PHY2	P	
54	AV _{SS} PHY2	P	
55	AV _{SS} PHY2	P	
56	AV _{DD} PHY2	P	
57	DP	B	3A
58	DM	B	3A
59	AV _{SS} PHY2	P	
60	AV _{DD} PHY2	P	
61	COM0	O	3A
62	COM1	O	3A
63	COM2	O	3A
64	COM3	O	3A
65	V _{DD} LCD	P	
66	VLCD1	O	3A
67	VLCD2	O	3A
68	VLCD3	O	3A
69	V _{SS}	P	
70	V _{DD} 1	P	
71	SEG0	O	3A
72	SEG1	O	3A
73	SEG2	O	3A
74	SEG3	O	3A
75	SEG4	O	3A
76	SEG5	O	3A
77	SEG6	O	3A
78	SEG7	O	3A
79	SEG8	O	3A
80	SEG9	O	3A
81	SEG10	O	3A
82	SEG11	O	3A
83	SEG12	O	3A
84	SEG13	O	3A
85	SEG14	O	3A
86	SEG15	O	3A
87	SEG16	O	3A
88	SEG17	O	3A
89	COM4	O	3A
90	COM5	O	3A

Continued on next page.

LC823433TA

Continued from preceding page.

TQFP128L Pin No.	Name	Direction	Attribute
91	COM6	O	3A
92	COM7	O	3A
93	HPDET/SDI1/SCL/P1A	I/I/O/B	3ISUD/3T2
94	HPMUTE/SDO1/SDA/P1B	O/O/B/B	3ISUD/3T2
95	JTDO/P1C	O/B	3ICUD/3T2
96	JTDI/P1D	I/B	3ICUD/3T2
97	JTMS/P1E	I/B	3ICUD/3T2
98	JTCK/P1F	I/B	3ICUD/3T2
99	V _{DD1}	P	
100	V _{DD2}	P	
	SFMODE (Internal Signal)	I	3IS
101	V _{SS}	P	
102	TXD/SCL/P12	O/O/B	3ISUD/3T2
103	RXD/SDA/P13	I/B/B	3ISUD/3T2
104	SCK0/P07	B/B	3ISUD/3T4
105	SDO0/P08	O/B	3ISUD/3T4
106	SDI0/P09	I/B	3ISUD/3T2
107	MCLK0/DMCKO/SCK1/P0B	B/O/B/B	3ISUD/3T2
108	DIN0/DMDIN/P0F	I/I/B	3ISUD/3T2
109	DOUT0/P0E/NCS	O/B/O	3ISUD/3T2
110	KEYINT1	I	1IS
111	KEYINT0	I	1IS
112	RTCRSTB	I	1IC
113	PWRON	O	OD3
114	LINEFIXB	I	1IS
115	XOUT32K	O	X
116	XIN32K	I	X
117	V _{DD} RTC	P	
	RTCMODE (Internal Signal)	I	1IS
118	V _{SS} RTC	P	
119	AV _{DD} PLL1	P	
120	VCNT1	O	1A
121	V _{SS}	P	
122	AV _{DD} PLL2	P	
123	VCNT2	O	3A
124	AV _{SS} PLL2	P	
125	HPOUTR	O	3A
126	HPOUTL	O	3A
127	SPOUTP	O	3A
128	SPOUTN	O	3A

Block Diagram

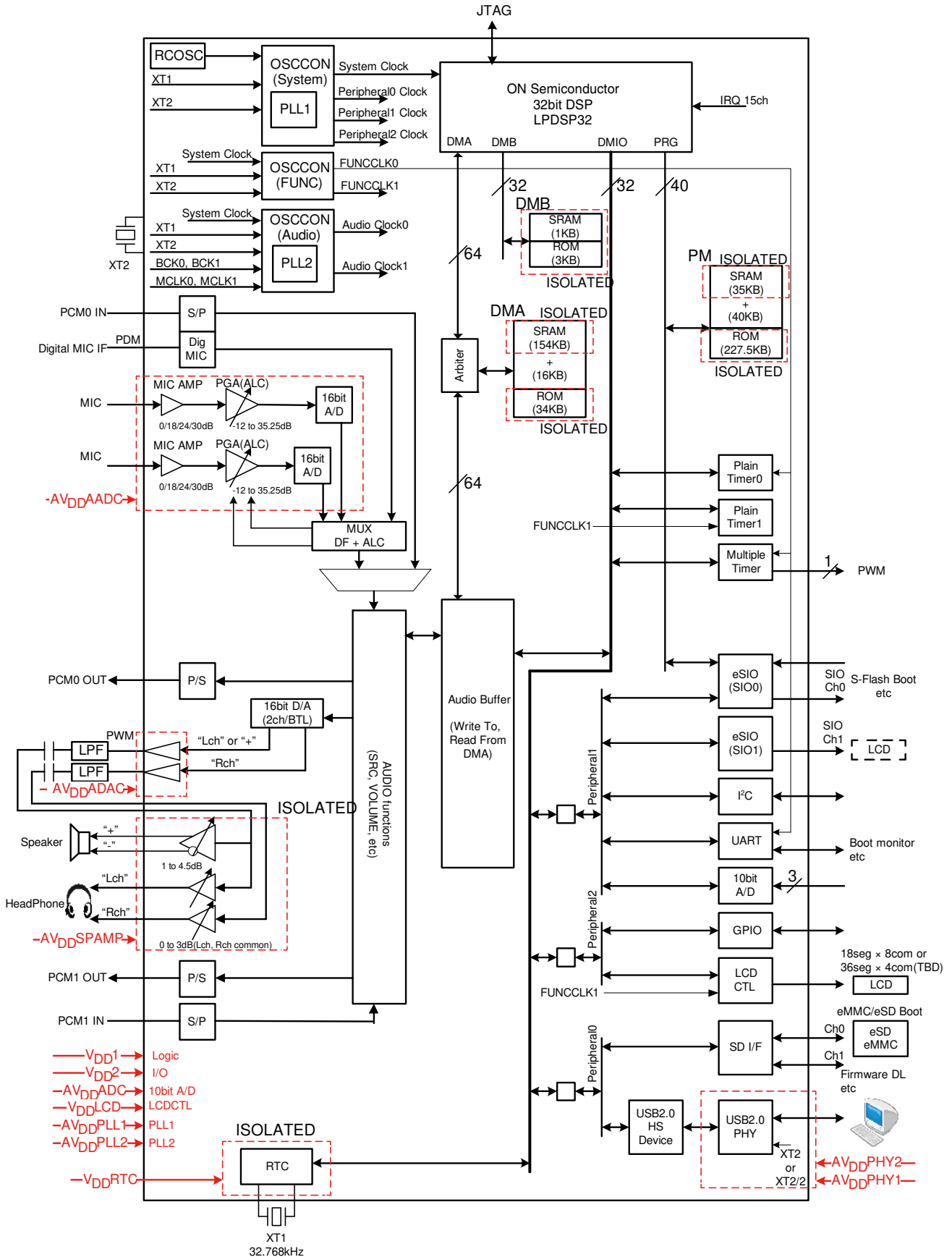

Note

- Refer to the pin assignment for port share
- ISOLATED SRAMs and ROMs described in this figure can be power off by a register, in addition to the tiny SRAMs (not described in this figure) in the SD I/F, USB2.0, SRC, 16bit D/A, DF.

LC823433TA

Pin Functions

• JTAG

Pin name	Pol.	Type	Description	Num.
JTDO/ P1C	-/ -	O/ B	JTAG test data output/ General purpose port	1
JTDI/ P1D	-/ -	I/ B	JTAG test data input/ General purpose port. The input level of the terminal JTDI is taken by rising edge of the terminal NRES. The value can be read as a register, and can be used as the operation mode setting.	1
JTMS/ P1E	-/ -	I/ B	JTAG test mode selection/ General purpose port The input level of the terminal JTMS is taken by rising edge of the terminal NRES. The value can be read as a register, and can be used as the operation mode setting.	1
JTCK/ P1F	Pos/ -	I/ B	JTAG test clock/ General purpose port	1
Total				4

• RTC

Pin name	Pol.	Type	Description	Num.
XIN32K	Pos	I	32.768kHz oscillation amplifier input (XT1)	1
XOUT32K	-	O	32.768kHz oscillation amplifier output (XT1)	1
RTCSTB	Neg	I	RTC reset input	1
(VDET)	Neg	I	There is an optional bonding as Power supply watch comparison input.	
PWRON	-	O	Main power supply ON/OFF control	1
(RTCINT)	Neg	O	There is an optional bonding as RTC interrupt output.	
LINEFIXB	Neg	I	RTC isolator cutting and the connection	1
(BACKUPB)	Neg	I	There is an optional bonding as RTC operation mode selection.	
V _{DD} RTC	-	P	RTC block power supply.	1
V _{SS} RTC	-	P	RTC ground pin.	1
Total				7

LC823433TA

• SIO (synchronous serial) interface Ch0 (eSIO)/Timer PWM output/General purpose port

Pin name	Pol.	Type	Description	Num.
SCK0/ P07	Pos/ -	B/ B	Serial I/F Ch0 clock/ General purpose port (It is possible to use it as an external interrupt input.)	1
SDO0/ P08	-/ -	O/ B	Serial I/F Ch0 data output/ General purpose port (It is possible to use it as an external interrupt input).	1
(SDO0(SIO0))	-(-)	O(B)	There is an optional bonding as serial I/F Ch0 data output (Data I/O 0 when at high speed operating).	
SDI0/ P09	-/ -	I/ B	Serial I/F Ch0 data input/ General purpose port (It is possible to use it as an external interrupt input).	1
(SDI0(SIO3))	-(-)	I(B)	There is an optional bonding as serial I/F Ch0 data input (Data I/O 3 when at high speed operating).	
TIOCA0/ P10	-/ -	B/ B	MTM Ch0 A input capture and output capture/ General purpose port	1
(V _{SS})	-	P	There is an optional bonding as V _{SS} .	
Total				4

• UART (asynchronization serial) interface/I²C interface/General purpose port

Pin name	Pol.	Type	Description	Num.
TXD/ SCL/ P12	-/ -/ -	O/ O/ B	UART transmitted serial data output/ I ² C clock output (open drain output)/ General purpose port (It is possible to use it as an external interrupt input).	1
RXD/ SDA/ P13	-/ -/ -	I/ B/ B	UART received serial data input/ I ² C data (open drain output)/ General purpose port (It is possible to use it as an external interrupt input).	1
Total				2

• Headphone control/SIO (synchronous serial) interface Ch1 (SDI, SDO)/I²C interface/General purpose port

Pin name	Pol.	Type	Description	Num.
HPDET/ SDI1/ SCL/ P1A	Pos/ -/ -/ -	I/ I/ O/ B	Headphone insertion detection/ Serial I/F Ch1 data input/ I ² C clock output (open drain output)/ General purpose port (It is possible to use it as an external interrupt input).	1
HPMUTE/ SDO1/ SDA/ P1B	Pos/ -/ -/ -	O/ O/ B/ B	Headphone mute/ Serial I/F Ch1 data output/ I ² C data (open drain output)/ General purpose port	1
Total				2

LC823433TA

- PCM interface Ch0/Digital mic interface/
SIO (synchronous serial) interface Ch1 (SCK)/General purpose port/RTC (KeyInt RTC model)

Pin name	Pol.	Type	Description	Num.
MCLK0/ DMCKO/ SCK1/ P0B	Pos/ -/ -/ -	B/ O/ B/ B	PCM Ch0 master clock/ Digital mic clock output/ Serial I/F Ch1 clock/ General purpose port (It is possible to use it as an external interrupt input).	1
KEYINT1 (NHOLD(SIO1)) (BCK0/ P0C)	- - -/ -	I O(B) B/ B	KEY interrupt1 (Notes: Operate in V _{DD} RTC and the V _{SS} RTC power supply). There is an optional bonding as serial I/F Ch0 hold output (Data I/O 1 when at high speed operating). There is an optional bonding as PCM Ch0 bit clock/ General purpose port	1
KEYINT0 (NWP(SIO2)) (LRCK0/ P0D)	- - -/ -	I O(B) B/ B	KEY interrupt0 (Notes: Operate in V _{DD} RTC and the V _{SS} RTC power supply). There is an optional bonding as serial I/F Ch0 write protect output (Data I/O 2 when high speed operating). There is an optional bonding as PCM Ch0 LR clock/ General purpose port (It is possible to use it as an external interrupt input).	1
DIN0/ DMDIN/ P0F	-/ -/ -	I/ I/ B	PCM Ch0 data input/ Digital mic data input/ General purpose port (It is possible to use it as an external interrupt input).	1
DOUT0/ P0E/ NCS (NCS)	-/ -/ Neg Neg	O/ B/ O O	PCM Ch0 data output/ General purpose port (It is possible to use it as an external interrupt input)/ CS for serial I/F Ch0 (When it boots from internal ROM and the program from SerialFlash connected to serial I/F Ch0 is loaded, it is used as CS control terminal of SerialFlash). There is an optional bonding as CS for serial I/F Ch0.	1
Total				5

LC823433TA

● SD interface Ch0/General purpose port

Pin name	Pol.	Type	Description	Num.
SDCLK0/ P14	Pos/ -	O/ B	SD card I/F Ch0 clock output/ General purpose port	1
SDCMD0/ P15	-/ -	B/ B	SD card I/F Ch0 command line/ General purpose port	1
SDAT03/ P16	-/ -	B/ B	SD card I/F Ch0 data 3/ General purpose port	1
SDAT02/ P17/ SYSCLK	-/ -/ -	B/ B/ O	SD card I/F Ch0 data 2/ General purpose port/ System Clock output (for evaluation)	1
SDAT01/ P18/ AUD0CLK	-/ -/ -	B/ B/ O	SD card I/F Ch0 data 1/ General purpose port/ Audio0 Clock output (for evaluation)	1
SDAT00/ P19/ AUD1CLK	-/ -/ -	B/ B/ O	SD card I/F Ch0 data 0/ General purpose port/ Audio1 Clock output (for evaluation)	1
Total				6

● SD interface Ch1/PCM interface Ch1/SIO (synchronous serial) interface Ch1/General purpose port

Pin name	Pol.	Type	Description	Num.
SDCLK1/ MCLK1/ P00	Pos/ Pos/ -	O/ O/ B	SD card I/F Ch1 clock output/ PCM Ch1 master clock/ General purpose port	1
SDCMD1/ LRCK1/ P02	-/ -/ -	B/ B/ B	SD card I/F Ch1 command line/ PCM Ch1 LR clock/ General purpose port	1
SDAT13/ SDO1/ P06	-/ -/ -	B/ O/ B	SD card I/F Ch1 data 3/ Serial I/F Ch1 data output/ General purpose port	1
SDAT12/ DOUT1/ P05	-/ -/ -	B/ O/ B	SD card I/F Ch1 data 2/ PCM Ch1 data output/ General purpose port	1
SDAT11/ DIN1/ P04	-/ -/ -	B/ I/ B	SD card I/F Ch1 data 1/ PCM Ch1 data input/ General purpose port	1
SDAT10/ BCK1/ P03	-/ -/ -	B/ B/ B	SD card I/F Ch1 data 0/ PCM Ch1 bit clock/ General purpose port	1
SDWP1/ SDI1/ P01	-/ -/ -	I/ I/ B	SD card I/F Ch1 write protect/ Serial I/F Ch1 data input/ General purpose port (It is possible to use it as an external interrupt input).	1
SDCD1/ SCK1/ P0A	-/ -/ -	I/ B/ B	SD card I/F Ch1 card detect/ Serial I/F Ch1 clock/ General purpose port (It is possible to use it as an external interrupt input).	1
Total				8

LC823433TA

• Oscillation amplifier and PLL

Pin name	Pol.	Type	Description	Num.
XIN2	Pos	I	Oscillation amplifier input for audio (XT2)	1
XOUT2	-	O	Oscillation amplifier output for audio (XT2)	1
VCNT1	-	O	VCO control for PLL1	1
AV _{DD} PLL1	-	P	Analog power supply for PLL1	1
AV _{SS} PLL1	-	P	Analog ground for PLL1	1
VCNT2	-	O	VCO control for PLL2	1
AV _{DD} PLL2	-	P	Analog power supply for PLL2	1
AV _{SS} PLL2	-	P	Analog ground for PLL2	1
Total				8

• 10bitA/D

Pin name	Pol.	Type	Description	Num.
AN[2:0]	-	I	ADC input	3
AV _{DD} ADC	-	P	Power supply for ADC	1
V _{SS} (AV _{SS} ADC)	-	P	Ground for ADC. It connects V _{SS} in LSI (terminal sharing). There is an optional bonding as dedicated ground AV _{SS} ADC .	1
Total				5

• Audio CODEC

Pin name	Pol.	Type	Description	Num.
AINL	-	I	Analog voice input Lch (stereo) Analog voice input (monaural).	1
AINR	-	I	Analog voice input Rch (stereo)	1
AVREF	-	O	Audio ADC reference output	1
AV _{DD} AADC	-	P	Power supply for audio ADC	1
AV _{SS} AADC	-	P	Ground for audio ADC	1
OUTML/ OUTM	-/ -	O/ O	Audio DAC PWM output (Lch for HP)/ Audio DAC PWM output (monaural for speaker)	1
OUTMR	-	O	Audio DAC PWM output (Rch for HP)	1
AV _{DD} ADAC	-	P	Power supply for audio DAC	1
AV _{SS} ADAC	-	P	Ground for audio DAC	1
HPINL/ SPKINM	-	I/ I	Headphone amplifier input (Lch) / Speaker amplifier input (monaural)	1
HPINR	-	I	Headphone amplifier input (Rch)	1
SPOUTP	-	O	AB class speaker amplifier output (+)	1
SPOUTN	-	O	AB class speaker amplifier output (-)	1
HPOUTL	-	O	Headphone amplifier output (Lch)	1
HPOUTR	-	O	Headphone amplifier output (Rch)	1
AVREFSP	-	O	AB class amplifier reference output	1
AV _{DD} SPAMP	-	P	Analog power supply for AB class amplifier	1
AV _{SS} SPAMP	-	P	Analog ground for AB class amplifier	1
Total				18

LC823433TA

• LCD Driver (4COM/8COM bonding switch)

Pin name	Pol.	Type	Description	Num.
SEG[17:0]	-	O	Segment output for LCD	18
COM[7:4]	-	O	COM [7:4], Common driver output for LCD (when 8COM is used).	4
(SEG[21:18])	-	O	There is an optional bonding as segment outputs, SEG[21:18], for the LCD(when 4COM is used).	
COM[3:0]	-	O	Common driver output for LCD. •Both 8COM and 4COM ... COM[3:0].	4
VLCD1	-	O	LCD drive voltage output 1 •When 1/3bias is used ... $2 * V_{DDLCD} / 3$. •When 1/4bias is used ... $3 * V_{DDLCD} / 4$.	1
VLCD2	-	O	LCD drive voltage output 2 •When 1/3bias is used ... $1 * V_{DDLCD} / 3$. •When 1/4bias is used ... $2 * V_{DDLCD} / 4$.	1
VLCD3	-	O	LCD drive voltage output 3 •When 1/3bias is used ... $1 * V_{DDLCD} / 3$. •When 1/4bias is used ... $1 * V_{DDLCD} / 4$.	1
V _{DDLCD}	-	P	3V power supply for LCD driver	1
Total				30

LC823433TA

• USB 2.0 HS Device/LCD Driver (bonding switch when 4COM is used)

Pin name	Pol.	Type	Description	Num.
DP	-	B	USB D+ (Device)	1
(SEG32)	-	O	There is an optional bonding as segment output 32 for LCD.	
DM	-	B	USB D- (Device)	1
(SEG33)	-	O	There is an optional bonding as segment output 33 for LCD.	
RREF	-	B	Reference resistance for USB PHY.	1
(SEG24)	-	O	There is an optional bonding as segment output 24 for LCD.	
AVDDPHY1	-	P	Analog 1.5V power supply for USB PHY. It connects V _{DD1} in LSI (terminal sharing).	1
AVSSPHY1	-	P	Analog ground for USB PHY.	1
(SEG22)	-	O	There is an optional bonding as segment output 22 for LCD.	
AVSSPHY1	-	P	Analog ground for USB PHY.	1
(SEG23)	-	O	There is an optional bonding as segment output 23 for LCD.	
AVDDPHY2	-	P	Analog 3.3V power supply for USB PHY.	1
(SEG26)	-	O	There is an optional bonding as segment output 26 for LCD.	
AVDDPHY2	-	P	Analog 3.3V power supply for USB PHY.	1
(SEG27)	-	O	There is an optional bonding as segment output 27 for LCD.	
AVDDPHY2	-	P	Analog 3.3V power supply for USB PHY.	1
(SEG31)	-	O	There is an optional bonding as segment output 31 for LCD.	
AVDDPHY2	-	P	Analog 3.3V power supply for USB PHY.	1
(SEG35)	-	O	There is an optional bonding as segment output 35 for LCD.	
AVSSPHY2	-	P	Analog ground for USB PHY.	1
(SEG25)	-	O	There is an optional bonding as segment output 25 for LCD.	
AVSSPHY2	-	P	Analog ground for USB PHY.	1
(SEG28)	-	O	There is an optional bonding as segment output 28 for LCD.	
AVSSPHY2	-	P	Analog ground for USB PHY.	1
(SEG29)	-	O	There is an optional bonding as segment output 29 for LCD.	
AVSSPHY2	-	P	Analog ground for USB PHY.	1
(SEG30)	-	O	There is an optional bonding as segment output 30 for LCD.	
AVSSPHY2	-	P	Analog ground for USB PHY.	1
(SEG34)	-	O	There is an optional bonding as segment output 34 for LCD.	
Total				15

LC823433TA

• Power supply etc.

Pin name	Pol.	Type	Description	Num.
BMODE[2:0]	-	I	Operation mode selection	3
NRES	Neg	I	External reset and GPIO•LCD driver output force input •When it is active (L input), the state of the GPIO•LCD driver is forced, and LED lighting and the LCD display is controlled until reset depends on LSI. When Low is input : GPIO = Hiz, LCD = Low Fixed (PIOFIXB). •The state of JTDI and JTMS of JTAG is taken into the internal register by rising edge of NRES (for operation mode setting).	1
V _{DD1}	-	P	Digital internal power supply There is one V _{DD1} which is also connected with AV _{DD} PHY1.	3
V _{DD2}	-	P	Digital IO power supply	3
V _{SS}	-	P	Digital ground There is one V _{SS} which is also connected with AV _{SS} ADC.	4
Total				14
Total				128

Notes : Do not open an unused digital input terminal or a digital bidirectional terminal of input state, and set Pull-up/Pull-down register in ON (only terminals with this function) or connect to digital IO power supply or digital ground.
Left open AINL, AINR, HPINL/SPKINM, and HPINR terminals if they are not used (do not fix to L or H).

Operational mode

Various boot modes etc. can be selected by switching BMODE[2:0] terminal.

BMODE2	BMODE1	BMODE0	Operational mode
0	0	0	Internal ROM boot (eMMC Physical Boot - SD interface Ch0)
0	0	1	Internal ROM boot (IPL Boot - SD interface Ch0)
0	1	0	Internal ROM boot (Partition Boot - SD interface Ch0)
0	1	1	Internal ROM boot (External Serial Flash Boot - SIO (synchronous serial) interface Ch0)
1	0	0	Liberation of the terminal for SD interface Ch0 and SIO Ch0 (SDCLK0, SDCMD0, SDAT03, SDAT02, SDAT01, SDAT00, SCK0, SDO0, SDIO, and DOUT0 (NCS) are output Hiz).
1	0	1	Internal ROM boot (Deletion Partition area and IPL user area – SD interface Ch0 and SIO external Serial Flash Ch0)
1	1	0	LSI test mode (Do not set to this mode when working actually).
1	1	1	LSI test mode (Do not set to this mode when working actually).

LC823433TA

Pin Type

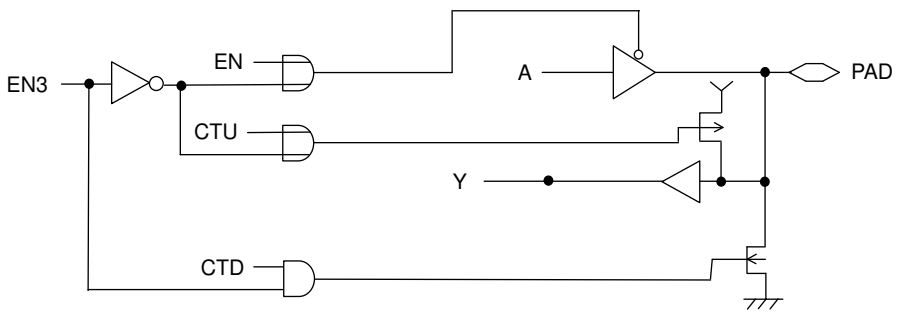
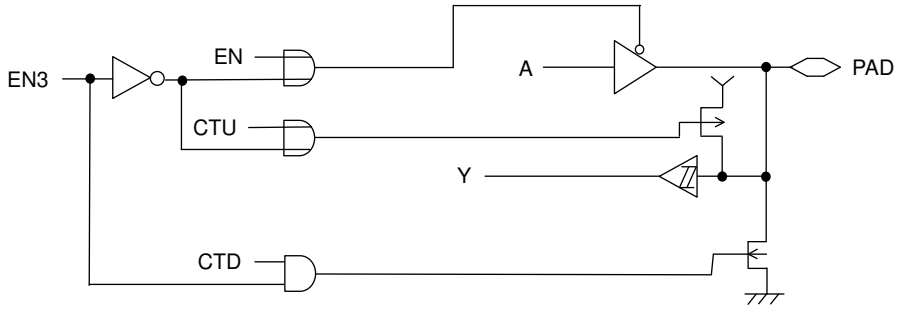
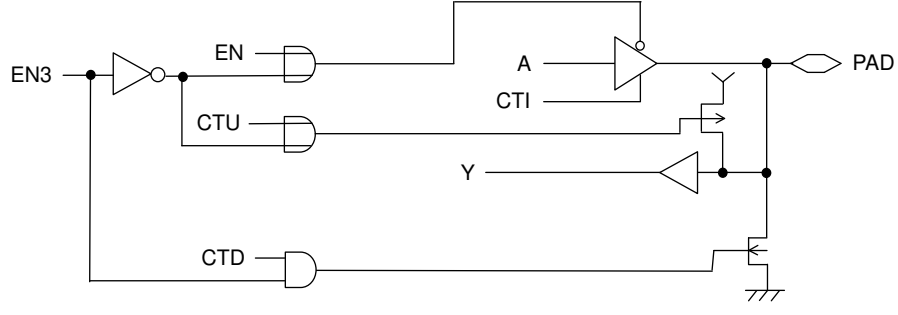
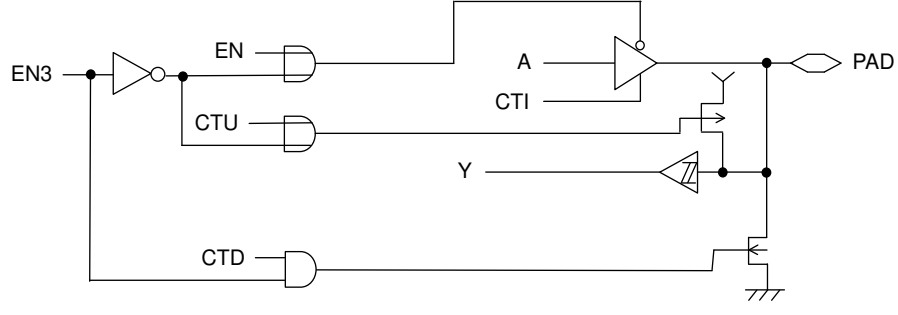
<p>3ICUD/ 3T2</p>	 <p>EN3 = 0: PAD is configured as input & Pull_up OFF, Pull_down OFF, EN3 = 1 normal</p>
<p>3ISUD/ 3T2 3ISUD/ 3T4</p>	 <p>EN3 = 0: PAD is configured as input & Pull_up OFF, Pull_down OFF, EN3 = 1 normal</p>
<p>3ICUD/ 3T4(8) 3ICUD/ 3T6(12)</p>	 <p>CTI current ability switch terminal 0: 4mA 1: 8mA/ 0: 6mA 1: 12mA EN3 = 0: PAD is configured as input & Pull_up OFF, Pull_down OFF, EN3 = 1 normal</p>
<p>3ISUD/ 3T4(8) 3ISUD/ 3T6(12)</p>	 <p>CTI current ability switch terminal 0: 4mA 1: 8mA/ 0: 6mA 1: 12mA EN3 = 0: PAD is configured as input & Pull_up OFF, Pull_down OFF, EN3 = 1 normal</p>

Continued on next page.

LC823433TA

Continued from preceding page.

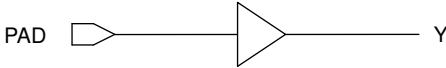
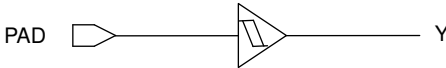
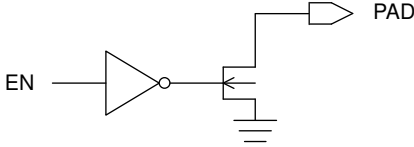
1IC	
1IS 3IS	
OD3	

ORDERING INFORMATION

Device	Package	Shipping (Qty / Packing)
LC823433TAK-2H	TQFP128 14x14 / TQFP128L (Pb-Free / Halogen Free)	450 / Tray JEDEC

ON Semiconductor and the ON logo are registered trademarks of Semiconductor Components Industries, LLC (SCILLC) or its subsidiaries in the United States and/or other countries. SCILLC owns the rights to a number of patents, trademarks, copyrights, trade secrets, and other intellectual property. A listing of SCILLC's product/patent coverage may be accessed at www.onsemi.com/site/pdf/Patent-Marking.pdf. SCILLC reserves the right to make changes without further notice to any products herein. SCILLC makes no warranty, representation or guarantee regarding the suitability of its products for any particular purpose, nor does SCILLC assume any liability arising out of the application or use of any product or circuit, and specifically disclaims any and all liability, including without limitation special, consequential or incidental damages. "Typical" parameters which may be provided in SCILLC data sheets and/or specifications can and do vary in different applications and actual performance may vary over time. All operating parameters, including "Typicals" must be validated for each customer application by customer's technical experts. SCILLC does not convey any license under its patent rights nor the rights of others. SCILLC products are not designed, intended, or authorized for use as components in systems intended for surgical implant into the body, or other applications intended to support or sustain life, or for any other application in which the failure of the SCILLC product could create a situation where personal injury or death may occur. Should Buyer purchase or use SCILLC products for any such unintended or unauthorized application, Buyer shall indemnify and hold SCILLC and its officers, employees, subsidiaries, affiliates, and distributors harmless against all claims, costs, damages, and expenses, and reasonable attorney fees arising out of, directly or indirectly, any claim of personal injury or death associated with such unintended or unauthorized use, even if such claim alleges that SCILLC was negligent regarding the design or manufacture of the part. SCILLC is an Equal Opportunity/Affirmative Action Employer. This literature is subject to all applicable copyright laws and is not for resale in any manner.