



Chipsmall Limited consists of a professional team with an average of over 10 year of expertise in the distribution of electronic components. Based in Hongkong, we have already established firm and mutual-benefit business relationships with customers from,Europe,America and south Asia,supplying obsolete and hard-to-find components to meet their specific needs.

With the principle of “Quality Parts,Customers Priority,Honest Operation,and Considerate Service”,our business mainly focus on the distribution of electronic components. Line cards we deal with include Microchip,ALPS,ROHM,Xilinx,Pulse,ON,Everlight and Freescale. Main products comprise IC,Modules,Potentiometer,IC Socket,Relay,Connector.Our parts cover such applications as commercial,industrial, and automotives areas.

We are looking forward to setting up business relationship with you and hope to provide you with the best service and solution. Let us make a better world for our industry!



## Contact us

Tel: +86-755-8981 8866 Fax: +86-755-8427 6832

Email & Skype: info@chipsmall.com Web: www.chipsmall.com

Address: A1208, Overseas Decoration Building, #122 Zhenhua RD., Futian, Shenzhen, China





**ON Semiconductor®**

<http://onsemi.com>

# LC88F83B0A

---

CMOS IC

FROM 128K byte, RAM 4096K byte on-chip

## 16-bit 1-chip Microcontroller

### Overview

The LC88F83B0A is a 16-bit microcontroller, centered around an Xstormy16 CPU, integrates on a single chip a number of hardware features such as 32-bit program counter, 16 bits  $\times$  16 general purpose register, 128K-byte flash ROM (onboard programmable), 4096-byte RAM, LCD display dedicated RAM, LCD dot matrix driver, on-chip debugging function, programmable timer, a base timer serving as a time-of-day clock, a synchronous SIO interface with automatic transmission capability, an asynchronous SIO (UART) interface, a 12-/8-bit resolution 4-channel AD converter, and a 12-source 11-vector interrupt feature.

### Features

#### ■Flash ROM

- 128K  $\times$  8bit (Table data reside in the same space.)

#### ■RAM

- 4240  $\times$  8bit
- For data 4096  $\times$  8bit
- For display 72  $\times$  16bit

#### ■LCD Display

- 64 segment  $\times$  16 common/72 segment  $\times$  8 common (1/4 bias)

\* This product is licensed from Silicon Storage Technology, Inc. (USA).

# LC88F83B0A

---

## ■ Instruction Execution Time (min)

- 31.0μs : 32.768kHz crystal used
- 15.6μs (typ) : Low speed RC oscillation (typ: 64kHz)
- 0.25μs : 4.0MHz ceramic filter oscillation
- 1.00μs (typ) : High speed RC oscillation (typ: 1MHz)

## ■ Power Supply Voltage

- 2.3V to 5.5V (Ta = -20 to 75°C) : 32.768kHz crystal used
- 2.3V to 5.5V (Ta = 0 to 60°C) : Low speed RC oscillation (typ: 64kHz)
- 2.4V to 5.5V (Ta = -20 to 75°C) : 4.0MHz ceramic filter oscillation
- 2.3V to 5.5V (Ta = 0 to 60°C) : High-speed RC oscillation (typ: 1MHz)
- 2.4V to 5.5V (Ta = -20 to 75°C) : When LCD ON

## ■ Consumption Current (3.0V):

- 10.5μA (typ)  
(Ta=25°C, crystal oscillation 32.768kHz, 1/1 dividing frequency, HALT, LCD: ON)
- 300μA (typ)  
(Ta=25°C, crystal oscillation 32.768kHz, CF 4MHz, 1/2 dividing frequency, HALT, LCD: ON)
- 2200μA (typ)  
(Ta=25°C, crystal oscillation 32.768kHz, CF 4MHz, 1/2 dividing frequency, continuous operation, LCD: ON)

## ■ Ports

- Normal withstand voltage I/O ports : 20 (P0n, P1n, P20 to P23)
- LCD (COM8/SEG0 to COM15/SEG7 pins are multiplexed with COMMON and SEGMENT)
  - LCD drive bias power supply port : 4 (VLCD1 to VLCD4)
  - Step-up capacitor port : 2 (CUP00, CUP01)
- 16 common mode
  - Segment output : 64 (SEG8 to SEG71)
  - Common output : 16 (COM0 to COM15)
- 8 common mode
  - Segment output : 72 (SEG0 to SEG71)
  - Common output : 8 (COM0 to COM7)
- Oscillation pins : 4 (XT1, XT2, CF1, CF2)
- Reset pin : 1 (RESB)
- Test pin : 1 (TST)
- LCD port power pins : 2 (LCDVSS0, LCDVSS1)
- Power pins : 2 (VDD, VSS)

## ■ LCD

- LCD power supply : Capacitor step-up type
- Number of dots : 1024 (64 segments × 16 commons) / 576 (72 segments × 8 commons)
- Contrast : Adjustable in 16 steps
- LCD frame frequency : Selectable from 4 types

## ■ Timers

- Timer 0: 16-bit timer that supports PWM/toggle outputs
  - 1) With 5-bit prescaler
  - 2) 8-bit PWM  $\times$  2/8-bit timer + 8-bit PWM mode selectable
  - 3) Clock source selectable from system clock, OSC0, OSC1, and internal RC oscillator
- Timer 1: 16-bit timer with capture registers
  - 1) With 5-bit prescaler
  - 2) May be divided into 2 channels of 8-bit timer
  - 3) Clock source selectable from system clock, OSC0, OSC1, and internal RC oscillator
- Timer 3: 16-bit timer that supports PWM/toggle outputs
  - 1) With 8-bit prescaler
  - 2) 8-bit timer  $\times$  2ch/8-bit timer + 8-bit PWM mode selectable
  - 3) Clock source selectable from system clock, OSC0, OSC1, and internal RC oscillator
- Timer 4: 16-bit timer that supports toggle outputs
  - 1) Clock source selectable from system clock and prescaler 0
- Timer 5: 16-bit timer that supports toggle outputs
  - 1) Clock source selectable from system clock and prescaler 0
- Base timer
  - 1) Clock may be selected from OSC0 (32.768kHz crystal oscillator) and frequency-divided output of system clock.
  - 2) Interrupts can be generated in 7 timing schemes.

## ■ Watchdog Timer

- 1) Driven by the base timer + internal watchdog timer dedicated counter.
- 2) Interrupt or reset mode selectable

## ■ SIO0: 8-bit synchronous SIO

- 1) LSB first/MSB first mode selectable
- 2) It is possible to communicate with 8 bits or less. (1 to 8 bits specifiable in 1-bit units)
- 3) Built-in 8-bit baudrate generator (transfer clock cycle 4 tCYC to 512 tCYC)
- 4) Automatic continuous data transmission (9 to 32768 bits specifiable in 1-bit units)
- 5) Interval function (interval time: 0 to 64 SIOCLKs specifiable in 1 SIOCLK units)
- 6) Wakeup function

## ■ UART2: Asynchronous SIO

- 1) Full duplex transmission
- 2) Start bit 1, data bit 8 (LSB first), stop bit 1
- 3) Parity bit: None/even parity/odd parity
- 4) Transfer rate: 8 to 4096 tCYC
- 5) Baudrate source clock: systemclock/OSC0/OSC1
- 6) Wakeup function

## ■ AD converter: 12bit $\times$ 4 channels

- 1) 12-/8-bit resolution selectable
- 2) Analog input: 4 channels
- 3) Comparator mode
- 4) Automatic reference voltage generation

## ■Interrupts

- 12 sources, 11 vector addresses

- 1) Provides three levels of multiplex interrupt control. Any interrupt requests of the level equal to or lower than the current interrupt are not accepted.
- 2) When interrupt requests to two or more vector addresses occur at the same time, the interrupt of the highest level takes precedence over the other interrupts. For interrupts of the same level, the interrupt into the smallest vector address takes precedence.

No.	Vector Address	Interrupt Source
1	08000H	WATCHDOGTIMER
2	08004H	BASETIMER
3	08008H	TIMER0
4	08018H	SIO0
5	0801CH	TIMER1
6	08020H	UART2
7	08024H	TIMER3
8	08028H	TIMER4
9	0802CH	TIMER5
10	08030H	ADC
11	0803CH	P00 to P05 SEG71 to SEG64

- The priority level can be specified by three levels.
- Of interrupts of the same level, the one with the smallest vector address takes precedence.

## ■Subroutine Stack Levels

- Max- whole RAM area (Stack is set in RAM)

## ■Oscillation Circuits

- OSC1: For system clock  
ceramic oscillation with external CGC, CDC or RC oscillation (external RCR1)
  - OSC0: For low-speed system clock, base timer count, for LCD display  
32kHz crystal oscillation with external CGX, CDX or RC oscillation (external RCR0)
  - Internal oscillation circuit: Internal RC
- \* Depends on control resistor for each oscillator operation and stop.  
Initial setting - External oscillation stop, internal RC oscillation operation

# LC88F83B0A

## ■ Standby Function

- HALT mode: Halts instruction execution while allowing the peripheral circuits to continue operation.
  - 1) Oscillation is not halted automatically.
  - 2) Released by a system reset or occurrence of an interrupt.
- HOLD mode: Suspends instruction execution and the operation of the peripheral circuits.
  - 1) OSC1, internal RC and X'tal oscillators automatically stop operation.
  - 2) There are the following methods of resetting the HOLD.
    - (1) Setting the reset pin to the low level
    - (2) Having an interrupt source established in the SIO0
    - (3) Having an interrupt source established in the UART2
    - (4) Having an interrupt source established in the P00 to P05
    - (5) Having an interrupt source established in the SEG71 to SEG64
- X'tal HOLD mode: Suspends instruction execution and the operation of the peripheral circuits except using OSC0.
  - 1) The OSC1 and internal RC oscillators automatically stop operation.
  - 2) The state of OSC0 oscillation established when the X'tal HOLD mode is entered is retained.
  - 3) There are the following methods of resetting the X'tal HOLD mode.
    - (1) Setting the reset pin to the low level
    - (2) Having an interrupt source established in the base timer circuit
    - (3) Having an interrupt source established in the timers 0, 1, 3, 4, 5
    - (4) Having an interrupt source established in the SIO0
    - (5) Having an interrupt source established in the UART2
    - (6) Having an interrupt source established in the P00 to P05
    - (7) Having an interrupt source established in the SEG71 to SEG64

## ■ On-chip debugger

- Supports software debugging with the IC mounted on the target board.
- Supports tracing, realtime monitoring, and breakpoint setting.
- Single-wire communication

## ■ Package Form

- TQFP120(14×14): Lead-free type

## ■ Development Tools

- On-chip debugger : EOCUIF1 + LC88F83B0A
- Programming boards :

## Package Dimensions

unit : mm (typ)

3257A

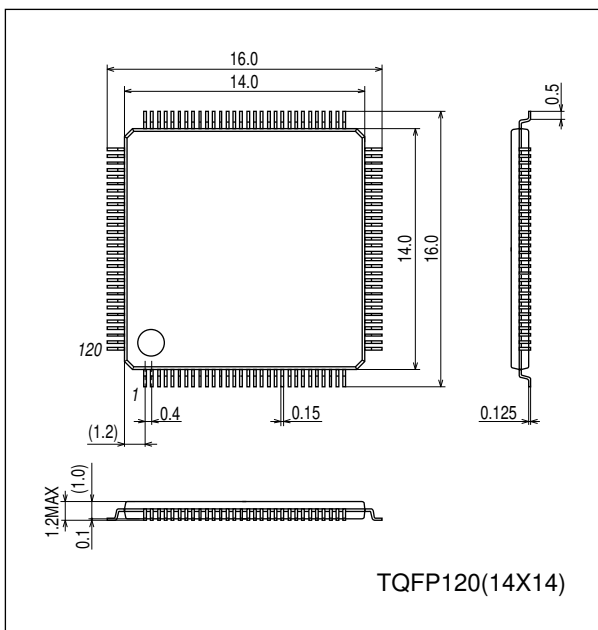

# LC88F83B0A

## Pad Assignment

- Chip size (X × Y) : 3.40mm × 3.19mm
- Pad size : 59μm
- Pad pitch : 80μm
- Chip thickness : 280μm ± 20μm

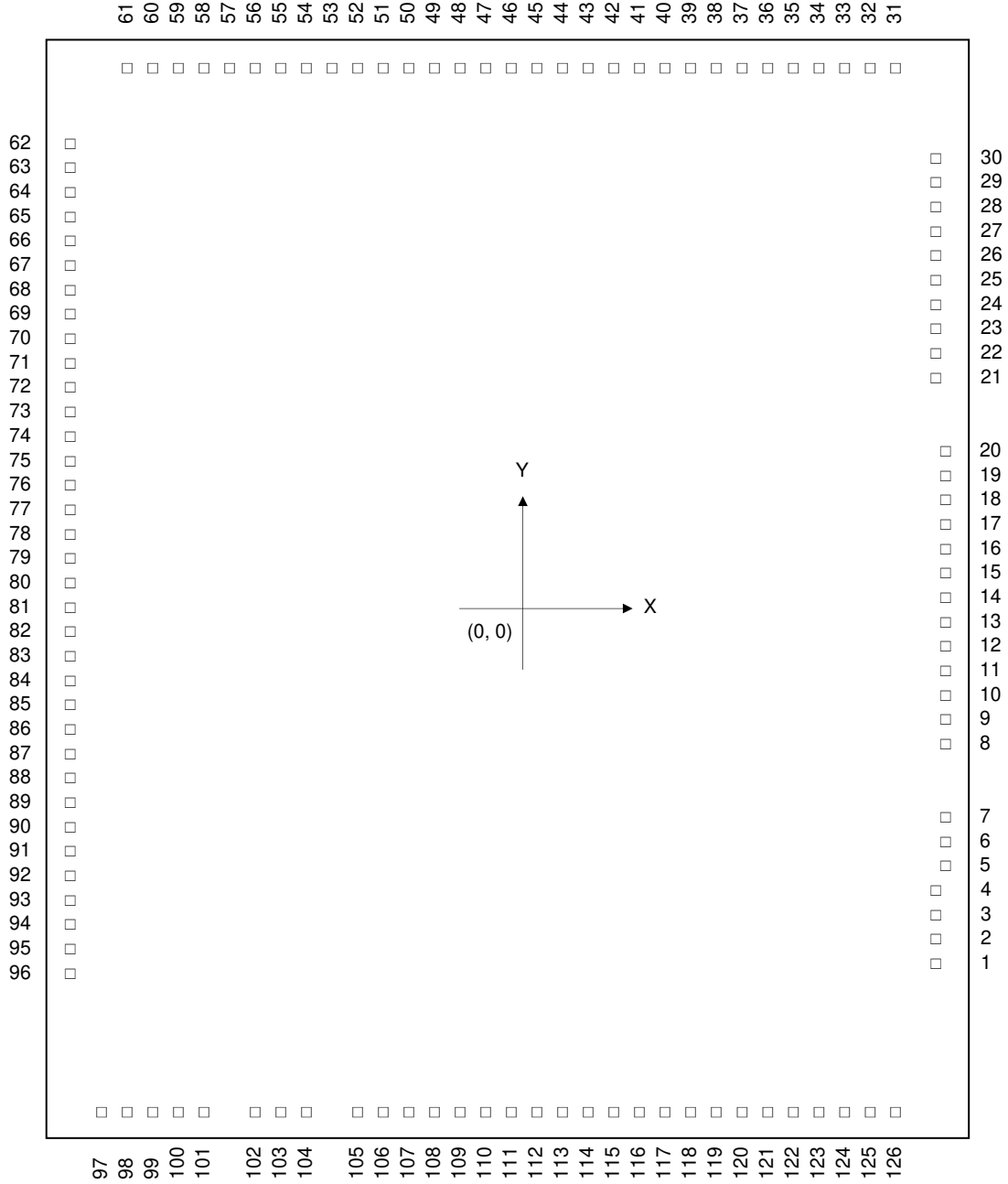

Note: Pin numbers assigned to a package differ from pad numbers assigned to a chip.  
 Numbers in the above figure show the pad numbers of the chip.

# LC88F83B0A

## Pad Coordinates Table

Pad No.	Pin Name	Coordinates		Pad No.	Pin Name	Coordinates	
		X $\mu$ m	Y $\mu$ m			X $\mu$ m	Y $\mu$ m
1	P20	1567.4	-1308	48	SEG29	-192	1462.4
2	P21	1567.4	-1228	49	SEG28	-272	1462.4
3	P22	1567.4	-1147	50	SEG27	-352	1462.4
4	P23	1567.4	-1067	51	SEG26	-432	1462.4
5	SEG71	1606.99	-951.8	52	SEG25	-512	1462.4
6	SEG70	1606.99	-863.6	53	SEG24	-592	1462.4
7	SEG69	1606.99	-775.4	54	SEG23	-672	1462.4
8	SEG68	1606.99	-606.8	55	SEG22	-752	1462.4
9	SEG67	1606.99	-518.6	56	SEG21	-832	1462.4
10	SEG66	1606.99	-430.4	57	SEG20	-912	1462.4
11	SEG65	1606.99	-342.2	58	SEG19	-992	1462.4
12	SEG64	1606.99	-254	59	SEG18	-1072	1462.4
13	SEG63	1606.99	-165.8	60	SEG17	-1152	1462.4
14	SEG62	1606.99	-77.6	61	SEG16	-1232	1462.4
15	SEG61	1606.99	10.6	62	SEG15	-1567.4	1335
16	SEG60	1606.99	98.8	63	SEG14	-1567.4	1255
17	SEG59	1606.99	187	64	SEG13	-1567.4	1175
18	SEG58	1606.99	275.2	65	SEG12	-1567.4	1095
19	SEG57	1606.99	363.4	66	SEG11	-1567.4	1015
20	SEG56	1606.99	451.6	67	SEG10	-1567.4	935
21	SEG55	1567.4	573	68	SEG9	-1567.4	855
22	SEG54	1567.4	653	69	SEG8	-1567.4	775
23	SEG53	1567.4	733	70	-	-	-
24	SEG52	1567.4	813	71	COM15/SEG7	-1567.4	615
25	SEG51	1567.4	893	72	-	-	-
26	SEG50	1567.4	973	73	COM14/SEG6	-1567.4	455
27	SEG49	1567.4	1053	74	-	-	-
28	SEG48	1567.4	1133	75	COM13/SEG5	-1567.4	295
29	SEG47	1567.4	1213	76	-	-	-
30	SEG46	1567.4	1293	77	COM12/SEG4	-1567.4	135
31	LCDV <sub>SS1</sub>	1190	1462.4	78	-	-	-
32	SEG45	1088	1462.4	79	COM11/SEG3	-1567.4	-25
33	SEG44	1008	1462.4	80	-	-	-
34	SEG43	928	1462.4	81	COM10/SEG2	-1567.4	-185
35	SEG42	848	1462.4	82	-	-	-
36	SEG41	768	1462.4	83	COM9/SEG1	-1567.4	-345
37	SEG40	688	1462.4	84	-	-	-
38	SEG39	608	1462.4	85	COM8/SEG0	-1567.4	-505
39	SEG38	528	1462.4	86	COM7	-1567.4	-585
40	SEG37	448	1462.4	87	COM6	-1567.4	-665
41	SEG36	368	1462.4	88	COM5	-1567.4	-745
42	SEG35	288	1462.4	89	COM4	-1567.4	-825
43	SEG34	208	1462.4	90	COM3	-1567.4	-905
44	SEG33	128	1462.4	91	COM2	-1567.4	-985
45	SEG32	48	1462.4	92	COM1	-1567.4	-1065
46	SEG31	-32	1462.4	93	COM0	-1567.4	-1145
47	SEG30	-112	1462.4	94	LCDV <sub>SS0</sub>	-1567.4	-1240

Continued on next page.



# LC88F83B0A

Continued from preceding page.

Pad No.	Pin Name	Coordinates		Pad No.	Pin Name	Coordinates	
		X $\mu$ m	Y $\mu$ m			X $\mu$ m	Y $\mu$ m
95	CUP00	-1567.4	-1335.8	111	P00	205	-1462.4
96	CUP01	-1567.4	-1415.8	112	P01	285	-1462.4
97	V <sub>LCD4</sub>	-1295.45	-1462.4	113	P02	365	-1462.4
98	V <sub>LCD3</sub>	-1215.45	-1462.4	114	P03	445	-1462.4
99	V <sub>LCD2</sub>	-1130.8	-1462.4	115	P04	525	-1462.4
100	V <sub>LCD1</sub>	-1050.8	-1462.4	116	P05	605	-1462.4
101	TST	-965	-1462.4	117	P06	685	-1462.4
102	XT2	-723	-1462.4	118	P07	765	-1462.4
103	XT1	-643	-1462.4	119	P10	845	-1462.4
104	RESB	-563	-1462.4	120	P11	925	-1462.4
105	V <sub>DD</sub>	-383.5	-1462.4	121	P12	1005	-1462.4
106		-272.5	-1462.4	122	P13	1085	-1462.4
107	CF1	-172	-1462.4	123	P14	1165	-1462.4
108	CF2	-92	-1462.4	124	P15	1245	-1462.4
109	V <sub>SS</sub>	3	-1462.4	125	P16	1325	-1462.4
110		108	-1462.4	126	P17	1405	-1462.4

Note:

- Pad coordinates shown in above table are referenced at the center of the IC-chip as an origin.
- There are two pads for each V<sub>DD</sub> and V<sub>SS</sub>, and each set of pads needs double-bonding.

## Pin Assignment

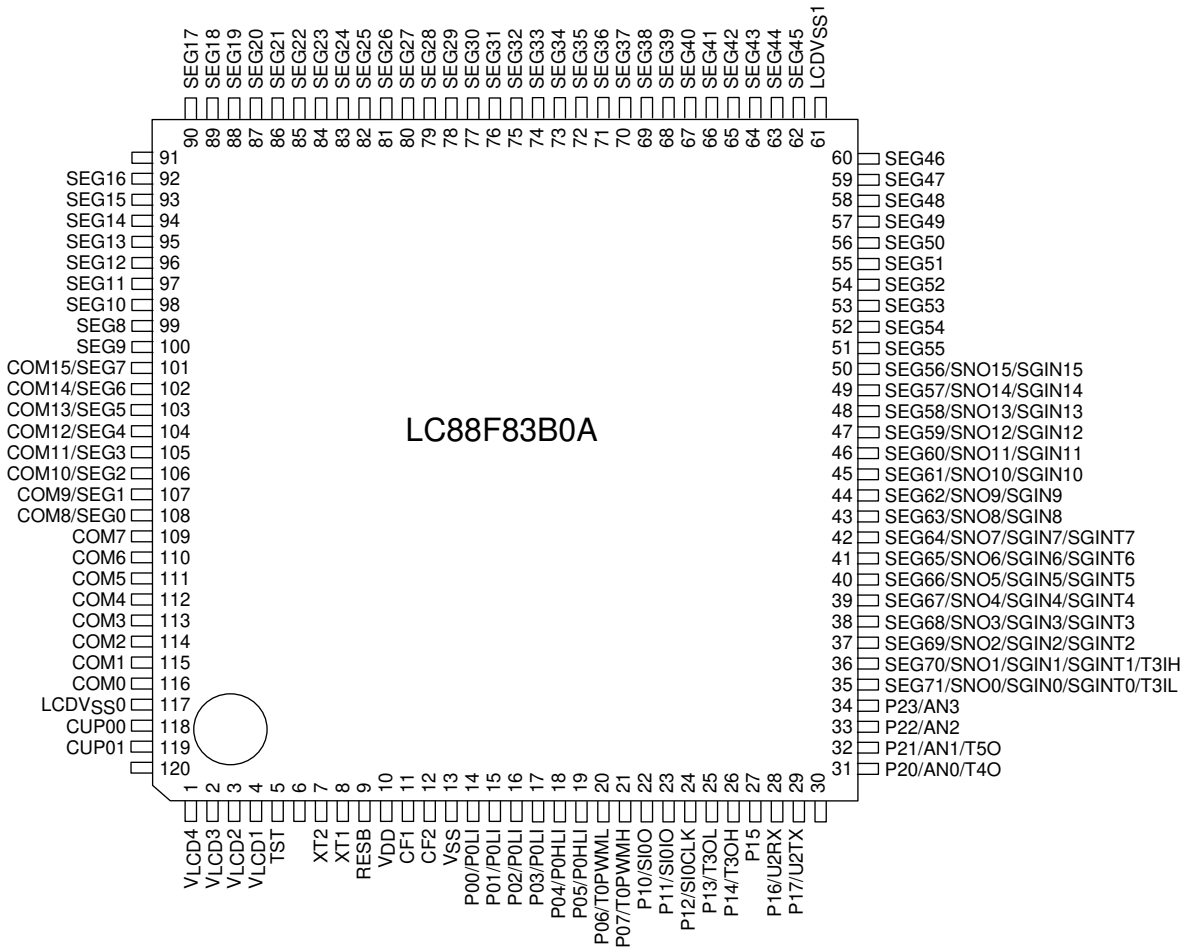

Top view

TQFP120(14×14) “Lead-free Type”

# LC88F83B0A

Pin No.	Name	Pin No.	Name	Pin No.	Name	Pin No.	Name
1	V <sub>LCD4</sub>	31	P20/AN0/T4O	61	LCDV <sub>SS1</sub>	91	
2	V <sub>LCD3</sub>	32	P21/AN1/T5O	62	SEG45	92	SEG16
3	V <sub>LCD2</sub>	33	P22/AN2	63	SEG44	93	SEG15
4	V <sub>LCD1</sub>	34	P23/AN3	64	SEG43	94	SEG14
5	TST	35	SEG71/SNO0 /SGIN0/SGINT0 /T3IL	65	SEG42	95	SEG13
6		36	SEG70/SNO1 /SGIN1/SGINT1 /T3IH	66	SEG41	96	SEG12
7	XT2	37	SEG69/SNO2 /SGIN2/SGINT2	67	SEG40	97	SEG11
8	XT1	38	SEG68/SNO3 /SGIN3/SGINT3	68	SEG39	98	SEG10
9	RESB	39	SEG67/SNO4 /SGIN4/SGINT4	69	SEG38	99	SEG9
10	V <sub>DD</sub>	40	SEG66/SNO5 /SGIN5/SGINT5	70	SEG37	100	SEG8
11	CF1	41	SEG65/SNO6 /SGIN6/SGINT6	71	SEG36	101	COM15/SEG7
12	CF2	42	SEG64/SNO7 /SGIN7/SGINT7	72	SEG35	102	COM14/SEG6
13	V <sub>SS</sub>	43	SEG63/SNO8 /SGIN8	73	SEG34	103	COM13/SEG5
14	P00/P0LI	44	SEG62/SNO9 /SGIN9	74	SEG33	104	COM12/SEG4
15	P01/P0LI	45	SEG61/SNO10 /SGIN10	75	SEG32	105	COM11/SEG3
16	P02/P0LI	46	SEG60/SNO11 /SGIN11	76	SEG31	106	COM10/SEG2
17	P03/P0LI	47	SEG59/SNO12 /SGIN12	77	SEG30	107	COM9/SEG1
18	P04/P0HLI	48	SEG58/SNO13 /SGIN13	78	SEG29	108	COM8/SEG0
19	P05/P0HLI	49	SEG57/SNO14 /SGIN14	79	SEG28	109	COM7
20	P06/T0PWML	50	SEG56/SNO15 /SGIN15	80	SEG27	110	COM6
21	P07/T0PWMH	51	SEG55	81	SEG26	111	COM5
22	P10/SI0O	52	SEG54	82	SEG25	112	COM4
23	P11/SI0IO	53	SEG53	83	SEG24	113	COM3
24	P12/SI0CLK	54	SEG52	84	SEG23	114	COM2
25	P13/T3OL	55	SEG51	85	SEG22	115	COM1
26	P14/T3OH	56	SEG50	86	SEG21	116	COM0
27	P15	57	SEG49	87	SEG20	117	LCDV <sub>SS0</sub>
28	P16/U2RX	58	SEG48	88	SEG19	118	CUP00
29	P17/U2TX	59	SEG47	89	SEG18	119	CUP01
30		60	SEG46	90	SEG17	120	

# LC88F83B0A

## System Block Diagram

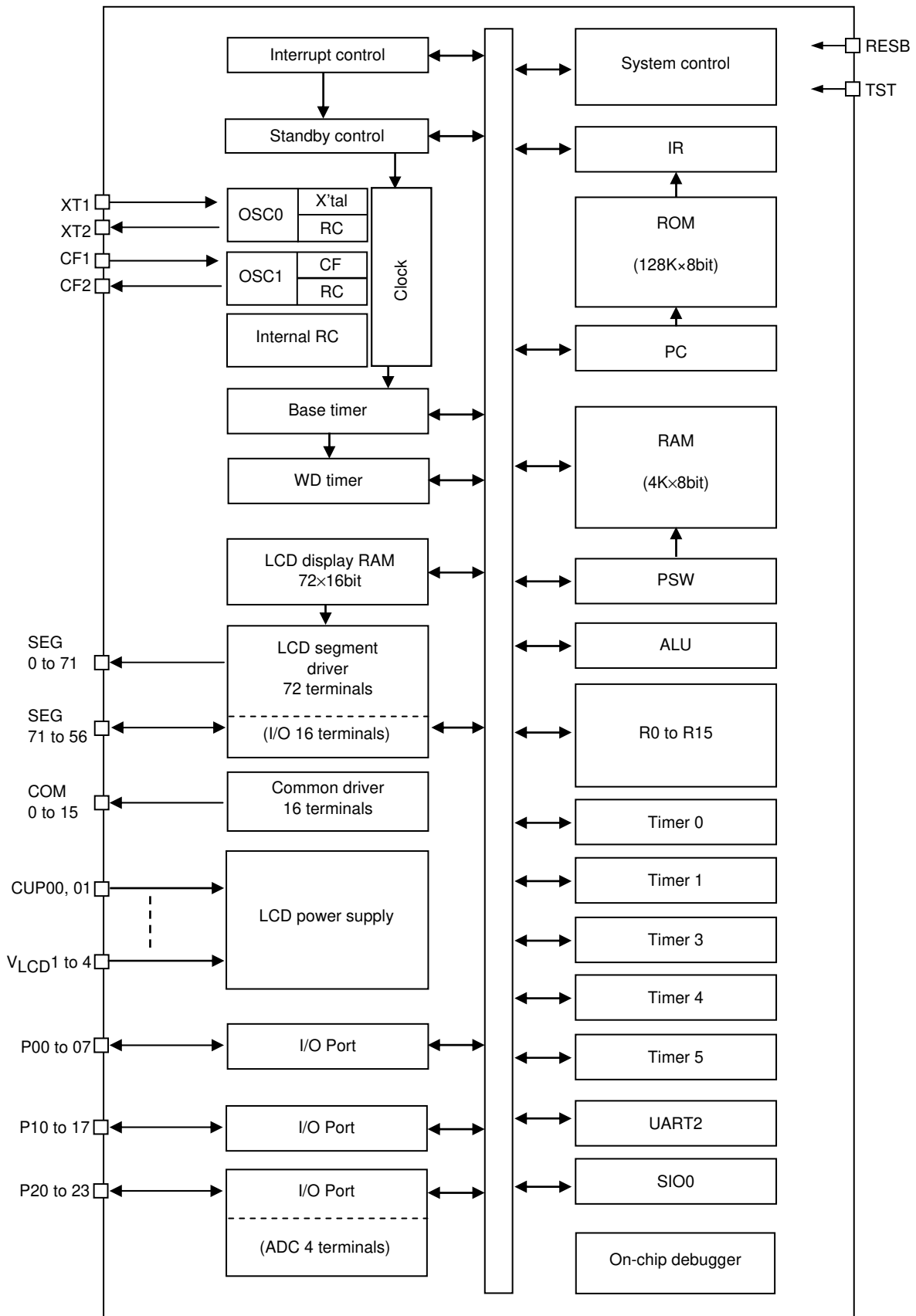

# LC88F83B0A

## Pin Description

Pin Name	I/O	Description
V <sub>DD</sub>	-	+ power supply pin
V <sub>SS</sub>	-	- power supply pin
V <sub>LCD1</sub> to 4	-	LCD bias power port (capacitor connection port)
LCDV <sub>SS0</sub> , LCDV <sub>SS1</sub>	-	LCD power supply pin
CUP00, 01	-	Switching pin for generating LCD driving voltage Connect capacitor between both ports.
OSC0	XT1	I
	XT2	O
		Oscillator circuit for system clock (low speed) <ul style="list-style-type: none"> <li>• 32.768kHz crystal oscillator and capacitor for oscillation connection</li> <li>• XT1: Resistor connection for RC oscillation (RC model)</li> </ul>
OSC1	CF1	I
	CF2	O
		Oscillator circuit for system clock (high speed) <ul style="list-style-type: none"> <li>• Ceramic oscillator and capacitor for oscillator connection</li> <li>• CF1: Resistance connection for RC oscillator (RC model)</li> </ul>
PORT 0 P00 to P07	I/O	<ul style="list-style-type: none"> <li>• 8-bit I/O port</li> <li>• I/O specifiable in 1-bit units</li> <li>• Shared pins P00 to P05 : Interrupt function P06: Timer 0 PWML output P07: Timer 0 PWMH output</li> </ul>
PORT 1 P10 to P17	I/O	<ul style="list-style-type: none"> <li>• 8-bit I/O port</li> <li>• I/O specifiable in 1-bit units</li> <li>• Shared pins P10: SIO0 data output P11: SIO0 data input/Bus I/O P12: SIO0 Clock I/O P13: Timer 3 PWML output P14: Timer 3 PWMH output P16: UART 2 receive P17: UART 2 send</li> </ul>
PORT 2 P20 to P23	I/O	<ul style="list-style-type: none"> <li>• 4-bit I/O port</li> <li>• I/O specifiable in 1-bit units P20 to P23: AD converter input ports (AN0 to AN3)</li> <li>• Shared pins P20: Timer 4 output P21: Timer 5 output</li> </ul>
COM0 to COM7	O	• LCD common output port
COM8/SEG0 to COM15/SEG7	O	• LCD common output port/segment output port common output/segment output is switched according to the register.
SEG8 to SEG55	O	• LCD segment output port
SEG56 to SEG71	I/O	<ul style="list-style-type: none"> <li>• LCD segment output port</li> <li>• SEG71 to SEG56: General purpose Nch OD output/General purpose input SEG71 to SEG56 can switch LCD output, a general-purpose Nch OD output, and a general-purpose input (every 4 bits).</li> <li>• SEG71 to SEG64: Interrupt function (every 4 bits) Selecting sampling frequency for chattering removal (every 4 bits) Level/edge selection (every 4 bits) Hi/Low level or rise/fall selection (every 1 bit)</li> <li>• SEG71 to SEG70: Timer 3 external input</li> </ul>
RESB	I	<ul style="list-style-type: none"> <li>• Input terminal for system initialization It operates reset by the "LOW" input. with pull-up resistor</li> </ul>
TST	I/O	<ul style="list-style-type: none"> <li>• TEST pin</li> <li>• On-chip debugger communication terminal Used with pull-down or V<sub>SS</sub> *Connect 100kΩ between this pin and V<sub>SS</sub> when on-chip debugger is used.</li> </ul>

# LC88F83B0A

## Application circuit

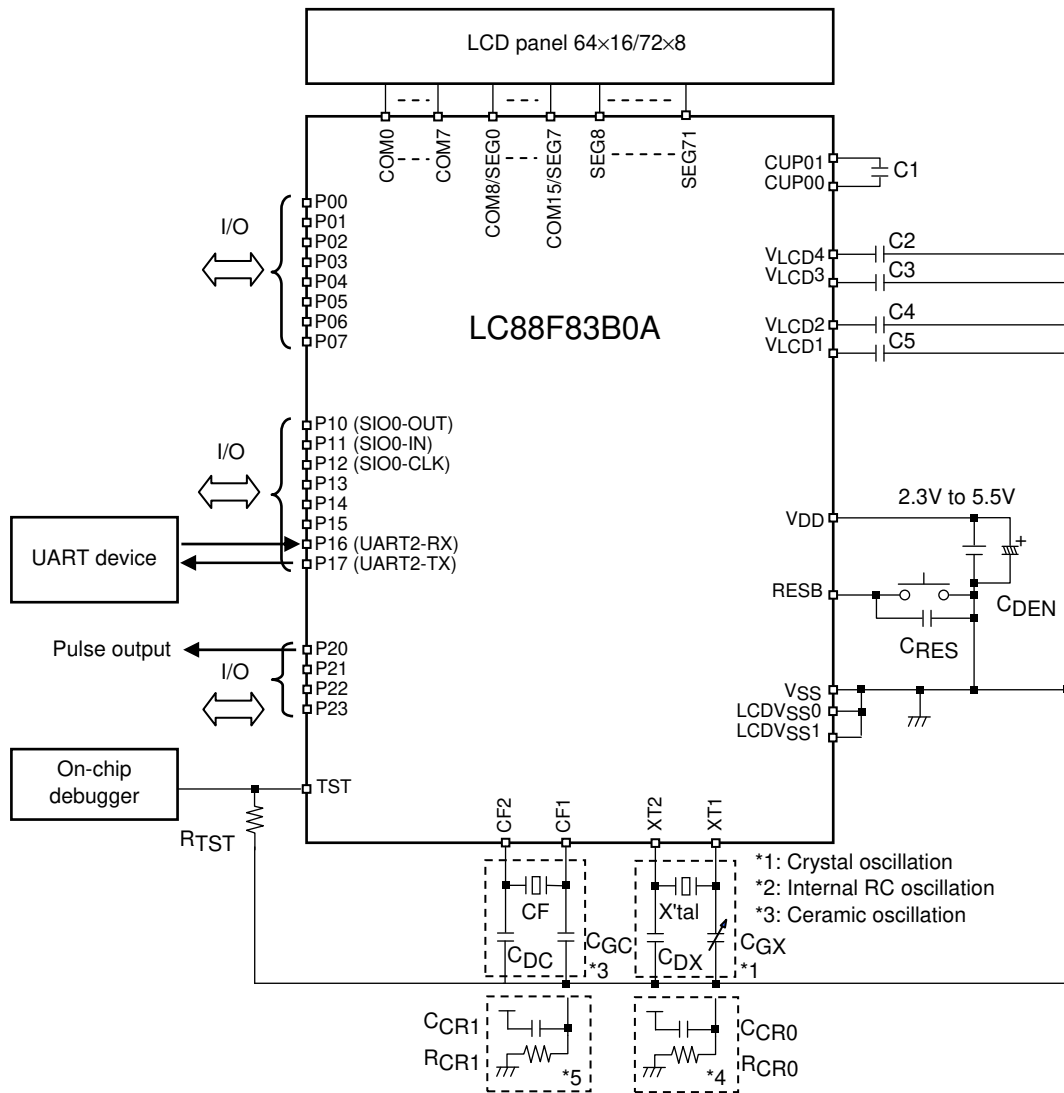

X'tal	Crystal oscillator
CGX	Trimmer capacitor
CDX	Capacitance for X'tal
RCR0	Resistor for low-speed oscillation *4: RC oscillation specification
CCR0	Capacitor for low-speed oscillation *4: RC oscillation specification (**1)
(**1)	0.1μF capacitor is recommended when using XT1/XT2 as a system clock.
CF	Ceramic oscillator
CGC	Capacitance for CF
CDC	Capacitance for CF
RCR1	Resistor for high-speed oscillation *5: RC oscillation specification
CCR1	Capacitor for high-speed oscillation *5: RC oscillation specification
C1 to C5	Capacitor
CDEN	Electrolytic capacitor
CRES	Capacitance for RESB
RTST	Resistor when on-chip debugger is used

# LC88F83B0A

## Absolute Maximum Ratings at Ta = 25°C, VSS = LCDVSS0 = LCDVSS1 = 0V

Parameter	Symbol	Pin/Remarks	Conditions	Specification				unit
				V <sub>DD</sub> [V]	min	typ	max	
Maximum supply voltage	V <sub>DD</sub> max	V <sub>DD</sub>	V <sub>DD</sub>		-0.3		+6.5	V
LCD supply voltage	V <sub>LCD</sub> max	V <sub>LCD2</sub> to V <sub>LCD4</sub>	V <sub>DD</sub>		-0.3		+6.5	
LCD maximum supply voltage	LCD max	SEG0 to SEG71 COM0 to COM15	V <sub>DD</sub> , V <sub>LCD4</sub>		-0.3		+6.5	
Input voltage	V <sub>I</sub> (1)	RESB, XT1, CF1			-0.3		V <sub>DD</sub> +0.3	
Input/output voltage	V <sub>IO</sub> (1)	PORT 0, 1, 2 SEG71 to SEG56			-0.3		V <sub>DD</sub> +0.3	
High level output current	Peak output current	IOPH(1)	PORT0, 2	CMOS output selected Current at each pin		-5		mA
		IOPH(2)	PORT1	CMOS output selected Current at each pin		-14		
	Mean output current (Note 1-1)	IOMH(1)	PORT0, 2	CMOS output selected Current at each pin		-3		
		IOMH(2)	PORT1	CMOS output selected Current at each pin		-9		
	Total output current	ΣIOAH(1)	PORT0, 2	Total of all pins		22.5		
		ΣIOAH(2)	PORT1	Total of all pins		25		
ΣIOAH(3)		PORT 0, 1, 2	Total of all pins		47.5			
Low level output current	Peak output current	IOPL(1)	PORT0, 2	Current at each pin			13	
		IOPL(2)	PORT1	Current at each pin			17	
	Mean output current (Note 1-1)	IOML(1)	PORT0, 2	Current at each pin			7.5	
		IOML(2)	PORT1	Current at each pin			10.5	
	Total output current	ΣIOAL(1)	PORT0, 2	Total of all pins			35	
		ΣIOAL(2)	PORT1	Total of all pins			60	
ΣIOAL(3)		PORT 0, 1, 2	Total of all pins			80		
Allowable power dissipation	Pd max	TQFP120(14×14)	Ta=-20 to +75°C			250	mW	
Operating ambient temperature	Topg				-20		75	°C
Storage ambient temperature	Tstg				-65		125	

Note 1-1: The mean output current is a mean value measured over 100ms.

Note: We assume that the measurements for the allowable operating ranges and electrical characteristics described in this document are performed with the chip mounted in a package.

Although this product is shipped in chip form, the characteristic values listed in this document are measured with this IC mounted on a Our designated package at operating ambient temperature range of -20°C to +70°C.

The specifications of this product in package form or in chip forms are basically identical, however, the characteristics of the product in chip form may vary depending on the board on which the product is mounted, the bonding pressure, and the type of mold resin used.

Stresses exceeding Maximum Ratings may damage the device. Maximum Ratings are stress ratings only. Functional operation above the Recommended Operating Conditions is not implied. Extended exposure to stresses above the Recommended Operating Conditions may affect device reliability.

## LC88F83B0A

**Allowable Operating Conditions** at  $T_a = -20^{\circ}\text{C}$  to  $+75^{\circ}\text{C}$ ,  $V_{SS} = \text{LCDV}_{SS0} = \text{LCDV}_{SS1} = 0\text{V}$

Parameter	Symbol	Pin /Remarks	Conditions	Ratings				unit
				$V_{DD}[\text{V}]$	min	typ	max	
Operating supply voltage (Note2-1)	$V_{DD}(1)$	$V_{DD}$	$0.238\mu\text{s} \leq t_{CYC} \leq 100\mu\text{s}$		2.6		5.5	V
			$0.476\mu\text{s} \leq t_{CYC} \leq 100\mu\text{s}$		2.4		5.5	
			$0.909\mu\text{s} \leq t_{CYC} \leq 100\mu\text{s}$		2.3		5.5	
LCD drive voltage	$V_{LCD}(1)$	$V_{LCD2}$ to $V_{LCD4}$					5.5	
Memory sustaining supply voltage	VHD	$V_{DD}$	RAM and register contents sustained in HOLD mode.		2.0		5.5	
High level input voltage	$V_{IH}(1)$	Port 0, 1	Output disabled		$0.30V_{DD} + 0.70$		$V_{DD}$	
	$V_{IH}(2)$	RESB			$0.75V_{DD}$		$V_{DD}$	
Low level input voltage	$V_{IL}(1)$	Port 0, 1	Output disabled		$V_{SS}$		$0.10V_{DD} + 0.40$	
	$V_{IL}(2)$	RESB			$V_{SS}$		$0.25V_{DD}$	
Oscillating frequency range (Note2-3)	FOSC0	XT1, XT2	Crystal oscillation	2.3 to 5.5		32.768		kHz
			Low speed RC oscillation (Note2-2)	2.3 to 5.5	30		80	
	FOSC1	CF1, CF2	Ceramic oscillation	2.4 to 5.5	400		4200	
			High-speed RC oscillation (Note2-2)	2.4 to 5.5	400		4200	
	FINTRC		Internal RC oscillation				1000	

Note2-1:  $V_{DD}$  must be held greater than or equal to 2.7V in the flash ROM onboard programming mode.

Note2-2:  $T_a = 0^{\circ}\text{C}$  to  $60^{\circ}\text{C}$

Note2-3: The parts value of oscillation circuit is shown in table 1 and table 2.

# LC88F83B0A

## Electrical Characteristics at Ta = -20°C to +75°C, V<sub>SS</sub> = LCDV<sub>SS0</sub> = LCDV<sub>SS1</sub> = 0V

Parameter	Symbol	Pin/Remarks	Conditions	Specification				unit
				V <sub>DD</sub> [V]	min	typ	max	
High level input current	I <sub>IH</sub> (1)	PORT 0, 1, 2	Output disabled Pull-up resistor OFF V <sub>IN</sub> =V <sub>DD</sub> (including OFF state leak current of the output Tr.)	2.7 to 5.5			1	μA
	I <sub>IH</sub> (2)	RESB	V <sub>IN</sub> =V <sub>DD</sub>	2.7 to 5.5			1	
Low level input current	I <sub>IL</sub> (1)	PORT 0, 1, 2	Output disabled Pull-up resistor OFF V <sub>IN</sub> =V <sub>SS</sub> (including OFF state leak current of the output Tr.)	2.7 to 5.5	-1			μA
	I <sub>IL</sub> (2)	PORT 0, 1, 2	Output disabled Pull-up resistor ON	4.5 to 5.5	-117		-25	
	I <sub>IL</sub> (3)			2.7 to 3.0	-31		-5.8	
	I <sub>IL</sub> (4)	RESB	V <sub>IN</sub> =V <sub>SS</sub> (including OFF state leak current of the output Tr.)	4.5 to 5.5	-10.2		-3.7	
	I <sub>IL</sub> (5)			2.7 to 3.0	-6.3		-2.4	
High level output current	I <sub>OH</sub> (1)	CMOS output mode PORT0, 2	V <sub>OH</sub> (1)=V <sub>DD</sub> -1.0V	4.5 to 5.5			-3.7	mA
	I <sub>OH</sub> (2)			2.7 to 3.0			-1.6	
	I <sub>OH</sub> (3)	CMOS output mode PORT1	V <sub>OH</sub> (1)=V <sub>DD</sub> -1.0V	4.5 to 5.5			-10	
	I <sub>OH</sub> (4)			2.7 to 3.0			-4.5	
Low level output current	I <sub>OL</sub> (1)	PORT0, 2	V <sub>OL</sub> (1)=V <sub>SS</sub> +1.0V	4.5 to 5.5	10			mA
	I <sub>OL</sub> (2)			2.7 to 3.0	4.4			
	I <sub>OL</sub> (3)	PORT1		4.5 to 5.5	14.5			
	I <sub>OL</sub> (4)			2.7 to 3.0	6.5			
	I <sub>OL</sub> (5)	SEG71 to SEG56		4.5 to 5.5	0.5			
	I <sub>OL</sub> (6)			2.7 to 3.0	0.5			
Common output current	I <sub>OH</sub> (5)	COM0 to COM15	V <sub>OH</sub> (2)=V <sub>LCD</sub> 4-0.05V	2.7 to 5.5			-25	μA
	I <sub>OL</sub> (7)		V <sub>OL</sub> (2)=V <sub>SS</sub> +0.05V		25			
Segment output current	I <sub>OH</sub> (6)	SEG0 to SEG71	V <sub>OH</sub> (2)=V <sub>LCD</sub> 4-0.05V	2.7 to 5.5			-10	
	I <sub>OL</sub> (8)		V <sub>OL</sub> (2)=V <sub>SS</sub> +0.05V		10			
Hysteresis voltage	VHYS(1)	PORT 0, 1, 2 RESB		2.7 to 5.5		0.1V <sub>DD</sub>		V
Pin capacitance	CP	All pins	For pins other than that under test: V <sub>IN</sub> =V <sub>SS</sub> f=1MHz Ta=25°C	2.7 to 5.5		10		pF



## LC88F83B0A

**LCD Drive Voltage** at Ta = -20°C to +75°C, V<sub>SS</sub> = LCDV<sub>SS0</sub> = LCDV<sub>SS1</sub> = 0V

Special notes: 0.1μF capacitor must be connected to V<sub>LCD1</sub>, V<sub>LCD2</sub>, V<sub>LCD3</sub>, and V<sub>LCD4</sub>. (with no panel load)

Parameter	Symbol	Pin/Remarks	Conditions	Specification				
				V <sub>DD</sub> [V]	min	typ	max	unit
LCD drive voltage	V <sub>LCD1</sub>	V <sub>DD</sub> V <sub>LCD1</sub>	Contrast "00"	2.4 to 5.5	Typ ×0.88	1.030	Typ ×1.10	V
			Contrast "01"			1.045		
			Contrast "02"			1.060		
			Contrast "03"			1.075		
			Contrast "04"			1.090		
			Contrast "05"			1.105		
			Contrast "06"			1.120		
			Contrast "07"			1.135		
			Contrast "08"			1.150		
			Contrast "09"			1.165		
			Contrast "10"			1.180		
			Contrast "11"			1.195		
			Contrast "12"			1.210		
			Contrast "13"			1.225		
			Contrast "14"			1.240		
			Contrast "15"			1.255		
	V <sub>LCD2</sub>					2×V <sub>LCD1</sub>		
	V <sub>LCD3</sub>					3×V <sub>LCD1</sub>		
	V <sub>LCD4</sub>					4×V <sub>LCD1</sub>		

# LC88F83B0A

**Serial I/O Characteristics** at Ta = -20°C to +75°C, VSS = LCDVSS0 = LCDVSS1 = 0V

**1. SIO0 Serial I/O Characteristics (Wake-up function is not in use) (Note 4-1-1)**

Parameter	Symbol	Pin/Remarks	Conditions	V <sub>DD</sub> [V]	Specification					
					min	typ	max	unit		
Serial clock	Input clock	Frequency	tSCK(1)	SCK0(P12)	See Fig. 6.	2.3 to 5.5	4			tCYC
		Low level pulse width	tSCKL(1)				2			
		High level pulse width	tSCKH(1)				2			
			tSCKHA(1)	Automatic communication mode See Fig. 6.			6			
		tSCKHBSY(1a)	Automatic communication mode See Fig. 6.	23						
		tSCKHBSY(1b)	Excluding Automatic communication mode See Fig. 6.	4						
	Output clock	Frequency	tSCK(2)	SCK0(P12)	CMOS output selected See Fig. 6.	2.3 to 5.5	4			tSCK
		Low level pulse width	tSCKL(2)				1/2			
		High level pulse width	tSCKH(2)				1/2			
		tSCKHA(2)	Automatic communication mode CMOS output selected See Fig. 6.	6						
		tSCKHBSY(2a)	Automatic communication mode CMOS output selected See Fig. 6.	4				23		
		tSCKHBSY(2b)	Excluding automatic communication mode See Fig. 6.	4						
Serial input	Data setup time	tsDI(1)	SIO(P11), SB0(P11)	Must be specified with respect to rising edge of SIOCLK. See Fig. 6.	2.3 to 5.5	0.03				
	Data hold time	thDI(1)				0.03				
Serial output	Output delay time	tdD0(1)	SO0(P10), SB0(P11)	(Note4-1-2)	2.3 to 5.5			1tCYC +0.05	μs	
		tdD0(2)		(Note4-1-2)				1tCYC +0.05		

Note 4-1-1: These specifications are theoretical values. Add margin depending on its use.

Note 4-1-2: Must be specified with respect to falling edge of SIOCLK. Must be specified as the time to the beginning of output state change in open drain output mode. See Fig.6.

# LC88F83B0A

## 2. SIO1 Serial I/O Characteristics (Wake-up function is not in use) (Note 4-2-1)

Parameter	Symbol	Pin/Remarks	Conditions	V <sub>DD</sub> [V]	Specification				
					min	typ	max	unit	
Serial clock Input clock	Frequency	tSCK(3)	SCK0(P12)	See Fig. 6.	2.3 to 5.5	2			tCYC
	Low level pulse width	tSCKL(3)				1			
	High level pulse width	tSCKH(3)				1			
		tSCKHBSY(3)				2			
Serial input	Data setup time	tsDI(2)	SI0(P11), SB0(P11)	Must be specified with respect to rising edge of SIOCLK. See Fig. 6.	2.3 to 5.5	0.03			μs
	Data hold time	thDI(2)				0.03			
Serial output Input clock	Output delay time	tdD0(3)	SO0(P10), SB0(P11)	(Note4-2-2)	2.3 to 5.5			1tCYC +0.05	

Note 4-2-1: These specifications are theoretical values. Add margin depending on its use.

Note 4-2-2: Must be specified with respect to falling edge of SIOCLK. Must be specified as the time to the beginning of output state change in open drain output mode. See Fig.6.

### UART2 Operating Conditions at Ta = -20 to +75°C, V<sub>SS</sub> = LCDV<sub>SS0</sub> = LCDV<sub>SS1</sub> = 0V

Parameter	Symbol	Pin/Remarks	Conditions	V <sub>DD</sub> [V]	Specification			
					min	typ	max	unit
Transfer rate	UBR2	URX2(P16), UTX2(P17)		2.3 to 5.5	8		4096	tCYC

### Pulse Input Conditions at Ta = -20 to +75°C, V<sub>SS</sub> = LCDV<sub>SS0</sub> = LCDV<sub>SS1</sub> = 0V

Parameter	Symbol	Pin/Remarks	Conditions	V <sub>DD</sub> [V]	Specification			
					min	typ	max	unit
High/low level pulse width	tPIL(1)	RESB	Resetting is enabled.	2.3 to 5.5	50			μs

# LC88F83B0A

## AD Converter Characteristics at $V_{SS} = LCDV_{SS0} = LCDV_{SS1} = 0V$

<12-bits AD Converter Mode/ $T_a = -10^{\circ}C$  to  $+75^{\circ}C$ >

Parameter	Symbol	Pin/Remarks	Conditions	Specification				
				$V_{DD}[V]$	min	typ	max	unit
Resolution	N	AN0(SEG71) to AN3(SEG68)		2.9 to 5.5		12		bit
Absolute accuracy	ET		(Note7-1)	2.9 to 5.5			$\pm 16$	LSB
Conversion time	TCAD		See Conversion time calculation formulas. (Note7-2)	2.9 to 5.5	90		130	$\mu s$
Analog input voltage range	VAIN			2.9 to 5.5	$V_{SS}$		$V_{DD}$	V
Analog ports input current	IAINH		$VAIN = V_{DD}$	2.9 to 5.5			1	$\mu A$
	IAINL	$VAIN = V_{SS}$	2.9 to 5.5	-1				

<8-bits AD Converter Mode/ $T_a = -10^{\circ}C$  to  $+75^{\circ}C$ >

Parameter	Symbol	Pin/Remarks	Conditions	Specification				
				$V_{DD}[V]$	min	typ	max	unit
Resolution	N	AN0(SEG71) to AN3(SEG68)		2.9 to 5.5		8		bit
Absolute accuracy	ET		(Note7-1)	2.9 to 5.5			$\pm 1.5$	LSB
Conversion time	TCAD		See Conversion time calculation formulas. (Note7-2)	2.9 to 5.5	55		75	$\mu s$
Analog input voltage range	VAIN			2.9 to 5.5	$V_{SS}$		$V_{DD}$	V
Analog ports input current	IAINH		$VAIN = V_{DD}$	2.9 to 5.5			1	$\mu A$
	IAINL	$VAIN = V_{SS}$	2.9 to 5.5	-1				

<Conversion Time Calculation Formulas>

12-bits AD Converter Mode:  $TCAD$  (Conversion time) =  $((52/(\text{Division ratio}))+2) \times tCYC$

8-bits AD Converter Mode:  $TCAD$  (Conversion time) =  $((32/(\text{Division ratio}))+2) \times tCYC$

<Recommended Operating Conditions>

External Oscillator $FmCF$ [MHz]	Operating Supply Voltage Range $V_{DD}$ [V]	System Division Ratio ( $SYSDIV$ )	Cycle Time $tCYC$ [ns]	AD Division Ratio ( $ADDIV$ )	AD Conversion Time ( $TCAD$ )[ $\mu s$ ]	
					12-bit AD	8-bit AD
CF-4	2.9 to 4.0	1/1	250	1/8	104.5	64.5
		1/2	500	1/4	105.0	65.0

Note 7-1: The quantization error ( $\pm 1/2LSB$ ) must be excluded from the absolute accuracy. The absolute accuracy must be measured in the microcontroller's state in which no I/O operations occur at the pins adjacent to the analog input channel.

Note 7-2: The conversion time refers to the period from the time an instruction for starting a conversion process till the time the conversion results register(s) are loaded with a complete digital conversion value corresponding to the analog input value.

The conversion time is 2 times the normal-time conversion time when:

- The first AD conversion is performed in the 12-bit AD conversion mode after a system reset.
- The first AD conversion is performed after the AD conversion mode is switched from 8-bit to 12-bit conversion mode.

# LC88F83B0A

## Consumption Current Characteristics at Ta = -20 to +75°C, V<sub>SS</sub> = LCDV<sub>SS0</sub> = LCDV<sub>SS1</sub> = 0V

Parameter	Symbol	Pin/ Remarks	Conditions		Specification				
					V <sub>DD</sub> [V]	min	typ	max	unit
Consumption current during normal operation (Note 8-1)	IDDOP(1)	V <sub>DD</sub>	Crystal oscillation mode • FOSC0=32.768kHz • System clock: FOSC0 • Internal RC oscillation stopped • FOSC1=0Hz (Oscillation stop) • 1/1frequency division ratio. [No panel load]	LCD Display ON	2.4 to 5.5		70	150	μA
					2.4 to 3.6		50	80	
	IDDOP(2)			LCD Display OFF	2.3 to 5.5		70	120	
	IDDOP(3)				2.3 to 3.6		40	70	
	IDDOP(4)		Ceramic oscillation mode • FOSC1=4MHz • System clock: FOSC1 • Internal RC oscillation stopped • FOSC0=0Hz (Oscillation stop) • 1/2 frequency division ratio.	2.4 to 5.5		3000	4100		
	IDDOP(5)			2.4 to 3.6		2200	2900		
	IDDOP(6)		Internal RC oscillation mode • System clock: Internal RC • Internal RC oscillates • FOSC0=0Hz (Oscillation stop) • FOSC1=0Hz (Oscillation stop) • 1/1 frequency division ratio	2.3 to 5.5		1900	3000		
	IDDOP(7)			2.3 to 3.6		1200	2000		
	IDDOP(8)		High-speed RC oscillation mode *Ta=0 to 60°C • FOSC1=1MHz RCR1=470kΩ • System clock: FOSC1 • Internal RC oscillation stopped • FOSC0=0Hz (Oscillation stop) • 1/1 frequency division ratio.	2.3 to 5.5		1700	2300		
	IDDOP(9)			2.3 to 3.6		1200	1700		
	IDDOP(10)		Low-speed RC oscillation mode *Ta=0 to 60°C • FOSC0=64kHz RCR0=910kΩ • System clock: FOSC0 • Internal RC oscillation stopped • FOSC1=0Hz (Oscillation stop) • 1/1 frequency division ratio.	2.3 to 5.5		110	170		
	IDDOP(11)			2.3 to 3.6		70	110		
IDDOP(12)									

Note 8-1: The consumption current value includes none of the currents that flow into the output Tr and internal pull-up resistors.

Continued on next page.

# LC88F83B0A

Continued from preceding page.

Parameter	Symbol	Pin/ Remarks	Condition	Specification				
				V <sub>DD</sub> [V]	min	typ	max	unit
Consumption current during HALT mode (Note 8-1)	IDDHALT(1)	V <sub>DD</sub>	HALT mode LCD Display ON Crystal oscillation mode • FOSC0=32.768kHz • System clock: FOSC0 • Internal RC oscillation stopped • FOSC1=0Hz (Oscillation stop) • 1/1 frequency division ratio. [No panel load]	2.4 to 5.5		32	93	μA
	IDDHALT(2)							
	IDDHALT(3)			2.3 to 5.5		22	59	
	IDDHALT(4)							
	IDDHALT(5)		2.4 to 5.5		700	1100		
	IDDHALT(6)						2.4 to 3.6	
	IDDHALT(7)		2.3 to 5.5		400	700		
	IDDHALT(8)						2.3 to 3.6	
	IDDHALT(9)		2.3 to 5.5		200	400		
	IDDHALT(10)						2.3 to 3.6	
	IDDHALT(11)		2.3 to 5.5		20	50		
	IDDHALT(12)						2.3 to 3.6	
Consumption current during HOLD mode	IDDHOLD(1)	V <sub>DD</sub>	HOLD mode • CF1=V <sub>DD</sub> or OPEN (External clock mode)	2.3 to 5.5				12
	IDDHOLD(2)			2.3 to 3.6			5	
Consumption current during clock HOLD mode	IDDHOLD(3)	V <sub>DD</sub>	Clock HOLD mode • CF1=V <sub>DD</sub> or OPEN (External clock mode) • FmX'tal=32.768kHz crystal oscillation mode	2.3 to 5.5		16	55	
	IDDHOLD(4)			2.3 to 3.6		3	16	

Note 8-1: The consumption current value includes none of the currents that flow into the output Tr and internal pull-up resistors.

## F-ROM Programming Characteristics at Ta = +10°C to +55°C, V<sub>SS</sub> = LCDV<sub>SS0</sub> = LCDV<sub>SS1</sub> = 0V

Parameter	Symbol	Pin/ Remarks	Conditions	Specification				
				V <sub>DD</sub> [V]	min	typ	max	unit
Onboard programming current	IDDFW(1)	V <sub>DD</sub>	The consumption current of the microcomputer is excluded.	2.7 to 5.5		5	10	mA
Programming time	tFW(1)		Erasing time: 128 bytes	2.7 to 5.5		20	30	ms
	tFW(2)		Programming time: 2 bytes	2.7 to 5.5		40	60	μs

## Characteristics of a Sample OSC1 System Clock Oscillation Circuit

Given below are the characteristics of a sample OSC1 system clock oscillation circuit that are measured using a Our designated oscillation characteristics evaluation board and external components with circuit constant values with which the oscillator vendor confirmed normal and stable oscillation.

Table 1 Characteristics of a Sample OSC1 System Clock Oscillator Circuit with a Ceramic Oscillator

Nominal Frequency	Vendor Name	Oscillator Name	Circuit Constant				Operating Voltage Range [V]	Oscillation Stabilization Time		Remarks
			C1 [pF]	C2 [pF]	Rf1 [ $\Omega$ ]	Rd1 [ $\Omega$ ]		typ [ms]	max [ms]	
4.194MHz	MURATA	CSTCR4M00G53-R0	(15)	(15)	OPEN	0	2.4 to 5.5	0.1	0.5	Internal C1,C2
		CSTLS4M00G53-B0	(15)	(15)	OPEN	0	2.4 to 5.5	0.1	0.5	
4.000MHz	MURATA	CSTCR4M00G53-R0	(15)	(15)	OPEN	0	2.4 to 5.5	0.1	0.5	Internal C1,C2
		CSTLS4M00G53-B0	(15)	(15)	OPEN	0	2.4 to 5.5	0.1	0.5	

The oscillation stabilization time refers to the time interval that is required for the oscillation to get stabilized after the following reference timing points: (See Figure 4)

- VDD goes above the operating voltage lower limit.
- An instruction for starting the OSC1 clock oscillator circuit is executed.
- Oscillation starts after the microcontroller exits the X'tal HOLD mode with the ENOSC1 bit (OCR0 register, bit 1) set to 1.

## Characteristics of a Sample OSC0 System Clock Oscillator Circuit

Given below are the characteristics of a sample OSC0 system clock oscillation circuit that are measured using a Our designated oscillation characteristics evaluation board and external components with circuit constant values with which the oscillator vendor confirmed normal and stable oscillation.

Table 2 Characteristics of a Sample OSC0 System Clock Oscillator Circuit with a CF Oscillator

Nominal Frequency	Vendor Name	Oscillator Name	Circuit Constant				Operating Voltage Range [V]	Oscillation Stabilization Time		Remarks
			C3 [pF]	C4 [pF]	Rf2 [ $\Omega$ ]	Rd2 [ $\Omega$ ]		typ [s]	max [s]	
32.768kHz	EPSON TOYOCOM	MC-306	18	18	OPEN	390k	2.3 to 5.5	1.3	3.0	Applicable CL value=12.5pF SMD-type

The oscillation stabilization time refers to the time interval that is required for the oscillation to get stabilized after the instruction for starting the OSC0 clock oscillation circuit is executed. (See Figure 4)

Note: The components that are involved in oscillation should be placed as close to the IC and to one another as possible because they are vulnerable to the influences of the circuit pattern.

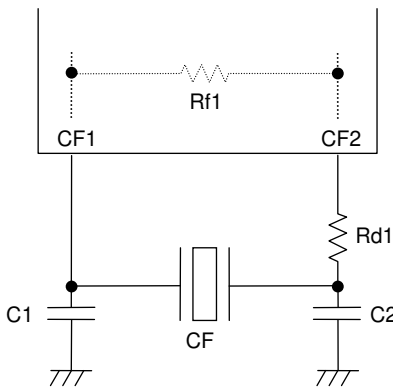

Figure 1 CF Oscillator Circuit

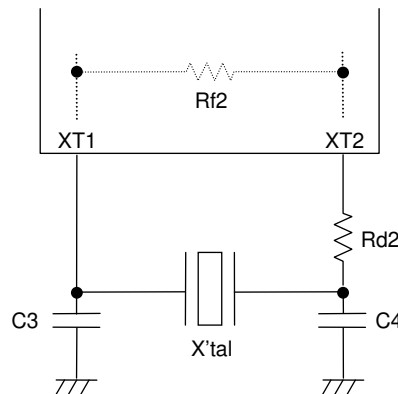

Figure 2 XT Oscillator Circuit

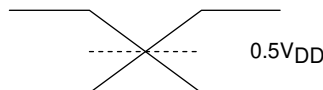
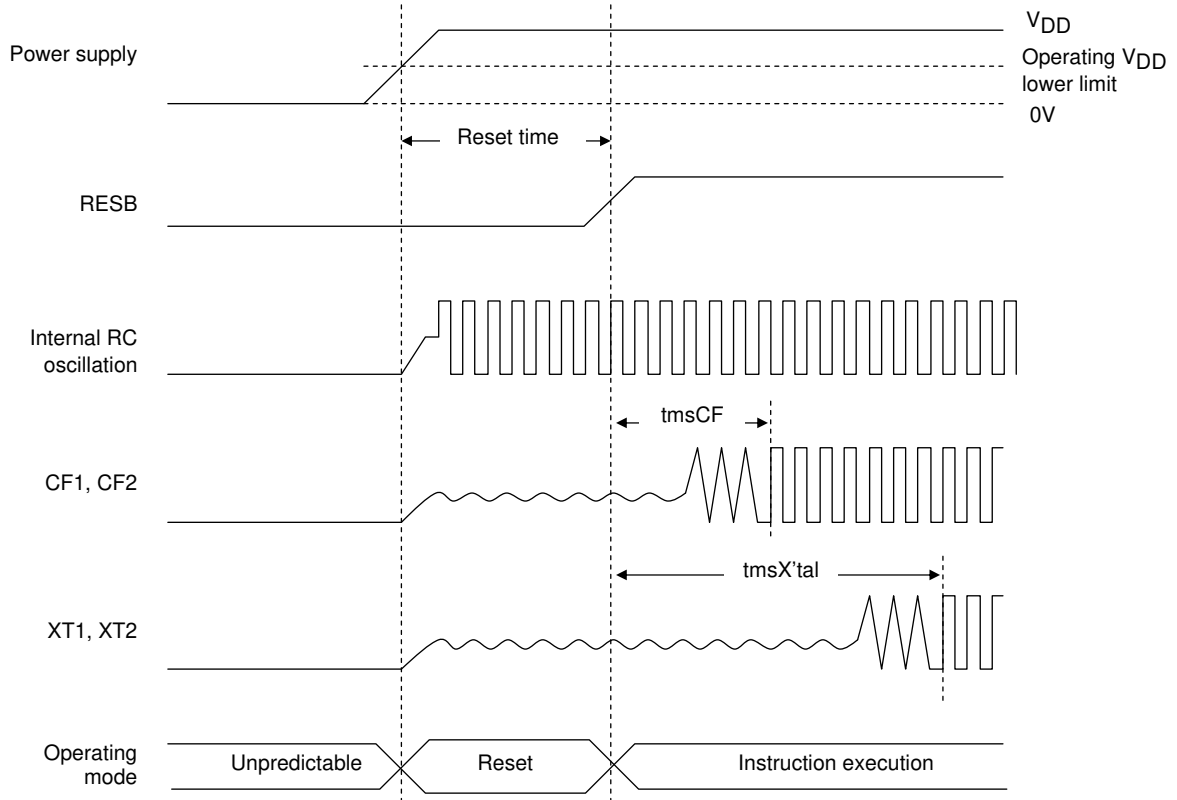
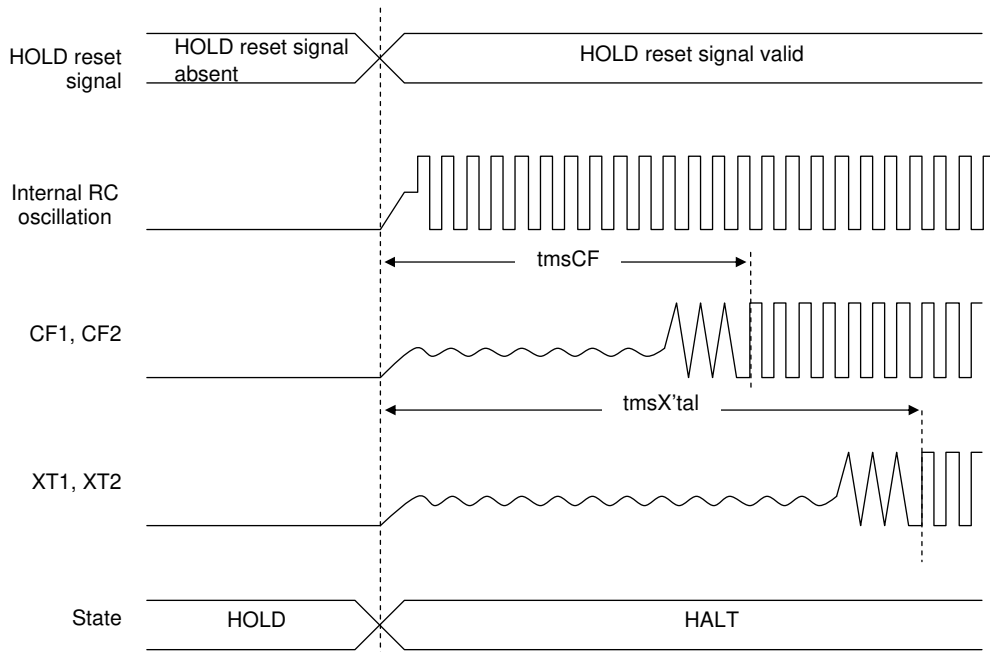

Figure 3 AC Timing Measurement Point

# LC88F83B0A



## Reset Time and Oscillation Stabilization Time



## HOLD Reset Signal and Oscillation Stabilization Time

Figure 4 Oscillation Stabilization Time



# LC88F83B0A

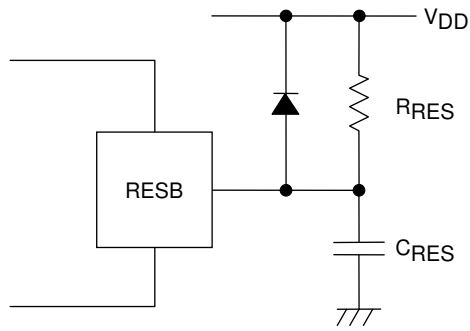

Note:  
Select  $C_{RES}$  and  $R_{RES}$  values to assure that at least  $50\mu s$  reset time is provided after the  $V_{DD}$  becomes higher than the minimum operating voltage.

Figure 5 Reset Circuit

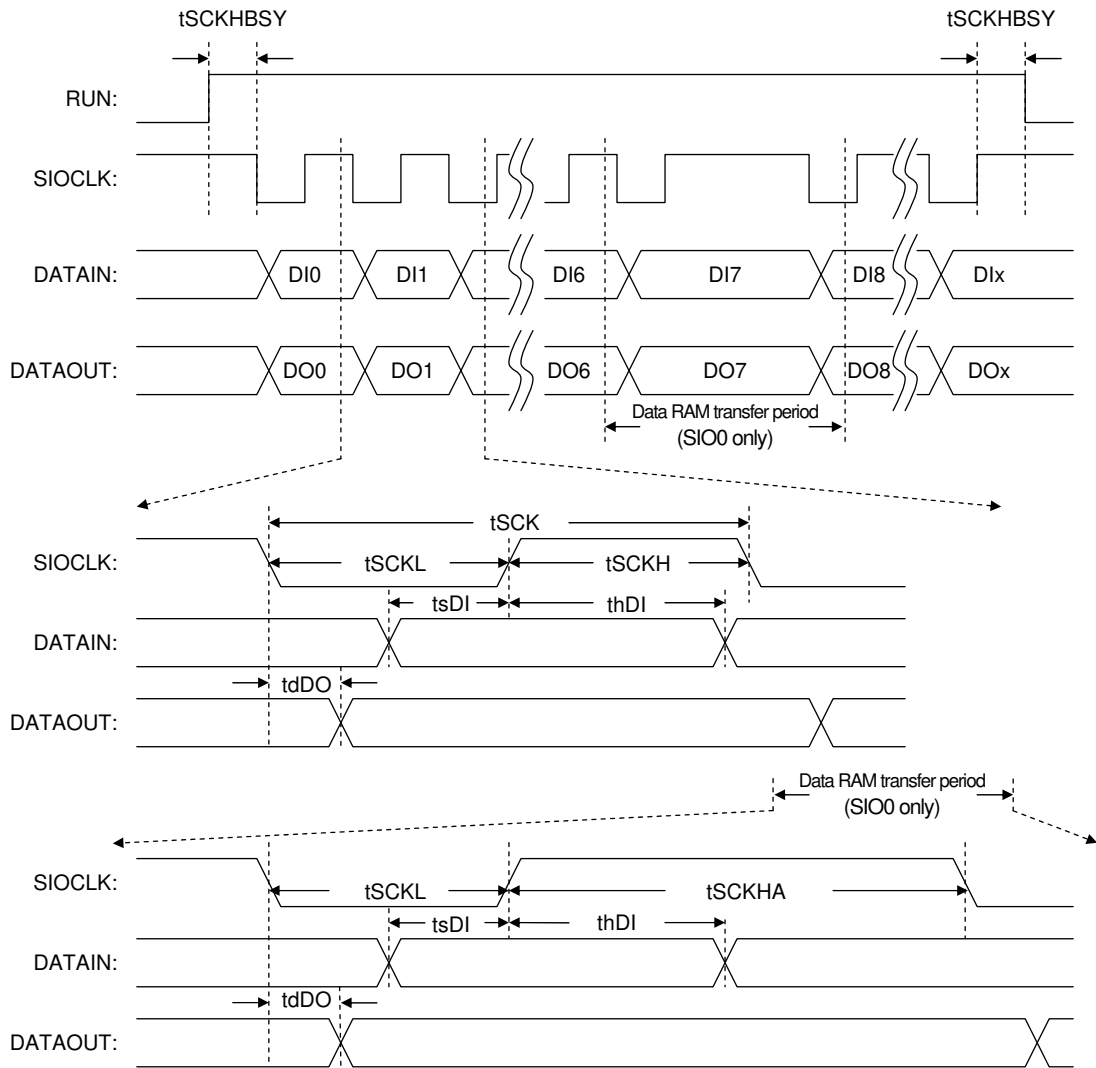

\*: Remarks: DIx and DOx are the final communication bits. X = 0 to 32768

Figure 6 Serial I/O Waveforms

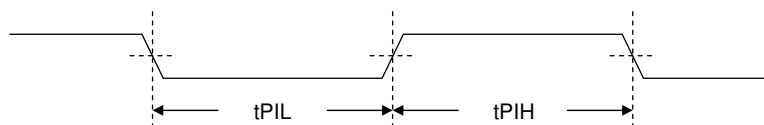

Figure 7 Pulse Input Timing Signal Waveform

# LC88F83B0A

Note: The oscillation frequency changes with the board pattern and used parts when OSC1 and OSC0 are used as the RC oscillation. It also greatly depends on the product shape (chip and plastic package) and the board capacitance, and it is recommended to evaluate the resistor value with an actual product. Use the following characteristics as only for a reference.

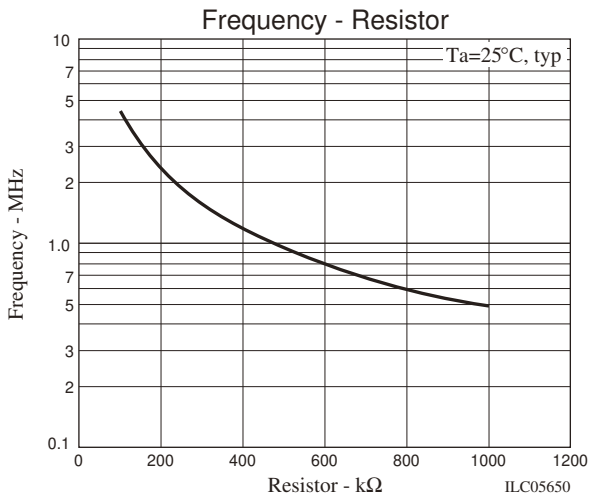

Figure 8 Characteristics of Resistor v.s. Frequency of OSC1

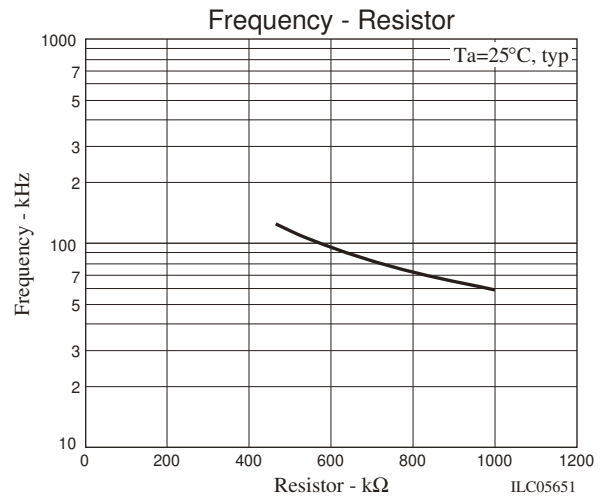

Figure 9 Characteristics of Resistor v.s. Frequency of OSC0

ON Semiconductor and the ON logo are registered trademarks of Semiconductor Components Industries, LLC (SCILLC). SCILLC owns the rights to a number of patents, trademarks, copyrights, trade secrets, and other intellectual property. A listing of SCILLC's product/patent coverage may be accessed at [www.onsemi.com/site/pdf/Patent-Marking.pdf](http://www.onsemi.com/site/pdf/Patent-Marking.pdf). SCILLC reserves the right to make changes without further notice to any products herein. SCILLC makes no warranty, representation or guarantee regarding the suitability of its products for any particular purpose, nor does SCILLC assume any liability arising out of the application or use of any product or circuit, and specifically disclaims any and all liability, including without limitation special, consequential or incidental damages. "Typical" parameters which may be provided in SCILLC data sheets and/or specifications can and do vary in different applications and actual performance may vary over time. All operating parameters, including "Typicals" must be validated for each customer application by customer's technical experts. SCILLC does not convey any license under its patent rights nor the rights of others. SCILLC products are not designed, intended, or authorized for use as components in systems intended for surgical implant into the body, or other applications intended to support or sustain life, or for any other application in which the failure of the SCILLC product could create a situation where personal injury or death may occur. Should Buyer purchase or use SCILLC products for any such unintended or unauthorized application, Buyer shall indemnify and hold SCILLC and its officers, employees, subsidiaries, affiliates, and distributors harmless against all claims, costs, damages, and expenses, and reasonable attorney fees arising out of, directly or indirectly, any claim of personal injury or death associated with such unintended or unauthorized use, even if such claim alleges that SCILLC was negligent regarding the design or manufacture of the part. SCILLC is an Equal Opportunity/Affirmative Action Employer. This literature is subject to all applicable copyright laws and is not for resale in any manner.