



Chipsmall Limited consists of a professional team with an average of over 10 year of expertise in the distribution of electronic components. Based in Hongkong, we have already established firm and mutual-benefit business relationships with customers from,Europe,America and south Asia,supplying obsolete and hard-to-find components to meet their specific needs.

With the principle of "Quality Parts,Customers Priority,Honest Operation,and Considerate Service",our business mainly focus on the distribution of electronic components. Line cards we deal with include Microchip,ALPS,ROHM,Xilinx,Pulse,ON,Everlight and Freescale. Main products comprise IC,Modules,Potentiometer,IC Socket,Relay,Connector.Our parts cover such applications as commercial,industrial, and automotives areas.

We are looking forward to setting up business relationship with you and hope to provide you with the best service and solution. Let us make a better world for our industry!



Contact us

Tel: +86-755-8981 8866 Fax: +86-755-8427 6832

Email & Skype: info@chipsmall.com Web: www.chipsmall.com

Address: A1208, Overseas Decoration Building, #122 Zhenhua RD., Futian, Shenzhen, China



PART NUMBER	MATERIAL
LEWSE-27-01	NYLON 6/6 UL 94 V-2 (RMS-01)

REV.	MODIFICATION.	DATE	DRN
01	SALES RELEASE	25/03/09	TC
02	CO2010719	18/06/09	SF
03	CO2010720	19/06/09	SF

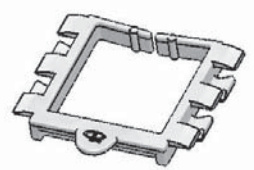
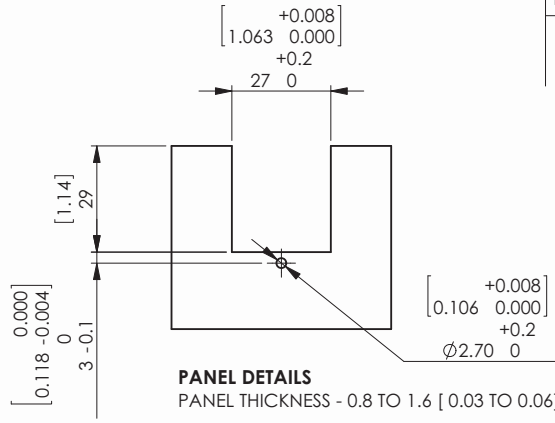
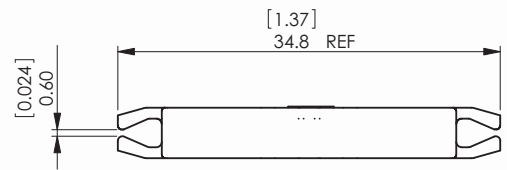

PANEL DETAILS
 PANEL THICKNESS - 0.8 TO 1.6 [0.03 TO 0.06]

- NOTES.
- PARTS AVAILABLE IN NYLON 6/6 UL 94 V-0(RMS-19) MATERIAL BY SPECIAL ORDER. USE LEWSE-27-19 TO ORDER.
 - PARTS ALSO AVAILABLE IN NYLON 4/6 UL 94 V-2 (RMS-109) MATERIAL BY SPECIAL ORDER. USE LEWSE-27-109 TO ORDER.

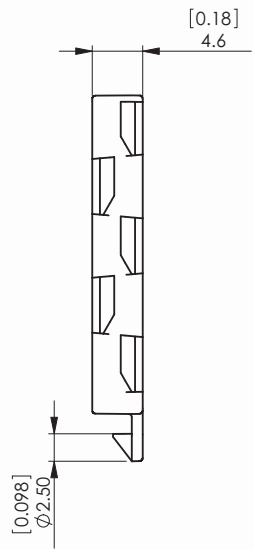
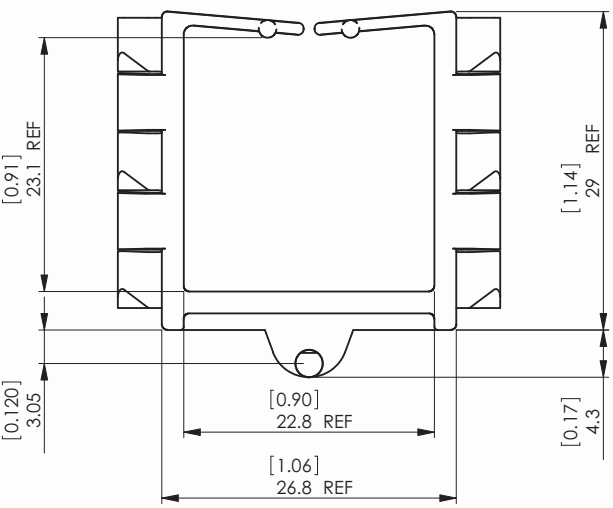

ALTERNATE UNITS FOR REFERENCE ONLY

INFORMATION CONTAINED IN THIS DOCUMENT IS CONFIDENTIAL TO RICHCO INTERNATIONAL Co. Ltd. AND MAY NOT BE DISCLOSED OR REPRODUCED IN WHOLE OR PART WITHOUT THEIR WRITTEN CONSENT.

ALL DIMENSIONS IN mm
 GENERAL TOLERANCES ±0.25
 UNLESS OTHERWISE STATED
 1 DECIMAL PLACE ±
 2 DECIMAL PLACES ±
 ANGULAR ±1°

THIRD ANGLE

MATERIAL: SEE TABLE		COLOUR: NATURAL	
DESCRIPTION: EDGE WIRE SADDLE		PART No: SEE TABLE	
DRG No: 09-029	NPR No: DE08-0120	SHEET SIZE A4	
DRN PH	DATE 08/01/09	CHKD TC	DATE 25/03/09
SCALE NTS	SHEET No. 1 OF 1		

FORM No. 0143/00