



Chipsmall Limited consists of a professional team with an average of over 10 year of expertise in the distribution of electronic components. Based in Hongkong, we have already established firm and mutual-benefit business relationships with customers from,Europe,America and south Asia,supplying obsolete and hard-to-find components to meet their specific needs.

With the principle of “Quality Parts,Customers Priority,Honest Operation,and Considerate Service”,our business mainly focus on the distribution of electronic components. Line cards we deal with include Microchip,ALPS,ROHM,Xilinx,Pulse,ON,Everlight and Freescale. Main products comprise IC,Modules,Potentiometer,IC Socket,Relay,Connector.Our parts cover such applications as commercial,industrial, and automotives areas.

We are looking forward to setting up business relationship with you and hope to provide you with the best service and solution. Let us make a better world for our industry!



Contact us

Tel: +86-755-8981 8866 Fax: +86-755-8427 6832

Email & Skype: info@chipsmall.com Web: www.chipsmall.com

Address: A1208, Overseas Decoration Building, #122 Zhenhua RD., Futian, Shenzhen, China



DCSA SERIES

Current Transducers



Wiring Diagram

CONNECTION FOR 4 - 20 MA LOOP

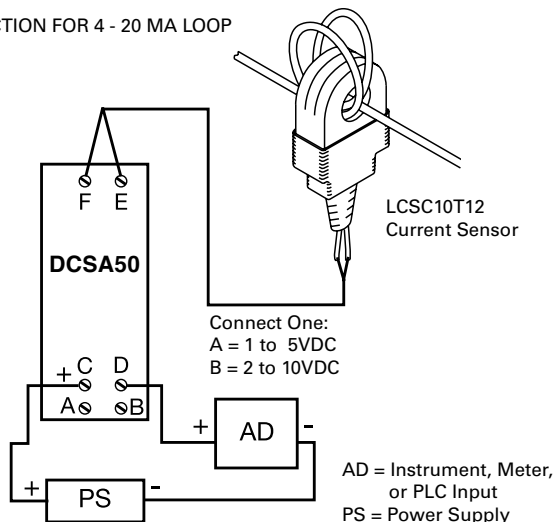

Description

The DCSA Series is a loop-powered, linear output current transducer that provides an output that is directly proportional to the RMS AC current passing through the LCSC10T12 sensor. The DCSA Series provides either an analog current or voltage: 4-20 mA, 1 to 5VDC, or 2 to 10VDC. Each unit is factory calibrated for monitoring (with the LCSC10T12 connected) in one of four ranges; 0-5, 0-10, 0-20, or 0-50A. Zero and span adjustments allow field calibration if needed. The DCSA Series mounts on both DIN 1 and DIN 3 rails.

Operation

The DCSA Series varies the effective resistance of its output in direct proportion to the current flowing in the conductor monitored by the LCSC10T12. Connecting the power supply to terminals C & D provides a 4 to 20mA DC current. Connect the power supply to terminals C & A to get 1 to 5VDC at terminal D. Connect the power supply to terminals C & B to get 2 to 10VDC at terminal D.

Features

- Mounts on DIN 1 or DIN 3 rail
- 0-50A in 4 ranges using LCSC10T12 sensor
- Loop powered from 10 to 30VDC
- Linear output from 4-20mA, 1-10VDC
- Zero & span adjustments
- Separate sensor & control unit

Accessories



LCSC10T12 Toroidal Current Sensor
Remote monitoring of currents up to 50A.

To LCSC10T12 Current Sensor

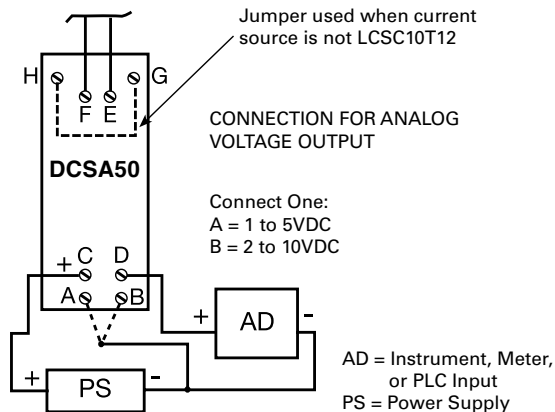

Ordering Information

MODEL	CURRENT RANGE WITH LCSC10T12	INPUT RANGE (F TO E)
DCSA5	0-5A	0-5mA AC
DCSA20	0-20A	0-20mA AC
DCSA50	0-50A	0-50mA AC

If you don't find the part you need, call us for a custom product 800-843-8848

DCSA SERIES

Specifications

Input

Ranges (without

LCSC10T12 connected)

4 factory calibrated ranges

in mA AC

0 - 5mA, 0 - 10mA, 0 - 20mA, or 0 - 50mA AC

Factory calibration

±0.5% of full scale

Repeat Accuracy

±0.25% of full scale under fixed conditions

Response Time

≈ 300ms

Temperature Coefficient

±0.05%/°C

Input to Output

Not isolated

Output

Type

Current directly proportional to input current

Analog

Range

4 - 20mA, or 1 to 5VDC or 2 to 10VDC

Supply Voltage*

10 to 30VDC

Momentary Voltage

40VDC for 1m

Zero Adjust

≈ 3.75 - 4.25mA

Span Adjust

18mA - 22mA

Adjustment

Mini-screw, multi-turn potentiometer

Protection

Dielectric Breakdown

≥ 2500V RMS terminals to mounting surface

Insulation Resistance

≥ 100 MΩ

Polarity

Units are reverse polarity protected

Mechanical

Mounting

DIN 1 & DIN 3 rail mounting

Termination

Wire clamp

For 22 - 14AWG (.336 mm² ... 2.5 mm²)

Environmental

Operating/Storage

Temperature

-30° to 60°C / -40° to 85°C

Humidity

95% relative, non-condensing

Weight

≈ 1.6 oz (45.4 g)

Accessory - LCSC10T12 Toroidal Sensor

Number of Turns 1000

Nominal Output Current

Full Range 0 - 50 mA

Maximum Allowable Current Steady 50A turns; Inrush 300A turns for 10s

Burden ≤ 0.5 VA

Frequency

0 - 20A / 21 - 50A 20/100 Hz / 30/100 Hz

Sensor Hole 0.36 in. (9.14 mm) for up to #4 AWG

(21.1 mm²) THHN wire

Weight ≈ 1 oz (28.3 g)

*Minimum loop-power supply voltage equals the minimum sensor voltage 10VDC plus the voltage drop developed across all the other loop devices at 20mA.

Monitored Current Amps Diagram

