



Chipsmall Limited consists of a professional team with an average of over 10 year of expertise in the distribution of electronic components. Based in Hongkong, we have already established firm and mutual-benefit business relationships with customers from,Europe,America and south Asia,supplying obsolete and hard-to-find components to meet their specific needs.

With the principle of “Quality Parts,Customers Priority,Honest Operation,and Considerate Service”,our business mainly focus on the distribution of electronic components. Line cards we deal with include Microchip,ALPS,ROHM,Xilinx,Pulse,ON,Everlight and Freescale. Main products comprise IC,Modules,Potentiometer,IC Socket,Relay,Connector.Our parts cover such applications as commercial,industrial, and automotives areas.

We are looking forward to setting up business relationship with you and hope to provide you with the best service and solution. Let us make a better world for our industry!



Contact us

Tel: +86-755-8981 8866 Fax: +86-755-8427 6832

Email & Skype: info@chipsmall.com Web: www.chipsmall.com

Address: A1208, Overseas Decoration Building, #122 Zhenhua RD., Futian, Shenzhen, China



PART NUMBER	LCT-H480272M43W1	REV.	A
DATE	E.C.N. NUMBER AND REVISION COMMENTS		REV.
06.09.11	E.C.N. #10BRDR.		A

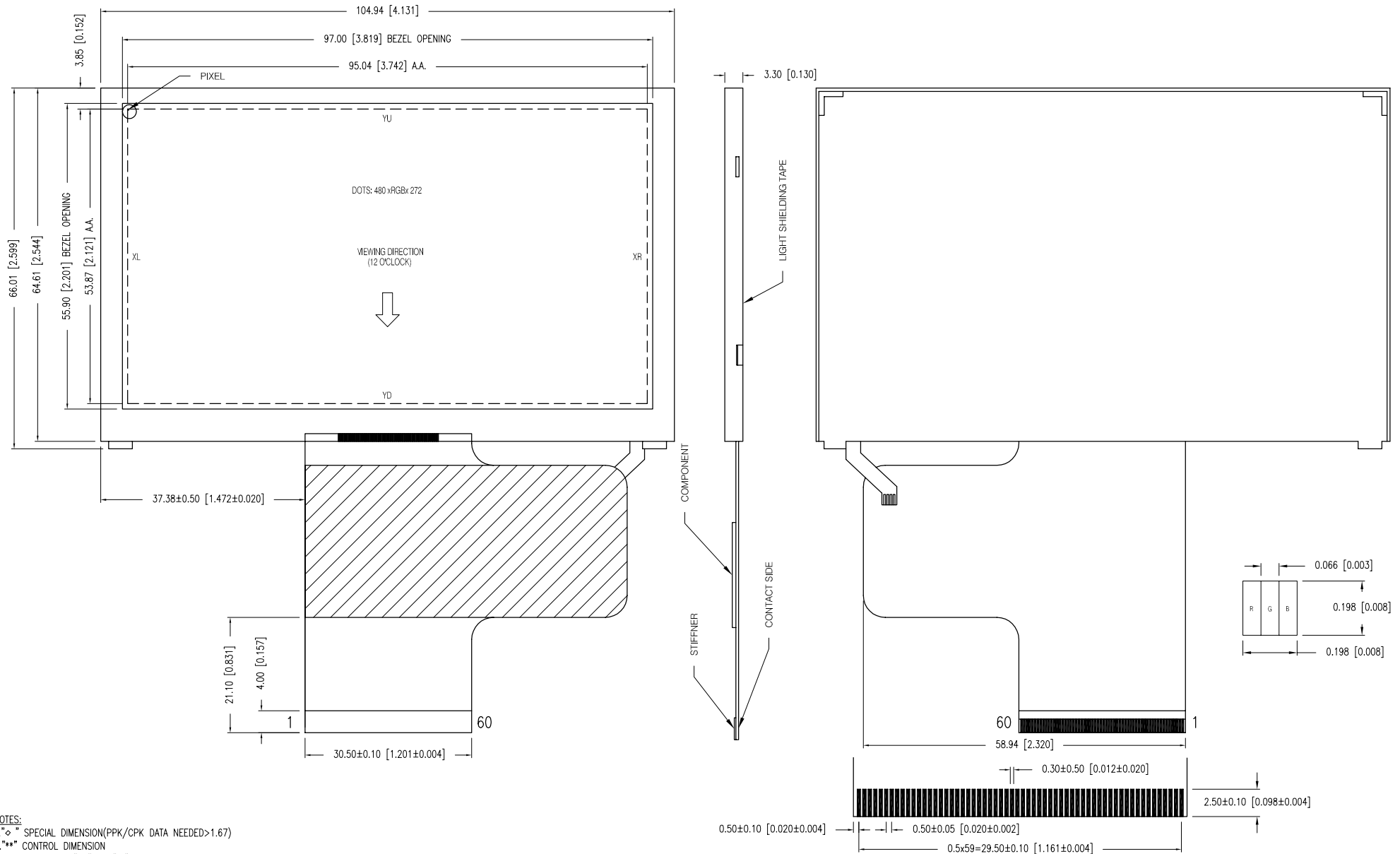

- NOTES:
1. "°" SPECIAL DIMENSION (PPK/CPK DATA NEEDED > 1.67)
 2. "M" CONTROL DIMENSION
 3. ALL UNMARKED "°" OR "M" DIMENSIONS ARE REFERENCE DIMENSIONS AND NO MEASUREMENT NEEDED.
 4. GREEN/ROHS PRODUCT : YES
 5. BACKLIGHT: WHITE LED: 8PCS, IF=2x15mA , VF~12.6V.
 6. IC P/N: HX8257-A CIRCUIT DESIGN
 7. THE SPECIFICATIONS MAY CHANGE AT ANY TIME WITHOUT NOTICE DUE TO NEW MATERIALS OR PRODUCT IMPROVEMENT.

*UNLESS OTHERWISE SPECIFIED TOLERANCES PER DECIMAL PRECISION ARE: X=±1 (±0.039), X.X=±0.5 (±0.020), X.XX=±0.25 (±0.010), X.XXX=±0.127 (±0.005). LEAD SIZE=±0.05 (±0.002), LEAD LENGTH=±0.75 (±0.030). MIN= ^{+0.00}DECIMAL PRECISION MAX.= ^{-0.00}DECIMAL PRECISION UNCONTROLLED DOCUMENT

LUMEX
 Creating LED and LCD Solutions Together™
 290 E. HELEN ROAD
 PALATINE, IL 60067-6976
 PHONE: +1.847.359.2790
 FAX: +1.847.359.6538
 WEB: WWW.LUMEX.COM

4.3" ACTIVE MATRIX FULL COLOR TFT PANEL, 6:00 VIEW, LED BACKLIGHT, -20°C TO +70°C OPERATING TEMP.
 THE SPECIFICATIONS MAY CHANGE AT ANY TIME WITHOUT NOTICE DUE TO NEW MATERIALS OR PRODUCT IMPROVEMENT.
 CONFIDENTIAL INFORMATION
 THE INFORMATION CONTAINED IN THIS DOCUMENT IS THE PROPERTY OF LUMEX INC. EXCEPT AS SPECIFICALLY AUTHORIZED IN WRITING BY LUMEX INC., THE HOLDER OF THIS DOCUMENT SHALL KEEP ALL INFORMATION CONTAINED HEREIN CONFIDENTIAL AND SHALL PROTECT SAME IN WHOLE OR IN PART FROM DISCLOSURE AND DISSEMINATION TO ALL THIRD PARTIES.

DATE:	06.25.09	DRAWN BY:	JN
PAGE:	1 OF 10	CHKD BY:	SS
SCALE:	NTS	APRVD BY:	SS
UNIT:	mm [INCH]		Ⓟ

PART NUMBER	LCT-H480272M43W1	REV.	A
DATE	E.C.N. NUMBER AND REVISION COMMENTS		REV.
06.09.11	E.C.N. #10BRDR.		A

INTERFACE PIN CONNECTION

PIN	SYMBOL	FUNCTION	PIN	SYMBOL	FUNCTION
1	NC	NOT CONNECT.	46	VDDIO	VOLTAGE INPUT PIN FOR I/O LOGIC.
2	NC	NOT CONNECT.	47	VC1	NOT CONNECT.
3	GND	POWER GROUND.	48	DRV1	POWER TRANSISTOR GATE SIGNAL FOR THE BOOST CONVERTER 1.1 PWM CAN BE USED FOR LED BACKLIGHT POWER.
4	VCOM	THIS OUTPUT PIN FOR COMMON SIGNAL OF A TFT PANEL.	49	VFB1	MAIN BOOST REGULATOR FEEDBACK INPUT 1. CONNECT FEEDBACK RESISTIVE DRIVER TO GND, IF 1 PWM IS NOT USED, PLEASE CONNECT VFB1 TO GND. VFB1 DEFAULT THRESHOLD IS 1.0V.
5	CPWM	DUTY CYCLE CONTROL SIGNAL OF CABG FUNCTION OUTPUT.	50	DRV1	POWER TRANSISTOR GATE SIGNAL FOR THE BOOST CONVERTER 2.2 PWM CAN BE USED TO GENERATE VCIX2J POWER IF NEEDED.
6	SDO	DATA OUTPUT PIN IN SERIAL MODE.	51	VFB2	MAIN BOOST REGULATOR FEEDBACK INPUT 2. CONNECT FEEDBACK RESISTIVE DRIVER TO GND, IF 2 PWM IS NOT USED, PLEASE CONNECT VFB2 TO GND. VFB2 DEFAULT THRESHOLD IS 1.0V.
7	SDI	DATA INPUT PIN IN SERIAL MODE.	52	VCOM	THIS IS OUTPUT PIN FOR COMMON SIGNAL OF A TFT PANEL.
8	SCL	CLOCK PIN OF SERIAL INTERFACE.	53~55	GND	POWER GROUND
9	CSB	CHIP SELECT PIN OF SERIAL INTERFACE. INTERNAL PULL HIGH. LEAVE IT OPEN WHEN NOT USED.	56	3-NC	NO CONNECTION.
10	PS	INPUT DATA FORMAT SELECT SIGNAL, INTERNALLY PULLED HIGH. A. PS=H: PARALELL RGB B. PS=L: SERIAL RGB	57	A1	ANODE OF BACKLIGHT POWER SUPPLY.
11	CLK_TRG	CLOCK EDGE SELECTION SIGNAL FOR THE DATA SAMPLING. INTERNALLY PULLED HIGH. A. CLK_TRG=H; DATA SAMPLING AT THE CLK FALLING EDGE. B. CLK_TRG=L; DATA SAMPLING AT THE CLK RISING EDGE.	58	A2	ANODE OF BACKLIGHT POWER SUPPLY.
12	LR	SHIFT DIRECTION SELECTION SIGNAL. A. UD=H: S1-S2...S720 B. UD=L: S720-G719..S1	59	K1	CATHODE OF BACKLIGHT POWER SUPPLY.
13	UD	SCAN DIRECTION SELECTION SIGNAL. INTERNALLY PULLED HIGH. A. UD=H: S1-S2...S720 B. UD=L: S720-G719..S1	60	K2	CATHODE OF BACKLIGHT POWER SUPPLY.
14	DE	INPUT DATA ENABLE CONTROL. INTERNALLY PULLED HIGH.			
15	VS	VERTICAL SYNC INPUT WITH NEGATIVE POLARITY. INTERNALLY PULLED HIGH.			
16	HS	HORIZONTAL SYNC INPUT WITH NEGATIVE POLARITY. INTERNALLY PULLED HIGH.			
17	DISP	SCAN DIRECTION SELECTION SIGNAL. INTERNALLY PULLED HIGH. A. DISP=L, STANDBY MODE. B. DISP=H, NORMAL DISPLAY MODE.			
18~25	CLK	CONTROL SIGNAL FOR DATA LATCHING AND INTERNAL COUNTER OF THE TIMING CONTROLLER.			
26~33	D27-D20	DIGITAL DATA INPUT. INTERNALLY PULLED LOW.			
34~41	D17-D10	A. PS=H (PARALELL RGB INTERFACE):Dx7~Dx0 ARE USED. B. PS=L (PARALELL RGB INTERFACE): ONLY D07~D00 ARE USED.			
42	D7-D0				
43	RESETB	ACTIVE LOW GLOBAL RESET SIGNAL INPUT. INTERNALLY PULLED HIGH.			
44	POL	POLARITY SIGNAL TO VCOM MONITOR.			
42	D7-D0	INPUT PIN TO ENABLE INTERNAL CHARGE PUMP CIRCUIT. INTERNALLY PULLED HIGH. -CONNECT TO VDDIO TO ENABLE INTERNAL CHARGE PUMP VCL,VGH, VGL. VCIX2 AND VCOM. -CONNECT TO DVSS TO DISABLE INTERNAL CHARGE PUMP VCL,VGH, VGL. VCIX2 AND VCOM.			

ITEM	CONTENTS	UNIT
LCD TYPE	TFT-COLOR TRANSMISSIVE LCD	-
MODULE OUTER DIMENSION	104.94 x 117.93 x 3.3	mm
PIXEL PITCH	202.7 x 202.7	µm
ACTIVE DISPLAY AREA	95.04 x 53.86	mm
NUMBER OF DOTS	480RGB x 272	DOTS
VIEWING DIRECTION	12	CLOCK
PIXEL ARRANGEMENT	RGB STRIPE	-
BACKLIGHT	LED WHITE BACKLIGHT	-
DRIVER IC	HX8257A	-
INTERFACE TYPE	PARALLEL RGB INTERFACE AND SERIAL RGB INTERFACE	-
NUMBER OF COLORS	16.7M	-
OPERATING TEMPERATURE	-20~70	°C
STORAGE TEMPERATURE	-30~80	°C
PIXEL DRIVING ELEMENT	a-Si TFT	-

*UNLESS OTHERWISE SPECIFIED TOLERANCES PER DECIMAL PRECISION ARE: X=±1 (±0.039), X.X=±0.5 (±0.020), X.XX=±0.25 (±0.010), X.XXX=±0.127 (±0.005). LEAD SIZE=±0.05 (±0.002), LEAD LENGTH=±0.75 (±0.030). MIN= ^{+0.00}DECIMAL PRECISION MAX.= ^{-0.00}DECIMAL PRECISION



290 E. HELEN ROAD
PALATINE, IL 60067-6976
PHONE: +1.847.359.2790
FAX: +1.847.359.6538
WEB: WWW.LUMEX.COM

4.3" ACTIVE MATRIX FULL COLOR TFT PANEL, 6:00 VIEW, LED BACKLIGHT, -20°C TO +70°C OPERATING TEMP.

THE SPECIFICATIONS MAY CHANGE AT ANY TIME WITHOUT NOTICE DUE TO NEW MATERIALS OR PRODUCT IMPROVEMENT.

CONFIDENTIAL INFORMATION
THE INFORMATION CONTAINED IN THIS DOCUMENT IS THE PROPERTY OF LUMEX INC. EXCEPT AS SPECIFICALLY AUTHORIZED IN WRITING BY LUMEX INC., THE HOLDER OF THIS DOCUMENT SHALL KEEP ALL INFORMATION CONTAINED HEREIN CONFIDENTIAL AND SHALL PROTECT SAME IN WHOLE OR IN PART FROM DISCLOSURE AND DISSEMINATION TO ALL THIRD PARTIES.

DATE:	06.25.09	DRAWN BY:	JN
PAGE:	2 OF 10	CHKD BY:	SS
SCALE:	NTS	APRVD BY:	SS
UNIT:	mm [INCH]		Ⓟ

PART NUMBER	LCT-H480272M43W1	REV.	A
DATE	E.C.N. NUMBER AND REVISION COMMENTS		REV.
06.09.11	E.C.N. #10BRDR.		A

ELECTRICAL CHARACTERISTICS

SYMBOL	CONDITION	CONDITION	MIN	TYP.	MAX	UNIT
VDDIO	POWER SUPPLY PIN OF IO PINS	RECOMENNDED OPERATING VOLTAGE POSSIBLE OPERATING VOLTAGE	1.8	-	3.6	V
VCI	BOOSTER REFERENCE SUPPLY VOLTAGE RANGE	RECOMENNDED OPERATING VOLTAGE POSSIBLE OPERATING VOLTAGE	$\geq VDDIO$ & ≥ 3	-	3.6	V
ISLEEP	SLEEP MODE CURRENT	-	-	50	-	uA
IDP	OPERATING MODE CURRENT	VCI=3.3V	-	13	15	mA
VCL	NEGATIVE VCI OUTPUT VOLTAGE	NO PANEL LOADING	-VCI	-	-VCI+0.7	V
VCIX2	VCIX2 PRIMARY BOOSTER EFFICIENCY(2)	NO PANEL LOADING, ITO FOR VCIX2, VCI	-	-	-	-
VDC	VDC OUTPUT VOLTAGE	VDC[3:0]=1011	4.9	5	5.1	V
VGH	GATE DRIVER HIGH OUTPUT VOLTAGE BOOSTER EFFICIENCY(2)	NO PANEL LOADING; 3X BOOSTER	84	89.5	-	%
		NO PANEL LOADING; 3X BOOSTER	80	88.5	-	%
VGL	GATE DRIVER LOW OUTPUT VOLTAGE	VGL = -2 X VDC	-10	-10	-9	V
COMH	VCOM HIGH OUTPUT VOLTAGE (3)	-	-3%	COMC +COMPP	3%	V
COML	VCOM LOW OUTPUT VOLTAGE (3)	-	-3%	COMC +COMPP	3%	V
VLCD	VLCD OUTPUT VOLTAGE	VRH[5:0]=100100	4.41	4.51	4.61	V
VOH1	LOGIC HIGH OUTPUT VOLTAGE	I OUT= -100uA	0.9*VDDIO	-	VDD	V
VDD	SOURCE OUTPUT VOLTAGE DEVIATION	-	-	± 20	± 30	mV
VOS	SOURCE OUTPUT VOLTAGE DEVIATION	-	-	-	± 30	mV
VOL1	LOGIC LOW OUTPUT VOLTAGE	I OUT= 100uA	0	-	0.1*VDDIO	V
VIH1	LOGIC HIGH INPUT VOLTAGE	-	0.9*VDDIO	-	VDDIO	V
VIL1	LOGIC LOW INPUT VOLTAGE	-	0	-	0.2*VDDIO	V
IOH	LOGIC HIGH OUTPUT CURRENT SOURCE	V OUT= VDD -0.4V	50	-	-	uA
IOL	LOGIC HIGH OUTPUT CURRENT DRAIN	V OUT= 0.4V	-	-	-50	uA
IOZ	LOGIC OUTPUT TRI-STATE CURRENT DRAIN SOURCE	-	-1	-	1	uA
IIL/I IH	LOGIC INTPUT CURRENT	-	-1	-	1	uA

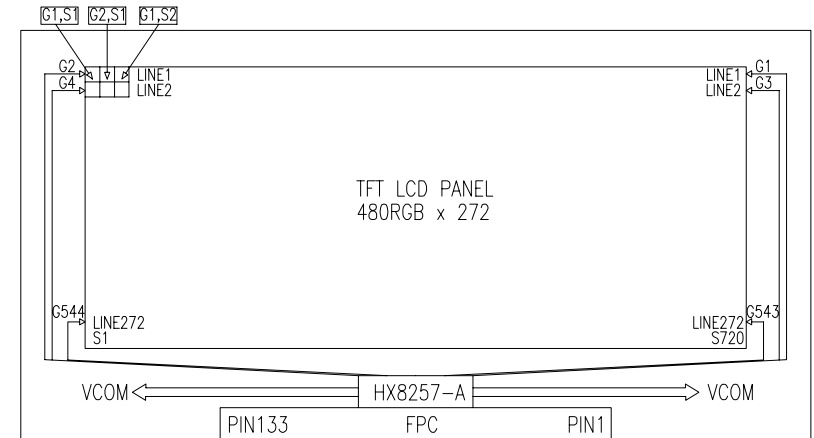

ABSOLUTE MAXIMUM RATINGS

ITEM	SYMBOL	UNIT	VALUE
POWER SUPPLY VOLTAGE (1)	VDD	V	-0.3 TO +0.8
POWER SUPPLY VOLTAGE (2)	VDC	V	-0.3 TO +0.8
POWER SUPPLY VOLTAGE (3)	VGH-VGL	V	-0.3 TO +0.8
POWER SUPPLY VOLTAGE (4)	VGH-VCL	V	-0.3 TO +0.8
OPERATING TEMPERATURE	TOP	°C	-20~70
STORAGE TEMPERATURE	TST	°C	-30~80

*UNLESS OTHERWISE SPECIFIED TOLERANCES PER DECIMAL PRECISION ARE: X=±1 (±0.039), X.X=±0.5 (±0.020), X.XX=±0.25 (±0.010), X.XXX=±0.127 (±0.005). LEAD SIZE=±0.05 (±0.002), LEAD LENGTH=±0.75 (±0.030). MIN= ^{+DECIMAL PRECISION} -0.00 MAX= ^{+DECIMAL PRECISION} -0.00

LUMEX
 Creating LED and LCD Solutions Together™
 290 E. HELEN ROAD
 PALATINE, IL 60067-6976
 PHONE: +1.847.359.2790
 FAX: +1.847.359.6538
 WEB: WWW.LUMEX.COM

4.3" ACTIVE MATRIX FULL COLOR TFT PANEL, 6:00 VIEW, LED BACKLIGHT, -20°C TO +70°C OPERATING TEMP.
 THE SPECIFICATIONS MAY CHANGE AT ANY TIME WITHOUT NOTICE DUE TO NEW MATERIALS OR PRODUCT IMPROVEMENT.
 CONFIDENTIAL INFORMATION
 THE INFORMATION CONTAINED IN THIS DOCUMENT IS THE PROPERTY OF LUMEX INC. EXCEPT AS SPECIFICALLY AUTHORIZED IN WRITING BY LUMEX INC., THE HOLDER OF THIS DOCUMENT SHALL KEEP ALL INFORMATION CONTAINED HEREIN CONFIDENTIAL AND SHALL PROTECT SAME IN WHOLE OR IN PART FROM DISCLOSURE AND DISSEMINATION TO ALL THIRD PARTIES.

DATE:	06.25.09	DRAWN BY:	JN
PAGE:	3 OF 10	CHKD BY:	SS
SCALE:	NTS	APRVD BY:	SS
UNIT:	mm [INCH]		Ⓟ

PART NUMBER	LCT-H480272M43W1	REV.	A
DATE	E.C.N. NUMBER AND REVISION COMMENTS		REV.
06.09.11	E.C.N. #10BRDR.		A

BACKLIGHT SPECIFICATIONS		LED BACKLIGHT ABSOLUTE MAXIMUM RATINGS (To=25°C)			
ITEM	SYMBOL	STANDARD VALUE			UNIT
		MIN	TYP.	MAX	
ABSOLUTE MAX FORWARD CURRENT	Ifm	-	-	-	mA
REVERSE VOLTAGE	Vr	-	-	-	V
OPERATING TEMPERATURE RANGE	TOPR	-	-	-	°C
STORAGE TEMPERATURE RANGE	TSTG	-	-	-	°C

BACKLIGHT SPECIFICATIONS		LED BACKLIGHT ELECTRO OPTICAL CHARACTERISTICS					
ITEM	SYMBOL	MIN	TYP.	MAX	UNIT	CONDITIONS	
FORWARD CURRENT	Vf	-	-	-	mA	If=30mA T=25°C	
REVERSE CURRENT	Ir	0	-	200	V		
CHROMATICITY COORDINATES	X	0.282	-	0.320	°C	Vr=10V	
	Y	0.276	-	0.330	°C		
LUMINANCE	Lv	2400	2600	3000	cd/m ²	MIN/MAX*100%	
UNIFORMITY	△	85%	-	-	%	MIN/MAX*100%	
LUMINANCE (TILL	-	20000	-	-	HOURS	If=15mA, Lv=2600cd/m ²	
HALF LUMMINANCE)	-	-	50000	-	HOURS	If=10mA, Lv=2200cd/m ²	

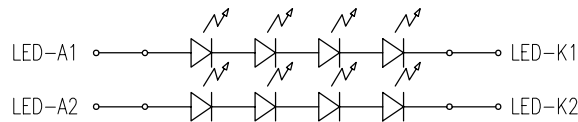

*UNLESS OTHERWISE SPECIFIED TOLERANCES PER DECIMAL PRECISION ARE: X=±1 (±0.039), X.X=±0.5 (±0.020), X.XX=±0.25 (±0.010), X.XXX=±0.127 (±0.005). LEAD SIZE=±0.05 (±0.002), LEAD LENGTH=±0.75 (±0.030). MIN= ^{+0.00}DECIMAL PRECISION MAX.= ^{-0.00}DECIMAL PRECISION

	290 E. HELEN ROAD PALATINE, IL 60067-6976 PHONE: +1.847.359.2790 FAX: +1.847.359.6538 WEB: WWW.LUMEX.COM	4.3" ACTIVE MATRIX FULL COLOR TFT PANEL, 6:00 VIEW, LED BACKLIGHT, -20°C TO +70°C OPERATING TEMP.		DATE: 06.25.09	DRAWN BY: JN
		THE SPECIFICATIONS MAY CHANGE AT ANY TIME WITHOUT NOTICE DUE TO NEW MATERIALS OR PRODUCT IMPROVEMENT.		PAGE: 4 OF 10	CHKD BY: SS
		CONFIDENTIAL INFORMATION THE INFORMATION CONTAINED IN THIS DOCUMENT IS THE PROPERTY OF LUMEX INC. EXCEPT AS SPECIFICALLY AUTHORIZED IN WRITING BY LUMEX INC., THE HOLDER OF THIS DOCUMENT SHALL KEEP ALL INFORMATION CONTAINED HEREIN CONFIDENTIAL AND SHALL PROTECT SAME IN WHOLE OR IN PART FROM DISCLOSURE AND DISSEMINATION TO ALL THIRD PARTIES.		SCALE: NTS	APRVD BY: SS
				UNIT: mm [INCH]	

PART NUMBER	LCT-H480272M43W1	REV.	A
DATE	E.C.N. NUMBER AND REVISION COMMENTS		REV.
06.09.11	E.C.N. #10BRDR.		A

OPTICAL CHARACTERISTICS							
ITEM	SYMBOL	CONDITION	STANDARD VALUE			UNIT	NOTE
			MIN	TYP.	MAX		
RESPONSE TIME	Tr	$\theta=0^{\circ}\text{C}$	-	5	-	V	1
	Tf		-	15	-	V	
CONTRAST RATIO	CR	25°C	-	250	-	V	2
VIEWING ANGLE (CR ≥ 10)	RIGHT	$\phi=0^{\circ}\text{C}$	-	45	-	DEG	3
	LEFT	$\phi=180^{\circ}\text{C}$	-	45	-	DEG	
	UPPER	$\phi=90^{\circ}\text{C}$	-	15	-	DEG	
	LOWER	$\phi=270^{\circ}\text{C}$	-	35	-	DEG	
LUMINANCE OF WHITE (CENTER POINT OF LCM)	L	-	200	250	-	Cd/m ²	5
TRANSMISIVE RATE	T%	-	-	6.1	-	%	4
COLOR CROMACITY (CIE1931)	Rx	$\theta=0^{\circ}\text{C}$	0.590	0.620	0.650	-	
	Ry		0.314	0.344	0.374	-	
Gx	0.276		0.306	0.336	-		
Gy	0.533		0.563	0.593	-		
Bx	0.103		0.133	0.163	-		
By	0.119		0.149	0.179	-		
Wx	0.281		0.311	0.341	-		
Wy	0.319		0.349	0.379	-		
OPTIMUM VIEWING DIRECTION	6 O'CLOCK						-

NOTE(1): DEFINITION OF RESPONSE TIME

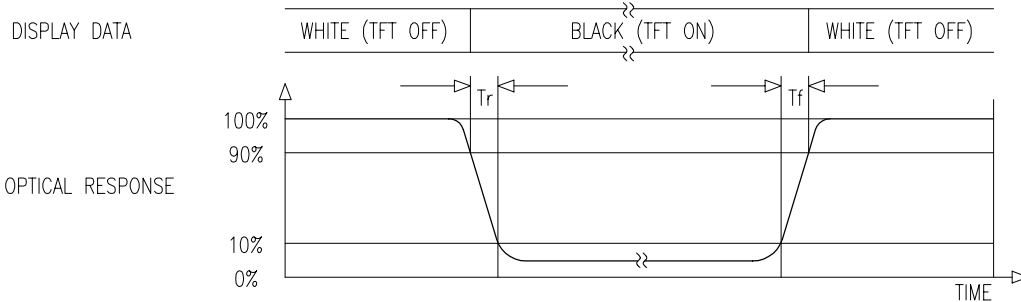

NOTE(2): DEFINITION OF CONTRAST RATIO
CR=BRIGHTNESS AT ALL PIXELS "WHITE" / BRIGHTNESS AT ALL PIXELS "BLACK"

NOTE(4): MEASURED AT CENTER POINT VERTICALLY WITH BACKLIGHT ON."

NOTE(3): DEFINITION OF VIEWING ANGLE

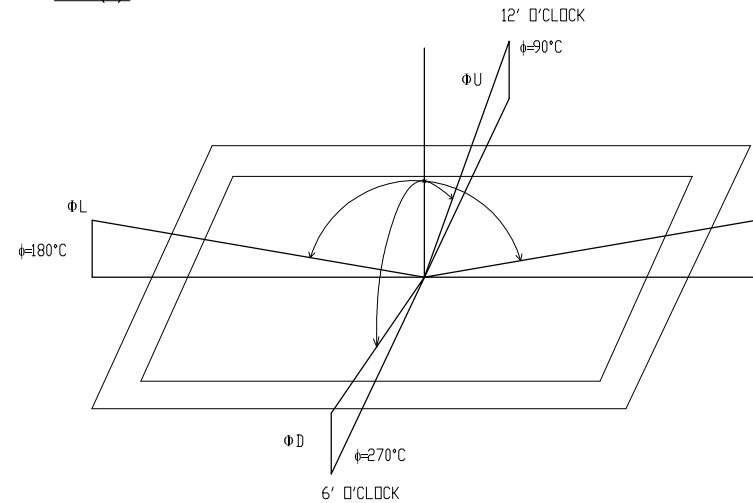

NOTE(5): AFTER STABILIZING AND LEAVING THE PANEL ALONE AT GIVEN TEMPERATURE FOR 30MIN, THE MEASUREMENT SHOULD BE EXECUTED. MEASUREMENT SHOULD BE EXECUTED IN STABLE, WINDLESS, AND DARK ROOM 30 MINS AFTER LIGHTING THE BACK-LIGHT. THIS SHOULD BE MEASURED IN THE CENTER OF SCREEN. ENVIRONMENT CONDITION: T_a=25±2°C BACK-LIGHT ON CONDITION

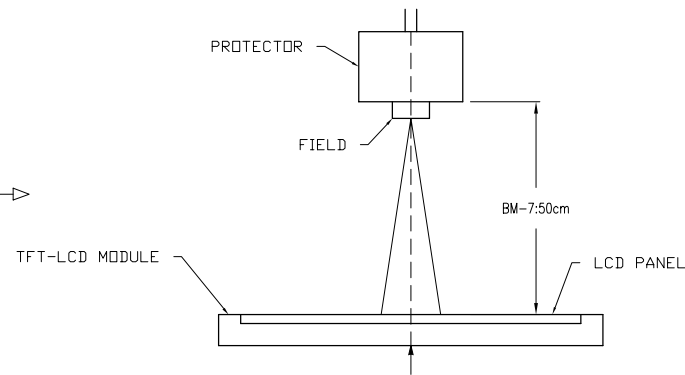

*UNLESS OTHERWISE SPECIFIED TOLERANCES PER DECIMAL PRECISION ARE: X=±1 (±0.039), X.X=±0.5 (±0.020), X.XX=±0.25 (±0.010), X.XXX=±0.127 (±0.005). LEAD SIZE=±0.05 (±0.002), LEAD LENGTH=±0.75 (±0.030). MIN= ^{+0.00}DECIMAL PRECISION MAX.= ^{-0.00}DECIMAL PRECISION

LUMEX
Creating LED and LCD Solutions Together™

290 E. HELEN ROAD
PALATINE, IL 60067-6976
PHONE: +1.847.359.2790
FAX: +1.847.359.6538
WEB: WWW.LUMEX.COM

4.3" ACTIVE MATRIX FULL COLOR TFT PANEL, 6:00 VIEW, LED BACKLIGHT, -20°C TO +70°C OPERATING TEMP.

THE SPECIFICATIONS MAY CHANGE AT ANY TIME WITHOUT NOTICE DUE TO NEW MATERIALS OR PRODUCT IMPROVEMENT.

CONFIDENTIAL INFORMATION
THE INFORMATION CONTAINED IN THIS DOCUMENT IS THE PROPERTY OF LUMEX INC. EXCEPT AS SPECIFICALLY AUTHORIZED IN WRITING BY LUMEX INC., THE HOLDER OF THIS DOCUMENT SHALL KEEP ALL INFORMATION CONTAINED HEREIN CONFIDENTIAL AND SHALL PROTECT SAME IN WHOLE OR IN PART FROM DISCLOSURE AND DISSEMINATION TO ALL THIRD PARTIES.

DATE:	06.25.09	DRAWN BY:	JN
PAGE:	5 OF 10	CHKD BY:	SS
SCALE:	NTS	APRVD BY:	SS
UNIT:	mm [INCH]		

PART NUMBER	LCT-H480272M43W1	REV.	A
DATE	E.C.N. NUMBER AND REVISION COMMENTS		REV.
06.09.11	E.C.N. #10BRDR.		A

STANDARD SPECIFICATION FOR REABILITY

STANDARD SPECIFICATION OF REABILITY TEST

NO	TEST ITEM	CONTENT OF TEST	TEST CONDITION	APPLICABLE STANDARD
1	HIGH TEMPERATURE STORAGE	ENDURANCE TEST APPLYING THE HIGH STORAGE TEMPERATURE FOR A LONG TIME.	80+/-3°C 240HRS	- - - -
2	LOW TEMPERATURE STORAGE	ENDURANCE TEST APPLYING THE HIGH STORAGE TEMPERATURE FOR A LONG TIME.	-30+/-3°C 240HRS	- - - -
3	HIGH TEMPERATURE OPERATION	ENDURANCE TEST APPLYING THE ELECTRIC STRESS (VOLTAGE & CURRENT) AND THE THERMAL STRESS TO THE ELEMENT FOR A LONG TIME.	70+/-3°C 240HRS	- - - -
4	LOW TEMPERATURE OPERATION	ENDURANCE TEST APPLYING THE ELECTRIC STRESS UNDER LOW TEMPERATURE FOR A LONG TIME.	-20+/-3°C 240HRS	- - - -
5	HIGH TEMPERATURE/HUMIDITY OPERATION	ENDURANCE TEST APPLYING THE ELECTRIC STRESS (VOLTAGE & CURRENT) AND TEMPERATURE / HUMIDITY STRESS TO THE ELEMENT FOR A LONG TIME.	40°C, 90%RH 120HRS	MIL-202E-103B JIS-C5023
6	TEMPERATURE CYCLE	ENDURANCE TEST APPLYING THE LOW AND HIGH TEMPERATURE CYCLE. $\begin{array}{c} -20^{\circ}\text{C} \quad \Rightarrow \quad 25^{\circ}\text{C} \quad \Rightarrow \quad 70^{\circ}\text{C} \\ \leftarrow 30 \text{ MIN} \quad \leftarrow \quad 5 \text{ MIN} \quad \leftarrow \quad 30 \text{ MIN} \quad \leftarrow \\ \text{1 CYCLE} \end{array}$	-20°C/ 70°C 10 CYCLES	- - - -
MECHANICAL TEST				
7	DROP TEST	ENDURANCE TEST APPLYING THE DROP DURING TRANSPORTATION.	PACKED,100cm FREE FALL(6 SLIDES, 1 CORNER, 3 EDGES)	- - - -

REMARKS:

1. FOR OPERATION TEST, ABOVE SPECIFICATION IS APPLICABLE WHEN TEST PATTERN IS CHANGING DURING ENTIRE OPERATION TEST.
2. INSPECTIONS AFTER RELIABILITY TESTS ARE PERFORMED WHEN THE DISPLAY TEMPERATURE RESUMES BACK TO ROOM TEMPERATURE.
3. IT IS A NORMAL CHARACTERISTIC THAT SOME DISPLAY ABNORMALITY CAN BE SEEN DURING REABILITY TEST. IF THE DISPLAY ABNORMALITY CAN RESUME BACK TO NORMAL CONDITION AT ROOM TEMPERATURE WITHIN 24 HOURS, THERE IS NO PERMANENT DESTRUCTION OVER THE DISPLAY. THE DISPLAY STILL POSSESSES ITS FUNCTIONALITY AFTER REABILITY TESTS.

*UNLESS OTHERWISE SPECIFIED TOLERANCES PER DECIMAL PRECISION ARE: X=±1 (±0.039), X.X=±0.5 (±0.020), X.XX=±0.25 (±0.010), X.XXX=±0.127 (±0.005). LEAD SIZE=±0.05 (±0.002), LEAD LENGTH=±0.75 (±0.030). MIN= ^{+0.00}DECIMAL PRECISION MAX.= ^{-0.00}DECIMAL PRECISION

 <p>290 E. HELEN ROAD PALATINE, IL 60067-6976 PHONE: +1.847.359.2790 FAX: +1.847.359.6538 WEB: WWW.LUMEX.COM</p>	<p>4.3" ACTIVE MATRIX FULL COLOR TFT PANEL, 6:00 VIEW, LED BACKLIGHT, -20°C TO +70°C OPERATING TEMP.</p> <p style="text-align: center;">**THE SPECIFICATIONS MAY CHANGE AT ANY TIME WITHOUT NOTICE DUE TO NEW MATERIALS OR PRODUCT IMPROVEMENT.**</p> <p style="text-align: center;">CONFIDENTIAL INFORMATION</p> <p style="text-align: center;">THE INFORMATION CONTAINED IN THIS DOCUMENT IS THE PROPERTY OF LUMEX INC. EXCEPT AS SPECIFICALLY AUTHORIZED IN WRITING BY LUMEX INC., THE HOLDER OF THIS DOCUMENT SHALL KEEP ALL INFORMATION CONTAINED HEREIN CONFIDENTIAL AND SHALL PROTECT SAME IN WHOLE OR IN PART FROM DISCLOSURE AND DISSEMINATION TO ALL THIRD PARTIES.</p>	DATE: 06.25.09	DRAWN BY: JN
		PAGE: 6 OF 10	CHKD BY: SS
		SCALE: NTS	APRVD BY: SS
		UNIT: mm [INCH]	(Pb)

PART NUMBER	LCT-H480272M43W1	REV.	A
DATE	E.C.N. NUMBER AND REVISION COMMENTS		REV.
06.09.11	E.C.N. #10BRDR.		A

QUALITY ASSURANCE

ACCEPTABLE QUALITY LEVEL (AQL)

EACH LOT SHOULD SATISFY THE QUALITY LEVEL DEFINED AS FOLLOWS:

- A. INSPECTION METHOD: MIL-SDT-105E LEVEL II NORMAL ONE TIME SAMPLING.
- B. AQL LEVEL.

CATEGORY	AQL	DEFINITION
MAJOR	0.25%	FUNCTIONAL DEFECTIVE AS PRODUCT.
MINOR	1.00%	SATIFY ALL FUNCTIONS AS PRODUCT BUT NOT SATISFY COSMETIC STANDARD.

COSMETIC SCREENING CRITERIA

NO	DEFECT	JUDGMENT CRITERIA	CATEGORY
1	SPOTS/DUST /BUBBLE (ROUND TYPE)	SIZE, D(mm) ACCEPTABLE QUANTITY IN ACTIVE AREA D≤0.15 DISREGARD 3 0.15<D≤0.20 0 D>0.20 0	MINOR
2	DUST/ SCRATCHES/ BLACK STREAK (LINE TYPE)	WIDTH, W(mm) LENGTH, L(mm) IN ACTIVE AREA W≤0.02 DISREGARD DISREGARD W≤0.03 L ≤ 1.0 DISREGARD W≤0.05 L ≤ 2.0 3 W>0.05 DISREGARD 0	MINOR
3	ALLOWABLE DENSITY	ABOVE DEFECTS SHOULD BE SEPARATED MORE THAN 5mm EACH OTHER.	MINOR
4	RAINBOW	OBVIOUS UNVEN COLOR (RAINBOW) SHALL NOT BE NOTICEABLE.	MINOR
5	DISPLAY CONDITION	DIM DISPLAY ON THE PATTERNS, EXTRA PATTERN AND SHORT CIRCUIT ARE NOT ACCEPTABLE.	MAJOR
6	NO DISPLAY OR MISSING DISPLAY	THE PATTERNS OF DISPLAY SHALL LIGHT UP AS REQUIRED. NO DISPLAY OR MISSING DISPLAY ARE NOT ACCEPTABLE.	MAJOR

NOTE: D= (LONG LENGTH + SORTH LENGTH)/2

FAILURE JUDGMENT CRITERIA

AFTER REABILITY TEST ABOVE, TEST SAMPLE SHALL BE LET RUN TO ROOM TEMPERATURE AND HUMIDITY AT LEAST 4 HOURS BEFORE FINAL TESTS ARE CARRIED OUT.

CRITERION ITEM	FAILURE JUDGMENT CRITERIA
ELECTRICAL CHARACTERISTIC	ELECTRICAL SHORT AND OPEN.
MECHANICAL CHARACTERISTIC	OUT OF MECHANICAL SPECIFICATION.
OPTICAL CHARACTERISTIC	OUT OF APPERANCE STANDARD.

*UNLESS OTHERWISE SPECIFIED TOLERANCES PER DECIMAL PRECISION ARE: X=±1 (±0.039), X,X=±0.5 (±0.020), X,XX=±0.25 (±0.010), X,XXX=±0.127 (±0.005). LEAD SIZE=±0.05 (±0.002), LEAD LENGTH=±0.75 (±0.030). MIN= ^{+0.00}DECIMAL PRECISION MAX.= ^{-0.00}DECIMAL PRECISION

 <p>290 E. HELEN ROAD PALATINE, IL 60067-6976 PHONE: +1.847.359.2790 FAX: +1.847.359.6538 WEB: WWW.LUMEX.COM</p>	<p>4.3" ACTIVE MATRIX FULL COLOR TFT PANEL, 6:00 VIEW, LED BACKLIGHT, -20°C TO +70°C OPERATING TEMP.</p> <p>**THE SPECIFICATIONS MAY CHANGE AT ANY TIME WITHOUT NOTICE DUE TO NEW MATERIALS OR PRODUCT IMPROVEMENT.**</p> <p>CONFIDENTIAL INFORMATION THE INFORMATION CONTAINED IN THIS DOCUMENT IS THE PROPERTY OF LUMEX INC. EXCEPT AS SPECIFICALLY AUTHORIZED IN WRITING BY LUMEX INC., THE HOLDER OF THIS DOCUMENT SHALL KEEP ALL INFORMATION CONTAINED HEREIN CONFIDENTIAL AND SHALL PROTECT SAME IN WHOLE OR IN PART FROM DISCLOSURE AND DISSEMINATION TO ALL THIRD PARTIES.</p>	DATE: 06.25.09	DRAWN BY: JN
		PAGE: 7 OF 10	CHKD BY: SS
		SCALE: NTS	APRVD BY: SS
		UNIT: mm [INCH]	Ⓟ

PART NUMBER	LCT-H480272M43W1	REV.	A
DATE	E.C.N. NUMBER AND REVISION COMMENTS		REV.
06.09.11	E.C.N. #10BRDR.		A

PRECAUTIONS FOR USING LCD MODULE

HANDLING PRECAUTIONS

1. THE DISPLAY PANEL IS MADE OF GLASS AND POLARIZER. DO NOT SUBJECT IT TO MECHANICAL SHOCK BY DROPPING OR IMPACT WHICH MAY CAUSE CHIPPING ESPECIALLY ON THE EDGES.
2. DO NOT TOUCH, PUSH OR RUB THE EXPOSED POLARIZERS WITH ANYTHING HARDER THAN AN HB PENCIL LEAD (GLASS, TWEEZERS, ETC.). THE POLARIZER COVERING THE DISPLAY SURFACE OF THE LCD MODULE IS SOFT AND EASILY SCRATCHED. HANDLE THIS POLARIZER CAREFULLY.
3. IF THE DISPLAY SURFACE BECOMES CONTAMINATED, BREATHE ON THE SURFACE AND GENTLY WIPE IT WITH A SOFT DRY CLOTH. IF IT IS HEAVILY CONTAMINATED, MOISTEN CLOTH WITH ISOPROPYL ALCOHOL OR ETHYL ALCOHOL. AVOID USING SOLVENTS LIKE ACETONE (KETENE), WATER, TOLUENE, ETHANOL TO CLEAN THE POLARIZER SURFACE.
4. PLEASE KEEP THE TEMPERATURE WITHIN SPECIFIED RANGE FOR USE AND STORAGE. POLARIZATION DEGRADATION, BUBBLE GENERATION OR POLARIZER PEEL-OFF MAY OCCUR WITH HIGH TEMPERATURE AND HIGH HUMIDITY.
5. DO NOT APPLY EXCESSIVE FORCE TO THE DISPLAY SURFACE OR THE ADJOINING AREAS SINCE THIS MAY CAUSE THE COLOR TONE TO VARY.
6. INSTALL THE LCD MODULE BY USING THE MOUNTING HOLES. WHEN MOUNTING THE LCD MODULE MAKE SURE IT IS FREE OF TWISTING, WRAPING AND DISTORTION.
7. EXERCISE CARE TO MINIMIZE CORROSION OF THE ELECTRODE. CORROSION OF THE ELECTRODES IS ACCELERATED BY WATER DROPLETS, MOISTURE CONDENSATION OR A CURRENT FLOW IN A HIGH-HUMIDITY ENVIRONMENT.
8. NC TERMINAL SHOULD BE OPEN. DO NOT CONNECT ANYTHING.
9. IF THE LOGIC CIRCUIT POWER IS OFF, DO NOT APPLY THE INPUT SIGNALS.
10. AVOID CONTACTING OIL AND FATS.
11. CONDENSATION ON THE SURFACE AND CONTACT WITH TERMINALS DUE TO COLD WILL DAMAGE, STAIN OR DIRTY THE POLARIZERS. AFTER PRODUCTS ARE TESTED AT LOW TEMPERATURE THEY MUST BE WARMED UP IN A CONTAINER BEFORE COMING IN CONTACT WITH ROOM TEMPERATURE AIR.
12. WIPE OFF SALIVA OR WATER DROPS IMMEDIATELY, CONTACT WITH WATER OVER A LONG PERIOD OF TIME MAY CAUSE DEFORMATION OR COLOR FADING.

ELECTRO-STATIC DISCHARGE CONTROL

1. SINCE THIS MODULE USES A CMOS LSI, THE SAME CAREFUL ATTENTION SHOULD BE PAID TO ELECTROSTATIC DISCHARGE AS FOR AN ORDINARY CMOS IC.
2. BE SURE TO GROUND THE BODY WHEN HANDLING THE LCD MODULES. TOOLS REQUIRED FOR ASSEMBLING, SUCH AS SOLDERING IRONS, MUST BE PROPERLY GROUNDED.
3. TO REDUCE THE AMOUNT OF STATIC ELECTRICITY GENERATED, DO NOT CONDUCT ASSEMBLING AND OTHER WORK UNDER DRY CONDITIONS. TO REDUCE THE GENERATION OF STATIC ELECTRICITY, BE CAREFUL THAT THE AIR IN THE WORK IS NOT TOO DRIED. A RELATIVE HUMIDITY OF 50%-60% IS RECOMMENDED.
4. THE LCD MODULE IS COATED WITH A FILM TO PROTECT THE DISPLAY SURFACE. EXERCISE CARE WHEN PEELING OFF THIS PROTECTIVE FILM SINCE STATIC ELECTRICITY MAY BE GENERATED.
5. WHEN SOLDERING THE TERMINAL OF LCM, MAKE CERTAIN THE AC POWER SOURCE FOR THE SOLDERING IRON DOES NOT LEAK.

PRECAUTION OF SOLDERING TO THE LCM

1. OBSERVE THE FOLLOWING WHEN SOLDERING LEAD WIRE, CONNECTOR CABLE AND ETC. TO THE LCD MODULE.

- SOLDERING IRON TEMPERATURE: 300~350°C.
- SOLDERING TIME: ≤ 3 SEC.
- SOLDER: EUTECTIC SOLDER.

ABOVE IS A RECOMMENDED APPROACH. DUE TO DIFFERENT SOLDER COMPOSITION AND PROCESSING METHOD, IT IS RECOMMENDED THAT CUSTOMER TO STUDY AND FINE TUNING THEIR SOLDERING PROCESS PARAMETERS ACCORDINGLY.

2. IF SOLDERING FLUX IS USED, BE SURE TO REMOVE ANY REMAINING FLUX AFTER FINISHING TO SOLDERING OPERATION. (THIS DOES NOT APPLY IN THE CASE OF A NON-HALOGEN TYPE OF FLUX.) IT IS RECOMMENDED THAT YOU PROTECT THE LCD SURFACE WITH A COVER DURING SOLDERING TO PREVENT ANY DAMAGE DUE TO FLUX SPATTERS.

PRECAUTION FOR OPERATION

1. VIEWING ANGLE VARIES WITH THE CHANGE OF LIQUID CRYSTAL DRIVING VOLTAGE (V_0). ADJUST V_0 TO SHOW THE BEST CONTRAST.
2. DRIVING THE LCD IN THE VOLTAGE ABOVE THE LIMIT SHORTENS ITS LIFETIME.
3. RESPONSE TIME IS GREATLY DELAYED AT TEMPERATURE BELOW THE OPERATING TEMPERATURE RANGE. HOWEVER, IT WILL RECOVER WHEN IT RETURNS TO THE SPECIFIED TEMPERATURE RANGE.
4. IF THE DISPLAY AREA IS PUSHED HARD DURING OPERATION, THE DISPLAY WILL BECOME ABNORMAL. HOWEVER, IT WILL RETURN TO NORMAL IF IT IS TURNED OFF AND THEN BACK ON.
5. WHEN TURNING THE POWER ON, INPUT EACH SIGNAL AFTER THE POSITIVE/NEGATIVE VOLTAGE BECOMES STABLE (BELOW FIGURE IS A GENERAL ILLUSTRATION WHERE TYPICAL VALUE DEPENDS ON INDIVIDUAL PRODUCT DESIGN).

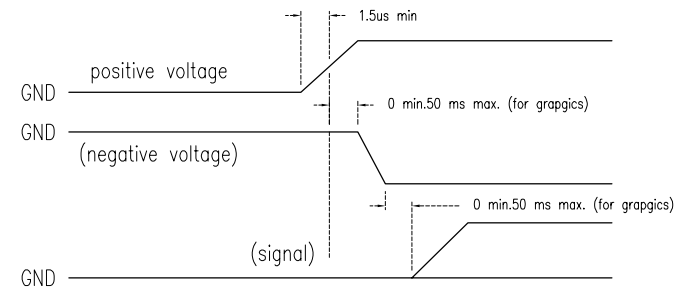

*UNLESS OTHERWISE SPECIFIED TOLERANCES PER DECIMAL PRECISION ARE: X=±1 (±0.039), X.X=±0.5 (±0.020), X.XX=±0.25 (±0.010), X.XXX=±0.127 (±0.005). LEAD SIZE=±0.05 (±0.002), LEAD LENGTH=±0.75 (±0.030). MIN.= ^{+0.00}DECIMAL PRECISION MAX.= ^{-0.00}DECIMAL PRECISION

UNCONTROLLED DOCUMENT



290 E. HELEN ROAD
PALATINE, IL 60067-6976
PHONE: +1.847.359.2790
FAX: +1.847.359.6538
WEB: WWW.LUMEX.COM

4.3" ACTIVE MATRIX FULL COLOR TFT PANEL, 6:00 VIEW, LED BACKLIGHT, -20°C TO +70°C OPERATING TEMP.

THE SPECIFICATIONS MAY CHANGE AT ANY TIME WITHOUT NOTICE DUE TO NEW MATERIALS OR PRODUCT IMPROVEMENT.

CONFIDENTIAL INFORMATION
THE INFORMATION CONTAINED IN THIS DOCUMENT IS THE PROPERTY OF LUMEX INC. EXCEPT AS SPECIFICALLY AUTHORIZED IN WRITING BY LUMEX INC., THE HOLDER OF THIS DOCUMENT SHALL KEEP ALL INFORMATION CONTAINED HEREIN CONFIDENTIAL AND SHALL PROTECT SAME IN WHOLE OR IN PART FROM DISCLOSURE AND DISSEMINATION TO ALL THIRD PARTIES.

DATE:	06.25.09	DRAWN BY:	JN
PAGE:	8 OF 10	CHKD BY:	SS
SCALE:	NTS	APRVD BY:	SS
UNIT:	mm [INCH]		Ⓟ

PART NUMBER	LCT-H480272M43W1	REV.	A
DATE	E.C.N. NUMBER AND REVISION COMMENTS		REV.
06.09.11	E.C.N. #10BRDR.		A

RoHS COMPLIANT PRODUCT

1. CADMIUM AND CADMIUM COMPOUNDS	LESS THAN 100PPM
2. HEXAVALENT CHROMIUM COMPOUNDS	LESS THAN 1000PPM
3. LEAD AND LEAD COMPOUNDS	LESS THAN 1000PPM
4. MERCURY AND MERCURY COPMPOUNDS	LESS THAN 1000PPM
5. POLYBROMINATED BIPHENYLS (PBBs)	LESS THAN 1000PPM
6. POLYBROMINATED DIPHENYL ETHERS (PBDEs)	LESS THAN 1000PPM

PACKAGING STANDARD

PRODUCT NO.	LCT-H480272M43W	RELEASE DATE	04/APR. 2007
PRODUCT NAME.	TFT MODULE	PREPARE BY:	
QUANTITY/ EACH BOX	96 PCS.	BOX MATERIAL	PAPER CARTON
OUTER CARTON BOX SIZE	465mm x 405mm x 305mm	BOX TYPE	NEW
QUANTITY/ INNER BOX	-	WEIGHT	KG
QUANTITY/ OUTER BOX			

THERE ARE 12 PCS LCD PER EACH ANTI-STATIC PLASTIC PLATE.
THERE ARE 7 LAYER PLASTIC PLATES PER EACH INNER CARTON BOX.
THERE ARE 2 INNER CARTON BOX PER EACH OUTER CARTON BOX.

STORAGE

1. WHEN STORING LCDS AS SPARES FOR SOME YEARS, THE FOLLOWING PRECAUTIONS ARE NECESSARY.
2. STORE THEM IN A SEALED POLYETHYLENE BAG. IF PROPERLY SEALED, THERE IS NO NEED FOR DESICCANT.
3. STORE THEM IN A DARK PLACE. DO NOT EXPOSE TO SUNLIGHT OR FLUORESCENT LIGHT, KEEP THE TEMPERATURE BETWEEN 0°C AND 35°C.
4. ENVIRONMENTAL CONDITIONS:
5. DO NOT LEAVE THEM FOR MORE THAN 168HRS. AT 60°C.
6. SHOULD NOT BE LEFT FOR MORE THAN 48HRS. AT -20°C.

SAFETY

1. ITS RECOMMENDED TO CRUSH DAMAGED OR UNNECESSARY LCD INTO PIECES AND WASH THEM OFF WITH SOLVENTS SUCH AS ACETONE AND ETHANOL, WHICH SHOULD LATER BE BURNED.
2. IF ANY LIQUID LEAKS OUT OF DAMAGED GLASS CELL AND COMES IN CONTACT WITH THE HANDS, WASH OFF THOROUGHLY WITH SOAP AND WATER.

*UNLESS OTHERWISE SPECIFIED TOLERANCES PER DECIMAL PRECISION ARE: X=±1 (±0.039), X.X=±0.5 (±0.020), X.XX=±0.25 (±0.010), X.XXX=±0.127 (±0.005). LEAD SIZE=±0.05 (±0.002), LEAD LENGTH=±0.75 (±0.030). MIN.= ^{+DECIMAL PRECISION} _{-0.00} MAX.= ^{+0.00} _{-DECIMAL PRECISION}

UNCONTROLLED DOCUMENT

 <p>290 E. HELEN ROAD PALATINE, IL 60067-6976 PHONE: +1.847.359.2790 FAX: +1.847.359.6538 WEB: WWW.LUMEX.COM</p>	<p>4.3" ACTIVE MATRIX FULL COLOR TFT PANEL, 6:00 VIEW, LED BACKLIGHT, -20°C TO +70°C OPERATING TEMP.</p> <p>**THE SPECIFICATIONS MAY CHANGE AT ANY TIME WITHOUT NOTICE DUE TO NEW MATERIALS OR PRODUCT IMPROVEMENT.**</p> <p>CONFIDENTIAL INFORMATION THE INFORMATION CONTAINED IN THIS DOCUMENT IS THE PROPERTY OF LUMEX INC. EXCEPT AS SPECIFICALLY AUTHORIZED IN WRITING BY LUMEX INC., THE HOLDER OF THIS DOCUMENT SHALL KEEP ALL INFORMATION CONTAINED HEREIN CONFIDENTIAL AND SHALL PROTECT SAME IN WHOLE OR IN PART FROM DISCLOSURE AND DISSEMINATION TO ALL THIRD PARTIES.</p>	DATE: 06.25.09	DRAWN BY: JN
		PAGE: 9 OF 10	CHKD BY: SS
		SCALE: NTS	APRVD BY: SS
		UNIT: mm [INCH]	Ⓟ

PART NUMBER	LCT-H480272M43W1	REV.	A
DATE	E.C.N. NUMBER AND REVISION COMMENTS		REV.
06.09.11	E.C.N. #10BRDR.		A

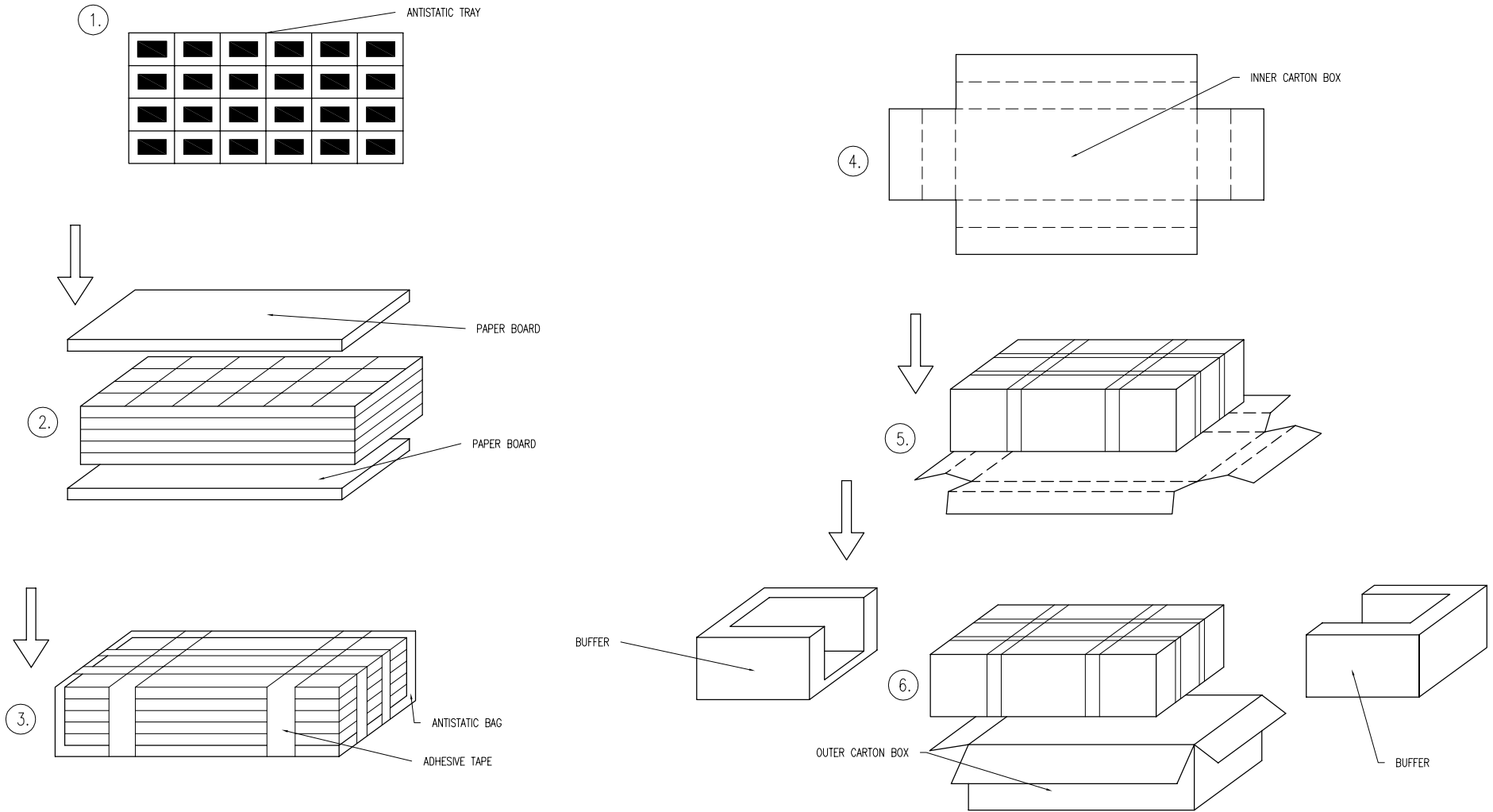

*UNLESS OTHERWISE SPECIFIED TOLERANCES PER DECIMAL PRECISION ARE: X=±1 (±0.039), X,X=±0.5 (±0.020), X,XX=±0.25 (±0.010), X,XXX=±0.127 (±0.005). LEAD SIZE=±0.05 (±0.002), LEAD LENGTH=±0.75 (±0.030). MIN.= ^{+DECIMAL PRECISION} _{-0.00} MAX.= ^{+0.00} _{-DECIMAL PRECISION} UNCONTROLLED DOCUMENT

LUMEX
 Creating LED and LCD Solutions Together™

290 E. HELEN ROAD
 PALATINE, IL 60067-6976
 PHONE: +1.847.359.2790
 FAX: +1.847.359.6538
 WEB: WWW.LUMEX.COM

4.3" ACTIVE MATRIX FULL COLOR TFT PANEL, 6:00 VIEW, LED BACKLIGHT, -20°C TO +70°C OPERATING TEMP.

THE SPECIFICATIONS MAY CHANGE AT ANY TIME WITHOUT NOTICE DUE TO NEW MATERIALS OR PRODUCT IMPROVEMENT.

CONFIDENTIAL INFORMATION
 THE INFORMATION CONTAINED IN THIS DOCUMENT IS THE PROPERTY OF LUMEX INC. EXCEPT AS SPECIFICALLY AUTHORIZED IN WRITING BY LUMEX INC., THE HOLDER OF THIS DOCUMENT SHALL KEEP ALL INFORMATION CONTAINED HEREIN CONFIDENTIAL AND SHALL PROTECT SAME IN WHOLE OR IN PART FROM DISCLOSURE AND DISSEMINATION TO ALL THIRD PARTIES.

DATE:	06.25.09	DRAWN BY:	JN
PAGE:	10 OF 10	CHKD BY:	SS
SCALE:	NTS	APRVD BY:	SS
UNIT:	mm [INCH]		Ⓟ