



Chipsmall Limited consists of a professional team with an average of over 10 year of expertise in the distribution of electronic components. Based in Hongkong, we have already established firm and mutual-benefit business relationships with customers from,Europe,America and south Asia,supplying obsolete and hard-to-find components to meet their specific needs.

With the principle of "Quality Parts,Customers Priority,Honest Operation,and Considerate Service",our business mainly focus on the distribution of electronic components. Line cards we deal with include Microchip,ALPS,ROHM,Xilinx,Pulse,ON,Everlight and Freescale. Main products comprise IC,Modules,Potentiometer,IC Socket,Relay,Connector.Our parts cover such applications as commercial,industrial, and automotives areas.

We are looking forward to setting up business relationship with you and hope to provide you with the best service and solution. Let us make a better world for our industry!



## Contact us

Tel: +86-755-8981 8866 Fax: +86-755-8427 6832

Email & Skype: info@chipsmall.com Web: www.chipsmall.com

Address: A1208, Overseas Decoration Building, #122 Zhenhua RD., Futian, Shenzhen, China



## 1.5 A, very low drop voltage regulators

Datasheet - production data

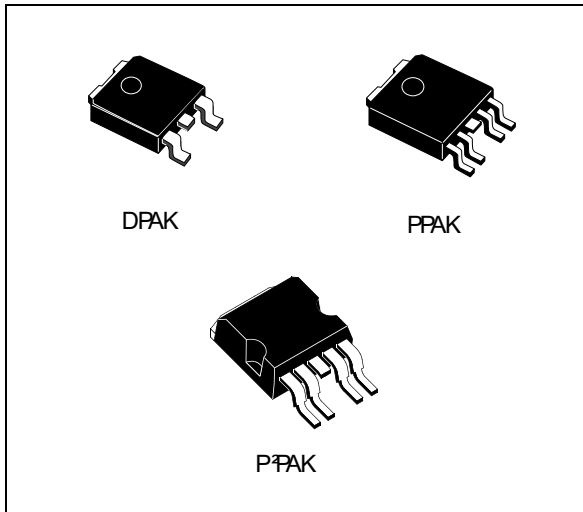

### Description

The LD29150 is a high current, high accuracy, low-dropout voltage regulator series. These regulators feature 400 mV dropout voltage and very low ground current. Designed for high current loads, these devices are also used in lower current, extremely low dropout-critical systems, where their tiny dropout voltage and ground current values are important attributes. Typical applications are in power supply switching post regulation, series power supply for monitors, series power supply for VCRs and TVs, computer systems and battery powered systems.

### Features

- Very low dropout voltage (typ. 0.4 at 1.5 A)
- Guaranteed output current up to 1.5 A
- Fixed and adjustable output voltage ( $\pm 1\%$  at 25 °C)
- Internal current and thermal limit
- Logic controlled electronic shutdown available in PPAK and P<sup>2</sup>PAK

**Table 1. Device summary**

Order codes			Output voltages
DPAK	PPAK	P <sup>2</sup> PAK	
LD29150DT18R			1.8 V
LD29150DT25R			2.5 V
LD29150DT33R		LD29150P2T33R	3.3 V
LD29150DT50R	LD29150PT50R		5.0 V
	LD29150PTR		ADJ

---

# Contents

1	Diagram .....	3
2	Pin configuration .....	4
3	Typical application .....	5
4	Maximum ratings .....	6
5	Electrical characteristics .....	7
6	Typical characteristics .....	12
7	Package mechanical data .....	15
8	Packaging mechanical data .....	23
9	Revision history .....	26

# 1 Diagram

Figure 1. Schematic diagram for adjustable version

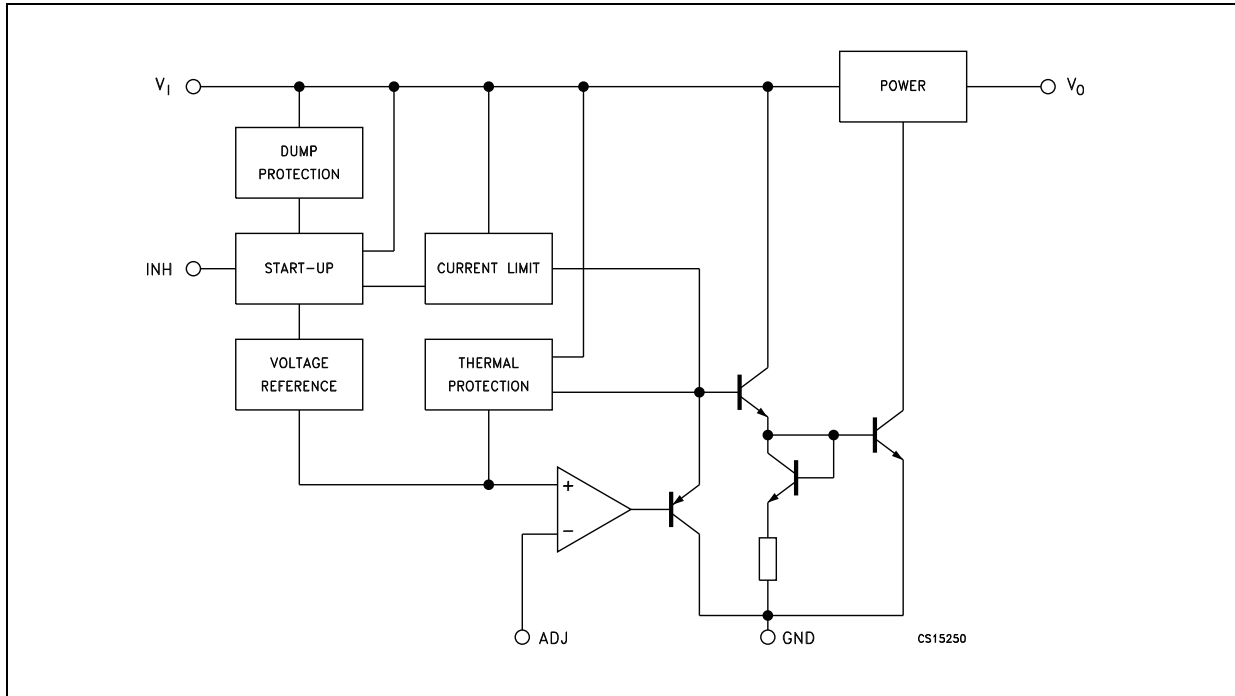
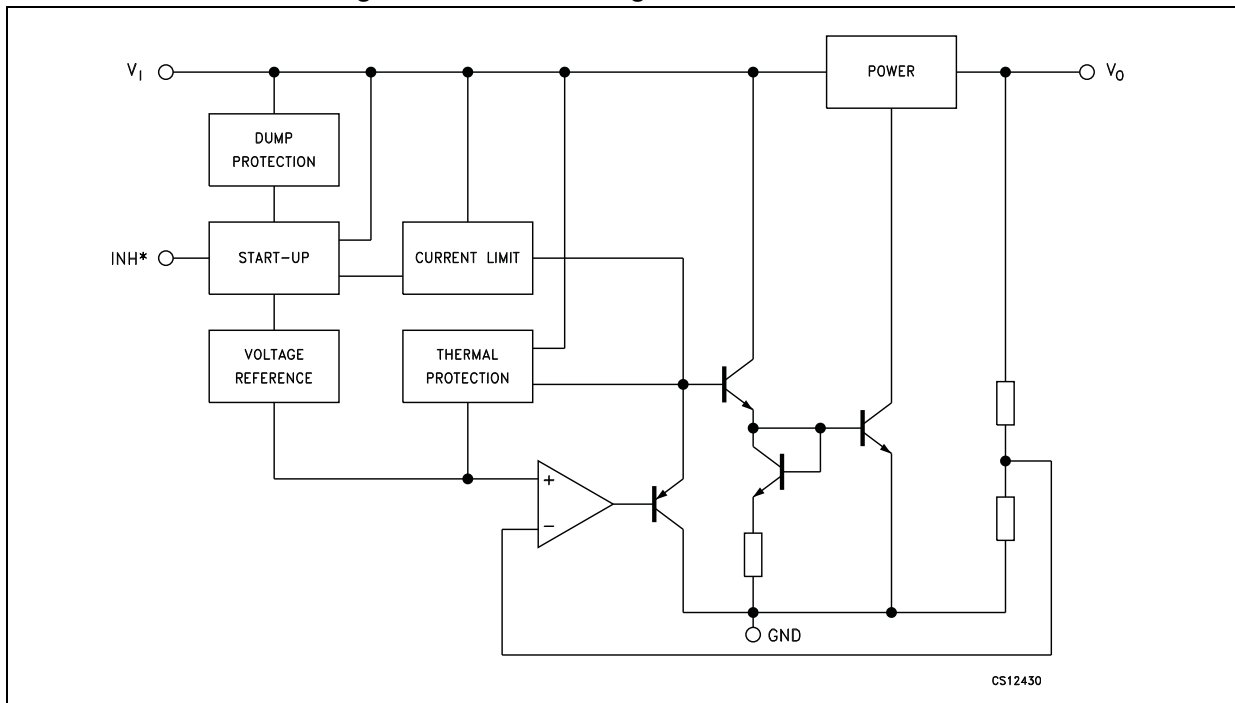

Figure 2. Schematic diagram for fixed version



\* Only for version with inhibit function.

## 2 Pin configuration

Figure 3. Pin connections (top view)

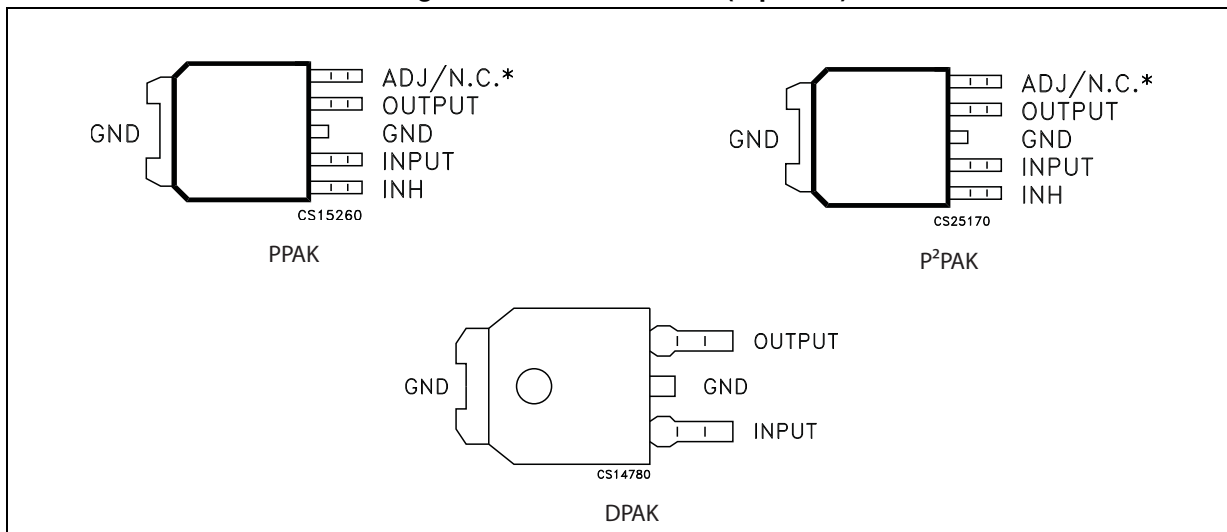

\* Not connected for fixed version.

### 3 Typical application

Figure 4. Application circuit

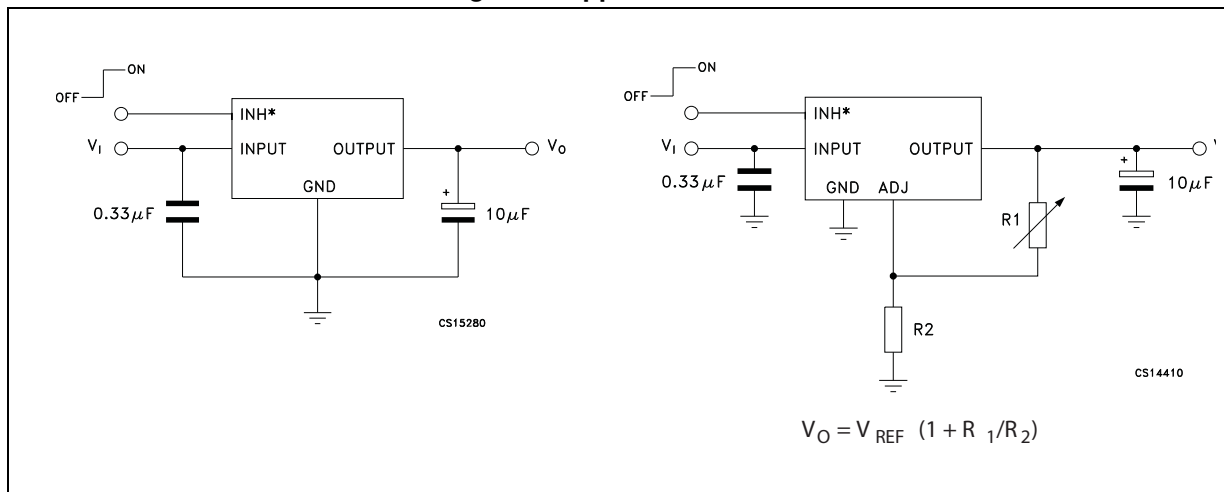

\* Only for version with inhibit function.

## 4 Maximum ratings

**Table 2. Absolute maximum ratings**

Symbol	Parameter	Value	Unit
$V_I$	DC input voltage	30 <sup>(1)</sup>	V
$V_O$	DC output voltage	-0.3 to 20	V
$V_{INH}$	Inhibit input voltage	-0.3 to 20	V
$I_O$	Output current	Internally limited	mA
$P_D$	Power dissipation	Internally limited	mW
$T_{STG}$	Storage temperature range	-55 to 150	°C
$T_{OP}$	Operating junction temperature range	-40 to 125	°C

1. Above 14 V the device is automatically in shut-down.

*Note: Absolute maximum ratings are those values beyond which damage to the device may occur. Functional operation under these conditions is not implied.*

**Table 3. Thermal data**

Symbol	Parameter	DPAK	PPAK	P <sup>2</sup> PAK	Unit
$R_{thJA}$	Thermal resistance junction-ambient	100	100	60	°C/W
$R_{thJC}$	Thermal resistance junction-case	8	8	3	°C/W

## 5 Electrical characteristics

$I_O = 10 \text{ mA}$ ,  $T_J = 25 \text{ °C}$ ,  $V_I = 3.8 \text{ V}$ ,  $V_{INH} = 2 \text{ V}$  (*Note 3*),  $C_I = 330 \text{ nF}$ ,  $C_O = 10 \text{ μF}$ , unless otherwise specified.

**Table 4. Electrical characteristics of LD29150#18**

Symbol	Parameter	Test conditions	Min.	Typ.	Max.	Unit
$V_O$	Output voltage	$I_O = 10 \text{ mA to } 1.5 \text{ A}$ , $V_I = 3 \text{ to } 7.3 \text{ V}$ $T_J = -40 \text{ to } 125 \text{ °C}$	1.782	1.8	1.818	V
			1.764		1.836	
$\Delta V_O$	Load regulation	$I_O = 10 \text{ mA to } 1.5 \text{ A}$		0.2	1.0	%
$\Delta V_O$	Line regulation	$V_I = 3 \text{ to } 13 \text{ V}$		0.06	0.5	%
SVR	Supply voltage rejection	$f = 120 \text{ Hz}$ , $V_I = 3.8 \pm 1 \text{ V}$ , $I_O = 0.75 \text{ A}$ ( <i>Note 1</i> )	62	72		dB
$V_{DROPP}$	Dropout voltage	$I_O = 250 \text{ mA}$ , $T_J = -40 \text{ to } 125 \text{ °C}$ ( <i>Note 2</i> )		0.1		V
		$I_O = 0.75 \text{ A}$ , $T_J = -40 \text{ to } 125 \text{ °C}$ ( <i>Note 2</i> )		0.2		
		$I_O = 1.5 \text{ A}$ , $T_J = -40 \text{ to } 125 \text{ °C}$ ( <i>Note 2</i> )		0.4	0.7	
$I_q$	Quiescent current	$I_O = 0.75 \text{ A}$ , $T_J = -40 \text{ to } 125 \text{ °C}$		15	40	mA
		$I_O = 1.5 \text{ A}$ , $T_J = -40 \text{ to } 125 \text{ °C}$		30	80	
		$V_I = 13 \text{ V}$ , $V_{INH} = \text{GND}$ , $T_J = -40 \text{ to } 125 \text{ °C}$		130	180	$\mu\text{A}$
$I_{sc}$	Short circuit current	$V_I - V_O = 5.5 \text{ V}$		2.2		A
$V_{IL}$	Control input logic low	OFF MODE, ( <i>Note 3</i> ), $T_J = -40 \text{ to } 125 \text{ °C}$			0.8	V
$V_{IH}$	Control input logic high	ON MODE, ( <i>Note 3</i> ), $T_J = -40 \text{ to } 125 \text{ °C}$	2			V
$I_{INH}$	Control input current	$T_J = -40 \text{ to } 125 \text{ °C}$ , $V_{INH} = 13 \text{ V}$		5	10	$\mu\text{A}$
eN	Output noise voltage	$B_P = 10 \text{ Hz to } 100 \text{ kHz}$ , $I_O = 100 \text{ mA}$ ( <i>Note 1</i> )		72		$\mu\text{V}_{RMS}$
$T_{SHDN}$	Thermal shutdown			150		$^{\circ}\text{C}$

Note: 1 Guaranteed by design.

2 Dropout voltage is defined as the input-to-output differential when the output voltage drops to 99 % of its nominal value with  $V_O + 1 \text{ V}$  applied to  $V_I$ .

3 Only for version with Inhibit function.



$I_O = 10 \text{ mA}$ ,  $T_J = 25 \text{ °C}$ ,  $V_I = 4.5 \text{ V}$ ,  $V_{INH} = 2 \text{ V}$  (*Note 3*),  $C_I = 330 \text{ nF}$ ,  $C_O = 10 \text{ }\mu\text{F}$ , unless otherwise specified.

**Table 5. Electrical characteristics of LD29150#25**

Symbol	Parameter	Test conditions	Min.	Typ.	Max.	Unit
$V_O$	Output voltage	$I_O = 10 \text{ mA to } 1.5 \text{ A}$ , $V_I = 3.5 \text{ to } 8 \text{ V}$ $T_J = -40 \text{ to } 125 \text{ °C}$	2.475	2.5	2.525	V
			2.45		2.55	
$\Delta V_O$	Load regulation	$I_O = 10 \text{ mA to } 1.5 \text{ A}$		0.2	1.0	%
$\Delta V_O$	Line regulation	$V_I = 3.5 \text{ to } 13 \text{ V}$		0.06	0.5	%
SVR	Supply voltage rejection	$f = 120 \text{ Hz}$ , $V_I = 4.5 \pm 1 \text{ V}$ , $I_O = 0.75 \text{ A}$ ( <i>Note 1</i> )	55	70		dB
$V_{DROPO}$	Dropout voltage	$I_O = 250 \text{ mA}$ , $T_J = -40 \text{ to } 125 \text{ °C}$ ( <i>Note 2</i> )		0.1		V
		$I_O = 0.75 \text{ A}$ , $T_J = -40 \text{ to } 125 \text{ °C}$ ( <i>Note 2</i> )		0.2		
		$I_O = 1.5 \text{ A}$ , $T_J = -40 \text{ to } 125 \text{ °C}$ ( <i>Note 2</i> )		0.4	0.7	
$I_q$	Quiescent current	$I_O = 0.75 \text{ A}$ , $T_J = -40 \text{ to } 125 \text{ °C}$		15	40	mA
		$I_O = 1.5 \text{ A}$ , $T_J = -40 \text{ to } 125 \text{ °C}$		30	80	
		$V_I = 13 \text{ V}$ , $V_{INH} = \text{GND}$ , $T_J = -40 \text{ to } 125 \text{ °C}$		130	180	$\mu\text{A}$
$I_{sc}$	Short circuit current	$V_I - V_O = 5.5 \text{ V}$		2.2		A
$V_{IL}$	Control input logic low	OFF MODE, ( <i>Note 3</i> ), $T_J = -40 \text{ to } 125 \text{ °C}$			0.8	V
$V_{IH}$	Control input logic high	ON MODE, ( <i>Note 3</i> ), $T_J = -40 \text{ to } 125 \text{ °C}$	2			V
$I_{INH}$	Control input current	$T_J = -40 \text{ to } 125 \text{ °C}$ , $V_{INH} = 13 \text{ V}$		5	10	$\mu\text{A}$
eN	Output noise voltage	$B_P = 10 \text{ Hz to } 100 \text{ kHz}$ , $I_O = 100 \text{ mA}$ ( <i>Note 1</i> )		100		$\mu\text{V}_{RMS}$
$T_{SHDN}$	Thermal shutdown			150		$^{\circ}\text{C}$

Note: 1 Guaranteed by design.

2 Dropout voltage is defined as the input-to-output differential when the output voltage drops to 99% of its nominal value with  $V_O + 1 \text{ V}$  applied to  $V_I$ .

3 Only for version with Inhibit function.

$I_O = 10 \text{ mA}$ ,  $T_J = 25 \text{ °C}$ ,  $V_I = 5.3 \text{ V}$ ,  $V_{INH} = 2 \text{ V}$  (*Note 3*),  $C_I = 330 \text{ nF}$ ,  $C_O = 10 \text{ }\mu\text{F}$ , unless otherwise specified.

**Table 6. Electrical characteristics of LD29150#33**

Symbol	Parameter	Test conditions	Min.	Typ.	Max.	Unit
$V_O$	Output voltage	$I_O = 10 \text{ mA}$ to $1.5 \text{ A}$ , $V_I = 4.3$ to $8.8 \text{ V}$ $T_J = -40$ to $125 \text{ °C}$	3.267	3.3	3.333	V
			3.234		3.366	
$\Delta V_O$	Load regulation	$I_O = 10 \text{ mA}$ to $1.5 \text{ A}$		0.2	1.0	%
$\Delta V_O$	Line regulation	$V_I = 4.3$ to $13 \text{ V}$		0.06	0.5	%
SVR	Supply voltage rejection	$f = 120 \text{ Hz}$ , $V_I = 5.3 \pm 1 \text{ V}$ , $I_O = 0.75 \text{ A}$ ( <i>Note 1</i> )	52	67		dB
$V_{DROPO}$	Dropout voltage	$I_O = 250 \text{ mA}$ , $T_J = -40$ to $125 \text{ °C}$ ( <i>Note 2</i> )		0.1		V
		$I_O = 0.75 \text{ A}$ , $T_J = -40$ to $125 \text{ °C}$ ( <i>Note 2</i> )		0.2		
		$I_O = 1.5 \text{ A}$ , $T_J = -40$ to $125 \text{ °C}$ ( <i>Note 2</i> )		0.4	0.7	
$I_q$	Quiescent current	$I_O = 0.75 \text{ A}$ , $T_J = -40$ to $125 \text{ °C}$		15	40	mA
		$I_O = 1.5 \text{ A}$ , $T_J = -40$ to $125 \text{ °C}$		30	80	
		$V_I = 13 \text{ V}$ , $V_{INH} = \text{GND}$ , $T_J = -40$ to $125 \text{ °C}$		130	180	$\mu\text{A}$
$I_{sc}$	Short circuit current	$V_I - V_O = 5.5 \text{ V}$		2.2		A
$V_{IL}$	Control input logic low	OFF MODE, ( <i>Note 3</i> ), $T_J = -40$ to $125 \text{ °C}$			0.8	V
$V_{IH}$	Control input logic high	ON MODE, ( <i>Note 3</i> ), $T_J = -40$ to $125 \text{ °C}$	2			V
$I_{INH}$	Control input current	$T_J = -40$ to $125 \text{ °C}$ , $V_{INH} = 13 \text{ V}$		5	10	$\mu\text{A}$
eN	Output noise voltage	$B_P = 10 \text{ Hz}$ to $100 \text{ kHz}$ , $I_O = 100 \text{ mA}$ ( <i>Note 1</i> )		132		$\mu\text{V}_{RMS}$
$T_{SHDN}$	Thermal shutdown			150		$^{\circ}\text{C}$

Note: 1 Guaranteed by design.

2 Dropout voltage is defined as the input-to-output differential when the output voltage drops to 99 % of its nominal value with  $V_O + 1 \text{ V}$  applied to  $V_I$ .

3 Only for version with Inhibit function.

$I_O = 10 \text{ mA}$ ,  $T_J = 25 \text{ °C}$ ,  $V_I = 7 \text{ V}$ ,  $V_{INH} = 2 \text{ V}$  (*Note 3*),  $C_I = 330 \text{ nF}$ ,  $C_O = 10 \text{ }\mu\text{F}$ , unless otherwise specified.

**Table 7. Electrical characteristics of LD29150#50**

Symbol	Parameter	Test conditions	Min.	Typ.	Max.	Unit
$V_O$	Output voltage	$I_O = 10 \text{ mA to } 1.5 \text{ A}$ , $V_I = 6 \text{ to } 10.5 \text{ V}$ $T_J = -40 \text{ to } 125 \text{ °C}$	4.95	5	5.05	V
			4.9		5.1	
$\Delta V_O$	Load regulation	$I_O = 10 \text{ mA to } 1.5 \text{ A}$		0.2	1.0	%
$\Delta V_O$	Line regulation	$V_I = 6 \text{ to } 13 \text{ V}$		0.06	0.5	%
SVR	Supply voltage rejection	$f = 120 \text{ Hz}$ , $V_I = 7 \pm 1 \text{ V}$ , $I_O = 0.75 \text{ A}$ ( <i>Note 1</i> )	49	64		dB
$V_{DROPO}$	Dropout voltage	$I_O = 250 \text{ mA}$ , $T_J = -40 \text{ to } 125 \text{ °C}$ ( <i>Note 2</i> )		0.1		V
		$I_O = 0.75 \text{ A}$ , $T_J = -40 \text{ to } 125 \text{ °C}$ ( <i>Note 2</i> )		0.2		
		$I_O = 1.5 \text{ A}$ , $T_J = -40 \text{ to } 125 \text{ °C}$ ( <i>Note 2</i> )		0.4	0.7	
$I_q$	Quiescent current	$I_O = 0.75 \text{ A}$ , $T_J = -40 \text{ to } 125 \text{ °C}$		15	40	mA
		$I_O = 1.5 \text{ A}$ , $T_J = -40 \text{ to } 125 \text{ °C}$		30	80	
		$V_I = 13 \text{ V}$ , $V_{INH} = \text{GND}$ , $T_J = -40 \text{ to } 125 \text{ °C}$		130	180	$\mu\text{A}$
$I_{sc}$	Short circuit current	$V_I - V_O = 5.5 \text{ V}$		2.2		A
$V_{IL}$	Control input logic low	OFF MODE, ( <i>Note 3</i> ), $T_J = -40 \text{ to } 125 \text{ °C}$			0.8	V
$V_{IH}$	Control input logic high	ON MODE, ( <i>Note 3</i> ), $T_J = -40 \text{ to } 125 \text{ °C}$	2			V
$I_{INH}$	Control input current	$T_J = -40 \text{ to } 125 \text{ °C}$ , $V_{INH} = 13 \text{ V}$		5	10	$\mu\text{A}$
eN	Output noise voltage	$B_P = 10 \text{ Hz to } 100 \text{ kHz}$ , $I_O = 100 \text{ mA}$ ( <i>Note 1</i> )		200		$\mu\text{V}_{RMS}$
$T_{SHDN}$	Thermal shutdown			150		$^{\circ}\text{C}$

Note: 1 Guaranteed by design.

2 Dropout voltage is defined as the input-to-output differential when the output voltage drops to 99 % of its nominal value with  $V_O + 1 \text{ V}$  applied to  $V_I$ .

3 Only for version with Inhibit function.

$I_O = 10 \text{ mA}$ ,  $T_J = 25 \text{ }^\circ\text{C}$ ,  $V_I = 3.23 \text{ V}$ ,  $V_{INH} = 2 \text{ V}$  (*Note 3*),  $C_I = 330 \text{ nF}$ ,  $C_O = 10 \text{ } \mu\text{F}$  adjust pin tied to output pin.

**Table 8. Electrical characteristics of LD29150#ADJ**

Symbol	Parameter	Test conditions	Min.	Typ.	Max.	Unit
$V_I$	Minimum operating input voltage	$I_O = 10 \text{ mA}$ to $1.5 \text{ A}$ , $T_J = -40$ to $125 \text{ }^\circ\text{C}$	2.5			V
$\Delta V_O$	Load regulation	$I_O = 10 \text{ mA}$ to $1.5 \text{ A}$		0.2	1.0	%
$\Delta V_O$	Line regulation	$V_I = 2.5 \text{ V}$ to $13 \text{ V}$ , $I_O = 10 \text{ mA}$		0.06	0.5	%
$V_{REF}$	Reference voltage	$I_O = 10 \text{ mA}$ to $1.5 \text{ A}$ , $V_I = 2.5$ to $4.5 \text{ V}$ $T_J = -40$ to $125 \text{ }^\circ\text{C}$ ( <i>Note 2</i> )	-1%	1.23	+1%	V
			-2%		+2%	
SVR	Supply voltage rejection	$f = 120 \text{ Hz}$ , $V_I = 3.23 \pm 1 \text{ V}$ , $I_O = 0.75 \text{ A}$ ( <i>Note 1</i> )	45	75		dB
$I_q$	Quiescent current	$I_O = 0.75 \text{ A}$ , $T_J = -40$ to $125 \text{ }^\circ\text{C}$		15	40	mA
		$I_O = 1.5 \text{ A}$ , $T_J = -40$ to $125 \text{ }^\circ\text{C}$		30	80	
		$V_I = 13 \text{ V}$ , $V_{INH} = \text{GND}$ , $T_J = -40$ to $125 \text{ }^\circ\text{C}$		130	180	$\mu\text{A}$
$I_{ADJ}$	Adjust pin current	$T_J = -40$ to $125 \text{ }^\circ\text{C}$ ( <i>Note 1</i> )			1	$\mu\text{A}$
$I_{sc}$	Short circuit current	$V_I - V_O = 5.5 \text{ V}$		2.2		A
$V_{IL}$	Control input logic low	OFF MODE, ( <i>Note 3</i> ), $T_J = -40$ to $125 \text{ }^\circ\text{C}$			0.8	V
$V_{IH}$	Control input logic high	ON MODE, ( <i>Note 3</i> ), $T_J = -40$ to $125 \text{ }^\circ\text{C}$	2			V
$I_{INH}$	Control input current	$T_J = -40$ to $125 \text{ }^\circ\text{C}$ , $V_{INH} = 13 \text{ V}$		5	10	$\mu\text{A}$
eN	Output noise voltage	$B_P = 10 \text{ Hz}$ to $100 \text{ kHz}$ , $I_O = 100 \text{ mA}$ ( <i>Note 1</i> )		50		$\mu\text{V}_{RMS}$
$T_{SHDN}$	Thermal shutdown			150		$^\circ\text{C}$

Note: 1 Guaranteed by design.

2 Reference voltage is measured between output and GND pin, with ADJ PIN tied to  $V_{OUT}$ .

3 Only for version with Inhibit function.

# 6 Typical characteristics

Figure 5. Output voltage vs. temperature

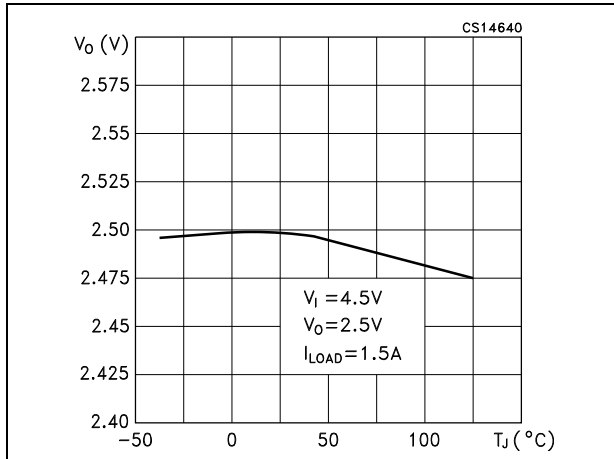

Figure 6. Reference voltage vs. temperature

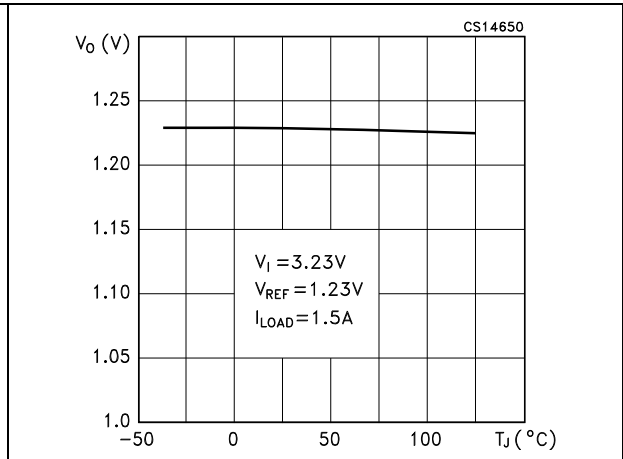

Figure 7. Dropout voltage vs. temperature

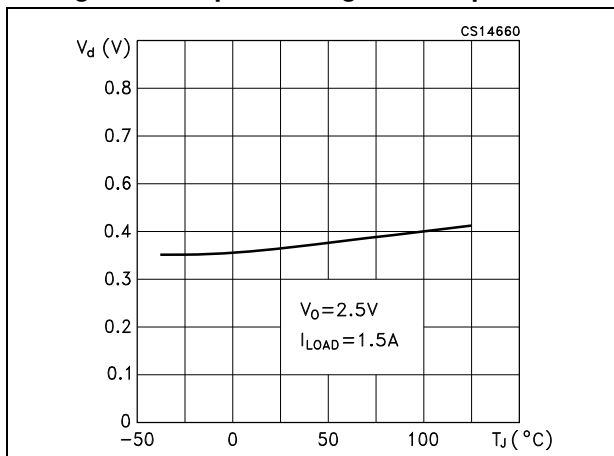

Figure 8. Dropout voltage vs. output current

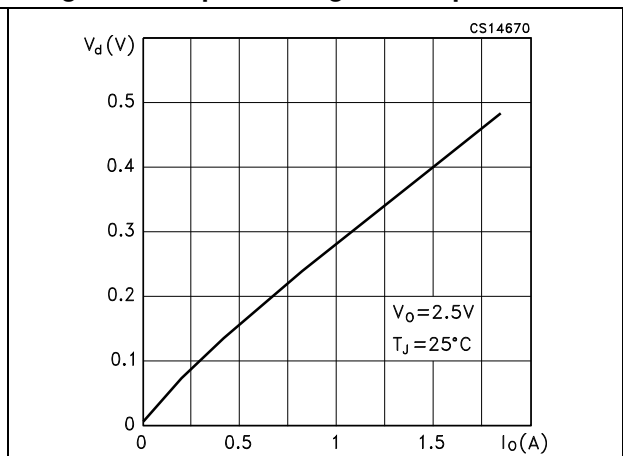

Figure 9. Quiescent current vs. output current (V<sub>i</sub> = 13 V)

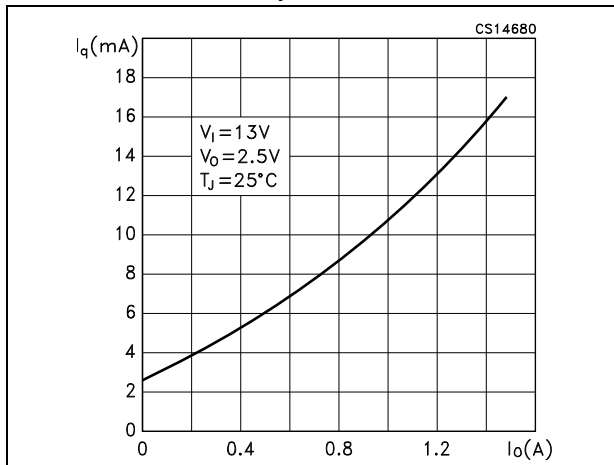

Figure 10. Quiescent current vs. output current (V<sub>i</sub> = 4.5 V)

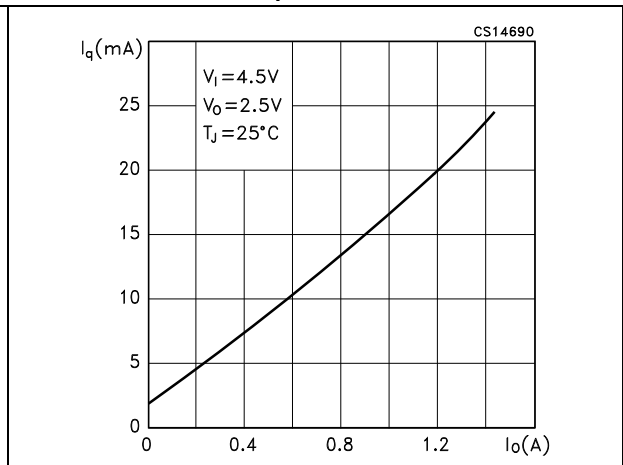

Figure 11. Quiescent current vs. supply voltage      Figure 12. Quiescent current vs. temperature ( $I_O = 10\text{ mA}$ )

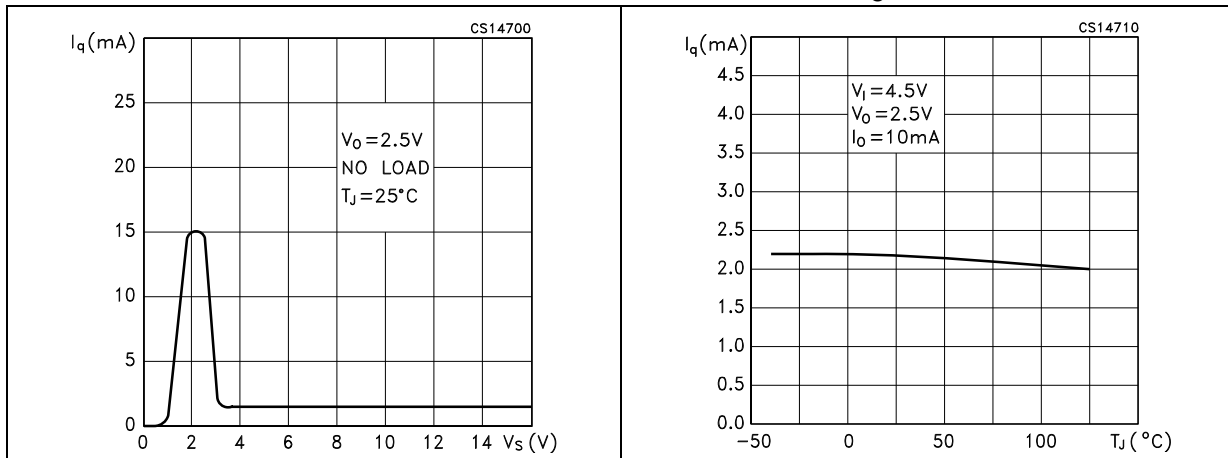

Figure 13. Quiescent current vs. temperature ( $I_O = 1.5\text{ A}$ )      Figure 14. Short circuit current vs. temperature

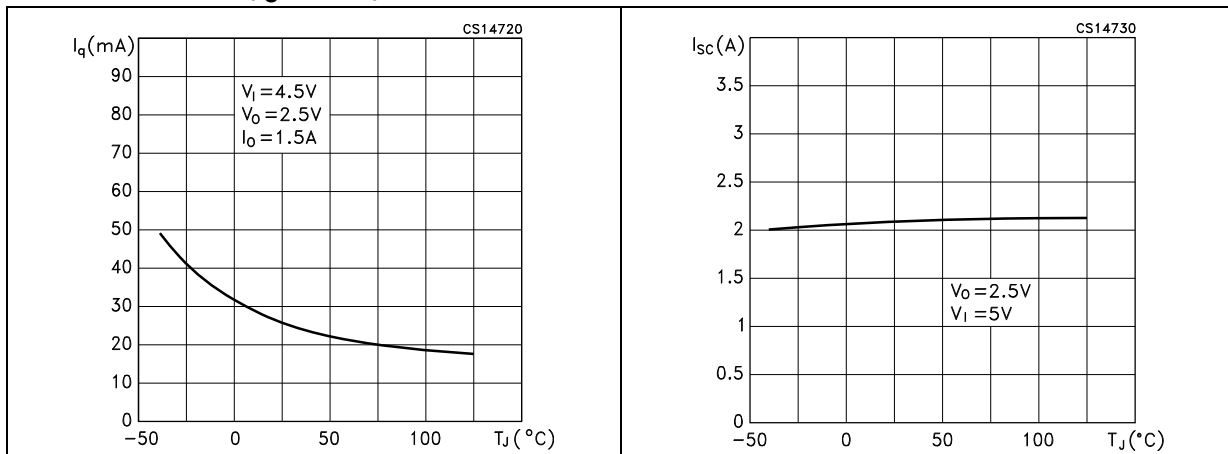

Figure 15. Adjust pin current vs. temperature      Figure 16. Supply voltage rejection vs. temperature

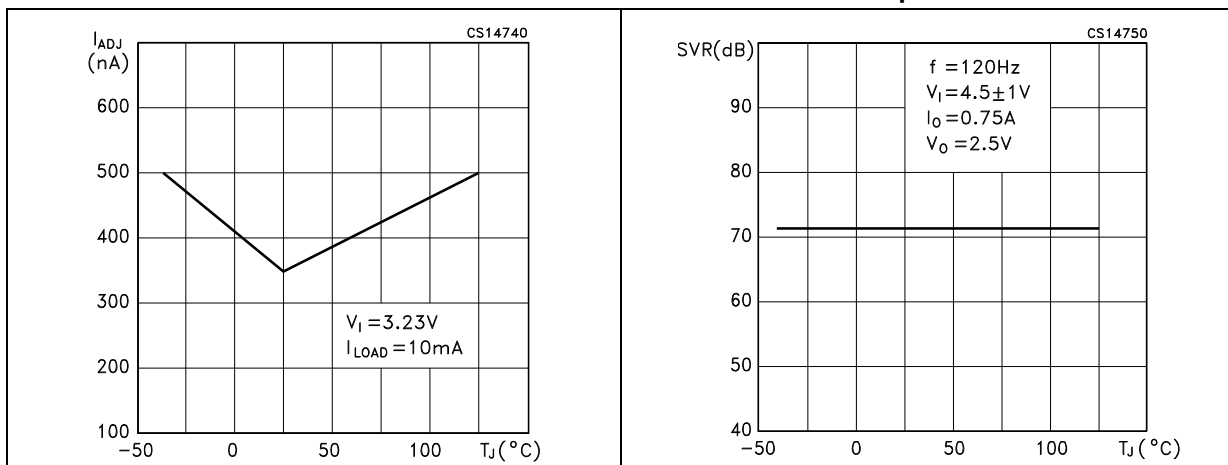

Figure 17. Output voltage vs. input voltage

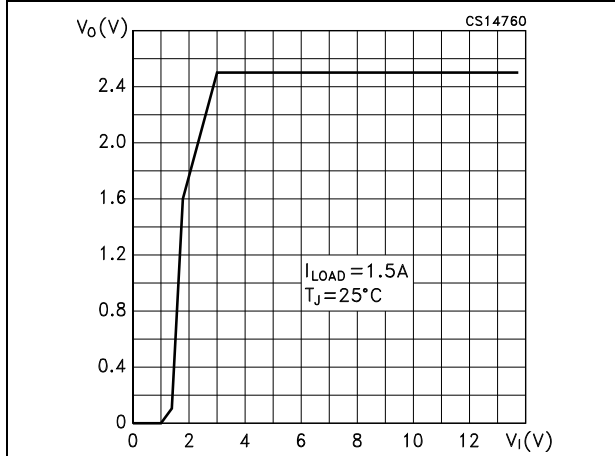

Figure 18. Stability vs.  $C_O$

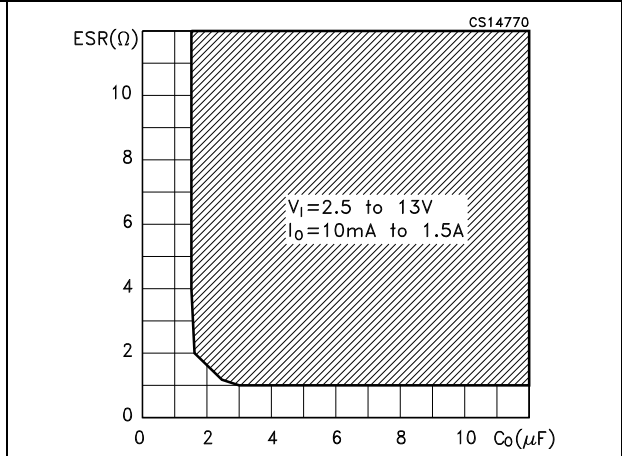

Figure 19. Line transient

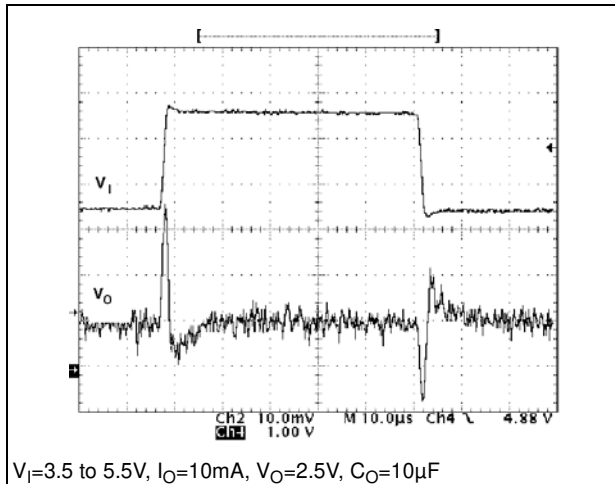

Figure 20. Load transient

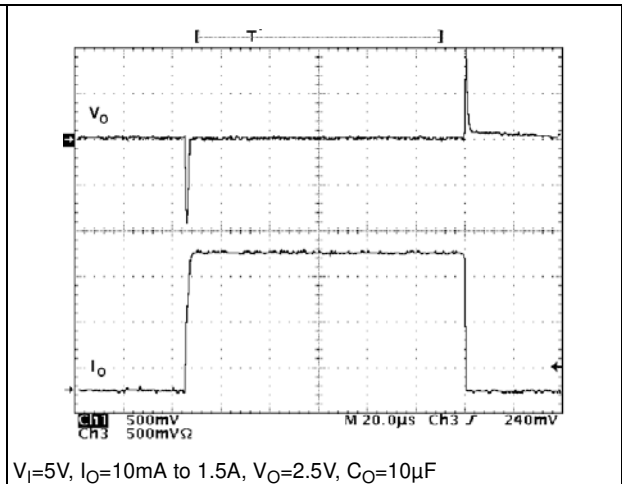

Figure 21. Start-up time 10 mA

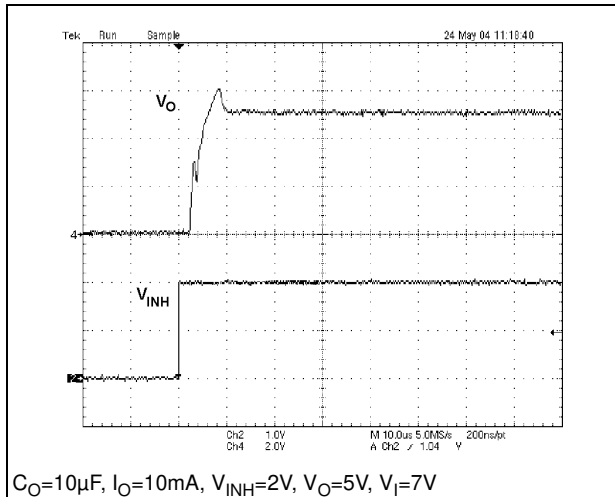
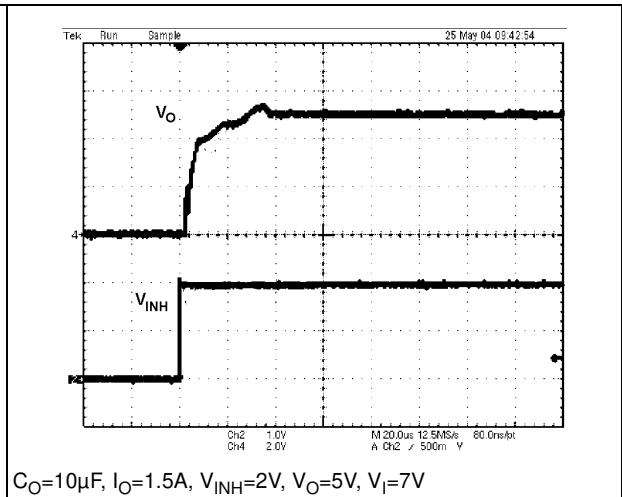

Figure 22. Start-up time 1.5 A



## 7 Package mechanical data

In order to meet environmental requirements, ST offers these devices in different grades of ECOPACK<sup>®</sup> packages, depending on their level of environmental compliance. ECOPACK<sup>®</sup> specifications, grade definitions and product status are available at: [www.st.com](http://www.st.com). ECOPACK<sup>®</sup> is an ST trademark.

**Table 9. DPAK mechanical data**

Dim.	mm		
	Min.	Typ.	Max.
A	2.20		2.40
A1	0.90		1.10
A2	0.03		0.23
b	0.64		0.90
b4	5.20		5.40
c	0.45		0.60
c2	0.48		0.60
D	6.00		6.20
D1		5.10	
E	6.40		6.60
E1		4.70	
e		2.28	
e1	4.40		4.60
H	9.35		10.10
L	1.00		1.50
(L1)		2.80	
L2		0.80	
L4	0.60		1.00
R		0.20	
V2	0°		8°



Figure 23. DPAK drawing

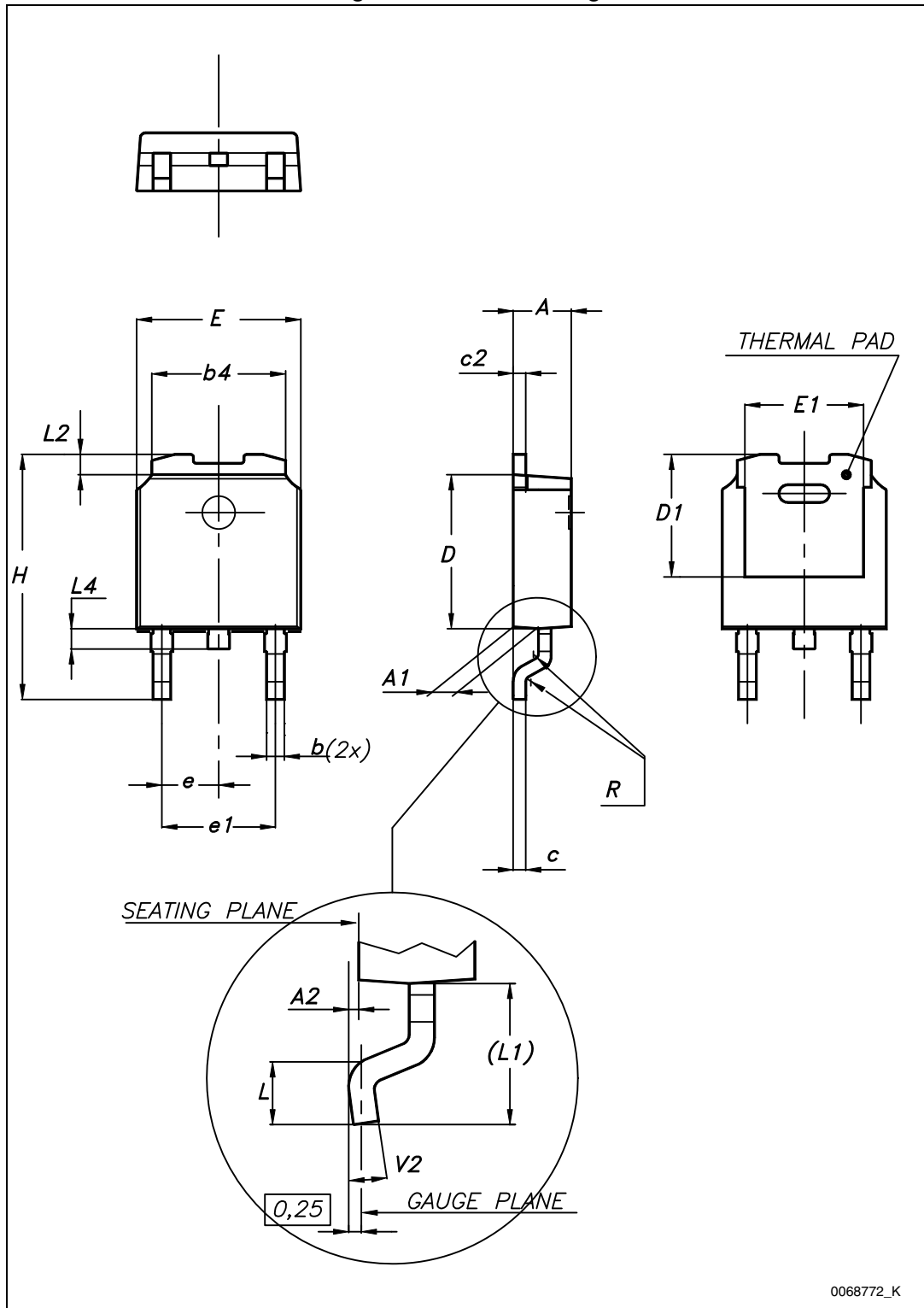
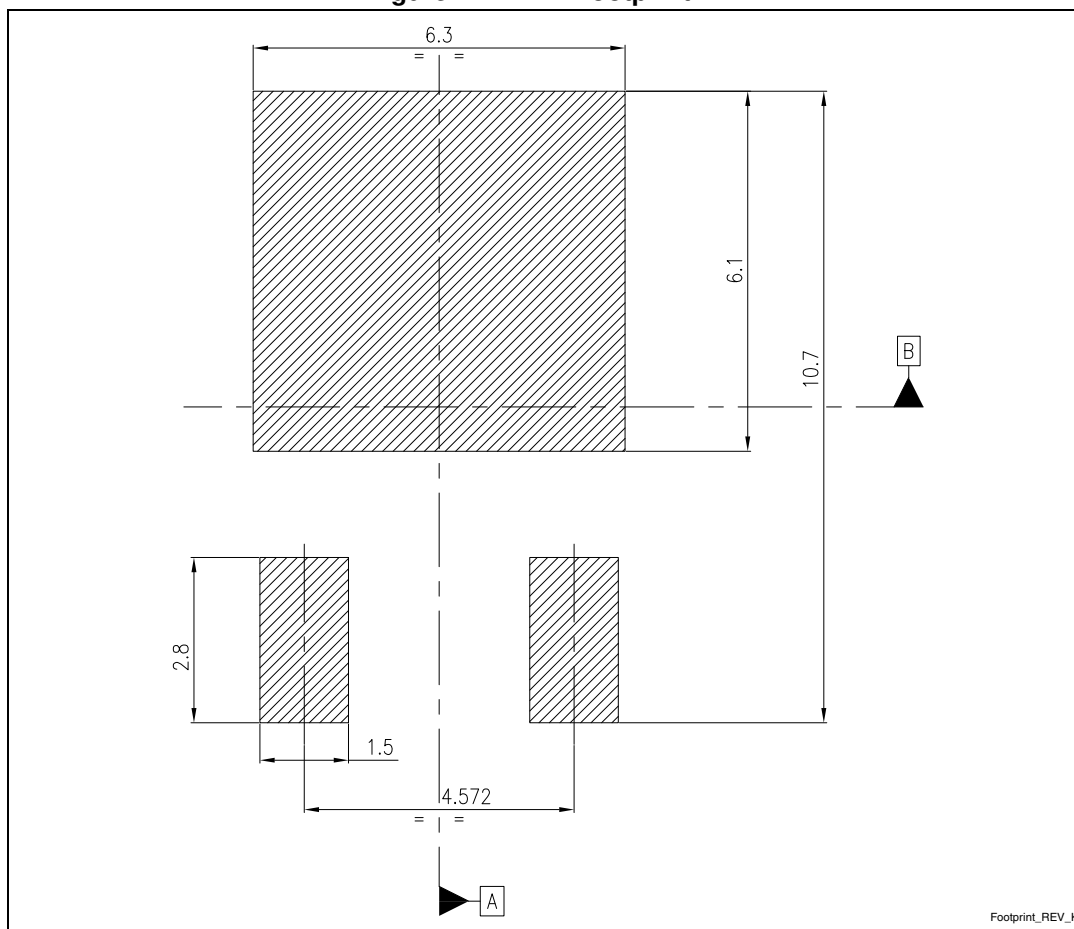

Figure 24. DPAK footprint (a)



a. All dimensions are in millimeters

Table 10. PPAK mechanical data

Dim.	mm		
	Min.	Typ.	Max.
A	2.2		2.4
A1	0.9		1.1
A2	0.03		0.23
B	0.4		0.6
B2	5.2		5.4
C	0.45		0.6
C2	0.48		0.6
D	6		6.2
D1		5.1	
E	6.4		6.6
E1		4.7	
e		1.27	
G	4.9		5.25
G1	2.38		2.7
H	9.35		10.1
L2		0.8	1
L4	0.6		1
L5	1		
L6		2.8	
R		0.20	
V2	0°		8°

Figure 25. PPAK drawings

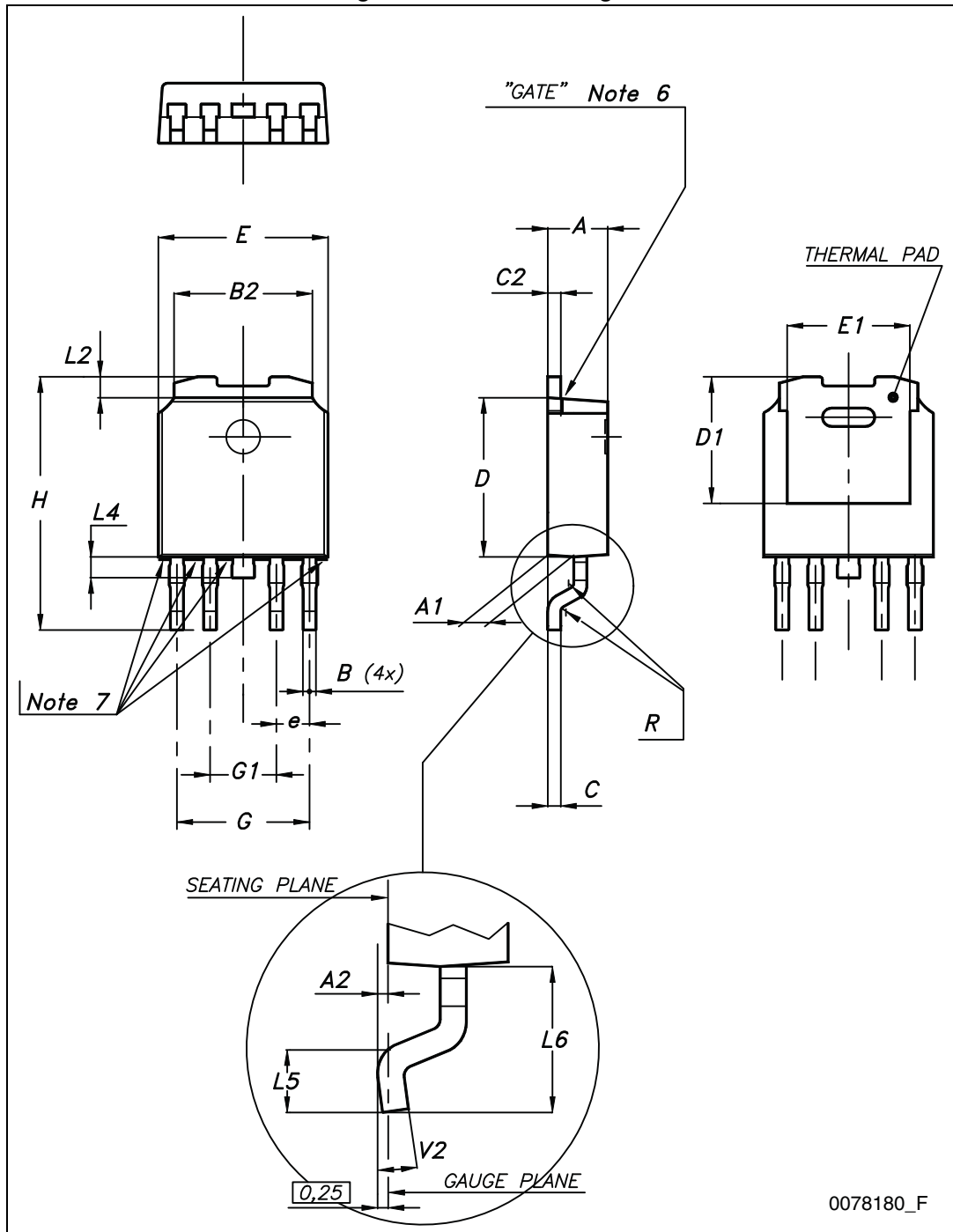

0078180\_F

Table 11. P<sup>2</sup>PAK mechanical data

Dim.	mm		
	Min.	Typ.	Max.
A	4.30		4.80
A1	2.40		2.80
A2	0.03		0.23
b	0.80		1.05
c	0.45		0.60
c2	1.17		1.37
D	8.95		9.35
D2		8	
E	10		10.40
E1		8.5	
e	3.20		3.60
e1	6.60		7
L	13.70		14.50
L2	1.25		1.40
L3	0.90		1.70
L5	1.55		2.40
R		0.40	
V2	0°		8°

Figure 26. P<sup>2</sup>PAK drawings

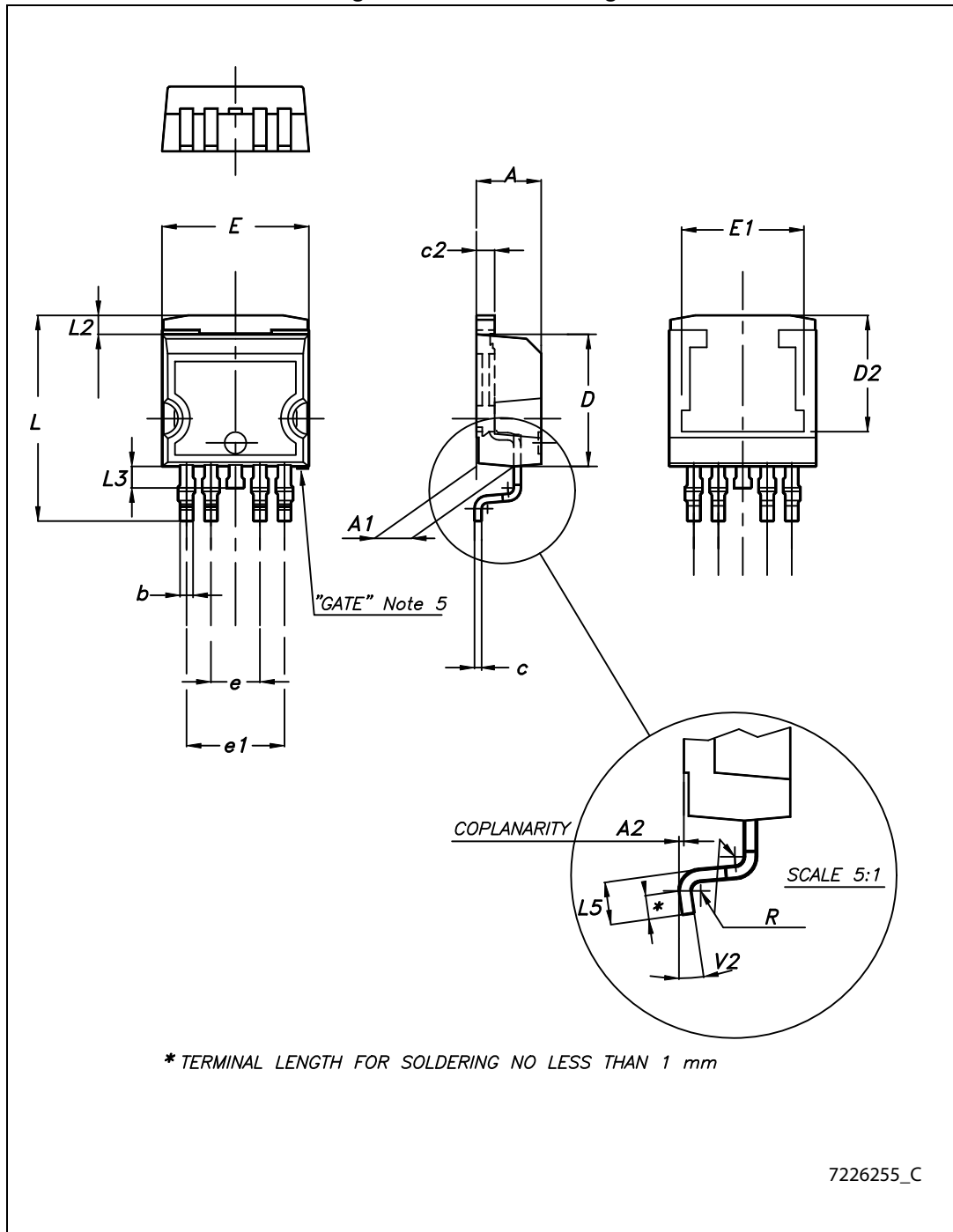
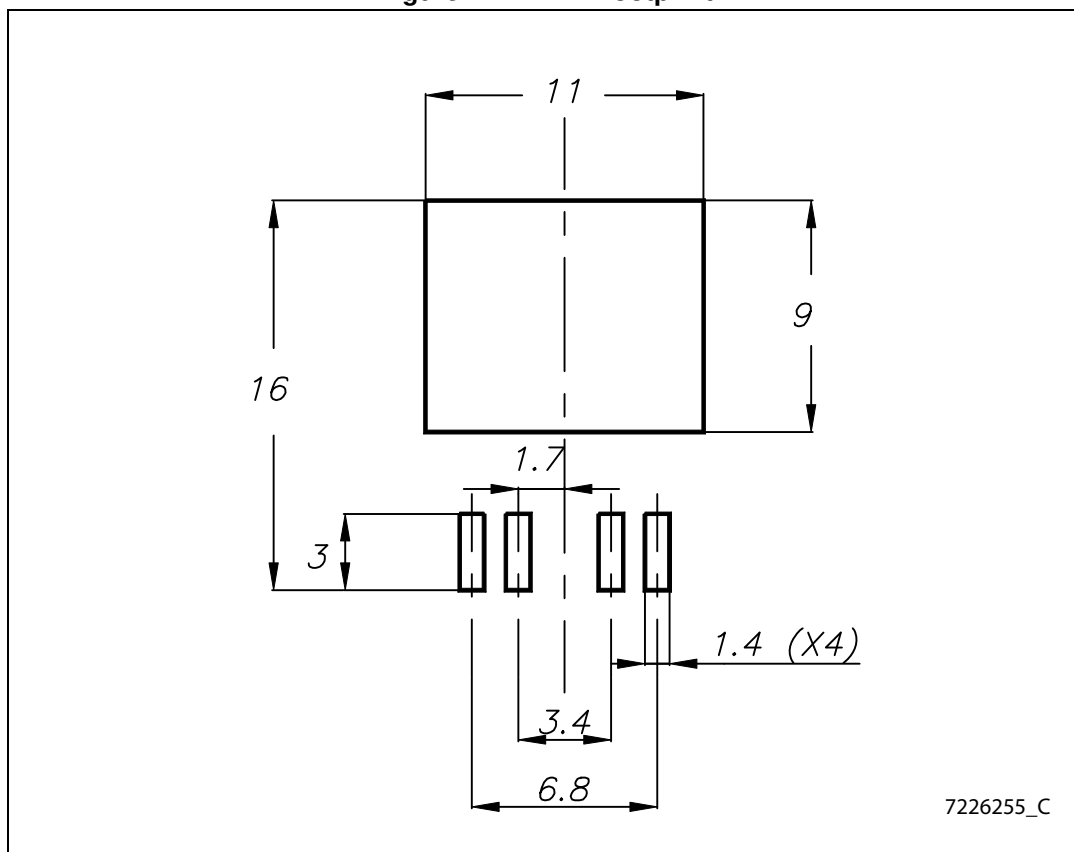

Figure 27. P<sup>2</sup>PAK footprint



7226255\_C

## 8 Packaging mechanical data

Table 12. PPAK and DPAK tape and reel mechanical data

Tape			Reel		
Dim.	mm		Dim.	mm	
	Min.	Max.		Min.	Max.
A0	6.8	7	A		330
B0	10.4	10.6	B	1.5	
B1		12.1	C	12.8	13.2
D	1.5	1.6	D	20.2	
D1	1.5		G	16.4	18.4
E	1.65	1.85	N	50	
F	7.4	7.6	T		22.4
K0	2.55	2.75			
P0	3.9	4.1	Base qty.		2500
P1	7.9	8.1	Bulk qty.		2500
P2	1.9	2.1			
R	40				
T	0.25	0.35			
W	15.7	16.3			



Figure 28. Tape for PPAK and DPAK

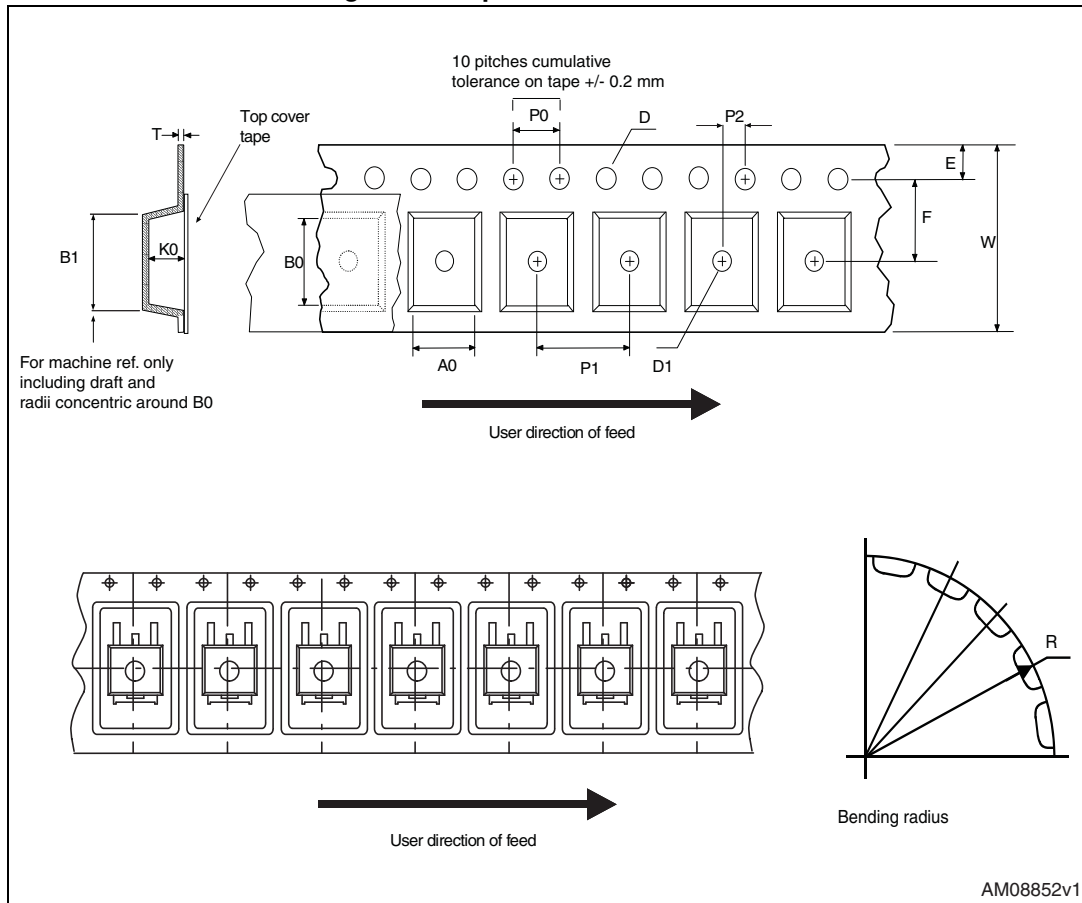

Figure 29. Reel for PPAK and DPAK

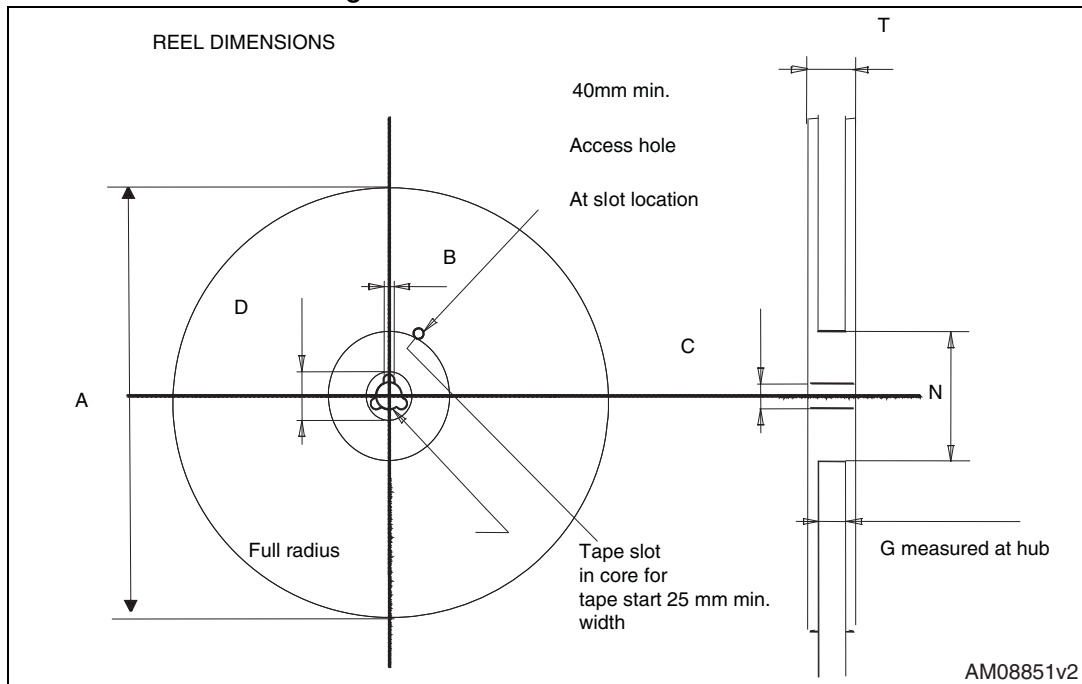

Table 13. P<sup>2</sup>PAK tape and reel mechanical data

Dim.	mm		
	Min.	Typ.	Max.
A			180
C	12.8	13	13.2
D	20.2		
N	60		
T			14.4
Ao	10.50	10.6	10.70
Bo	15.70	15.80	15.90
Ko	4.80	4.90	5.00
Po	3.9	4.0	4.1
P	11.9	12.0	12.1

Figure 30. P<sup>2</sup>PAK tape and reel dimensions

