



Chipsmall Limited consists of a professional team with an average of over 10 year of expertise in the distribution of electronic components. Based in Hongkong, we have already established firm and mutual-benefit business relationships with customers from,Europe,America and south Asia,supplying obsolete and hard-to-find components to meet their specific needs.

With the principle of “Quality Parts,Customers Priority,Honest Operation,and Considerate Service”,our business mainly focus on the distribution of electronic components. Line cards we deal with include Microchip,ALPS,ROHM,Xilinx,Pulse,ON,Everlight and Freescale. Main products comprise IC,Modules,Potentiometer,IC Socket,Relay,Connector.Our parts cover such applications as commercial,industrial, and automotives areas.

We are looking forward to setting up business relationship with you and hope to provide you with the best service and solution. Let us make a better world for our industry!



Contact us

Tel: +86-755-8981 8866 Fax: +86-755-8427 6832

Email & Skype: info@chipsmall.com Web: www.chipsmall.com

Address: A1208, Overseas Decoration Building, #122 Zhenhua RD., Futian, Shenzhen, China



1.2 A low quiescent current LDO with reverse current protection

Datasheet - production data

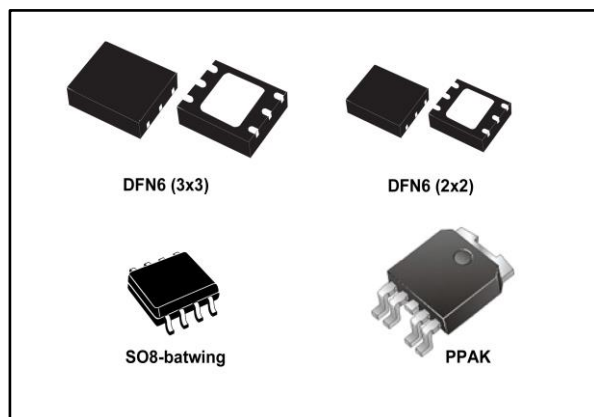

Features

- Input voltage from 1.6 to 5.5 V
- Very low-dropout voltage (300 mV typ. at 1 A load)
- Low quiescent current (35 μ A typ. at no-load, 1 μ A max. in off mode)
- Output voltage tolerance: $\pm 2.0\%$ at 25 °C
- 1.2 A guaranteed output current
- Wide range of output voltages available on request: 0.8 V to 5 V with 50 mV step and adjustable
- Logic-controlled electronic shutdown
- Compatible with ceramic capacitor
 $C_{OUT} = 1 \mu$ F
- Internal current and thermal limit
- Available in DFN6 (2x2), DFN6 (3x3) mm, SO8-batwing and PPAK packages
- Temperature range: -40 °C to 125 °C
- Reverse current protection
- Output discharge function (optional)

Applications

- Consumer
- Computer
- Battery-powered systems
- Low voltage point-of-load
- USB-powered devices

Description

The LDL112 is a low-dropout linear regulator, which can provide a maximum current of 1.2 A, with a typical dropout voltage of 300 mV.

It is stabilized with a ceramic capacitor on the output.

The very low drop voltage, low quiescent current and reverse current protection features make it suitable for low power battery-powered applications.

The enable logic control function puts the LDL112 in shutdown mode allowing a total current consumption lower than 1 μ A.

The device is equipped with current limit and thermal protection.

Contents

1	Diagram	3
2	Pin configuration	4
3	Typical application	5
4	Maximum ratings	6
5	Electrical characteristics	7
6	Application information	9
	6.1 Thermal and short-circuit protections	9
	6.2 Output voltage setting for ADJ version.....	9
	6.3 Reverse current protection.....	10
7	Typical performance characteristics	11
8	Package information	15
	8.1 DFN6 (3x3) package information	15
	8.2 DFN6 (3x3) packing information.....	17
	8.3 DFN6 (2x2) package information	19
	8.4 DFN6 (2x2) packing information.....	22
	8.5 SO8-batwing package information	23
	8.6 SO8-batwing packing information	25
	8.7 PPAK package information	26
	8.8 PPAK packing information	28
9	Ordering information	30
10	Revision history	31

1 Diagram

Figure 1: Block diagram

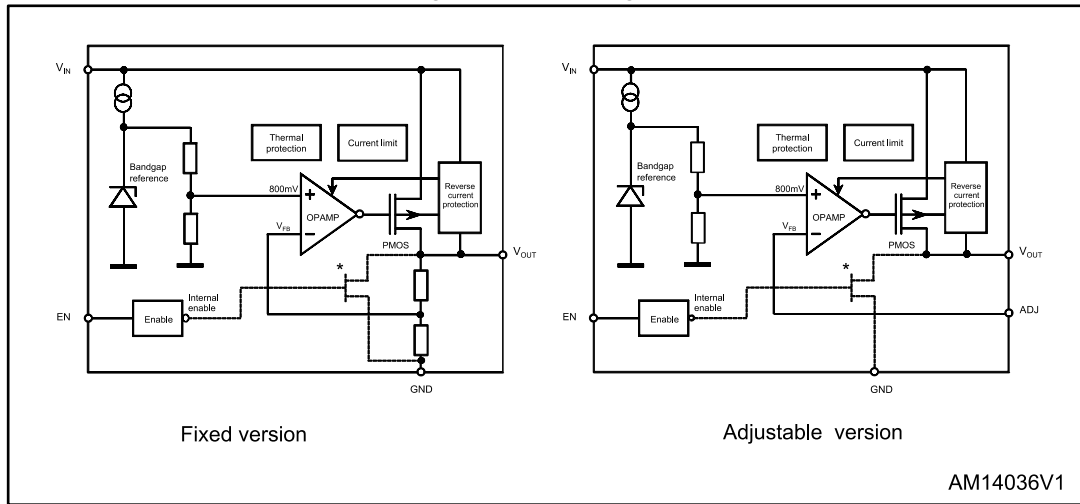

(*) The output discharge function is optional.

2 Pin configuration

Figure 2: Pin connection DFN6 (3x3) and DFN6 (2x2) (top view)

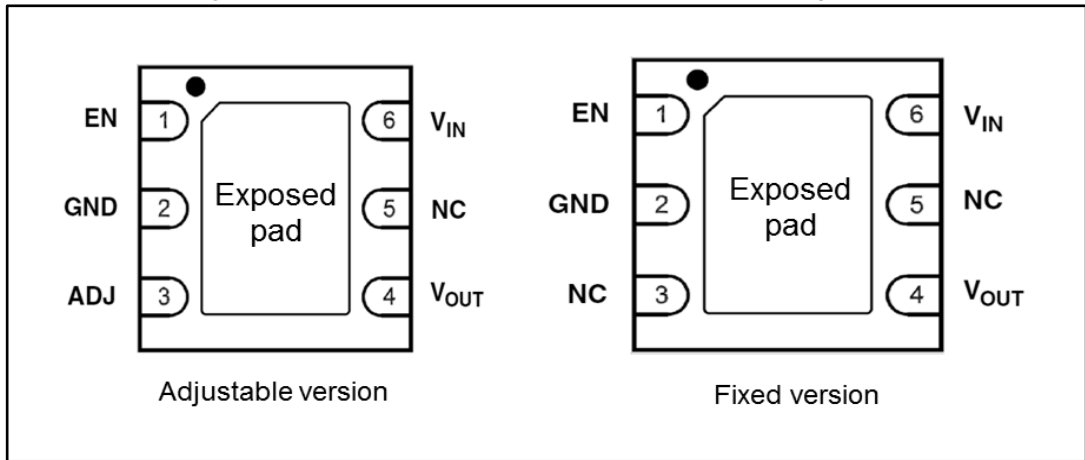
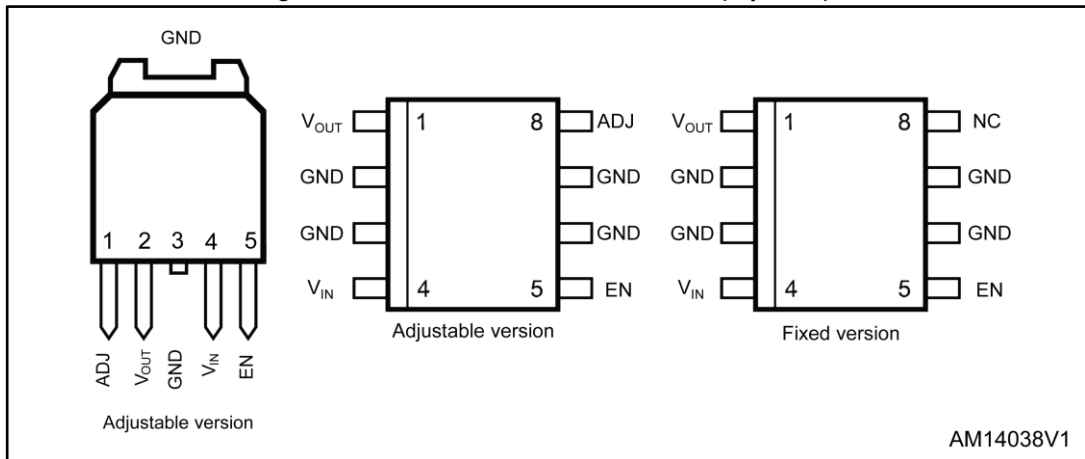

Figure 3: Pin connection PPAK and SO8 (top view)



AM14038V1

Table 1: Pin description

Symbol	Function
V _{IN}	LDO input voltage
GND	Common ground
EN	Enable pin logic input: low = shutdown, high = active
ADJ	Adjustable pin (on adjustable version)
V _{OUT}	LDO output voltage
Exposed pad	Must be connected to GND
NC	Not connected

3 Typical application

Figure 4: Typical application circuits

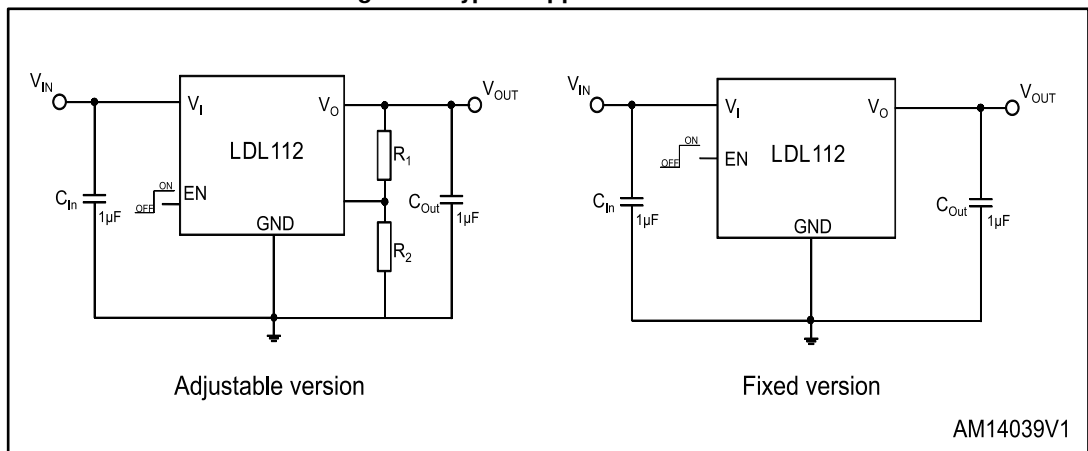

4 Maximum ratings

Table 2: Absolute maximum ratings

Symbol	Parameter	Value	Unit
V _{IN}	DC input voltage	- 0.3 to 7	V
V _{OUT}	DC output voltage	- 0.3 to V _I + 0.3	V
V _{EN}	Enable input voltage	- 0.3 to V _I + 0.3	V
V _{ADJ}	ADJ pin voltage	2	V
I _{OUT}	Output current	Internally limited	mA
P _D	Power dissipation	Internally limited	mW
T _{STG}	Storage temperature range	- 65 to 150	°C
T _{OP}	Operating junction temperature range	- 40 to 125	°C



Absolute maximum ratings are those values beyond which damage to the device may occur. Functional operation under these conditions is not implied. All values are referred to GND.

Table 3: Thermal data

Symbol	Parameter	DFN6 (3x3)	DFN6 (2x2)	SO8	PPAK	Unit
R _{thJA}	Thermal resistance junction-ambient	55	65	55 ⁽¹⁾	100	°C/W
R _{thJC}	Thermal resistance junction-case	10	15	20	8	°C/W

Notes:

⁽¹⁾Considering 6 cm² of copper board heatsink.

5 Electrical characteristics

$T_J = 25\text{ }^\circ\text{C}$, $V_{IN} = V_{OUT(NOM)} + 0.5\text{ V}$ (for $V_{OUT(NOM)} \leq 1\text{ V}$, $V_{IN} = 2.1\text{ V}$), $C_{IN} = C_{OUT} = 1\text{ }\mu\text{F}$,
 $I_{OUT} = 5\text{ mA}$, $V_{EN} = V_{IN}$, unless otherwise specified.

Table 4: LDL112 electrical characteristics (fixed version)

Symbol	Parameter	Test conditions	Min.	Typ.	Max.	Unit
V_{IN}	Operating input voltage		1.6		5.5	V
V_{OUT}	V_{OUT} accuracy	$I_{OUT} = 5\text{ mA}$, $T_J = 25\text{ }^\circ\text{C}$	-2.0		2.0	%
		$I_{OUT} = 5\text{ mA}$, $-40\text{ }^\circ\text{C} < T_J < 125\text{ }^\circ\text{C}$	-3.0		3.0	%
ΔV_{OUT}	Static line regulation ⁽¹⁾	$V_{OUT(NOM)} + 0.5\text{ V} < V_{IN} \leq 5.5\text{ V}$ ⁽²⁾		0.05	0.1	%/V
ΔV_{OUT}	Static load regulation	$I_{OUT} = 0\text{ mA}$ to 1.2 A , $V_{IN} > 2.1\text{ V}$		15	30	mV
V_{DROP}	Dropout voltage ⁽³⁾	$I_{OUT} = 1\text{ A}$, $V_{OUT} = 3.3\text{ V}$		300		mV
		$I_{OUT} = 1.2\text{ A}$, $V_{OUT} = 3.3\text{ V}$ $40\text{ }^\circ\text{C} < T_J < 125\text{ }^\circ\text{C}$		350	600	
e_N	Output noise voltage	10 Hz to 100 kHz, $I_{OUT} = 10\text{ mA}$		135		μV_{RMS}
SVR	Supply voltage rejection	$V_{IN} = V_{OUT(NOM)} + 0.5\text{ V}$ ⁽²⁾ +/- V_{RIPPLE} $V_{RIPPLE} = 0.2\text{ V}$ frequency = 1 kHz, $I_{OUT} = 10\text{ mA}$		57		dB
I_Q	Quiescent current	$I_{OUT} = 0\text{ mA}$, $-40\text{ }^\circ\text{C} < T_J < 125\text{ }^\circ\text{C}$		35	70	μA
		$I_{OUT} = 1.2\text{ A}$, $V_{OUT(NOM)} + 1\text{ V}$ ⁽²⁾ $40\text{ }^\circ\text{C} < T_J < 125\text{ }^\circ\text{C}$		250	400	
		V_{IN} input current in off mode: $V_{EN} = \text{GND}$		0.1	1	
I_{SC}	Short-circuit current	$R_L = 0$, $V_{IN} > 2.1\text{ V}$	1.4	2		A
V_{EN}	Enable input logic low	$V_{IN} = V_{OUT(NOM)} + 0.5\text{ V}$ ⁽²⁾ to 5.5 V , $-40\text{ }^\circ\text{C} < T_J < 125\text{ }^\circ\text{C}$			0.35	V
	Enable input logic high	$V_{IN} = V_{OUT(NOM)} + 0.5\text{ V}$ ⁽²⁾ to 5.5 V $-40\text{ }^\circ\text{C} < T_J < 125\text{ }^\circ\text{C}$	1.4			
I_{EN}	Enable pin input current	$V_{EN} = V_{IN}$			100	nA
T_{SHDN}	Thermal shutdown			165		$^\circ\text{C}$
	Hysteresis			20		
C_{OUT}	Output capacitor	Capacitance (see Section 7: "Typical performance characteristics")	1		10	μF

Notes:

⁽¹⁾Not applicable for $V_{out(nom)} > 4.5\text{ V}$.

⁽²⁾For V_{OUTNOM} lower than or equal to 1 V , $V_{IN} = 2.1\text{ V}$.

⁽³⁾Dropout voltage is the input-to-output voltage difference at which the output voltage is 100 mV below its nominal value.

$T_J = 25\text{ °C}$, $V_{IN} = 2.1\text{ V}$, $C_{IN} = C_{OUT} = 1\text{ }\mu\text{F}$, $I_{OUT} = 5\text{ mA}$, $V_{EN} = V_{IN}$, unless otherwise specified.

Table 5: LDL112 electrical characteristics (adjustable version)

Symbol	Parameter	Test conditions	Min.	Typ.	Max.	Unit
V_{IN}	Operating input voltage		1.6		5.5	V
V_{ADJ}	V_{ADJ} accuracy	$I_{OUT} = 5\text{ mA}$, $T_J = 25\text{ °C}$	784	800	816	mV
		$I_{OUT} = 5\text{ mA}$, $-40\text{ °C} < T_J < 125\text{ °C}$	-3.0		3.0	%
ΔV_{OUT}	Static line regulation ⁽¹⁾	$2.1\text{ V}^{(2)} \leq V_{IN} \leq 5.5\text{ V}$, $I_{OUT} = 1\text{ mA}$		0.05	0.1	%/V
ΔV_{OUT}	Static load regulation	$I_{OUT} = 0\text{ mA}$ to 1.2 A , $V_{IN} > 2.1\text{ V}$		6	20	mV
V_{DROP}	Dropout voltage ⁽³⁾	$I_{OUT} = 1\text{ A}$, $V_{OUT} = 3.3\text{ V}$		300		mV
		$I_{OUT} = 1.2\text{ A}$, $V_{OUT} = 3.3\text{ V}$ $40\text{ °C} < T_J < 125\text{ °C}$		350	600	
e_N	Output noise voltage	10 Hz to 100 kHz, $I_{OUT} = 10\text{ mA}$		60		μV_{RMS}
I_{ADJ}	Adjust pin current			0.130	1	μA
SVR	Supply voltage rejection	$V_{IN} = V_{OUTNOM} + 0.5\text{ V}^{(2)}$ +/- V_{RIPPLE} $V_{RIPPLE} = 0.2\text{ V}$ frequency = 1 kHz $I_{OUT} = 10\text{ mA}$		53		dB
I_Q	Quiescent current	$I_{OUT} = 0\text{ mA}$, $-40\text{ °C} < T_J < 125\text{ °C}$		35	70	μA
		$I_{OUT} = 1.2\text{ A}$, $2.1\text{ V} < V_{IN} < 5.5\text{ V}$, $-40\text{ °C} < T_J < 125\text{ °C}$		240	400	
		V_{IN} input current in off mode: $V_{EN} = \text{GND}$		0.1	1	
I_{SC}	Short-circuit current	$R_L = 0$, $V_{IN} > 2.1\text{ V}$	1.4	2		A
V_{EN}	Enable input logic low	$V_{IN} = 2\text{ V}^{(2)}$ to 5.5 V , $-40\text{ °C} < T_J < 125\text{ °C}$		0	0.35	V
	Enable input logic high	$V_{IN} = 2\text{ V}^{(2)}$ to 5.5 V , $-40\text{ °C} < T_J < 125\text{ °C}$	1.4			
I_{EN}	Enable pin input current	$V_{EN} = V_{IN}$			100	nA
T_{SHDN}	Thermal shutdown			165		$^{\circ}\text{C}$
	Hysteresis			20		
C_{OUT}	Output capacitor	Capacitance (see Section 7: "Typical performance characteristics")	1		10	μF

Notes:

⁽¹⁾Not applicable for $V_{out(nom)} > 4.5\text{ V}$.

⁽²⁾For V_{OUT} lower than or equal to 1 V, $V_{IN} = 2.1\text{ V}$.

⁽³⁾Dropout voltage is the input-to-output voltage difference at which the output voltage is 100 mV below its nominal value.

6 Application information

6.1 Thermal and short-circuit protections

The LDL112 is self-protected from short-circuit condition and overtemperature. When the output load is higher than the one supported by the device, the output current increases until the limit of typically 2 A is reached, at this point the current is kept constant even when the load impedance is zero.

Thermal protection acts when the junction temperature reaches 165 °C, therefore the IC shuts down. As soon as the junction temperature falls again below the thermal hysteresis value the device starts working again.

In order to calculate the maximum power that the device can dissipate, keeping the junction temperature below the T_{OP} , the following formula is used:

Equation 1

$$P_{DMAX} = (125 - T_{AMB}) / R_{THJA}$$

6.2 Output voltage setting for ADJ version

In the adjustable version, the output voltage can be set from 0.8 V up to the input voltage minus the voltage drop across the pass transistor (dropout voltage), by connecting a resistor divider between the ADJ pin and the output, thus allowing remote voltage sensing.

The resistor divider could be selected by the following equation:

Equation 2

$$V_{OUT} = V_{ADJ} (1 + R1 / R2), \text{ with } V_{ADJ} = 0.8 \text{ V (typ.)}$$

It is recommended to use resistors with values in the range of 10 kΩ to 50 kΩ. Lower values can also be suitable, but current consumption increases.

6.3 Reverse current protection

The device avoids the reverse current to flow from output to input during any operating condition (with enable pin in high or low status). The reverse current protection acts in particular during fast turning on/off operations or when another power supply (with higher voltage than the input one) is connected to the output port. If a power supply with lower voltage than the LDO output voltage is connected to V_{OUT} pin, LDO enters the current protection status, causing high power dissipation.

In the application, the LDL112 reverse current protection acts in the following cases:

1. **Off-state, EN pin is at GND level, $V_{OUT} > [V_{IN} + 100 \text{ mV}]$.** In this case the device power pass element (MOSFET) is off, the bulk and gate are switched to V_{OUT} and therefore all possible current paths from V_{OUT} to V_{IN} are interrupted.
2. **On-state, EN pin is at high level and $V_{OUT} > V_{OUT(nominal)}$.** In this condition, V_{OUT} is higher than the nominal level, so the device op-amp works in open loop and the power element is off. V_{GS} is zero, the bulk and gate are switched to V_{OUT} (where $V_{OUT} > [V_{IN} + 100 \text{ mV}]$) therefore all possible current paths from V_{OUT} to V_{IN} are interrupted.
3. **On-state, EN pin is at high level and $V_{OUT} < V_{OUT(nominal)}$.** In this condition V_{OUT} is lower than the nominal level, so the op-amp works in open loop with the power MOSFET on. V_{GS} is maximal so the power channel conducts with very low $R_{DS(on)}$. When $V_{OUT} > V_{IN}$ the current can flow from V_{OUT} to V_{IN} until the condition $V_{OUT} > (V_{IN} + 100 \text{ mV})$ is reached.

7 Typical performance characteristics

($C_{IN} = C_{OUT} = 1 \mu F$, V_{EN} to V_{IN} , $T = 25^\circ C$ unless otherwise specified)

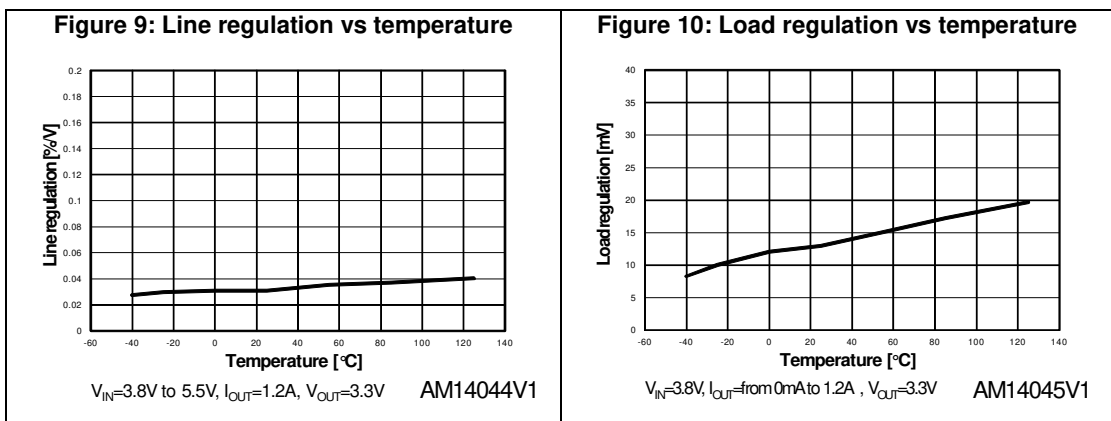
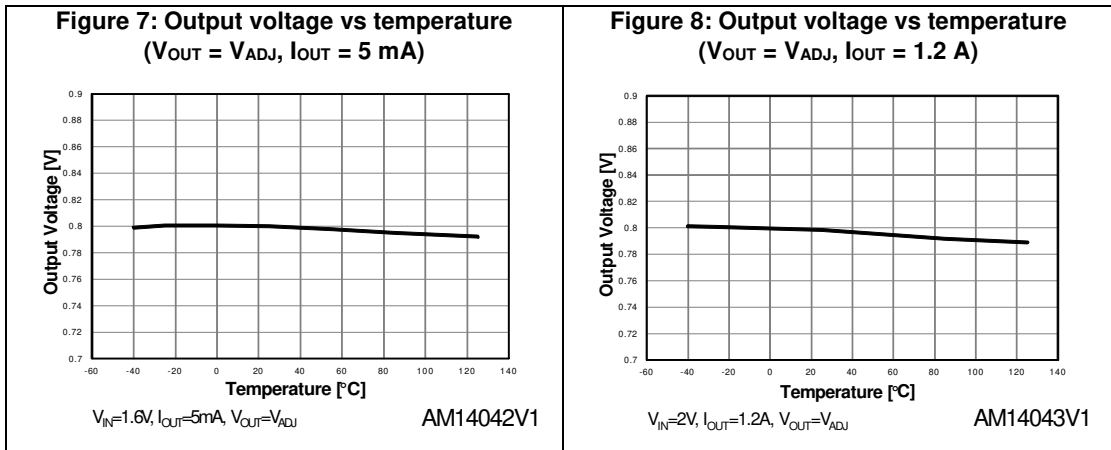
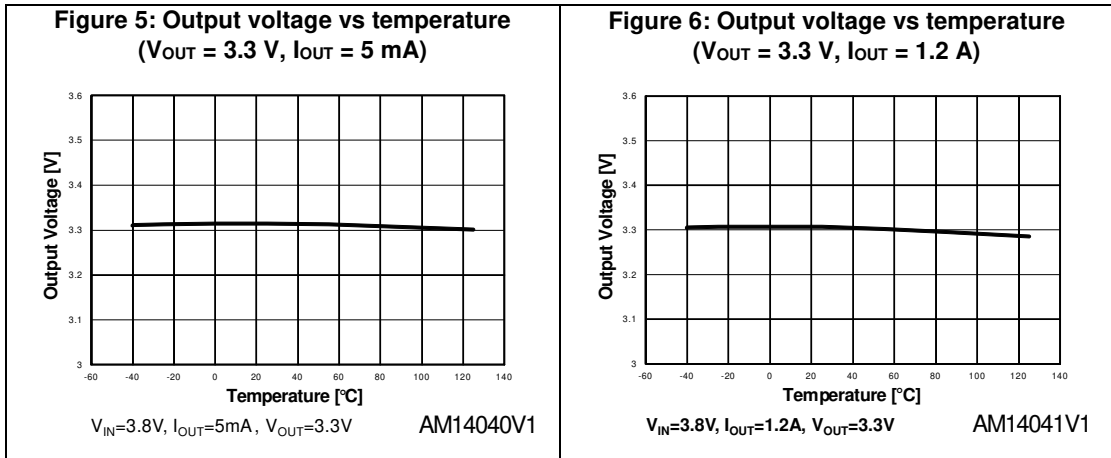
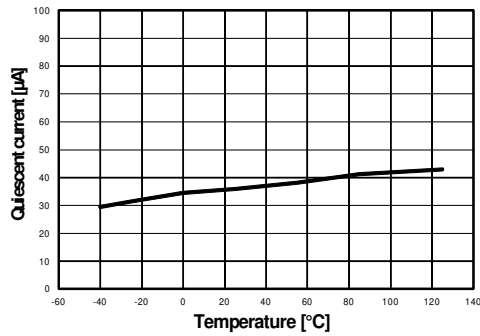
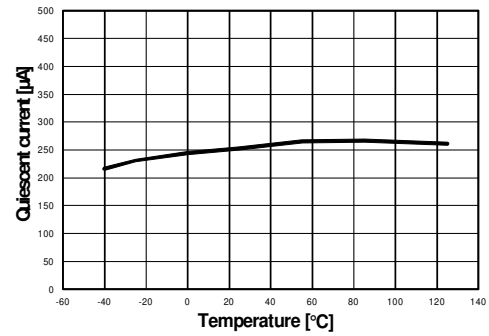

Figure 11: Quiescent current vs temperature
($I_{OUT} = 0 \text{ mA}$)



$V_{IN}=3.8\text{V}$, $I_{OUT}=0\text{mA}$, $V_{OUT}=3.3\text{V}$ AM14046V1

Figure 12: Quiescent current vs temperature
($I_{OUT} = 1.2 \text{ A}$)



$V_{IN}=3.8\text{V}$, $I_{OUT}=1.2\text{A}$, $V_{OUT}=3.3\text{V}$ AM14047V1

Figure 13: Shutdown current vs temperature

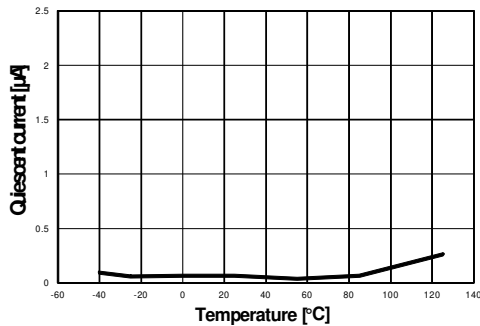

$V_{IN}=2\text{V}$, $V_{EN}=\text{GND}$, $V_{OUT}=V_{ADJ}$ AM14048V1

Figure 14: Quiescent current vs load current

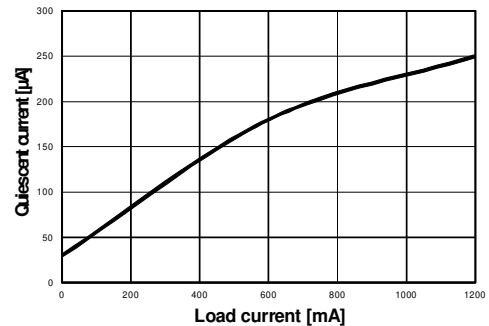

$V_{IN}=2\text{V}$, $V_{OUT}=V_{ADJ}$, $T=25^\circ\text{C}$ AM14049V1

Figure 15: Dropout voltage vs temperature
($I_{OUT} = 600 \text{ mA}$)

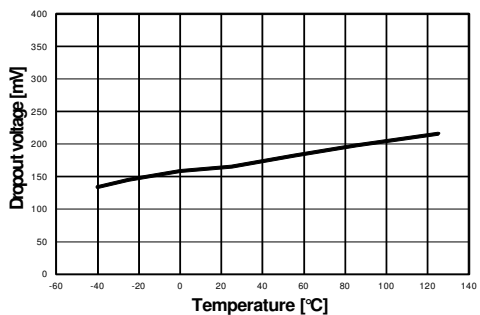

$I_{OUT}=0.6\text{A}$, $V_{OUT}=3.3\text{V}$ AM14050V1

Figure 16: Dropout voltage vs temperature
($I_{OUT} = 1.2 \text{ A}$)

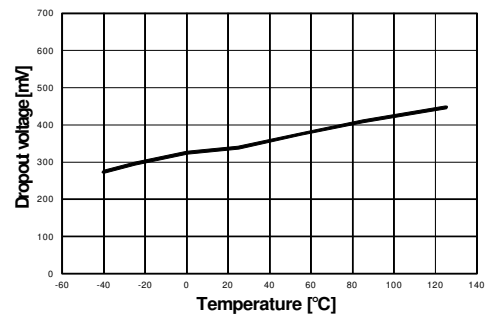

$I_{OUT}=1.2\text{A}$, $V_{OUT}=3.3\text{V}$ AM14051V1

Figure 17: Dropout voltage vs load current

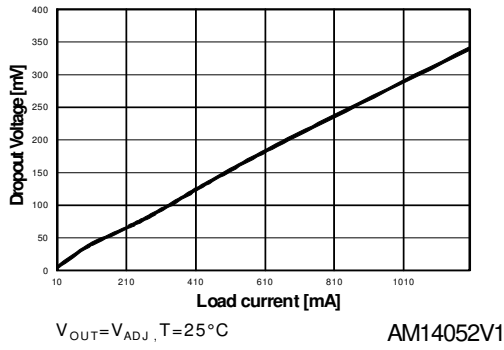

Figure 18: Short-circuit current vs input voltage

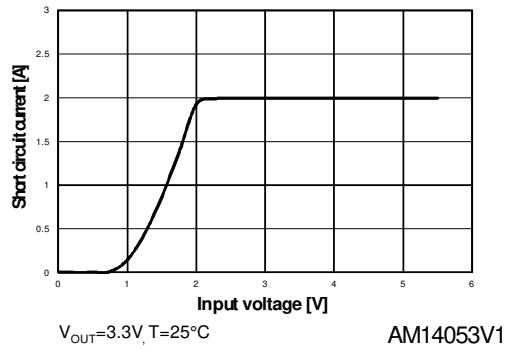

Figure 19: Enable thresholds vs temperature

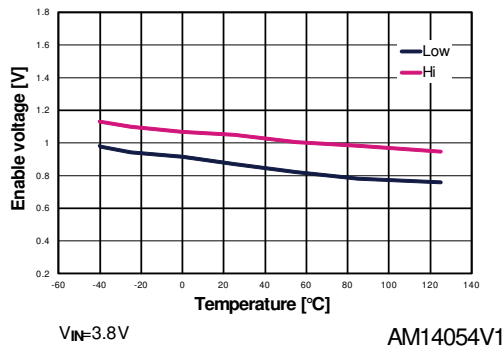

Figure 20: SVR vs frequency

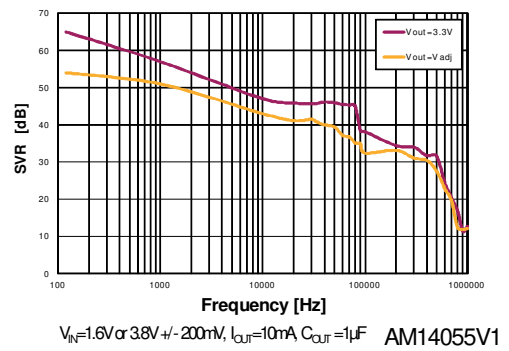

Figure 21: Output noise spectral density

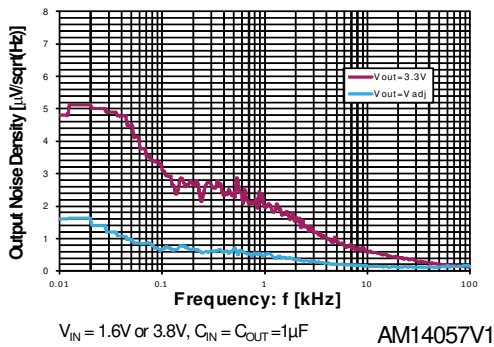

Figure 22: Stability plan vs C_{out} , ESR

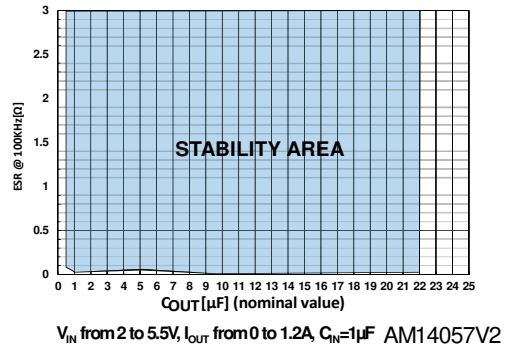
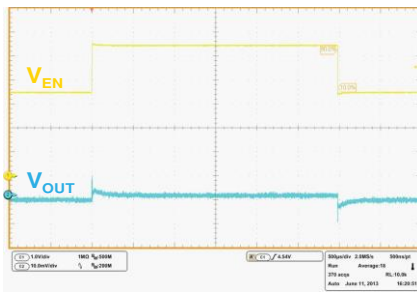
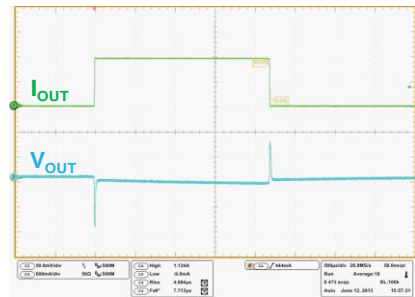

Figure 23: Line transient



V_{IN} from 3.5V to 5.5V, V_{EN} = 2V, I_{OUT} = 10mA, V_{OUT} = 3.3V, C_{OUT} = 1 μ F, t_r = 1 μ s
AM14058V1

Figure 24: Load transient



V_{IN} = V_{EF} = 4V, I_{OUT} from 5mA to 1.2A, V_{OUT} = 3.3V, t_r = 5 μ s
AM14059V1

Figure 25: Enable transient

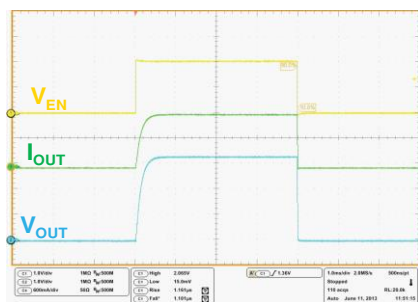

V_{IN} = 4V, V_{EN} from 0V to 2V, I_{OUT} = 1.2A, V_{OUT} = 3.3V, t_r = 1 μ s
AM14060V1

Figure 26: Turn-on time

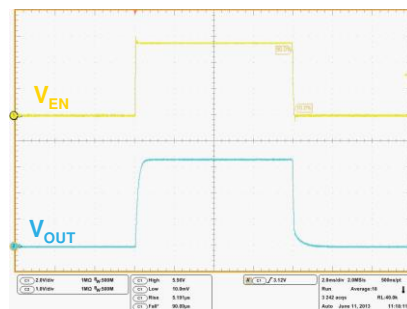

V_{IN} = V_{EF} from 0V to 5.5V, I_{OUT} = 5mA, V_{OUT} = 3.3V, t_r = 5 μ s
AM14061V1

8 Package information

In order to meet environmental requirements, ST offers these devices in different grades of ECOPACK® packages, depending on their level of environmental compliance. ECOPACK® specifications, grade definitions and product status are available at: www.st.com. ECOPACK® is an ST trademark.

8.1 DFN6 (3x3) package information

Figure 27: DFN6 (3x3) package outline

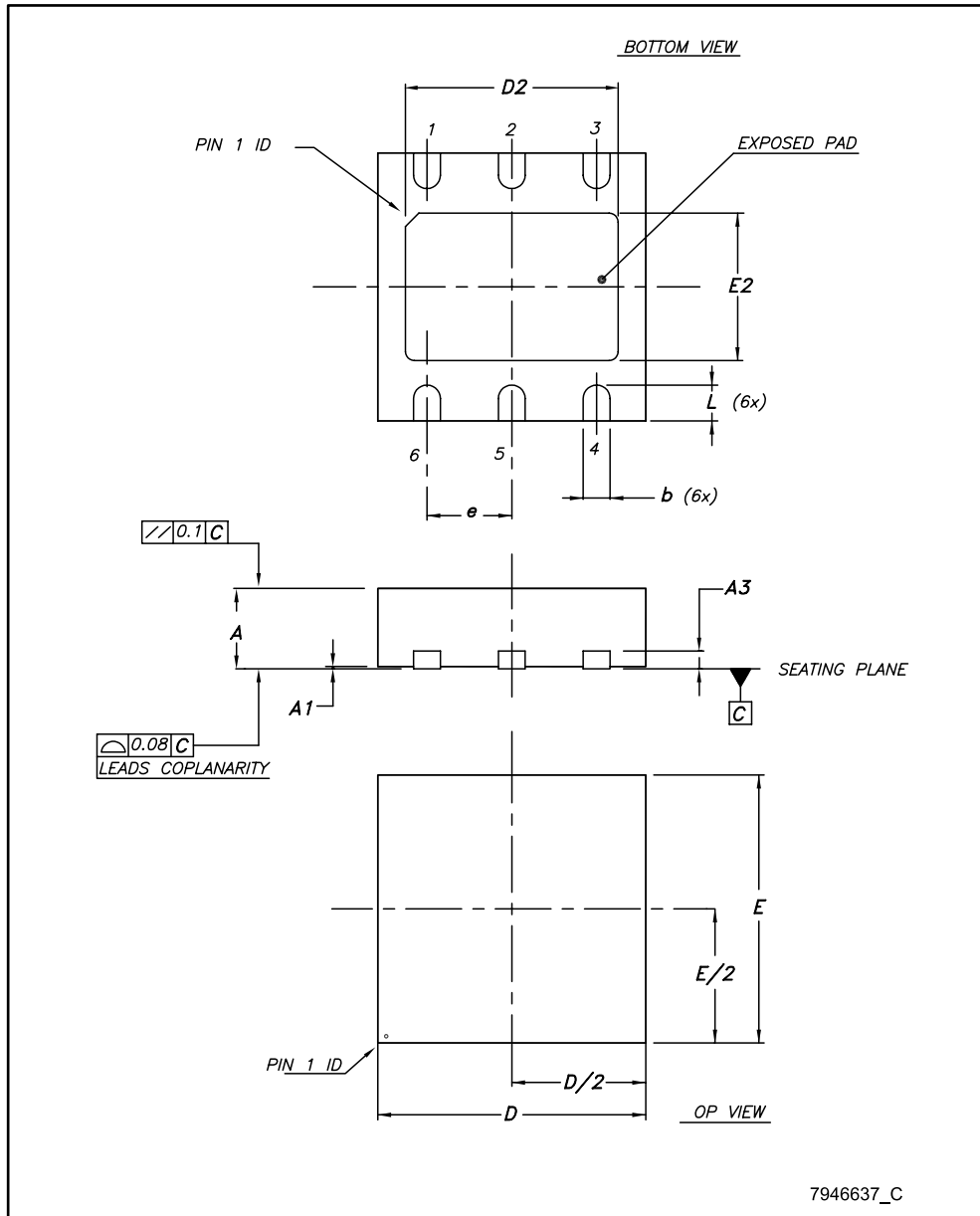
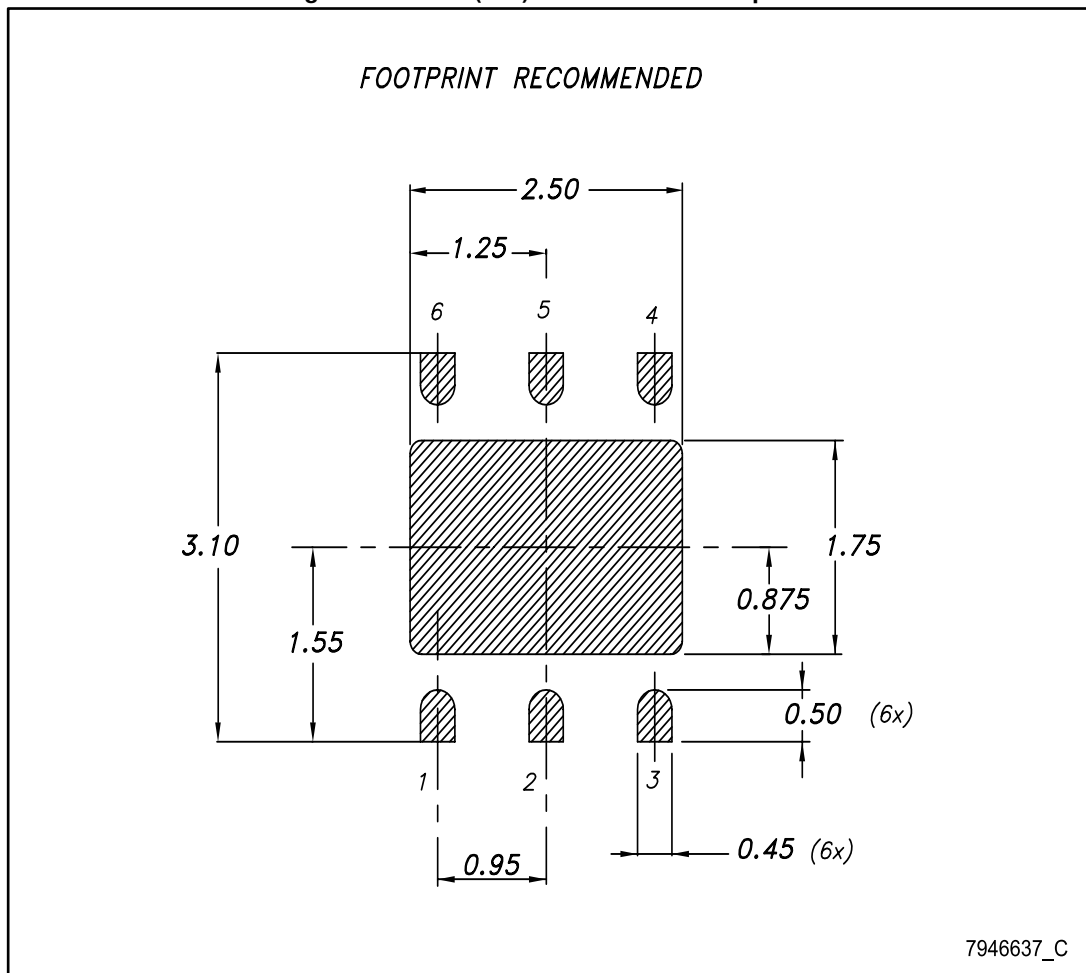

Table 6: DFN6 (3x3) mechanical data

Dim.	mm		
	Min.	Typ.	Max.
A	0.80		1
A1	0	0.02	0.05
A3		0.20	
b	0.23		0.45
D	2.90	3	3.10
D2	2.23		2.50
E	2.90	3	3.10
E2	1.50		1.75
e		0.95	
L	0.30	0.40	0.50

Figure 28: DFN6 (3x3) recommended footprint



8.2 DFN6 (3x3) packing information

Figure 29: DFN6 (3x3) tape outline

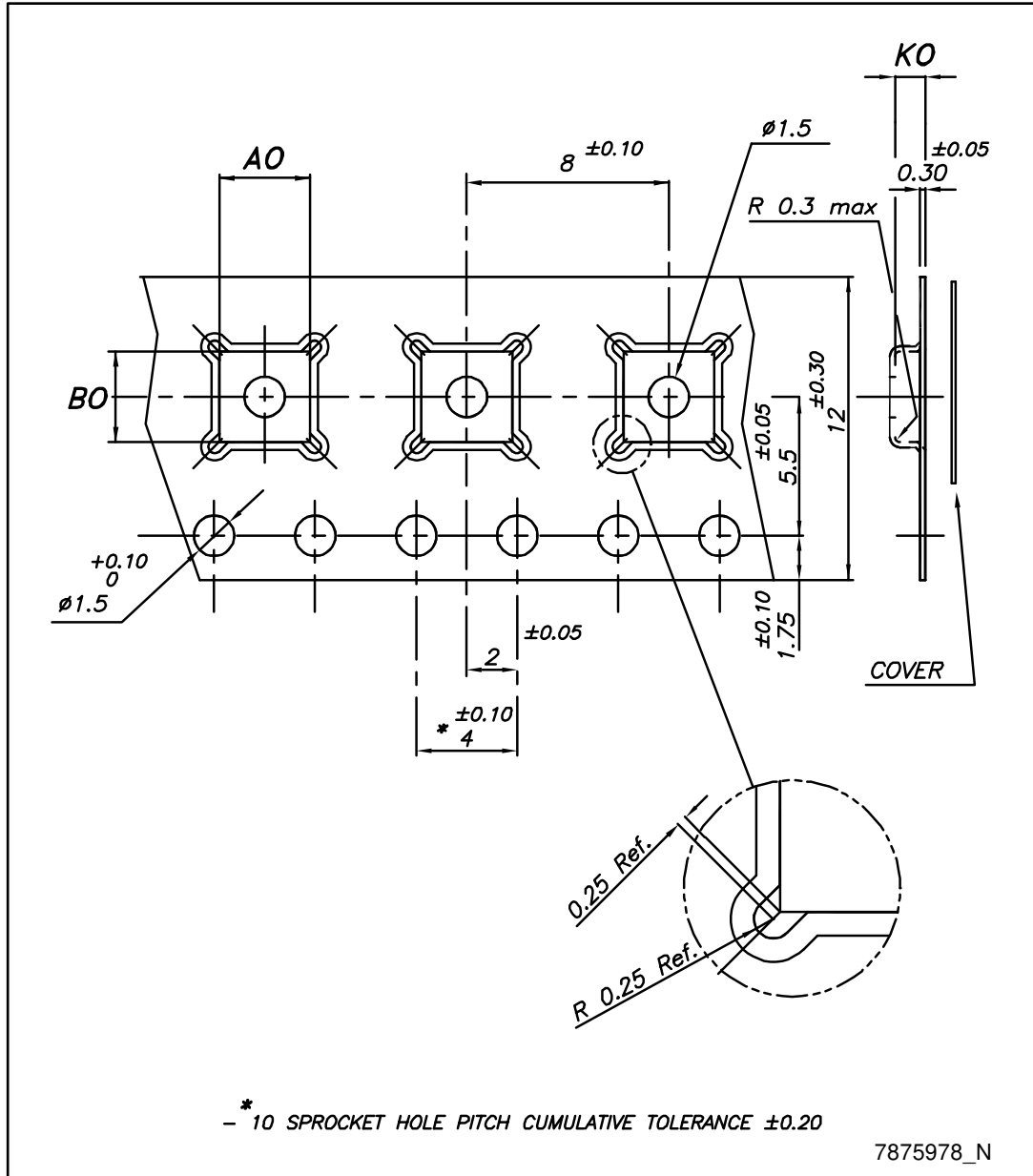

Figure 30: DFN6 (3x3) reel outline

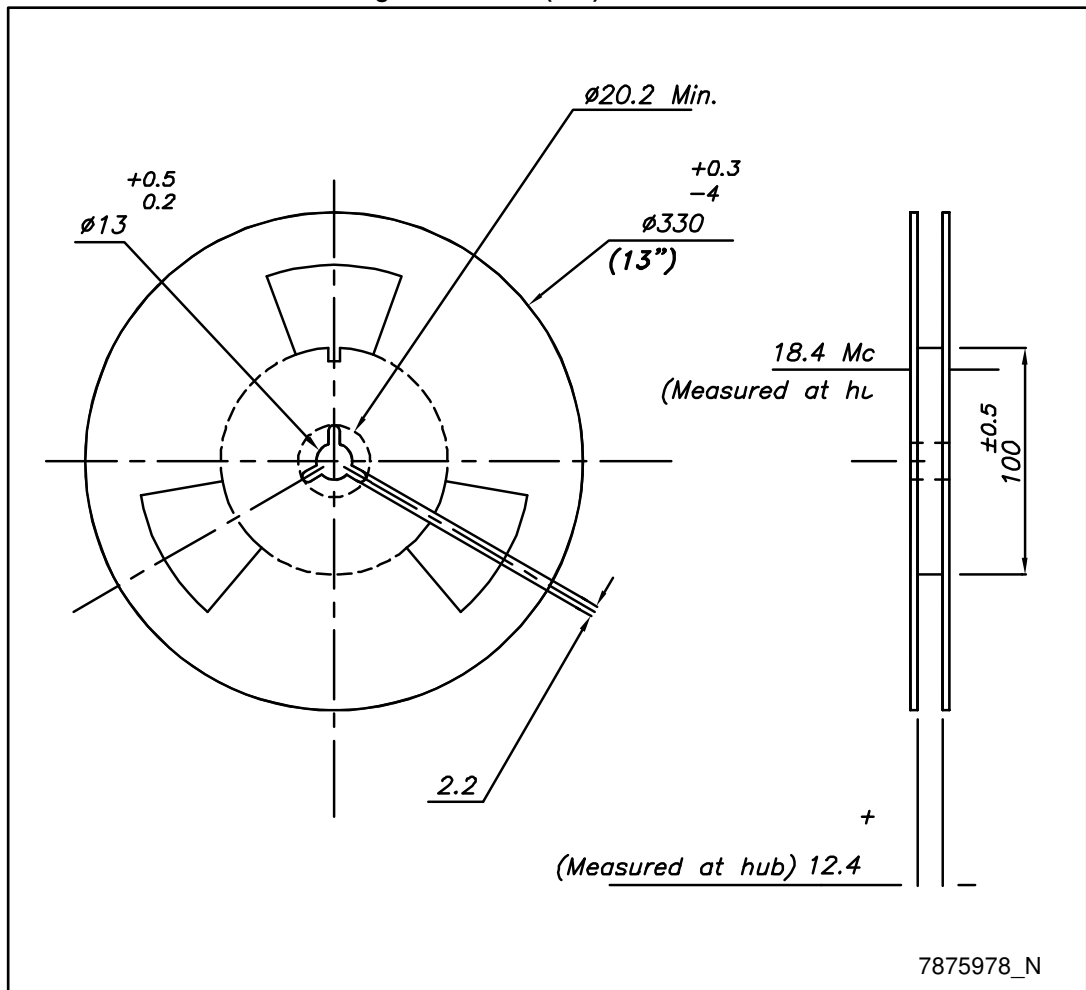

Table 7: DFN6 (3x3) tape and reel mechanical data

Dim.	mm		
	Min.	Typ.	Max.
A0	3.20	3.30	3.40
B0	3.20	3.30	3.40
K0	1	1.10	1.20

8.3 DFN6 (2x2) package information

Figure 31: DFN6 (2x2) package outline

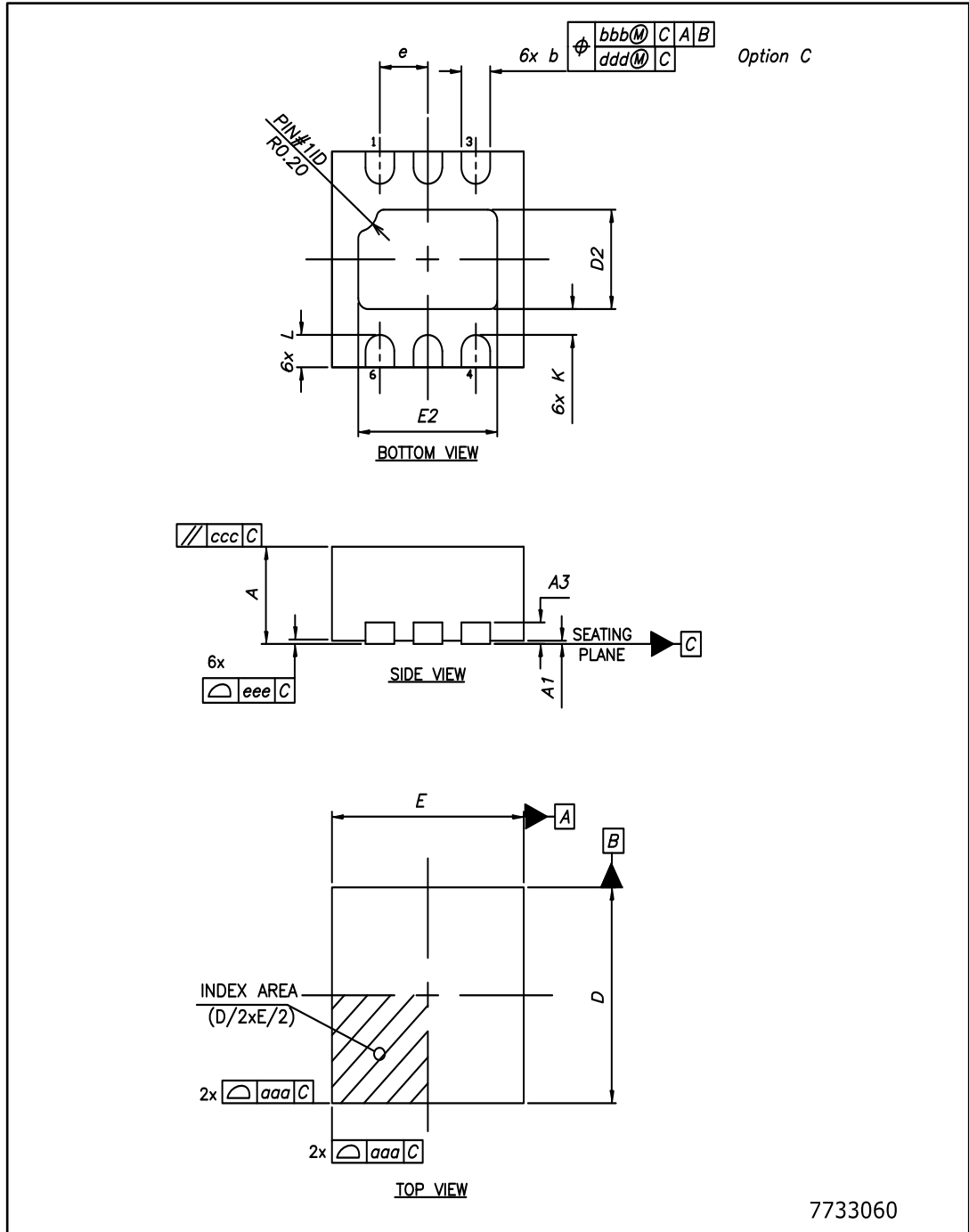
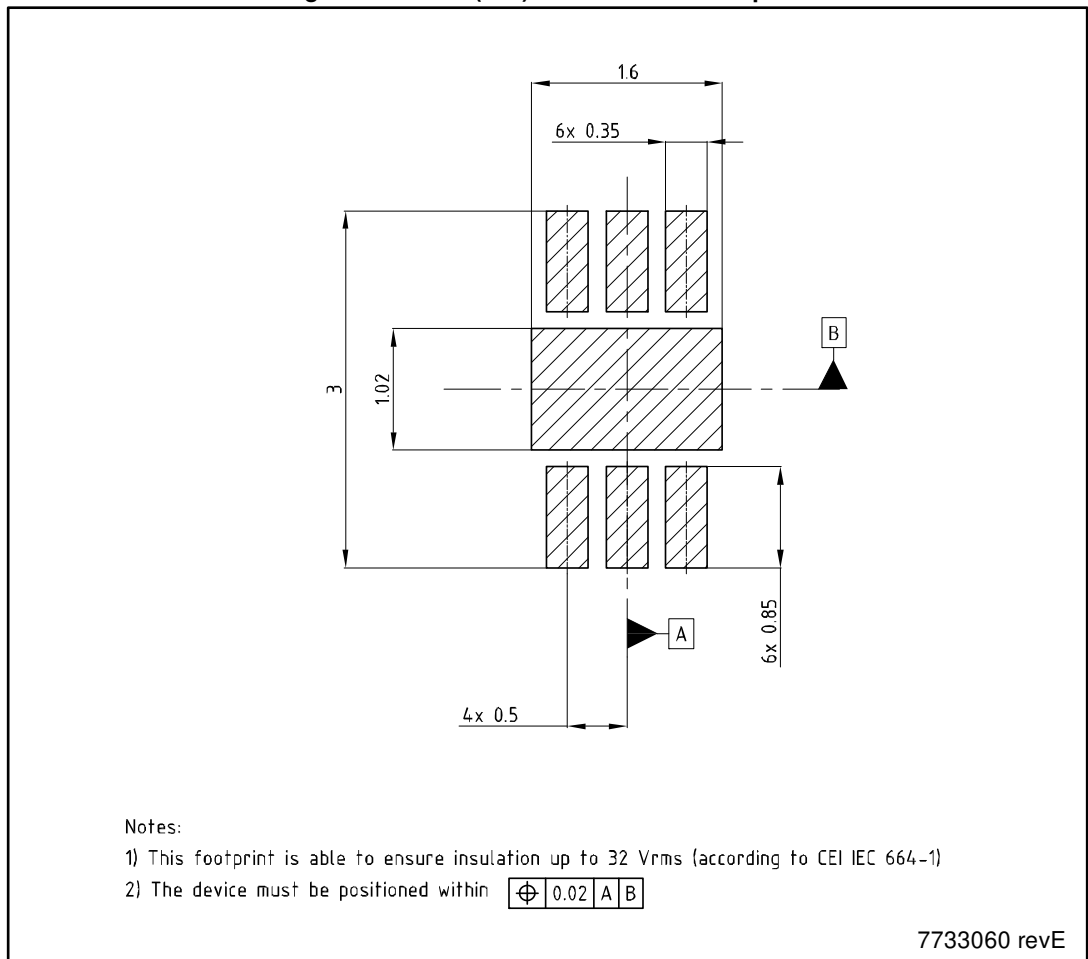

Table 8: DFN6 (2x2) mechanical data

Dim.	mm		
	Min.	Typ.	Max.
A	0.70	0.75	0.80
A1	0.00	0.02	0.05
A3	-	0.203 ref	-
b	0.25	0.30	0.35
D	-	2.00	-
E	-	2.00	-
e	-	0.50	-
D2	0.77	0.92	1.02
E2	1.30	1.45	1.55
K	0.15	-	-
L	0.20	0.30	0.40
aaa	-	0.05	-
bbb	-	0.10	-
ccc	-	0.10	-
ddd	-	0.05	-
eee	-	0.08	-

Figure 32: DFN6 (2x2) recommended footprint



8.4 DFN6 (2x2) packing information

Figure 33: DFN6 (2x2) reel outline

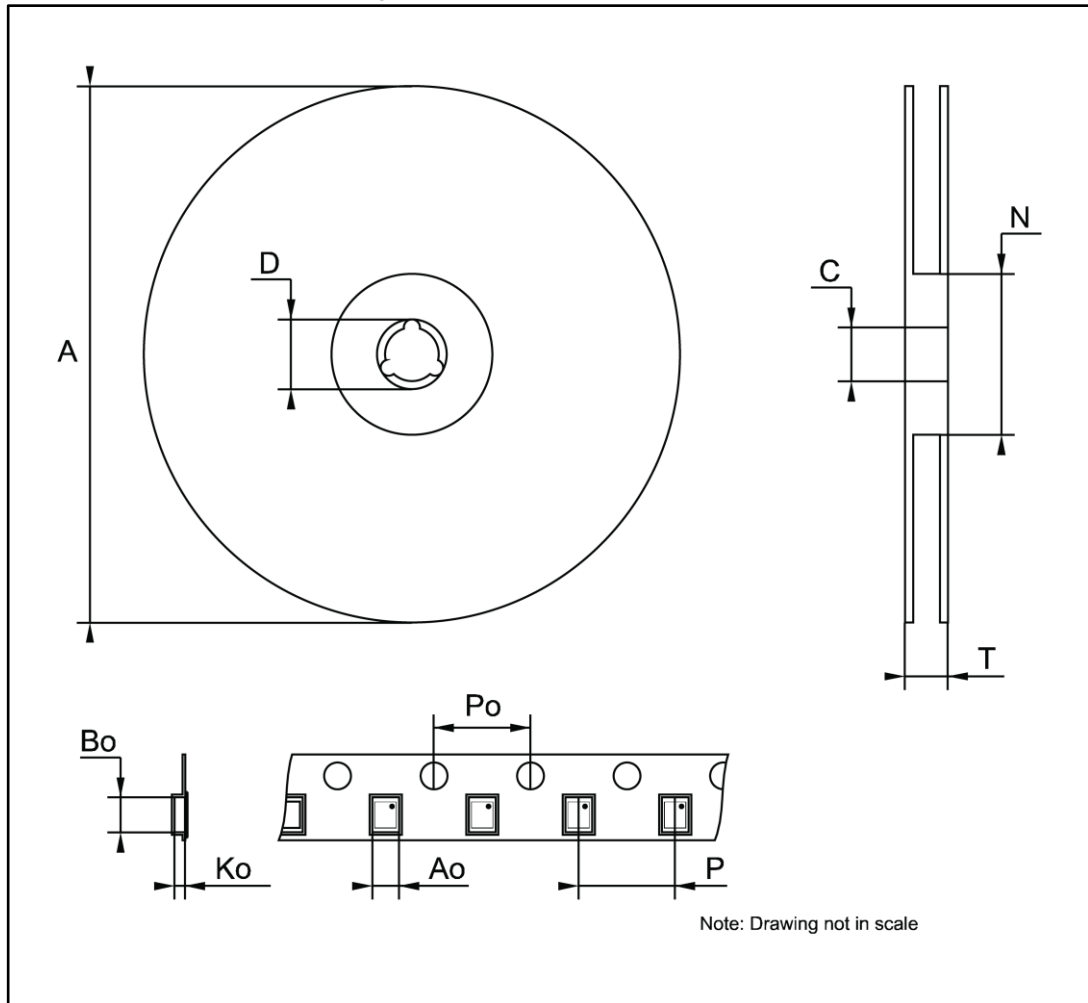

Table 9: DFN6 (2x2) tape and reel mechanical data

Dim.	mm		
	Min.	Typ.	Max.
A			180
C	12.8		13.2
D	20.2		
N	60		
T			14.4
A0		2.4	
B0		2.4	
K0		1.3	
P0		4	
P		4	

8.5 SO8-batwing package information

Figure 34: SO-8 batwing package outline

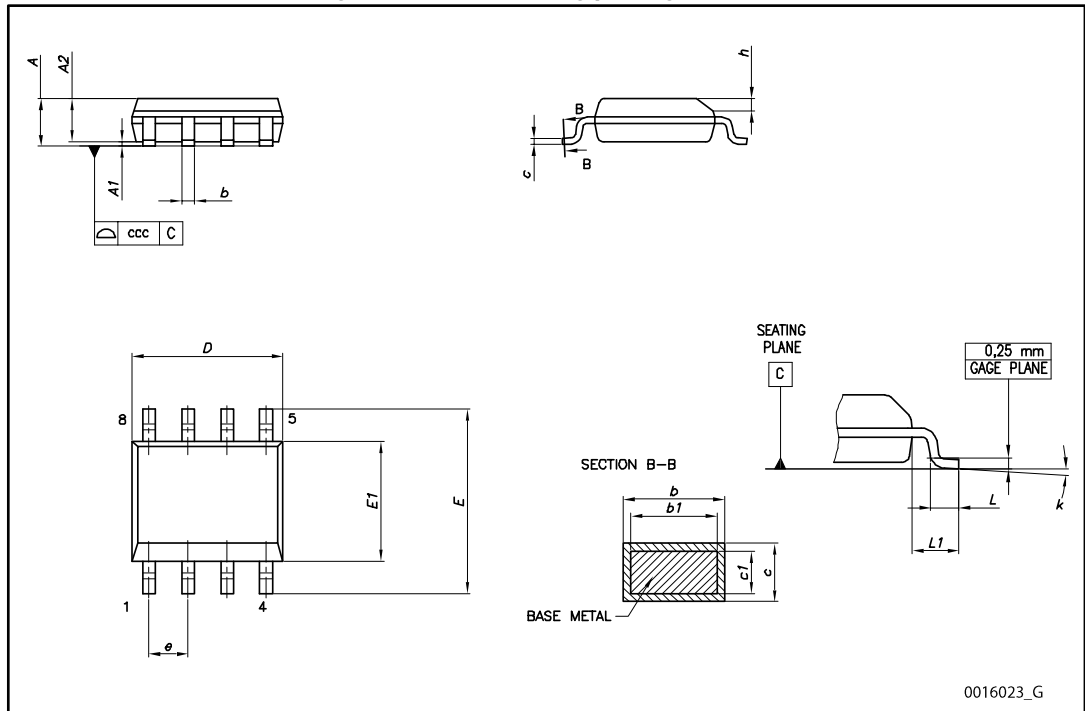
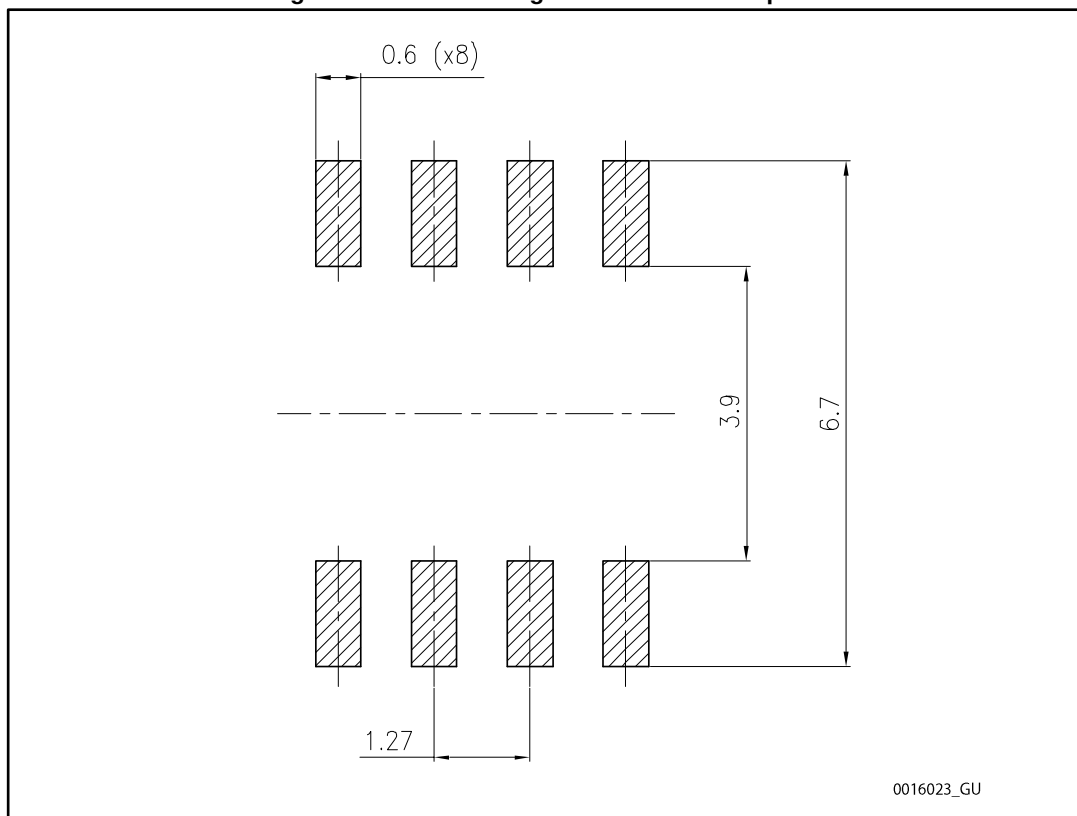

Table 10: SO-8 batwing mechanical data

Dim.	mm		
	Min.	Typ.	Max.
A			1.75
A1	0.10		0.25
A2	1.25		
b	0.31		0.51
b1	0.28		0.48
c	0.10		0.25
c1	0.10		0.23
D	4.80	4.90	5.00
E	5.80	6.00	6.20
E1	3.80	3.90	4.00
e		1.27	
h	0.25		0.50
L	0.40		1.27
L1		1.04	
L2		0.25	
k	0°		8°
ccc			0.10

Figure 35: SO-8 batwing recommended footprint



8.6 SO8-batwing packing information

Figure 36: SO8-batwing tape and reel outline

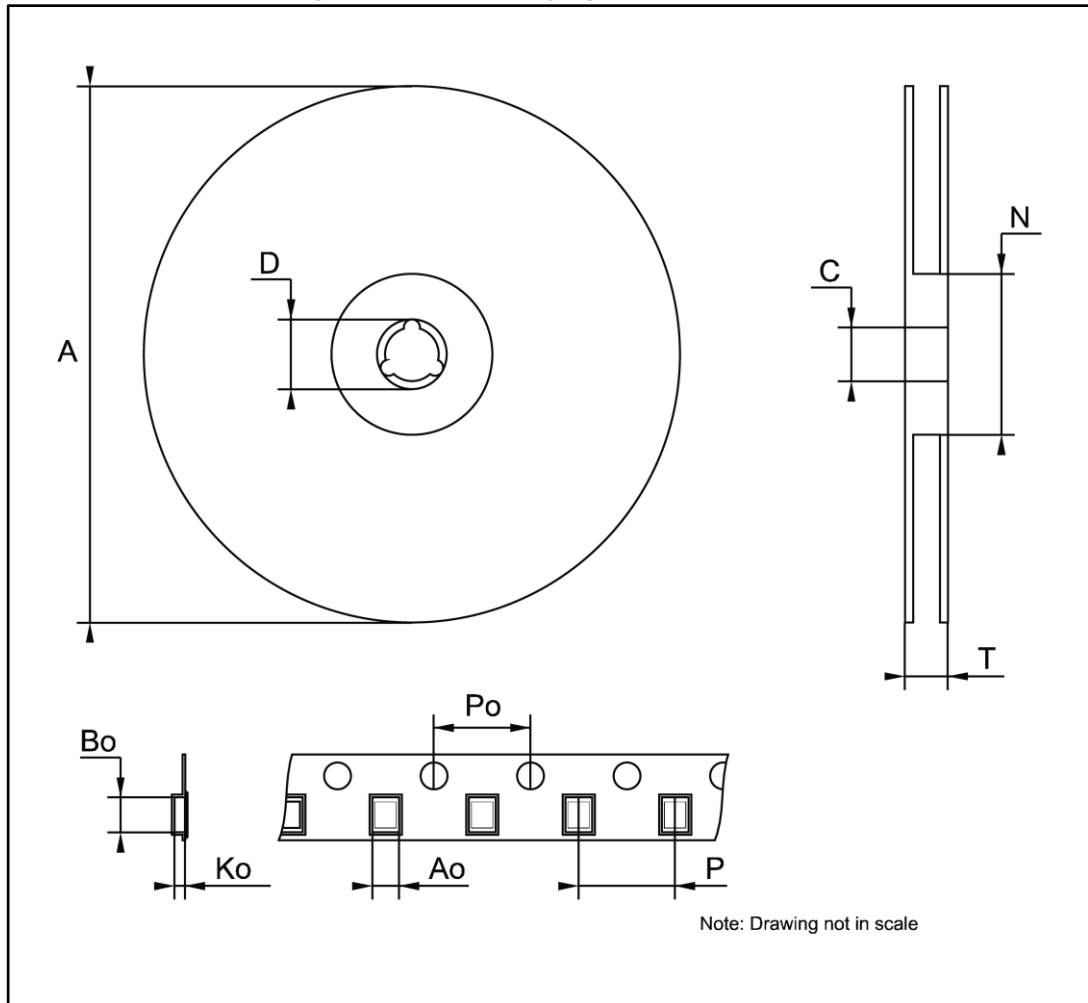

Table 11: SO8-batwing mechanical data

Dim.	mm		
	Min.	Typ.	Max.
A			330
C	12.8		13.2
D	20.2		
N	60		
T			22.4
A0	8.1		8.5
B0	5.5		5.9
K0	2.1		2.3
P0	3.9		4.1
P	7.9		8.1