



Chipsmall Limited consists of a professional team with an average of over 10 year of expertise in the distribution of electronic components. Based in Hongkong, we have already established firm and mutual-benefit business relationships with customers from,Europe,America and south Asia,supplying obsolete and hard-to-find components to meet their specific needs.

With the principle of “Quality Parts,Customers Priority,Honest Operation,and Considerate Service”,our business mainly focus on the distribution of electronic components. Line cards we deal with include Microchip,ALPS,ROHM,Xilinx,Pulse,ON,Everlight and Freescale. Main products comprise IC,Modules,Potentiometer,IC Socket,Relay,Connector.Our parts cover such applications as commercial,industrial, and automotives areas.

We are looking forward to setting up business relationship with you and hope to provide you with the best service and solution. Let us make a better world for our industry!



## Contact us

Tel: +86-755-8981 8866 Fax: +86-755-8427 6832

Email & Skype: info@chipsmall.com Web: www.chipsmall.com

Address: A1208, Overseas Decoration Building, #122 Zhenhua RD., Futian, Shenzhen, China



# Inductive Sensors

## Single or Dual Loop Detectors

### Type LD with teach-in

CARLO GAVAZZI



- Single or Dual loop detector
- Automatically adjustment of detection level
- Manual sensitivity for compensations of variations
- Easy installation via 11 pin circular plug
- Rated operational voltage: 24 VAC/DC, 115 VAC or 230 VAC
- Pulse or presence relay output
- Output 1A/250 VAC SPDT relay
- LED indication for power, relay status and loop fault
- Sensitivity boost – only LDP1
- Selectable frequency – prevents cross-talk
- Direction logic – only LDP2

## Product Description

Loop detectors for detection of vehicles. The vehicle loop detector is designed to handle all parking, drive-through and access control applications for controlling doors, gates, barriers or fences.

The principle is based on a change in the inductance within the loop when a metallic object (vehicles) is passing. The microprocessor evaluates the changes.

## Ordering Key

**LDP1 SA1 B 230**

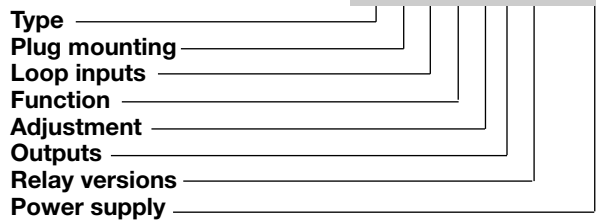

## Type Selection

Mounting	Relay	Ordering no. Supply: 24 VAC/DC	Ordering no. Supply: 115 VAC	Ordering no. Supply: 230 VAC
Single loop	SPDT	LDP1SA1BM24	LDP1SA1B115	LDP1SA1B230
Dual loop	SPST	LDP2TA2BM24	LDP2TA2B115	LDP2TA2B230

## Specifications

<b>Rated operational voltage (U<sub>B</sub>)</b>			<b>Frequency range</b>	13 - 120 kHz
Pin 2 & 1	230	195 to 265 VAC, 45 to 65 Hz	<b>Loop inductance</b>	15 - 1500 µH
	115	98 to 132 VAC, 45 to 65 Hz	<b>Operating frequency (f)</b>	
	M24	19.2 to 28.8 VAC/DC	Relay output	1 HZ
Rated insulation voltage		<2.0 kVAC (rms)	<b>Response time</b>	400 mS
Rated impulse withstand voltage		4 kV (1.2/50 µs) (line/neutral)	<b>Environment</b>	
<b>Rated operational power</b>			Overvoltage category	III (IEC 60664)
AC supply		3 VA	Degree of protection	IP 20 (IEC 60529, 60947-1)
AC/DC supply		1.5 VA / 1.5 W	Pollution degree	2 (IEC 60664/60664A, 60947-1)
<b>Power on delay (t<sub>v</sub>)</b>		< 10 sec Typ. 4 sec	<b>Temperature</b>	
<b>Outputs</b>			Operating	-40° to +70°C (-40° to +158°F)
Minimum switching current		10 mA @ 12 V	Storage	-50° to +85°C (-58° to +185°F)
Rated insulation voltage		250 VAC (rms) (cont./elec.)	<b>Housing material</b>	NORYL SE1, light grey
<b>Relay Rating (AgNi 90/10)</b>			<b>Weight</b>	
Resistive loads	AC1	µ (micro gap)	AC supply	150 g
	DC1	1 A / 250 VAC (250 VA)	AC/DC supply	85 g
Mechanical life (typical)		1 A / 30 VDC (30 W)	<b>Approvals</b>	UL508
		≥ 15 x 10 <sup>6</sup> operations	<b>CE marking</b>	Yes
		@ 18'000 imp/h		
Electrical life (typical)	AC1	> 250'000 operations		
<b>Sensitivity</b>		8 sensitivity settings available		

## Mode of Operation

### Application

The LDP Vehicle Loop Detector is based on micro-processor technology, which has enabled a large number of functions to be implemented. The functions are primarily for use in the Parking/Access Control Industry like control for gates, barriers, fences, etc. Standard operations are implemented including programmable pulse and presence option.

### Principle

The Vehicle Loop Detector is based on the inductive principle, using a coil of wire buried in the driveway and connected to the loop detector. The change in inductance will be measured as a change in frequency. The output relay activates when the loop is activated and releases again when the loop returns to a non-activated condition.

### Setup

The loop has to be in a passive condition (no object in the loop area) during start-up and adjustment. The loop detector will automatically calibrate when the reset button has been activated, which will be indicated by the yellow LED flashing. The functioning can now be checked by activating the loop with the actual object. Now the yellow LED will go on, and the output relay will be activated according to the dip-switch settings.

If the loop detector does not react, the sensitivity must be manual adjusted by means of the dip-switches.

**Important:** reset the system after changing the Dip-switch settings.

### Temperature compensation

The frequency will increase as a result of decreasing temperatures and vice versa. To compensate for this, or any other situation that courses slowly change in frequency, the LD auto tunes constantly. That means if the frequency changes slowly there will be no detection. The auto tune function compensates for both increasing or decreasing in frequency.

### Fault detection

This function is useful if the cable disconnect. The alarm will be indicated via the red LED in front of the housing. This LED is constantly lighting when the loop is open or too large and flashing when a short circuit occurs or a loop is too small.

### Sensitivity

8 sensitivity settings are available on the dip-switch-

es in front of the module, to allow flexibility in configuration and application (Compensation for variation in loop construction).

### Reset switch

The reset switch enables the detector to be manually reset during commissioning and testing. The detector will re-tune the sensing loop and become ready for vehicle detection.

### Relay output

The single loop detector has two SPDT relays – one for pulse output and one for presence output.

The dual loop detector has two SPST relays – one for each loop.

Pulse output (one shot): It is possible to select the length of the output period to 0.2s or 1 second. The pulse output can be setup to activate on detection of a vehicle or when the vehicle leaves the loop.

Presence output: The output will be activated as long as there is a vehicle parked in the loop. It will be possible to activate a filter (ON-delay of 2 seconds), which prevents a false detection from a small

or fast moving object.

### Pulse output mode

The relay activates only for a short period when the vehicle enters or leaves the loop.

### Permanent output mode

The relay will remain active as long as there is a vehicle parked in the loop.

### Pulse length

Extends the pulse length from 0.2 sec to 1 sec.

### On-delay

Prevents false detections of small or fast moving objects.

### Sense boost (only single channel loop detector)

This feature sets the undetected level to maximum sensitivity and is used to prevent loss of detection of high-bed vehicles.

### Selectable frequency

The frequency of the loop is determined by the inductance of the loop and the frequency switch setting. If the frequency switch is on, the frequency is reduced. It may be necessary to change the frequency to prevent cross talk between adjacent loops.

The frequency function will only change the frequency of one channel of the dual loop detector.

**Important:** Be careful when installing the detector next to another inductive load, as this can have an effect on the detector and cause false detections.

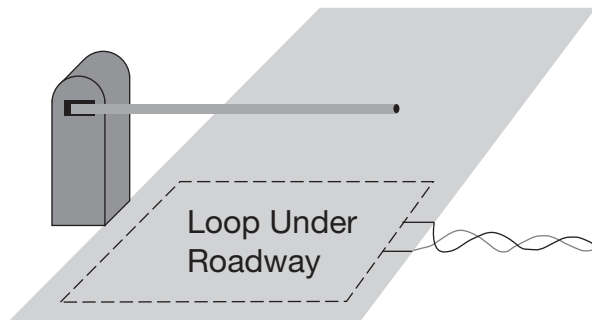

## Operation Diagram

### LDP1 / Presence and Pulse mode

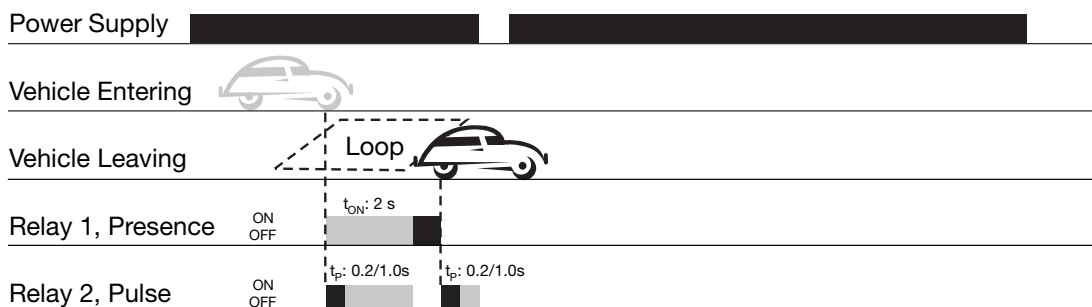

## Operation Diagram (cont.)

### LDP2 / Direction Logic Mode

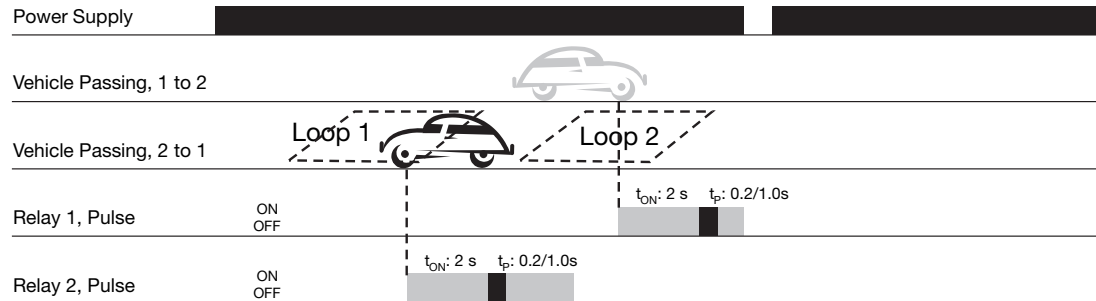

### LDP2 / Presence Mode

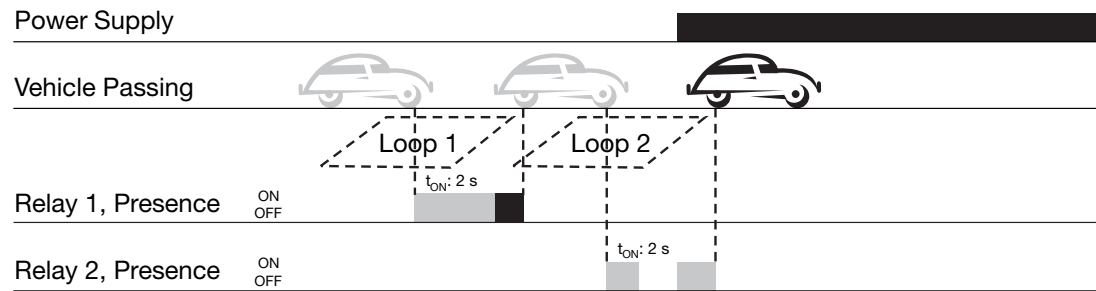

### LDP2 / Pulse Entering

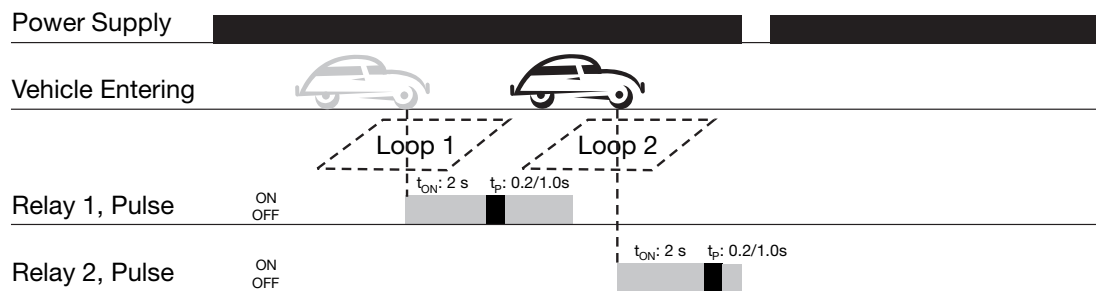

### LDP2 / Pulse Leaving

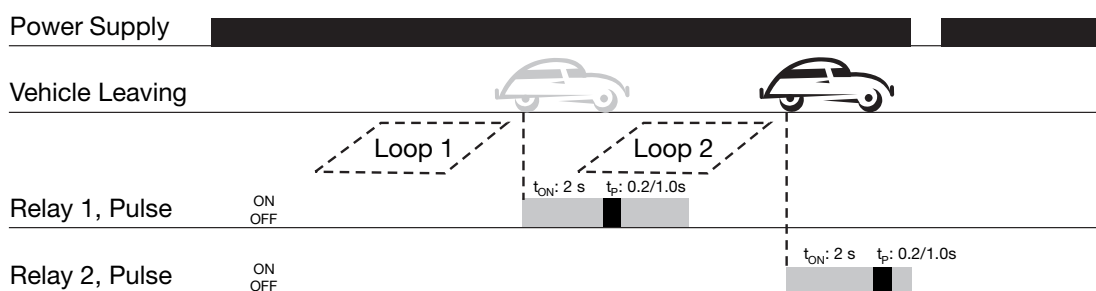



## Dimension Drawing

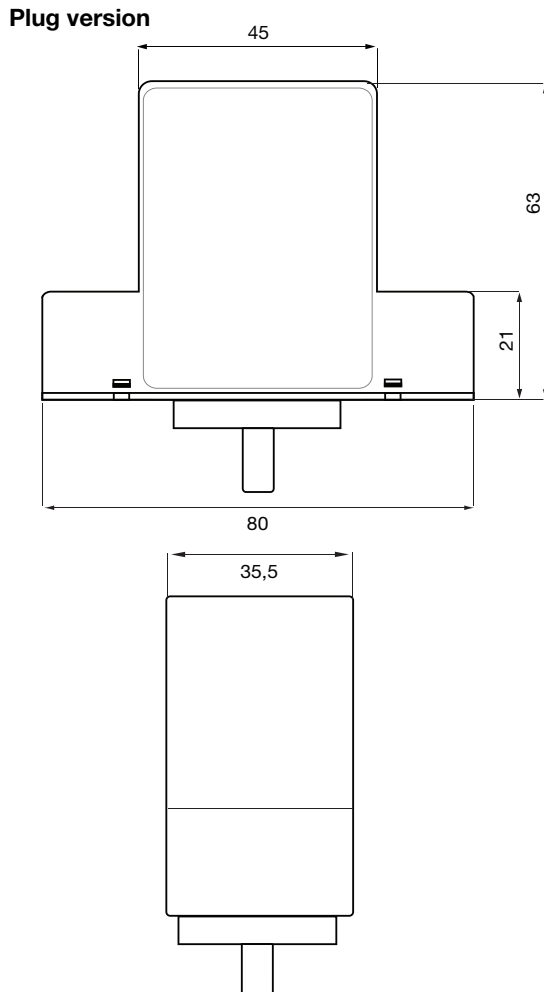

## Wiring Diagram

### LDP1

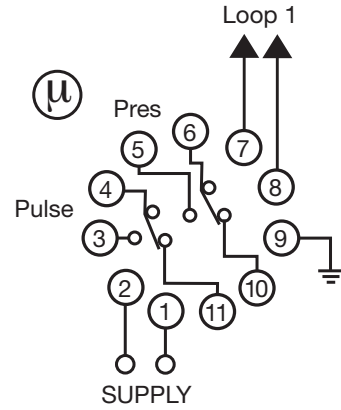

### LDP2

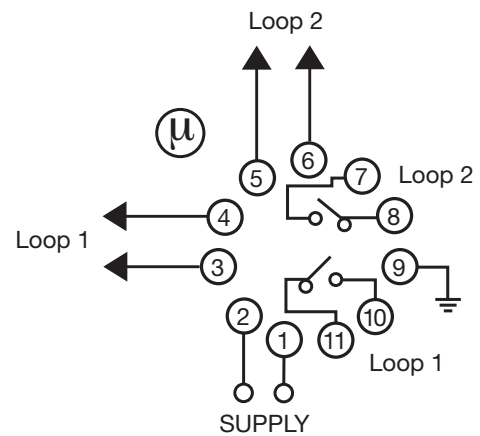

## Pin configuration

Pin n.	Single Channel Detector	Dual Channel Detector
1	Supply	Supply
2	Supply	Supply
3	Pulse relay NO	NO Loop #1
4	Pulse relay COM	Loop #1
5	Presence relay NO	Loop #2
6	Presence relay COM	Loop #2
7	Loop	Pulse/Presence relay #2 NO
8	Loop	Pulse/Presence relay #2 COM
9	Earth	Earth
10	Presence relay NC	Pulse/Presence relay #1 NO
11	Pulse relay NC	Pulse/Presence relay #1 COM

## Accessories

- 11-pole circular socket ZPD11

## Delivery Contents

- Detector
- Packaging: Carton box