



Chipsmall Limited consists of a professional team with an average of over 10 year of expertise in the distribution of electronic components. Based in Hongkong, we have already established firm and mutual-benefit business relationships with customers from,Europe,America and south Asia,supplying obsolete and hard-to-find components to meet their specific needs.

With the principle of “Quality Parts,Customers Priority,Honest Operation,and Considerate Service”,our business mainly focus on the distribution of electronic components. Line cards we deal with include Microchip,ALPS,ROHM,Xilinx,Pulse,ON,Everlight and Freescale. Main products comprise IC,Modules,Potentiometer,IC Socket,Relay,Connector.Our parts cover such applications as commercial,industrial, and automotives areas.

We are looking forward to setting up business relationship with you and hope to provide you with the best service and solution. Let us make a better world for our industry!



Contact us

Tel: +86-755-8981 8866 Fax: +86-755-8427 6832

Email & Skype: info@chipsmall.com Web: www.chipsmall.com

Address: A1208, Overseas Decoration Building, #122 Zhenhua RD., Futian, Shenzhen, China



FEATURES

- Full touch screen controller IC with up to 35 sensor channels
- Optimized for IDT's True Single-Layer Sensor with Multi-Touch capability
- 10 bit resolution in X & Y directions
- No multi-touch ghosting effect
- Two-finger multi-touch support
- 8ms (120Hz) data rate
- Supports screen sizes of 5" and less
- Low-power mode
- 5x5 40-pin TQFN (LDS7000) or 6x6 48-pin TQFN package (LDS7001)
- I²C interface and SPI interface (LDS7001) only

CUSTOMER BENEFITS

- Simplified touch screen sensor manufacturing, lowering cost of solution
- Easier (artifact-free) host-side gesture recognition
- Faster response to touch inputs
- Enables lower backlight setting, saving battery power
- Enables efficient roll-to-roll manufacturing of touch screen sensors

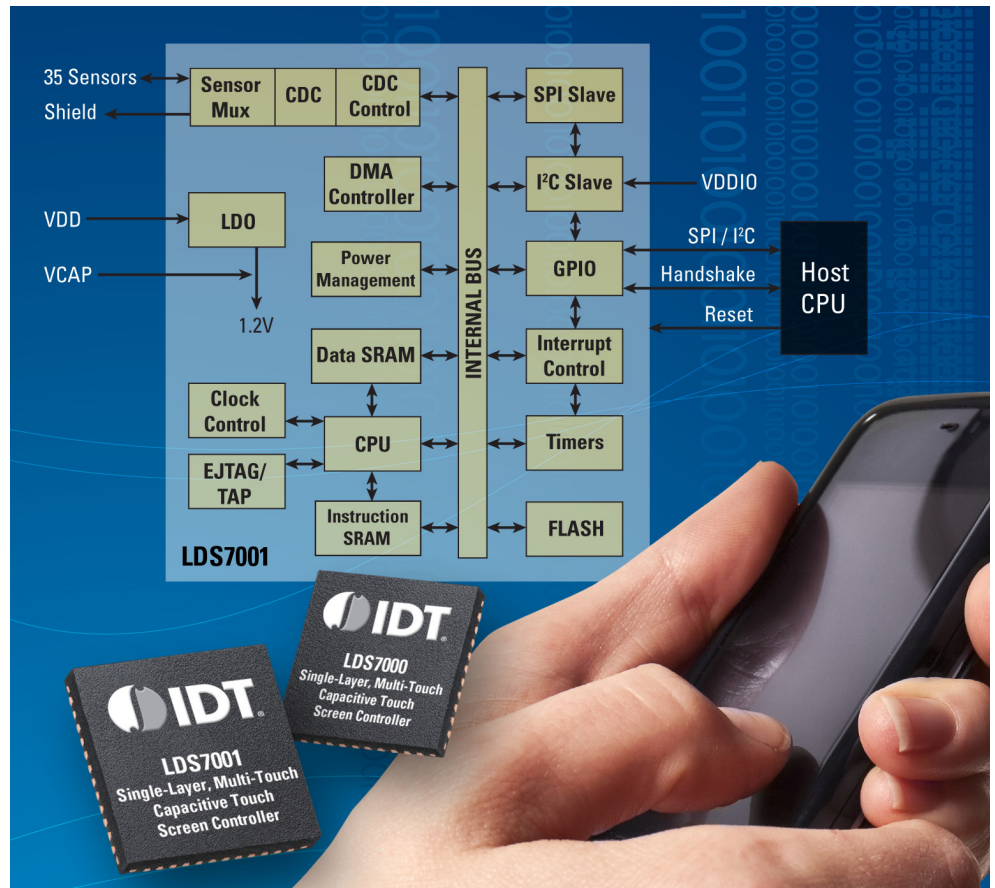

Description

The LDS700x family of devices (LDS7000 and LDS7001) are the world's first true single layer, full-touch capacitance screen devices, with multi-touch capabilities. These devices help to enhance the human-machine interface experience by supporting advanced features such as swipe, gestures, expand and squeeze. Employing a capacitance-to-digital convertor coupled with a unique and proprietary Indium-Tin-Oxide (ITO) pattern, the LDS7000 products offer best-in-class linearity and signal to noise ratio performance for all types of applications. The LDS7000 has unique built-in firmware which provides true x/y data and eliminates multi-touch ghosting effects.

Automatic on-chip calibration takes into account the effects of environmental changes such as temperature, humidity and dust and ensures to establish an accurate baseline capacitance for each sensor to ensure maximum responsiveness to true touch events.

The 40-pin LDS7000 supports 30 sensors and uses an I²C interface for communicating with the host. The 48-pin LDS7001 supports 35 sensors and is configurable to use either I²C or SPI interfaces for communicating with the host.

The LDS700x family supports supply voltages from 2.7 to 3.6V. The 48-pin LDS7001 offers General Purpose I/O (GPIO). The I²C clock and data lines support a 1.8V to 3.6V voltage interface using the V_{DDIO} pin. The SPI interface supports 2.7 to 3.6V operation and V_{DDIO} voltage must be the same as V_{DD}.

APPLICATIONS

- Mobile handsets, personal media players
- Portable navigation devices
- Remote controls
- Office equipment, multi-function printers
- Set top boxes
- Home appliances
- Brown goods
- Industrial controls
- Digital cameras
- Consumer products

FUNCTIONAL BLOCK DIAGRAMS

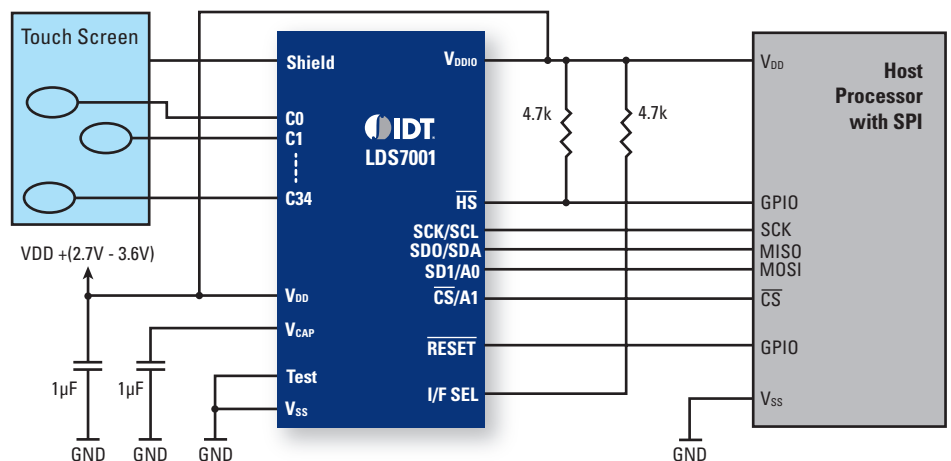
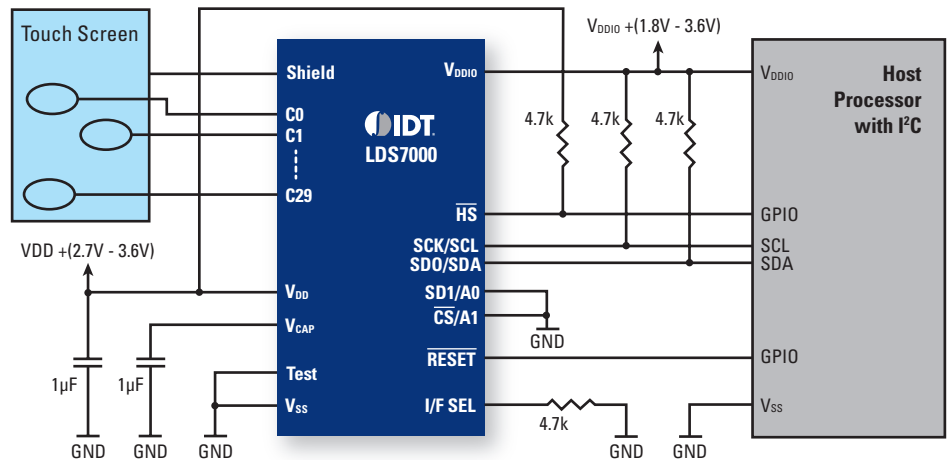

PRODUCT SPECIFICATIONS

Part Number	Touch Sensors	SPI Interface	I²C Interface	GPIO's	Package
LDS7000	30	-	Yes	0	5 x 5 x 0.75mm 40-pin TQFN
LDS7001	35	Yes	Yes	1	6 x 6 x 0.75mm 48-pin TQFN

Discover what IDT know-how can do for you:

www.IDT.com/go/Touch