



Chipsmall Limited consists of a professional team with an average of over 10 year of expertise in the distribution of electronic components. Based in Hongkong, we have already established firm and mutual-benefit business relationships with customers from,Europe,America and south Asia,supplying obsolete and hard-to-find components to meet their specific needs.

With the principle of “Quality Parts,Customers Priority,Honest Operation,and Considerate Service”,our business mainly focus on the distribution of electronic components. Line cards we deal with include Microchip,ALPS,ROHM,Xilinx,Pulse,ON,Everlight and Freescale. Main products comprise IC,Modules,Potentiometer,IC Socket,Relay,Connector.Our parts cover such applications as commercial,industrial, and automotives areas.

We are looking forward to setting up business relationship with you and hope to provide you with the best service and solution. Let us make a better world for our industry!



Contact us

Tel: +86-755-8981 8866 Fax: +86-755-8427 6832

Email & Skype: info@chipsmall.com Web: www.chipsmall.com

Address: A1208, Overseas Decoration Building, #122 Zhenhua RD., Futian, Shenzhen, China



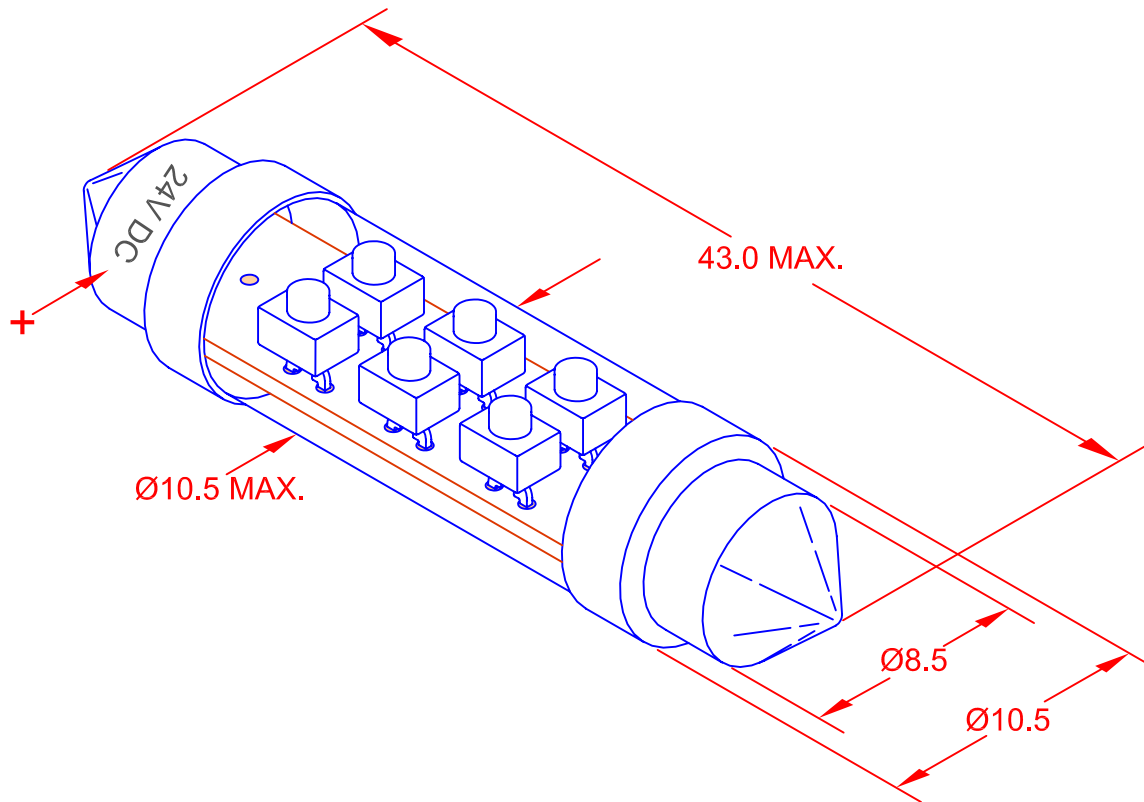

NOTES:

1. LED includes integrated diode for reverse voltage protection.
2. LED includes integrated resistor for current limiting.

TYPICAL ELECTRICAL & OPTICAL OPERATING CHARACTERISTICS

(Ta = 25 degree C)

PART NUMBER	EMITTING COLOR	AMPERAGE mA	VOLTAGE Vdc	LUMENS	COLOR COORDINATES
LE-0603-04R	RED	13mA	24.0	2.00	630nm
LE-0603-04Y	YELLOW	12mA	24.0	2.00	595nm
LE-0603-04G	GREEN	6mA	24.0	9.00	525nm
LE-0603-04B	BLUE	11mA	24.0	2.00	470nm
LE-0603-04W	WHITE	9mA	24.0	10.00	x = 0.29 y = 0.28

H CHANGE AMPERATE RATINGS 12/8/10 G CHANGE DIA. TO 10.5 MAX. 11/10/09 F CHANGE mA FROM 20 TO 12 10/29/09 E CHANGE MOL FROM 42.0 MAX. TO 43.0 MAX. 1/22/09 D CHANGE CHARTS ADD NOTES 8/25/08 C ADD ELECT & OPTICAL INFO 3/9/07 B ADD + MARKING-24V DC 10/3/06 A CHNG. 04B MSCP TO .14 7/24/06 ENGR. RELEASE & CANCEL PL-0603-04-1 TO -5 7/5/06			METRIC THIRD ANGLE PROJECTION		DIMENSIONS ARE IN MILLIMETERS TOLERANCE UNLESS OTHERWISE SPECIFIED 1 PL +/- 0.2 2 PL +/- 0 ANGLE +/- 0		JKL COMPONENTS CORPORATION			
REV. NO. DESCRIPTION/ECO NUMBER APPV'D DATE			DRAWN BY L. WENGSTROM APPV'D BY L.R. DATE 12/8/10		SIZE A	FSCM NO. 55335	DRAWING NO. LE-0603-04			
- CAD DRAWING - MANUAL REVISIONS NOT PERMITTED			SCALE NONE	RELEASED DATE 7/5/06	REVISION DATE 12/8/10	REV. NO. H	SHEET 1 OF 1			
TITLE LED FESTOON LAMP										