



Chipsmall Limited consists of a professional team with an average of over 10 year of expertise in the distribution of electronic components. Based in Hongkong, we have already established firm and mutual-benefit business relationships with customers from,Europe,America and south Asia,supplying obsolete and hard-to-find components to meet their specific needs.

With the principle of “Quality Parts,Customers Priority,Honest Operation,and Considerate Service”,our business mainly focus on the distribution of electronic components. Line cards we deal with include Microchip,ALPS,ROHM,Xilinx,Pulse,ON,Everlight and Freescale. Main products comprise IC,Modules,Potentiometer,IC Socket,Relay,Connector.Our parts cover such applications as commercial,industrial, and automotives areas.

We are looking forward to setting up business relationship with you and hope to provide you with the best service and solution. Let us make a better world for our industry!



## Contact us

Tel: +86-755-8981 8866 Fax: +86-755-8427 6832

Email & Skype: info@chipsmall.com Web: www.chipsmall.com

Address: A1208, Overseas Decoration Building, #122 Zhenhua RD., Futian, Shenzhen, China



# LF347

## Quad Operational Amplifier (JFET)

### Features

- Low input bias current
- High input impedance
- Wide gain bandwidth: 4 MHz Typ.
- High slew rate: 13 V/μs Typ.

### Description

The LF347 is a high speed quad JFET input operational amplifier. This feature high input impedance, wide bandwidth, high slew rate, and low input offset voltage and bias current. LF347 may be used in circuits requiring high input impedance. High slew rate and wide bandwidth, low input bias current.

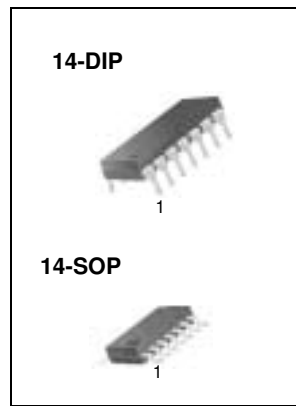

### Internal Block Diagram

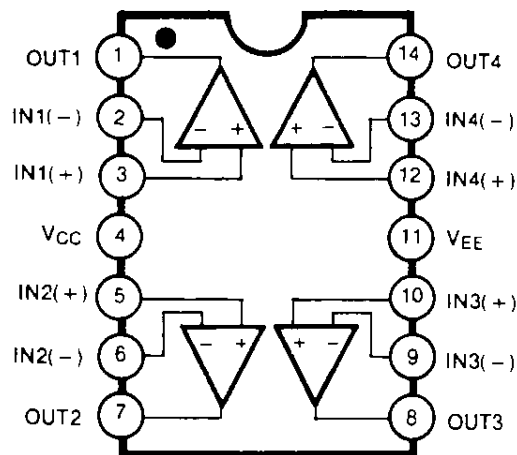

## Schematic Diagram

(One Section Only)

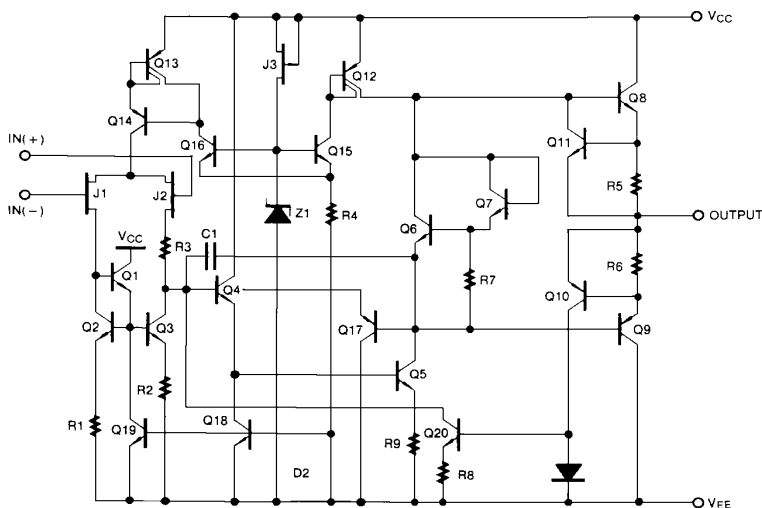

## Absolute Maximum Ratings

Parameter	Symbol	Value	Unit
Supply Voltage	V <sub>CC</sub>	±18	V
Differential Input Voltage	V <sub>I(DIFF)</sub>	30	V
Input Voltage Range	V <sub>I</sub>	±15	V
Output Short Circuit Duration	-	Continuous	-
Power Dissipation	P <sub>D</sub>	570	mW
Operating Temperature Range	T <sub>OPR</sub>	0 ~ + 70	°C
Storage Temperature Range	T <sub>STG</sub>	-65 ~ + 150	°C

## Electrical Characteristics

(VCC= +15V, VEE= -15V, TA=25 °C, unless otherwise specified)

Parameter	Symbol	Conditions	LF347			Unit
			Min.	Typ.	Max.	
Input Offset Voltage	V <sub>IO</sub>	R <sub>S</sub> = 10KΩ Note 1	-	5	10	mV
			-	-	13	
Input Offset Voltage Drift(Note2)	ΔV <sub>IO</sub> /ΔT	R <sub>S</sub> = 10KΩ	-	10	-	μV/°C
Input Offset Current	I <sub>IO</sub>	Note 1	-	25	100	pA
			-	-	4	nA
Input Bias Current	I <sub>BIAS</sub>	Note 1	-	50	200	pA
			-	-	8	nA
Large Signal Voltage Gain	G <sub>V</sub>	R <sub>L</sub> = 2KΩ V <sub>O(P-P)</sub> = ±10V Note 1	25	100	-	V/mV
			15	-	-	
Output Voltage Swing	V <sub>O(PP)</sub>	R <sub>L</sub> = 10KΩ	±12	±13.5	-	V
Input Voltage Range	V <sub>I(R)</sub>	-	±11	+15 -12	-	V
Common-Mode Rejection Ratio	CMRR	R <sub>S</sub> ≤ 10KΩ	80	100	-	dB
Power Supply Rejection Ratio	PSRR	R <sub>S</sub> ≤ 10KΩ	80	100	-	dB
Input Resistance	R <sub>I</sub>	-	-	10 <sup>12</sup>	-	Ω
Supply Current	I <sub>CC</sub>	-	-	7.2	11	mA
Slew Rate	SR	-	-	13	-	V/μS
Gain Bandwidth Product(Note2)	GBW	-	-	4	-	MHz
Channel Separation	CS	f = 1Hz ~ 20KHz (input referenced)	-	120	-	dB
Equivalent Input Noise Voltage	e <sub>N</sub>	R <sub>S</sub> = 100Ω f = 1KHz	-	20	-	nV/ √Hz
Equivalent Input Noise Current	I <sub>N</sub>	f = 1KHz	-	0.01	-	pA/√Hz

### Note :

1. LF347 : 0 ≤ T<sub>A</sub> ≤ +70 °C
2. Guaranteed by design

# Mechanical Dimensions

## Package

Dimensions in millimeters

### 14-DIP

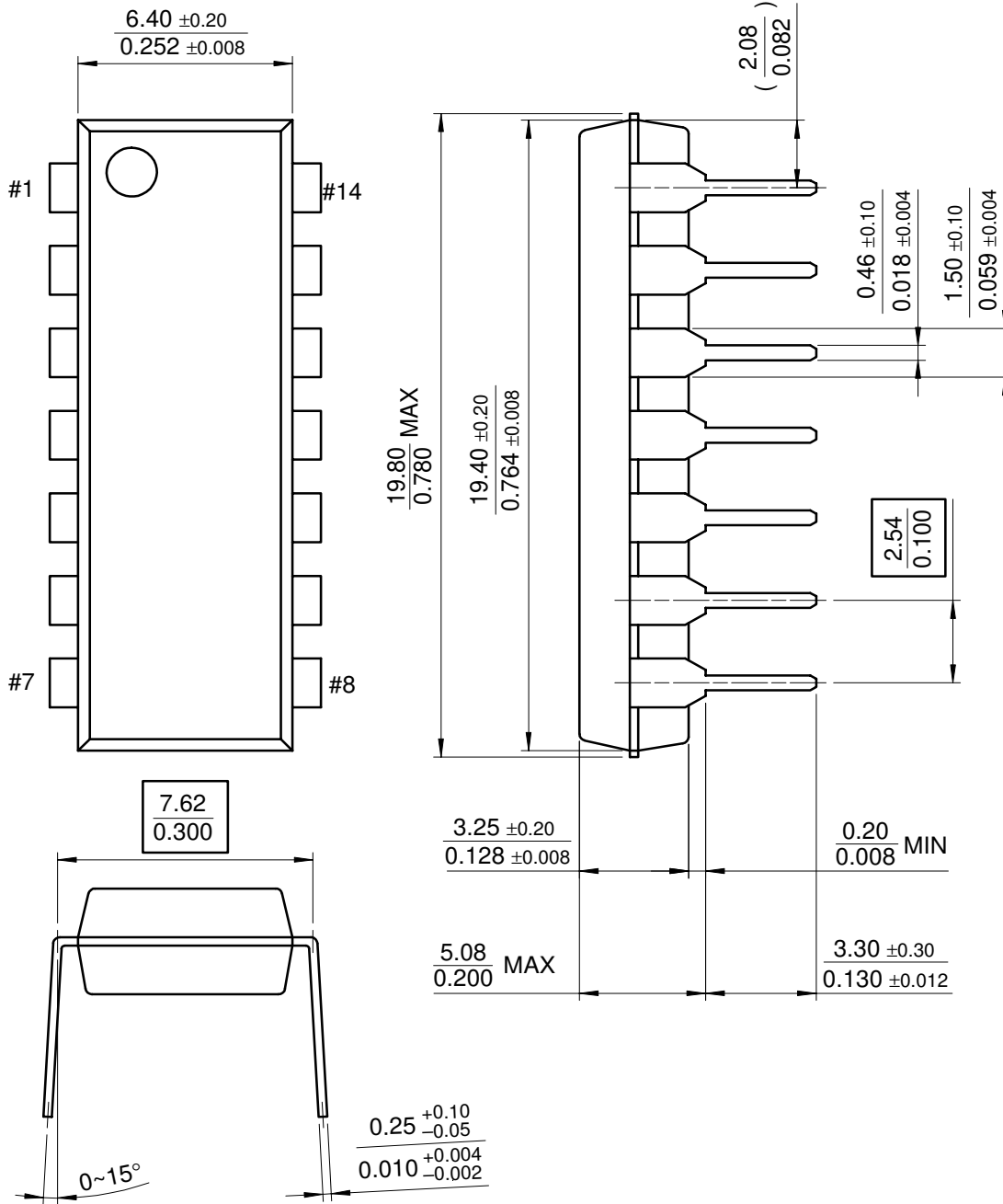

**Mechanical Dimensions** (Continued)

Package

Dimensions in millimeters

**14-SOP**

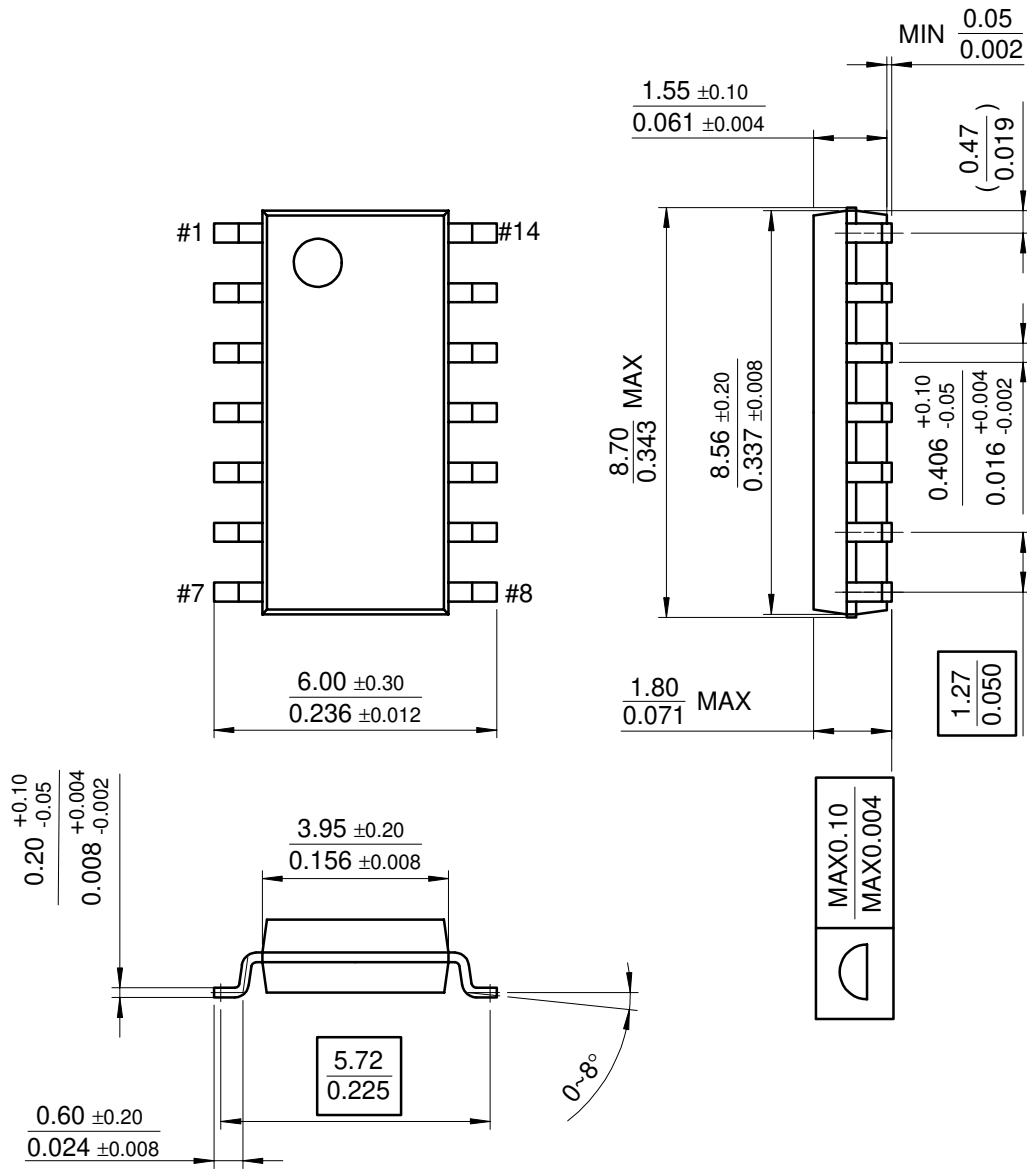

## Ordering Information

Product Number	Package	Operating Temperature
LF347N	14-DIP	0 ~ + 70°C
LF347M	14-SOP	

### DISCLAIMER

FAIRCHILD SEMICONDUCTOR RESERVES THE RIGHT TO MAKE CHANGES WITHOUT FURTHER NOTICE TO ANY PRODUCTS HEREIN TO IMPROVE RELIABILITY, FUNCTION OR DESIGN. FAIRCHILD DOES NOT ASSUME ANY LIABILITY ARISING OUT OF THE APPLICATION OR USE OF ANY PRODUCT OR CIRCUIT DESCRIBED HEREIN; NEITHER DOES IT CONVEY ANY LICENSE UNDER ITS PATENT RIGHTS, NOR THE RIGHTS OF OTHERS.

### LIFE SUPPORT POLICY

FAIRCHILD'S PRODUCTS ARE NOT AUTHORIZED FOR USE AS CRITICAL COMPONENTS IN LIFE SUPPORT DEVICES OR SYSTEMS WITHOUT THE EXPRESS WRITTEN APPROVAL OF THE PRESIDENT OF FAIRCHILD SEMICONDUCTOR CORPORATION. As used herein:

1. Life support devices or systems are devices or systems which, (a) are intended for surgical implant into the body, or (b) support or sustain life, and (c) whose failure to perform when properly used in accordance with instructions for use provided in the labeling, can be reasonably expected to result in a significant injury of the user.
2. A critical component in any component of a life support device or system whose failure to perform can be reasonably expected to cause the failure of the life support device or system, or to affect its safety or effectiveness.