



Chipsmall Limited consists of a professional team with an average of over 10 year of expertise in the distribution of electronic components. Based in Hongkong, we have already established firm and mutual-benefit business relationships with customers from,Europe,America and south Asia,supplying obsolete and hard-to-find components to meet their specific needs.

With the principle of “Quality Parts,Customers Priority,Honest Operation,and Considerate Service”,our business mainly focus on the distribution of electronic components. Line cards we deal with include Microchip,ALPS,ROHM,Xilinx,Pulse,ON,Everlight and Freescale. Main products comprise IC,Modules,Potentiometer,IC Socket,Relay,Connector.Our parts cover such applications as commercial,industrial, and automotives areas.

We are looking forward to setting up business relationship with you and hope to provide you with the best service and solution. Let us make a better world for our industry!



## Contact us

Tel: +86-755-8981 8866 Fax: +86-755-8427 6832

Email & Skype: info@chipsmall.com Web: www.chipsmall.com

Address: A1208, Overseas Decoration Building, #122 Zhenhua RD., Futian, Shenzhen, China



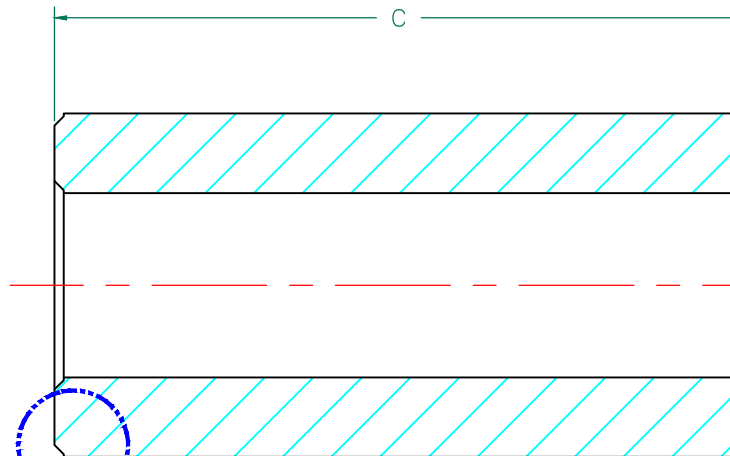
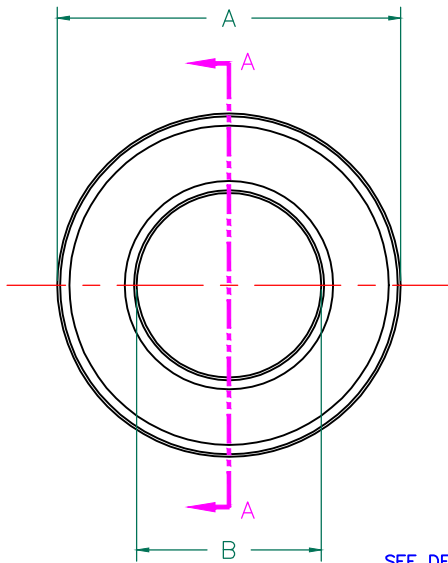

SCALE DRAWING 1:1

LFB095051-000

**UNCONTROLLED DOCUMENT**

IMPEDANCE ( Z ) NET<sup>SEE NOTE 1</sup>

FREQUENCY	500 KHz	1 MHz	5 MHz
NOMINAL (REF.) 1 TURN	36 Ω	63 Ω	86 Ω
MINIMUM (SPEC.) <sub>1 TURN</sub>	- Ω	47 Ω	- Ω
NOMINAL (REF.) 2 TURNS	150 Ω	240 Ω	340 Ω
NOMINAL (REF.) 3 TURNS	350 Ω	540 Ω	480 Ω

TEST CRITERIA

METER HP4396A OR EQUIVALENT  
 FIXTURE HP16092A OR EQUIVALENT

NOTES: UNLESS OTHERWISE SPECIFIED

- NET IMPEDANCE IS IMPEDANCE OF THE FERRITE CORE ONLY. ALL IMPEDANCE CONTRIBUTION FROM TEST WIRE AND FIXTURES HAS BEEN REMOVED.
- COSMETIC SPECIFICATION REFER TO WI-QA-038.

SEE DETAIL "A"

**SECTION A-A**

Z vs. FREQUENCY  
 1 TURN, 2, AND 3 TURNS  
 (REF. ONLY)

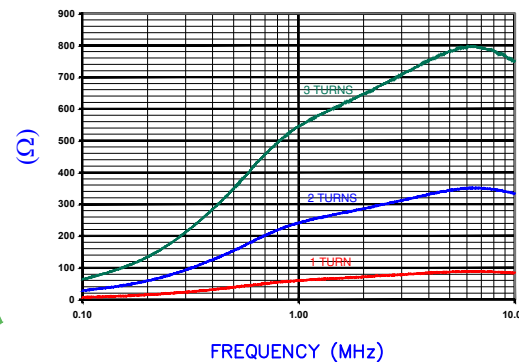

AGILENT E4991A RF Impedance/Material Analyzer  
 HP 16092A Test Fixture REF #2606

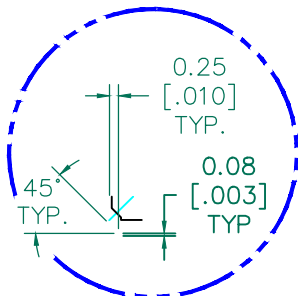

DETAIL "A"  
 CHAMFER  
 SCALE=5:1



FERRITE CORE DIMENSIONS (SPEC):

A	9.50 [.374]	±	0.25 [.010]
B	5.10 [.201]	±	0.25 [.010]
C	19.05 [.750]	±	0.38 [.015]

WEIGHT/1000 4.73 kgs [10.43 Lbs]

DIMENSIONS ARE IN mm [INCHES].				This print is the property of Laird Tech. and is loaned in confidence subject to return upon request and with the understanding that no copies shall be made without the written consent of Laird Tech. All rights to design or invention are reserved.		<b>Laird</b>	
D	UPDATE COMPANY LOGO	07/22/15	TMB	PROJECT/PART NUMBER:	LFB095051-000	REV	D
C	REMOVE MIN SPEC @ 500 KHz	02/10/06	TMB	PART TYPE:	FERRITE CORE	DRAWN BY:	TMB
B	UPDATE TOLS. ON DIMENSIONS A,B&C ADD TEST REF TO CURVE	12/22/04	JRK	DATE:	09/23/02	SCALE:	5:1
A	ORIGINAL DRAFT	09/23/02	TMB	MATERIAL:	LF	TOOL #	B0375
REV	DESCRIPTION	DATE	INT	CAD #	LFB090050-000-D		