



Chipsmall Limited consists of a professional team with an average of over 10 year of expertise in the distribution of electronic components. Based in Hongkong, we have already established firm and mutual-benefit business relationships with customers from,Europe,America and south Asia,supplying obsolete and hard-to-find components to meet their specific needs.

With the principle of "Quality Parts,Customers Priority,Honest Operation,and Considerate Service",our business mainly focus on the distribution of electronic components. Line cards we deal with include Microchip,ALPS,ROHM,Xilinx,Pulse,ON,Everlight and Freescale. Main products comprise IC,Modules,Potentiometer,IC Socket,Relay,Connector.Our parts cover such applications as commercial,industrial, and automotives areas.

We are looking forward to setting up business relationship with you and hope to provide you with the best service and solution. Let us make a better world for our industry!



Contact us

Tel: +86-755-8981 8866 Fax: +86-755-8427 6832

Email & Skype: info@chipsmall.com Web: www.chipsmall.com

Address: A1208, Overseas Decoration Building, #122 Zhenhua RD., Futian, Shenzhen, China





HDMI Mezzanine Card – Revision B

User's Guide

Introduction

LatticeECP3 Video Protocol Board includes a daughter card connection to support applications that can be implemented using SERDES. This daughter card connection includes three connectors for the signals of a whole SERDES quad, the control/status signals and the power/ground pins.

The HDMI Mezzanine Card is a LatticeECP3 Video Protocol Board daughter card designed for demonstrating the Lattice HDMI/DVI solution using LatticeECP3 SERDES. The scope of this user's guide covers only revision B of the HDMI Mezzanine Card. Please refer to EB52, [LatticeECP3 Video Protocol Board Revision C User's Guide](#) for more information about the LatticeECP3 device connection to the daughter card.

As shown in Figure 1, this card uses Single-Link 19-pin HDMI Type-A connectors. If using passive HDMI-to-DVI cables, this card can also be used to support DVI video.

Figure 1. HDMI Mezzanine Card

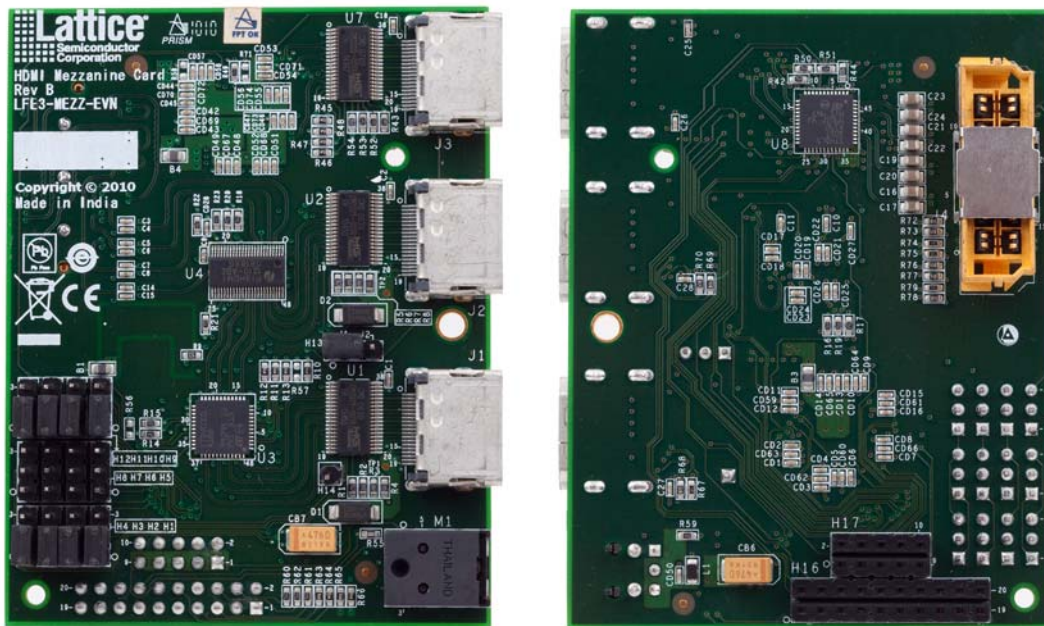

Features

- Supports two different HDMI/DVI input paths, with or without the cable equalizer
- Supports HDMI/DVI output with TMDS level shifter
- TOSLINK fiber optic receiving module for S/PDIF audio input
- Headers for HPD, CEC controls and the EDID signals
- ESD protection devices for both HDMI/DVI inputs and HDMI/DVI outputs

Functional Description

There are four transmit channels and four receive channels in each of the LatticeECP3 SERDES quads. For implementing a Single Link HDMI or DVI interface, which includes three data channels and one clock channel, all four transmit channels and three receive channels are used. The clock channel on the receive side is connected to the dedicated SERDES differential reference clock pins. Since the common mode voltage of the HDMI/DVI TMDS sig-

nals is different from the SERDES CML signals, and the TMDS coding scheme maintains the DC balance of the signal, the AC coupling capacitors are used to block the DC component of the driving signal.

Figure 2 shows the functional block diagram of the HDMI Mezzanine Card. For validation purposes, this card is designed to include two HDMI/DVI input ports. One of these input paths has a TMDS cable equalizer and the other does not. The signals of both paths will go into the 2-to-1 TMDS MUX, then the AC coupling capacitors to the SERDES input pins. Depending on which pins a shunt is installed on a 3-pin header, one of the two inputs will be selected and the signals will be fed to the SERDES.

For meeting the HDMI/DVI’s strict electrical compliance test specification, a TMDS level shifter is added to the output path. This level shifter can be removed if the design does not have this requirement. The ESD protector is added on both the input and output HDMI/DVI ports. Other than the HDMI/DVI, an S/PDIF input interface is also included for bringing in a digital audio stream through the TOSLINK connector.

Figure 2. Functional Block Diagram

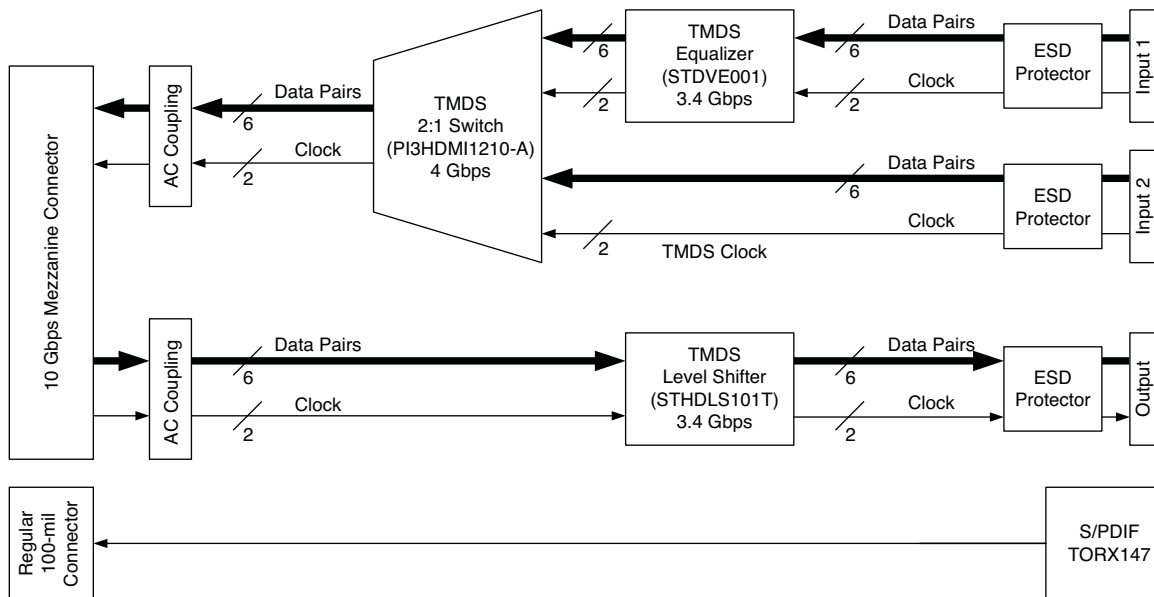

Figure 3 shows the HDMI Mezzanine Card installed on the LatticeECP3 Video Protocol Board. The two cables are the HDMI cables connecting to J1 (HDMI/DVI input) and J3 (HDMI/DVI output) of the daughter card. A 12 mm tall standoff is recommended for securing the HDMI Mezzanine Card on the LatticeECP3 Video Protocol Board through screws.

Figure 3. HDMI Mezzanine Card Installed on the LatticeECP3 Video Protocol Board



Header Settings

This section describes the header settings on the HDMI Mezzanine Card. However, since the card uses SERDES quad C when plugging into the LatticeECP3 Video Protocol Board, the VCCOB and the VCCIB of SERDES quad C need to be powered properly. Please make sure shuts are installed on J18 and J22 of the LatticeECP3 Video Protocol Board.

As mentioned previously, the selection of the two HDMI/DVI inputs is done by a 3-pin header. Table 1 shows the locations of where the shunt should be installed.

Table 1. MUX Selection Control

HDMI/DVI Input	Mode	MUX Select	Shunt Installation on H13
J1	Equalized HDMI/DVI Input	High	Pin 1/Pin 2
J2	Non-Equalized HDMI/DVI Input	Low	Pin 2/Pin 3

Other than the TMDS clock and data pairs, the HDMI/DVI interface includes CEC, HPD and the DDC clock and data signals. By installing shuts on different locations of the 12 headers, these signals can be selected to be bypassed from the HDMI/DVI input to the HDMI/DVI output, or they can be selected to be connected to the LatticeECP3 FPGA on the LatticeECP3 Video Protocol Board.

Figure 4 shows the locations of these 12 headers on the HDMI Mezzanine Card and the signals these headers control. The 12 headers are divided into four groups as shown in Figure 4. Each group includes three headers for controlling one of the four signals. The black square is used to indicate pin 1 of each header.

Figure 4. Headers for CEC, HDP, S Settings, LatticeECP3 Video Protocol Board

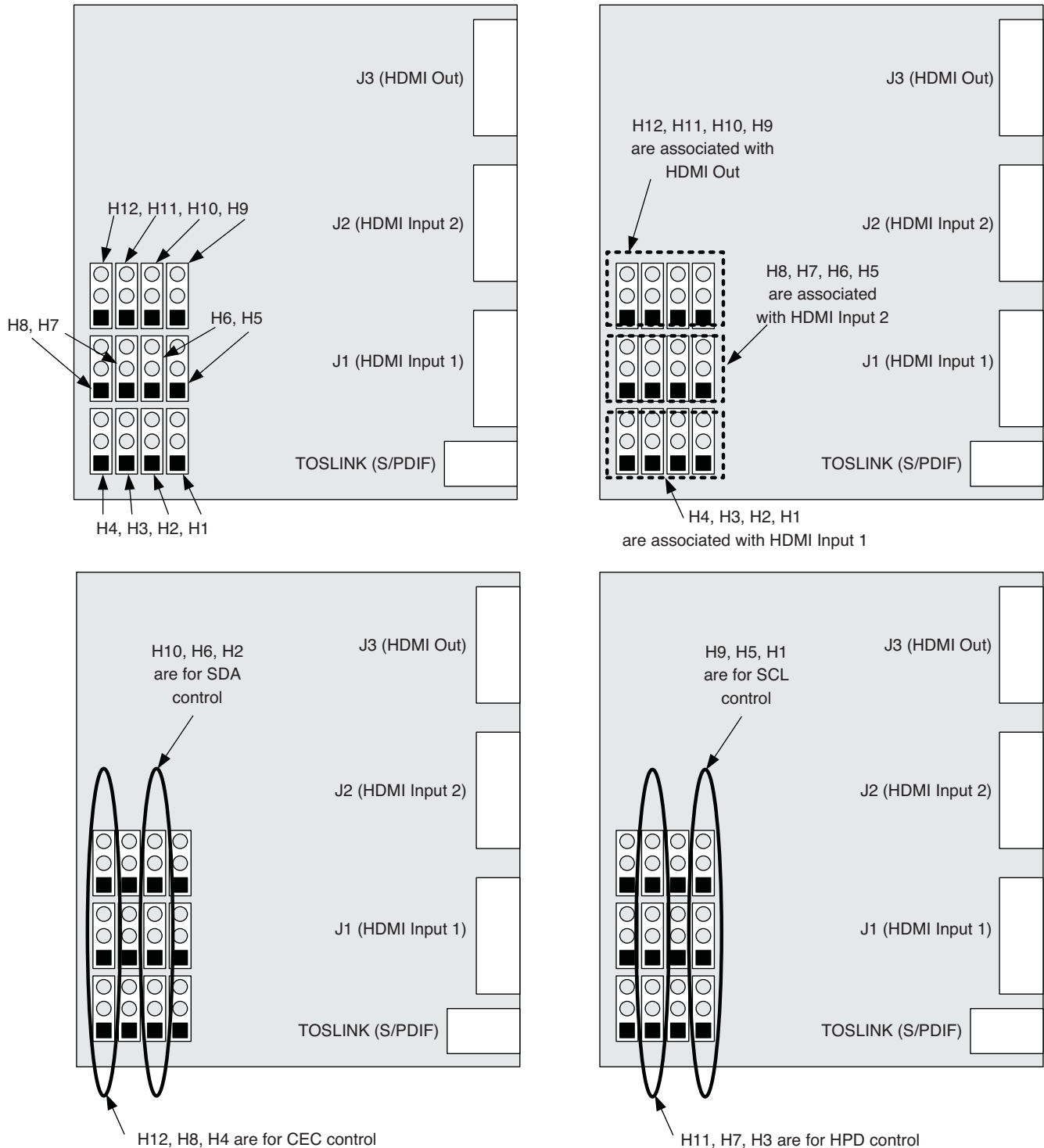

Figure 5 is a conceptual connection of the header connections. This applies to all four signals. An example of the connection is shown in Figure 6. In this example, the shunts are installed on pin1/pin 2 of H9 ~ H12 and pin2/pin3 of H1 ~ H4. This will bypass the four signals between J1 and J3.

Figure 5. Conceptual Connection for Headers H1 to H12

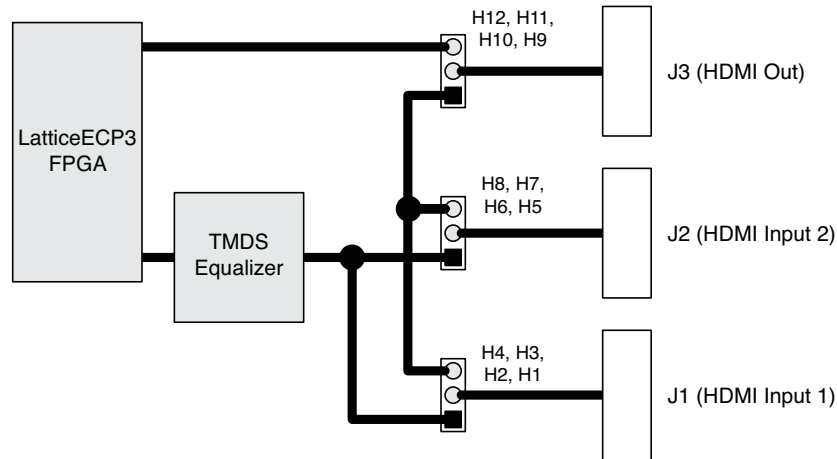
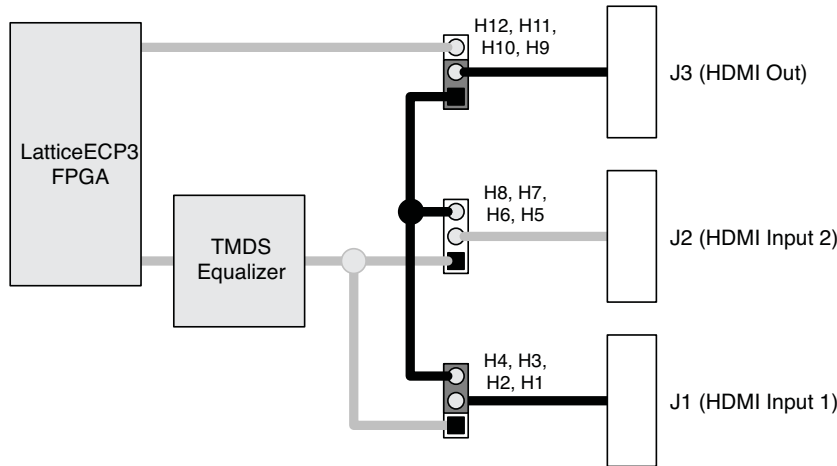

Figure 6. Example for Bypassing CEC, HPD, SDA, SCL Between J1 and J3



Technical Support Assistance

Hotline: 1-800-LATTICE (North America)
+1-503-268-8001 (Outside North America)
e-mail: techsupport@latticesemi.com
Internet: www.latticesemi.com

Revision History

Date	Version	Change Summary
September 2010	01.0	Initial release.
September 2012	01.1	Added Appendix B. Hardware Variants. Updated document with new corporate logo.

© 2012 Lattice Semiconductor Corp. All Lattice trademarks, registered trademarks, patents, and disclaimers are as listed at www.latticesemi.com/legal. All other brand or product names are trademarks or registered trademarks of their respective holders. The specifications and information herein are subject to change without notice.

Appendix A. Schematic

Figure 7. Cover Page

COVER PAGE

HDMI MEZZANINE CARD - LATTICE SEMICONDUCTOR CORPORATION

Page	Description
1	Cover Page
2	Revision History
3	Block Diagram
4	Power Scheme
5	HDMI Input Ports
6	I2C, HPD, CEC Selection
7	HDMI Equalizer
8	TMDS Switch
9	HDMI Output Port
10	B To B Connectors and Audio Input
11	Board Accessories

Internal Version 0.02	
	GDA Technologies Ltd, L & T Infotech Park, Mount Poonamallee Road, Manapakkam, Ch 89
	Tel: 91-44-2253 7900 Fax: 91-44-2252 3514 www.gdatech.com
Title COVER PAGE	
Size B	Document Number GDA09CB004B
Date Tuesday, March 02, 2010	Rev B
Sheet 1 of 11	

Figure 8. Revision History

REVISION HISTORY			
Revision	Verison	Release Date	Description
A	0.01	18-May-2009	Initial release
	0.02	20-May-2009	Jumper options for DDC, HPD and CEC lines modified
	0.03	27-May-2009	HDMI signals swapping done for layout feasibility
	0.04	29-May-2009	Single Ended signals swapping done at control signal connector for layout feasibility
	0.05	02-Jun-2009	Pin Mapping table added for Mezzanine and control signal connectors
	0.06	03-Jun-2009	Pin mapping table modified. Pullups added for output signals from ECP3 board. SPDIF data assigned to MZ_CTRL13
	0.07	09-Jun-2009	Customer Feedbacks implemented
	0.08	10-Jun-2009	Customer Feedbacks implemented
	0.09	11-Jun-2009	Version change after customer modification of schematics for HDMI Equalizer
	0.10	15-Jun-2009	Customer Feedbacks implemented
	0.11	17-Jun-2009	Customer Feedbacks implemented
	0.12	24-Jun-2009	Customer Feedbacks implemented on decoupling caps for U3, U8
B	0.01	11-Feb-2010	Clock cleaner is removed and eight 50ohms pullup resistors are added for the HDMI output port as per customer requirement
	0.02	2-Mar-2010	'GDA confidential' is removed from all pages as per customer feedback

Internal Version 0.02			
	GDA Technologies Ltd, L & T Infotech Park, Mount Poonamallee Road, Manapakkam, Ch 89		Tel: 91-44-2253 7900 Fax: 91-44-2252 3514 www.gdatech.com
	Title REVISION HISTORY		
Size B	Document Number	GDA09CB004B	Rev B
Date:	Tuesday, March 02, 2010	Sheet	2 of 11

Figure 9. Block Diagram

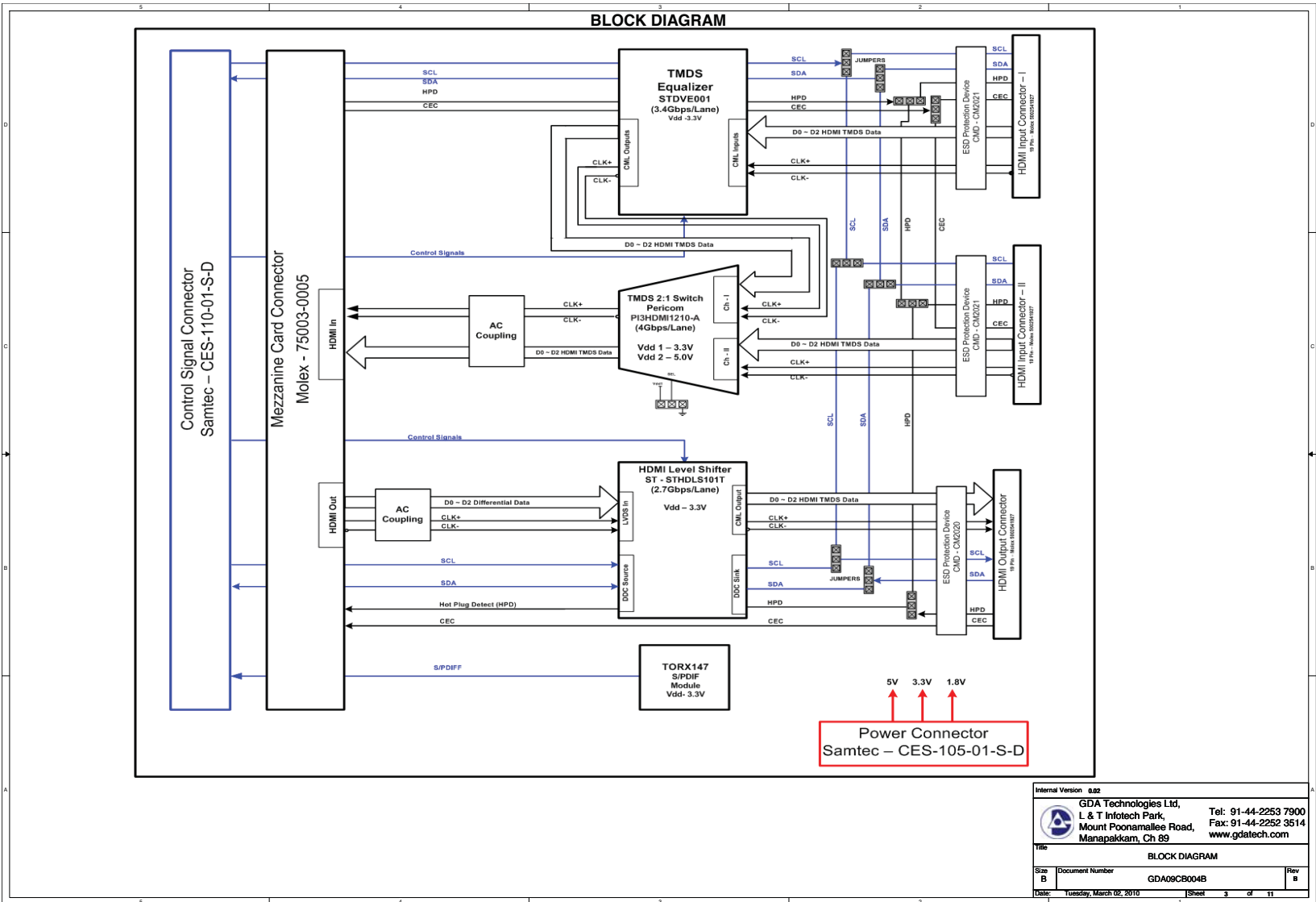

Figure 10. Power Scheme

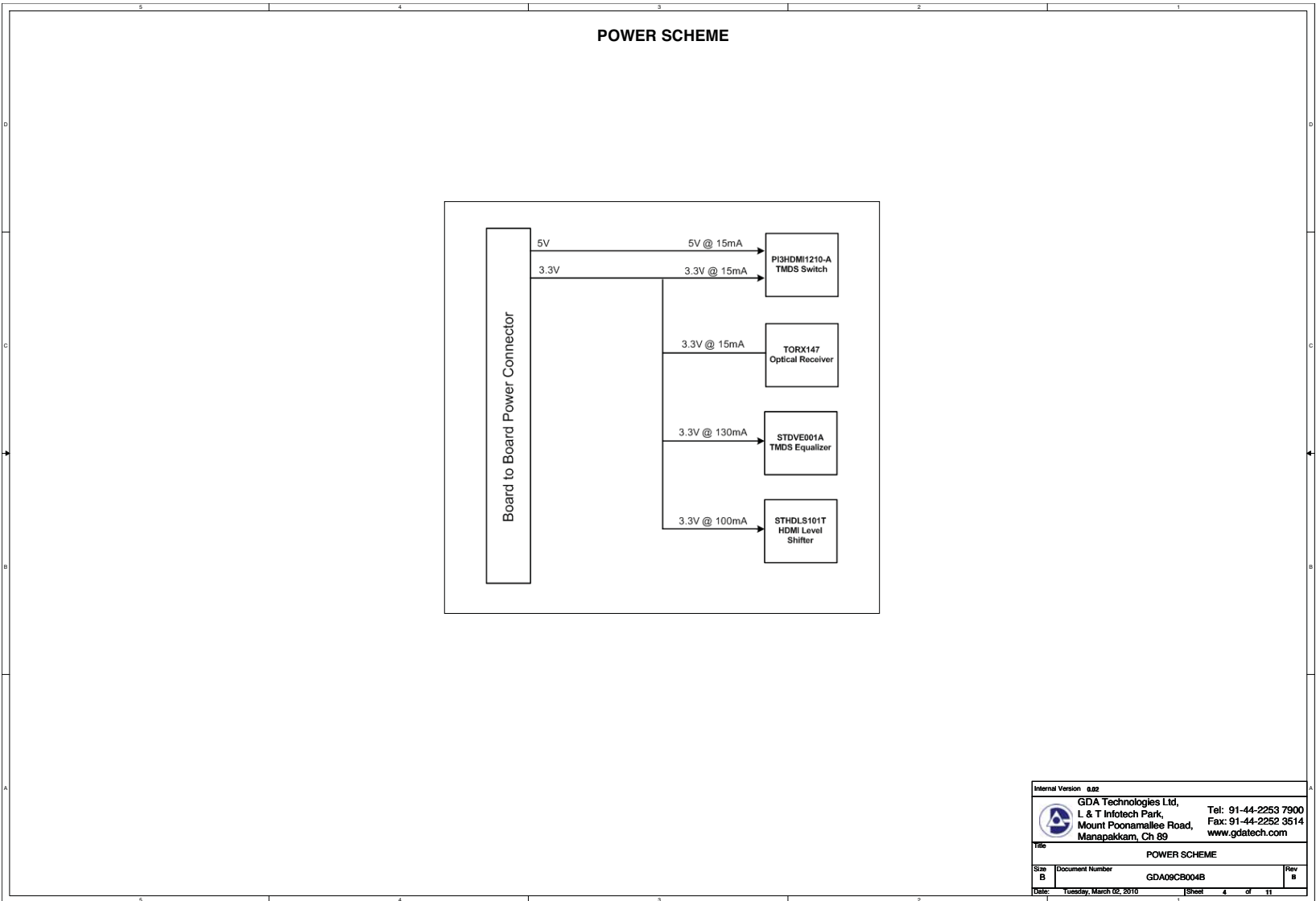

Figure 11. HDMI Input Ports

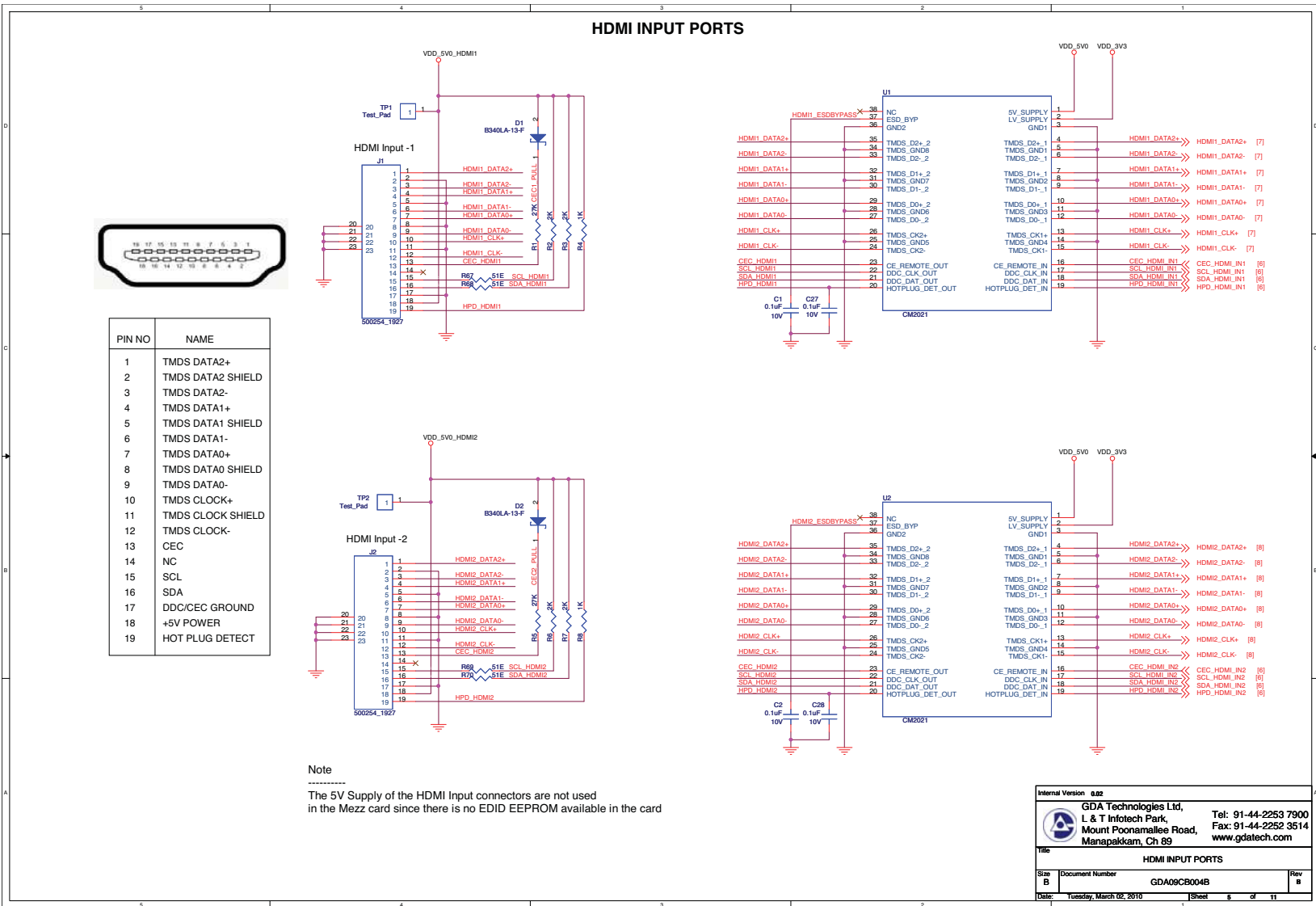
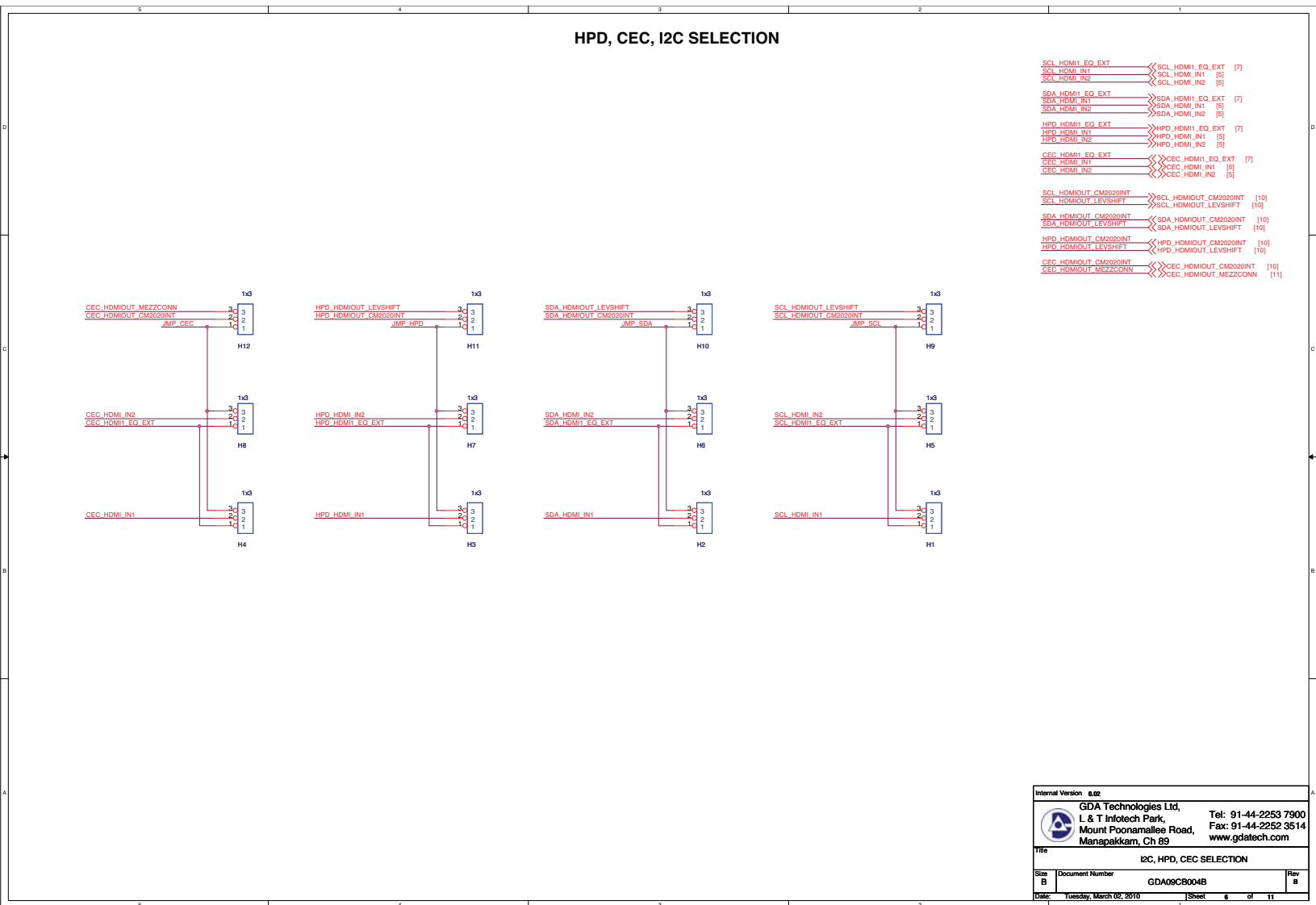

Figure 12. I2C, HPD, CEC Selection



Internal Version 6.02		
	GDA Technologies Ltd, L & T Infotech Park, Mount Poonamallee Road, Manapakkam, Ch 89	Tel: 91-44-2253 7900 Fax: 91-44-2252 3514 www.gdatech.com
	I2C, HPD, CEC SELECTION	
Size B	Document Number GDA09CB004B	Rev B
Date: Tuesday, March 02, 2010	Sheet 6 of 11	

Figure 13. HDMI Equalizer

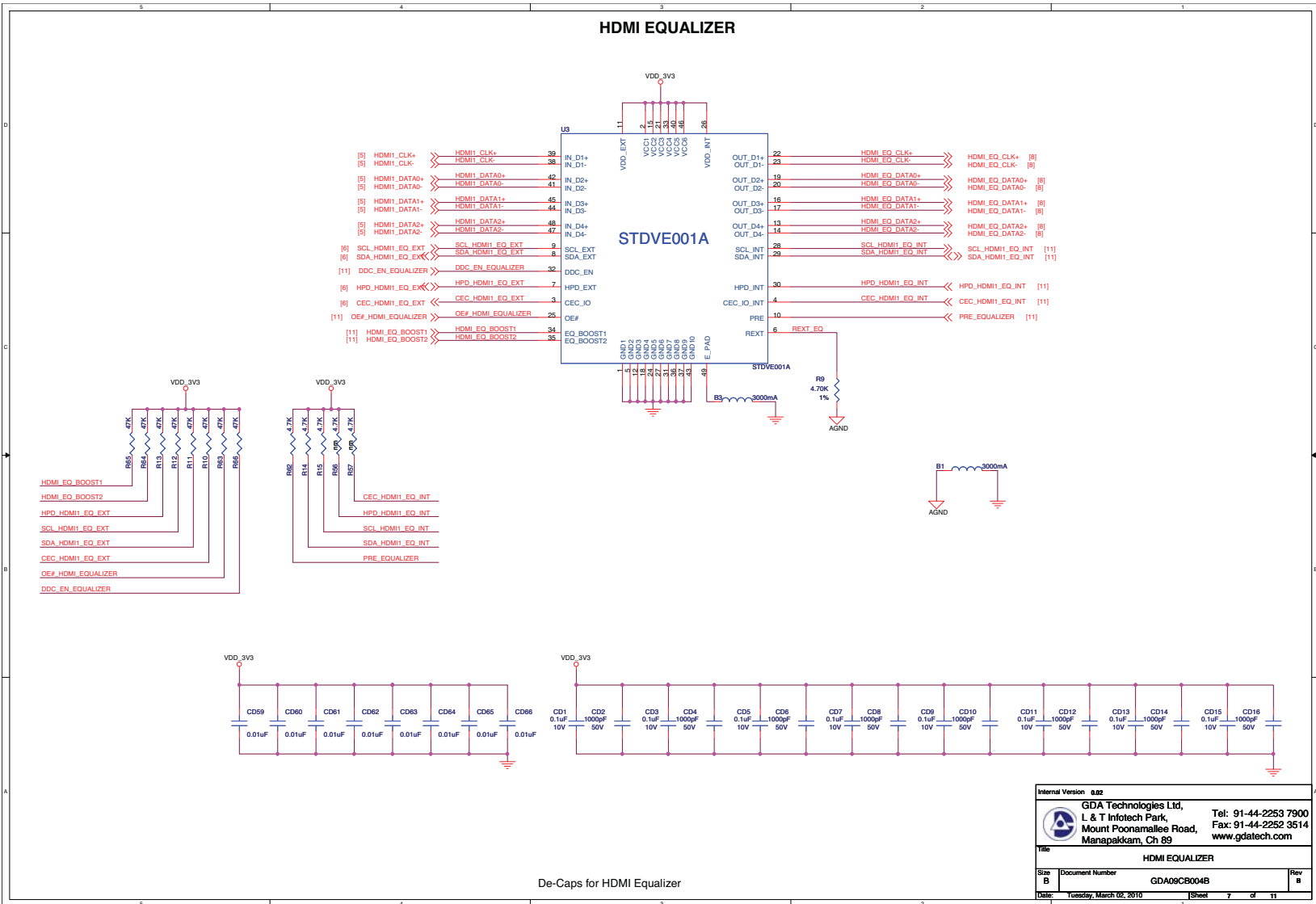

Figure 14. TMDS Switch

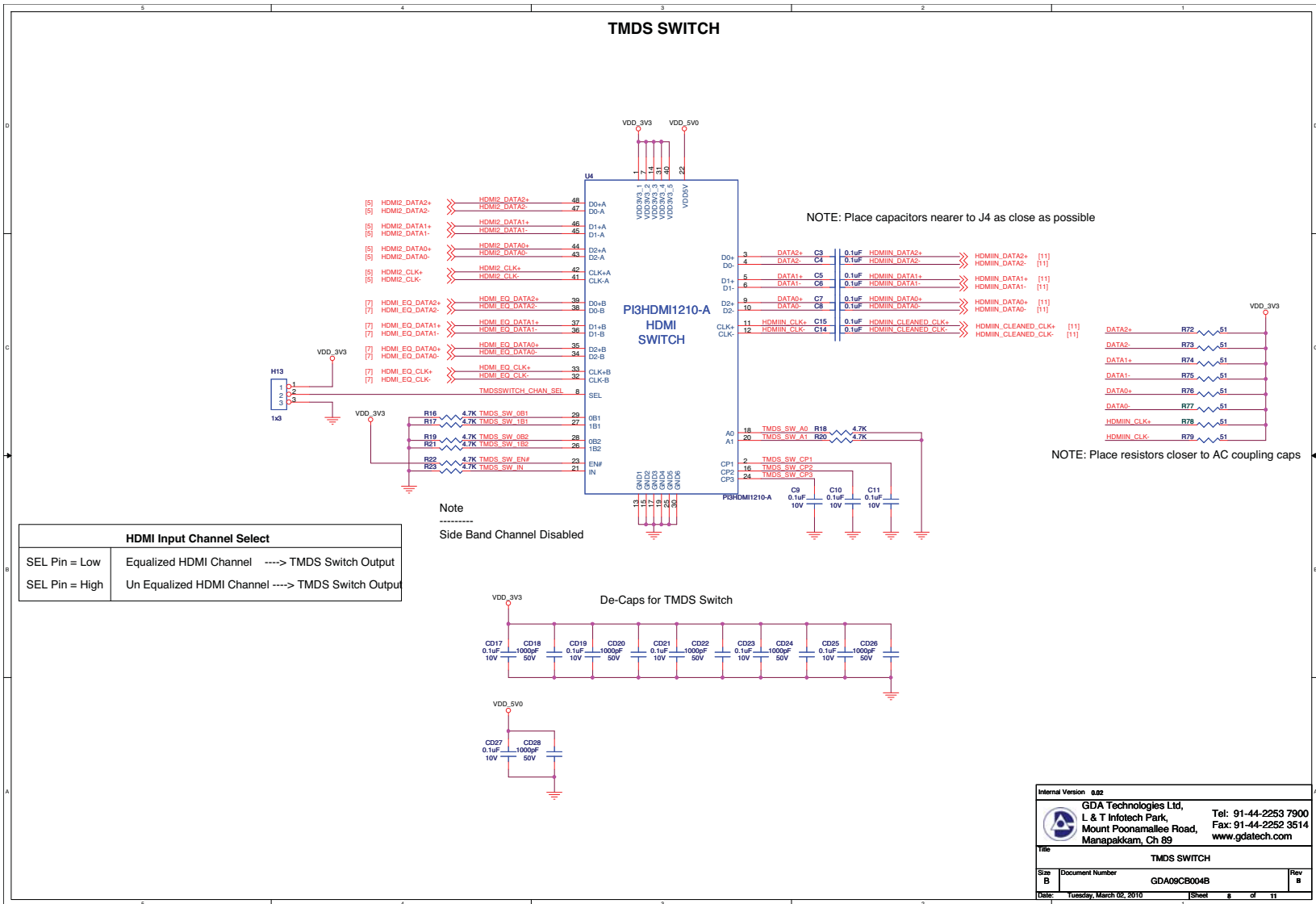

Figure 15. HDMI Output Port

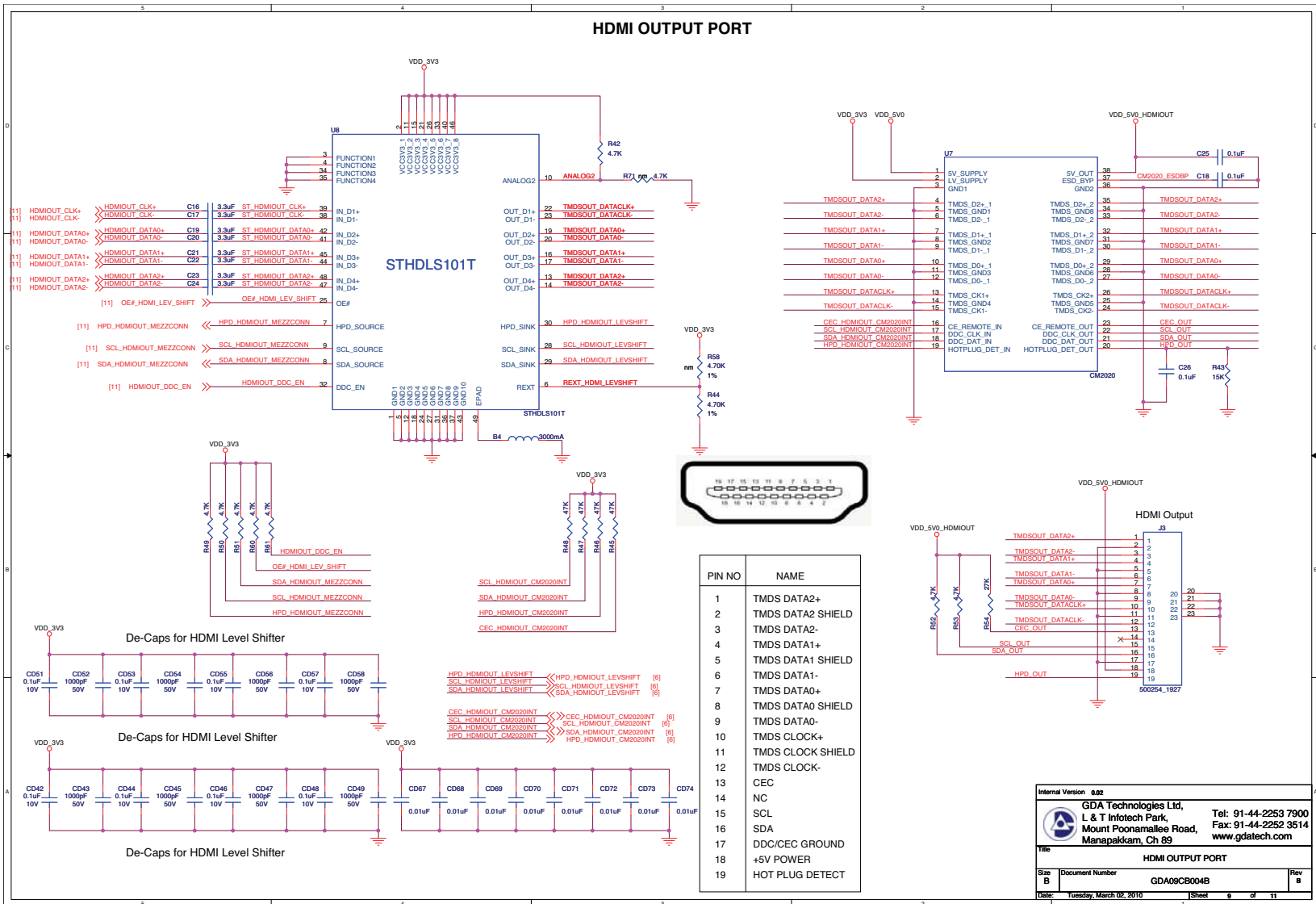

Figure 16. B to B Connectors and Audio In

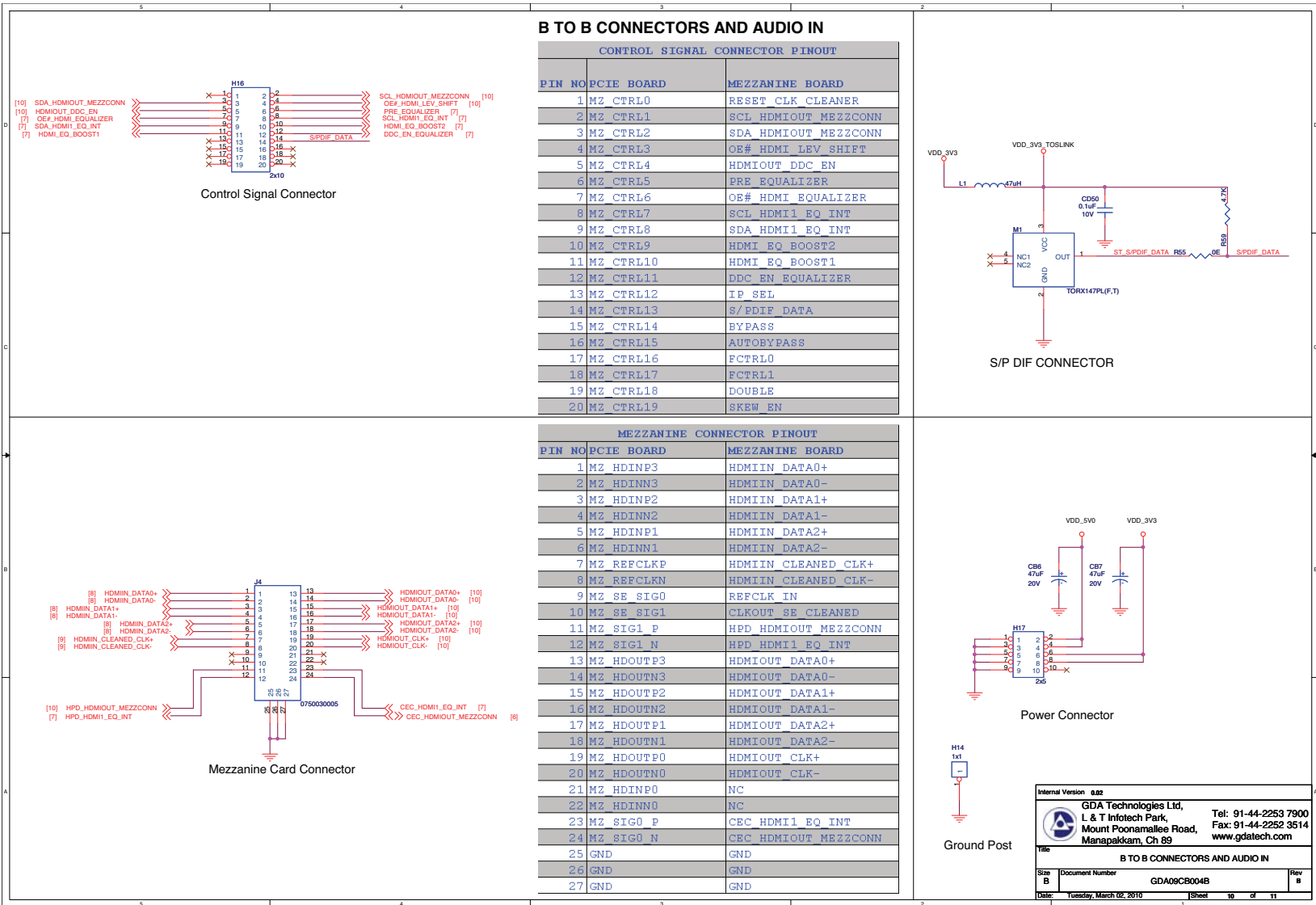
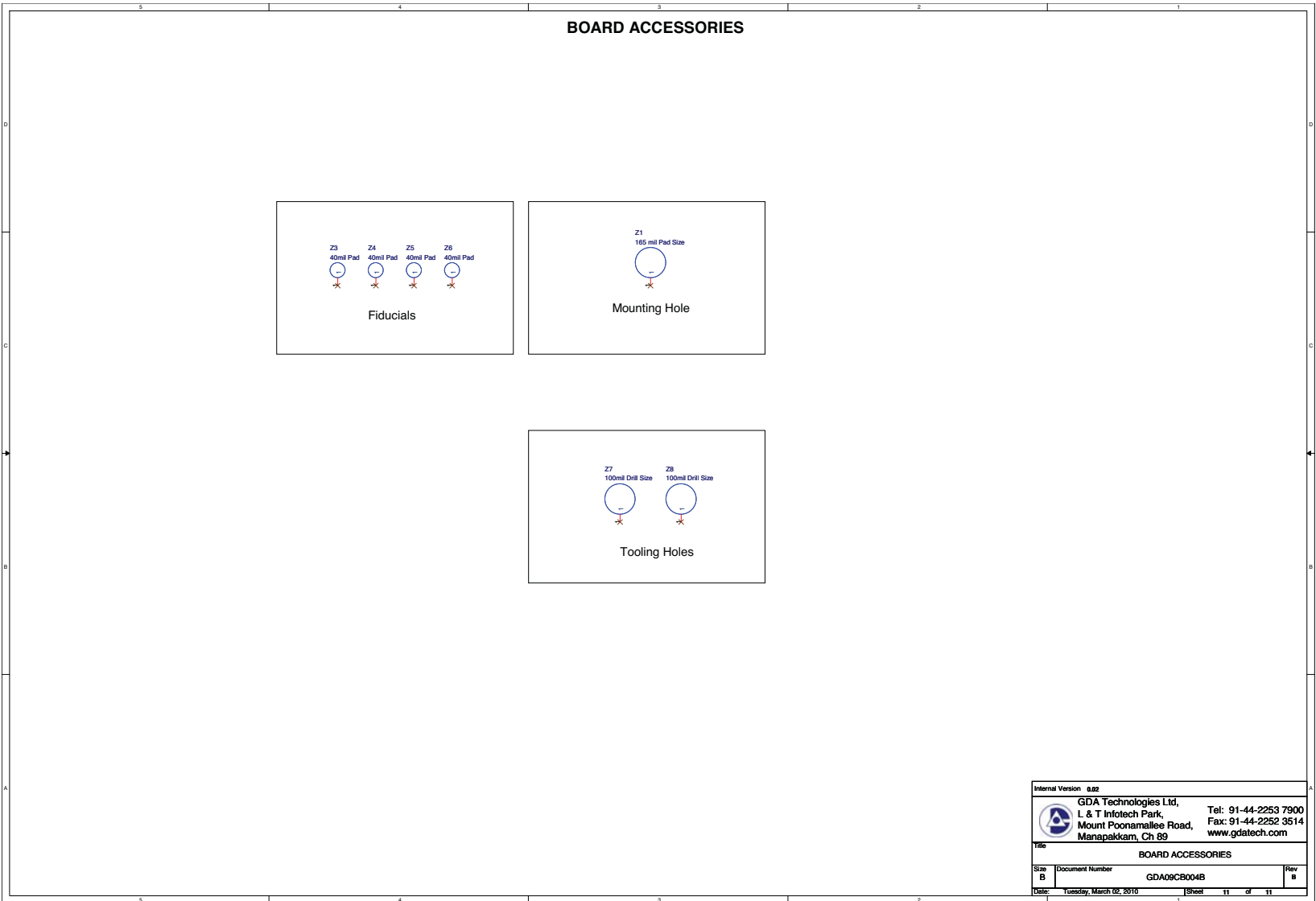

Figure 17. Board Accessories



Appendix B. Hardware Variants

Early versions of the HDMI Mezzanine Card Revision B were produced with U3 (STMicroelectronics STDVE001A Adaptive single 3.4 Gbps TMDS/HDMI signal equalizer) populated. On the current version of the HDMI Mezzanine Card Revision B, U3 is not populated.

To receive HDMI/DVI input when U3 is unpopulated:

- Connect the HDMI/DVI source using J2.
- Install a shunt between pin 2 and pin 3 of header H13 to route J2 HDMI/DVI signals to the FPGA via the Mezzanine connector.

On the current version of the board, the following additional changes were made:

- To support the Extended Display Identification Data (EDID) via the I²C interface of the FPGA, two modification wires are installed in the following locations on the new HDMI Mezzanine Card Revision B:
 - R15 (pad nearest U3) to R12 (pad nearest U3)
 - R14 (pad nearest U3) to R11 (pad nearest U3)These wires bridge the I²C bus around vacant U3.
- The resistors R2, R3, R6 and R7 are not populated (to reduce I²C bus pull-up strength).
- The resistors R71 and R58 are not populated (to correct a pull-down contention).