



Chipsmall Limited consists of a professional team with an average of over 10 year of expertise in the distribution of electronic components. Based in Hongkong, we have already established firm and mutual-benefit business relationships with customers from,Europe,America and south Asia,supplying obsolete and hard-to-find components to meet their specific needs.

With the principle of "Quality Parts,Customers Priority,Honest Operation,and Considerate Service",our business mainly focus on the distribution of electronic components. Line cards we deal with include Microchip,ALPS,ROHM,Xilinx,Pulse,ON,Everlight and Freescale. Main products comprise IC,Modules,Potentiometer,IC Socket,Relay,Connector.Our parts cover such applications as commercial,industrial, and automotives areas.

We are looking forward to setting up business relationship with you and hope to provide you with the best service and solution. Let us make a better world for our industry!



Contact us

Tel: +86-755-8981 8866 Fax: +86-755-8427 6832

Email & Skype: info@chipsmall.com Web: www.chipsmall.com

Address: A1208, Overseas Decoration Building, #122 Zhenhua RD., Futian, Shenzhen, China



Description

- Industry standard SMD package with 5.5mm lead spacing
Suitable for real time clock applications
Plastic encapsulated
- Model: 85SMX
- Model Issue number: 9

Frequency Parameters

- Frequency: 32.7680kHz
- Frequency Tolerance: $\pm 20.00\text{ppm}$
- Overtone Order: Fundamental
- Ageing: $\pm 5\text{ppm max per year @ } 25^\circ\text{C}$

Electrical Parameters

- Load Capacitance (CL): 12.50pF
- Shunt Capacitance (C0): 1pF typ
- Drive Level: 1.0 $\mu\text{W max}$
- ESR: 50.00k Ω max

Environmental Parameters

- Storage Temperature Range: -55 to 125°C
- Drop: 75cm drop (3 times) onto hard wooden board
- Vibration: 1.5mm amplitude, 10Hz-60Hz, 2-3mins in 3 mutually perpendicular planes, duration 2hrs each plane

Manufacturing Details

- Not suitable for use with ultrasonic cleaning techniques

Compliance

- RoHS Status (2011/65/EU): Compliant
- REACH Status: Compliant
- MSL Rating (JDEC-STD-033): Not Applicable

Packaging Details

- Pack Style: Bulk Loose in bulk pack
Pack Size: 100
- Alternative packing option available



Outline (mm)

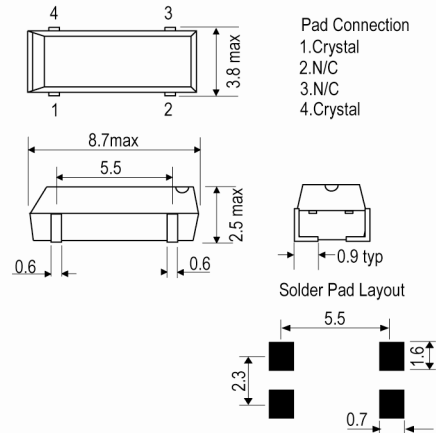

Typical Frequency Stability Characteristics

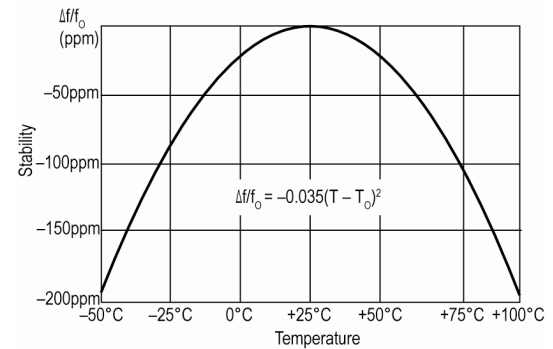

Sales Office Contact Details:

UK: +44 (0)1460 270200
Germany: 0800 1808 443

France: 0800 901 383
USA: +1.760.318.2824

Email: info@iqdfrequencyproducts.com
Web: www.iqdfrequencyproducts.com