



Chipsmall Limited consists of a professional team with an average of over 10 year of expertise in the distribution of electronic components. Based in Hongkong, we have already established firm and mutual-benefit business relationships with customers from,Europe,America and south Asia,supplying obsolete and hard-to-find components to meet their specific needs.

With the principle of “Quality Parts,Customers Priority,Honest Operation,and Considerate Service”,our business mainly focus on the distribution of electronic components. Line cards we deal with include Microchip,ALPS,ROHM,Xilinx,Pulse,ON,Everlight and Freescale. Main products comprise IC,Modules,Potentiometer,IC Socket,Relay,Connector.Our parts cover such applications as commercial,industrial, and automotives areas.

We are looking forward to setting up business relationship with you and hope to provide you with the best service and solution. Let us make a better world for our industry!



Contact us

Tel: +86-755-8981 8866 Fax: +86-755-8427 6832

Email & Skype: info@chipsmall.com Web: www.chipsmall.com

Address: A1208, Overseas Decoration Building, #122 Zhenhua RD., Futian, Shenzhen, China



- **900 MHz FHSS DNT90/GPRS Cellular Gateway**
- **Optional 128-Bit AES Encryption**
- **Point-to-point, Point-to-multipoint or Store and Forward Operation**
- **158 mW EIRP 900 MHz Transmitter Power**
- **3G EVDO Cellular Modem**
- **HTTP Posts, SimpleDB, XML and ModBus/TCP Support**

The LG90C is the Murata M2M family's EV-DO Cellular Gateway for DNT90 900 MHz Frequency Hopping Spread Spectrum (FHSS) based products, including the SN90xx series sensor modems and the ZN-90M RS-485 serial modems. On the 900 MHz side, the LG90C's DNT90 radio provides robust wireless communications. On the cellular side, the LG24C utilizes a dual-band EV-DO modem. In between is the intelligence to allow seamless integration of 900 MHz DNT90 based devices into network or Internet cloud based applications. TCP/IP Internet protocol support reduces the effort to tie LG90C networks into existing sensing and monitoring applications. The LG90C gateway shares the same API as the other RFM2M gateway products, letting you pick the wireless technology that best suits your requirements with only a minimum of changes to your application.

LG90C

DNT90/EV-DO Cellular Gateway



Absolute Maximum Ratings

Rating	Value	Units
Power Supply Input Voltage Range	-5 to +30	V
Non-operating Ambient Temperature Range	-40 to +85	°C

Electrical and Mechanical Specifications

Specification	Sym	Notes	Minimum	Typical	Maximum	Units
900 MHz Operating Frequency Range			902.76		927.24	MHz
Spread Spectrum Modulation			Frequency Hopping (FHSS)			
Modulation Type			FSK			
Number of RF Channels			25, 26 or 52			
RF Data Transmission Rate				100		kbps
Receiver Sensitivity				-100		dBm
Transmitter EIRP Output Power Options with Supplied 2 dBi Antenna			40 or 158			mW
Optimum Antenna Impedance				50		Ω
Antenna Connector			Reverse SMA Male			
Access Scheme			Ad Hoc TDMA			
Network Topologies			Point-to-Point, Point-to-Multipoint, Store & Forward			
Network Integrity			Heartbeat Transmissions			
Encryption			128-bit AES			

Electrical and Mechanical Specifications (continued)

Specification	Sym	Notes	Minimum	Typical	Maximum	Units
Cellular Modem			EV-DO			
Frequency Bands			800/1900			MHz
RJ-45 Ethernet Port			10/100Base-T, Auto-sensing			
Ethernet Protocol			TCP/IP, UDP, ARP, ICMP, DHCP			
Internet Protocol			ModBus/TCP, HTTP Posts, SimplexDB, XML			
USB Diagnostic Console Port			USB 2.0			
Power Supply Input Voltage Range	V _{CC}		+9		+30	VDC
Current Consumption					1.5	A
AC Power Supply			110/220 VAC Wall-plug Adaptor with International Plug Set			
Case Dimensions			7.30 x 4.67 x 1.5 inches (185.4 x 118.6 x 38.1 mm)			
Mounting			Left and Right Flanges, Two Pre-drilled Holes in Each Flange			
Operating Temperature Range			-40		+85	°C
Operating Relative Humidity Range		1	5		95	%

Notes:

1. Non-condensing humidity environment.

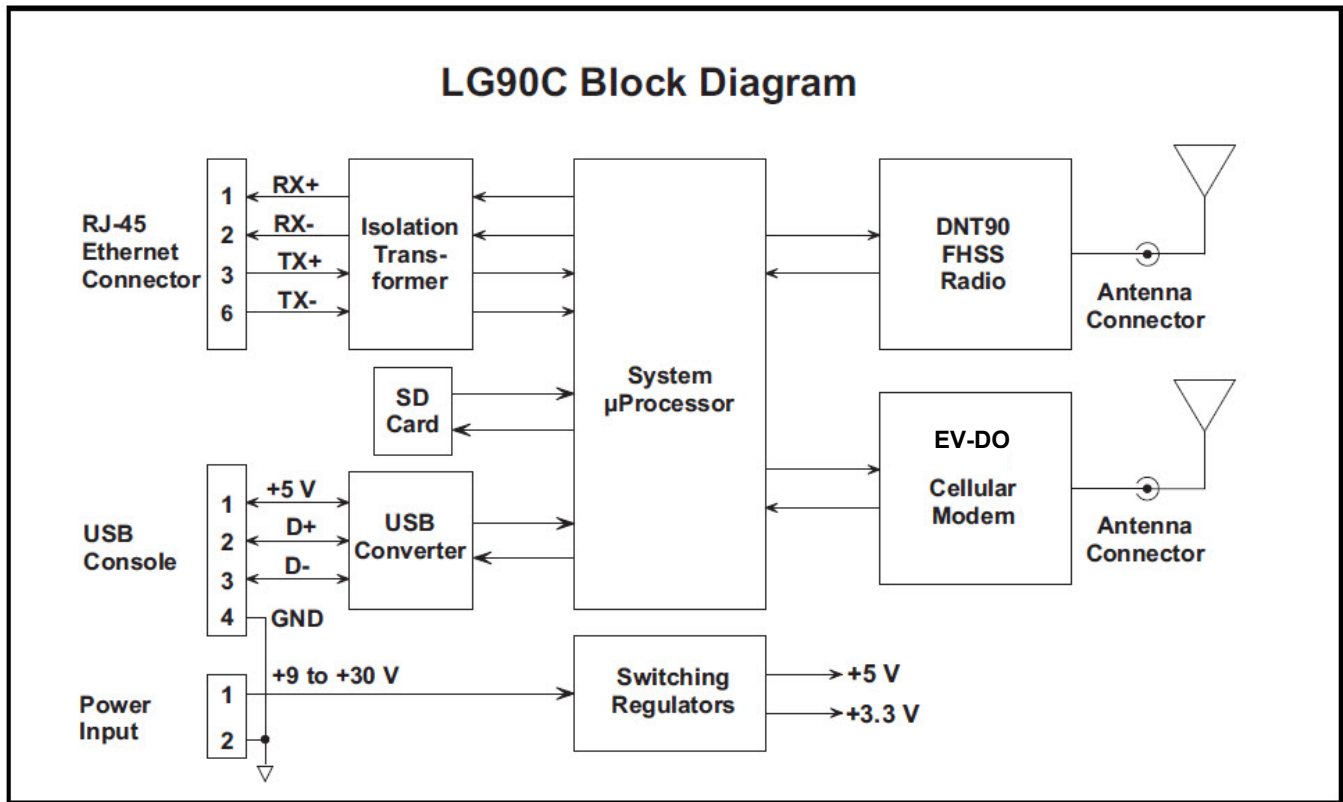

Figure 1

LG90C Operation

The LG90C is a robust GPRS cellular gateway for RFM’s DNT90 Frequency Hopping Spread Spectrum (FHSS) radios. The LG90C’s DNT90 radio operates in the 902 to 928 MHz ISM band, transmitting data at 100 kbps with a power output of 40 or 158 mW EIRP. The GPRS cellular modem provides gateway connectivity in the 800, 900, 1800 and 1900 MHz GSM bands.

The unit is packaged in a rugged aluminum enclosure, and ships with a universal wall-plug power supply a 2 dBi 900 MHz dipole antenna, and a four-band GSM dipole antenna. The LG90C is also compatible with RFM’s complete line of 900 MHz antennas, allowing extended operating range where allowed by local regulations.

The switching regulators used in the LG90C support a wide input voltage range, from +9 to +30 Vdc for operation from battery-backed DC power sources.

LG90C gateways support point-to-point or point-to-multipoint networks, with store & forward range extension capabilities for large site operations.

The dual-band EV-DO cellular modem provides 3G connectivity through virtually any GSM network, providing seamless integration of DNT90 based remote devices, such as the SN90R420, into network or Internet cloud based applications.

The LG90C includes support for TCP/IP, UDP, ARP, ICMP and DHCP Ethernet protocols, plus ModBus/TCP, HTTP Posts, SimpleDB and XML Internet protocols. This wide array of protocol support greatly reduces the effort to tie LG90C networks into existing sensing and monitoring applications.

ModBus/TCP support allows the LG90C gateway to seamlessly deliver wirelessly collected sensor readings using the ModBus/TCP standard protocol. The LG90C in conjunction with DNT90-based nodes provide a robust wireless data collection network suitable for a wide range of ModBus automation applications.

The LG90C is configured through an Ethernet port using a built-in configuration utility formatted as a web page.

RJ-45 Ethernet Connector

Pin	Name	I/O	Description
1	TX+	O	This pin is the Ethernet positive differential output.
2	TX-	O	This pin is the Ethernet negative differential output.
3	RX+	I	This pin is the Ethernet positive differential input.
4	RESERVED	-	This pin is reserved for future use and should not be connected.
5	RESERVED	-	This pin is reserved for future use and should not be connected.
6	RX-	I	This pin is the Ethernet negative differential input.
7	RESERVED	-	This pin is reserved for future use and should not be connected.
8	RESERVED	-	This pin is reserved for future use and should not be connected.

USB Console Port Connector

Pin	Name	I/O	Description
1	+5 V	I	This pin is the +5 V USB Input
2	D+	I/O	This pin is the positive differential I/O port.
3	D-	I/O	This pin is the negative differential I/O port.
4	GND	GND	LG90C ground.

DC Power Terminal Block

Pin	Name	I/O	Description
1	+PWR	I	Positive power supply input, +9 to +30 V.
2	GND	-	LG90C ground.

LED Indicators

Pin	Name	I/O	Description
1	ACTIVITY	O	Left-most LED on the front of the unit, amber color. Indicates RF communications activity.
2	LINK	O	Middle LED on the front of the unit, red color. On the base, this LED indicates one or more remotes are linked to it. On a remote, this LED indicates it is linked to the base.
3	POWER	O	Right-most LED on the front of the unit, green color. Indicates the unit is powered up.
4	ETH ACT	O	Upper-left LED on the RJ-45 Ethernet connector, green color. Indicates the Ethernet port is linked.
5	ETH LINK	O	Upper-right LED on the RJ-45 Ethernet connector, amber color. Indicates the Ethernet port communications activity.

LG90C Outline Drawing

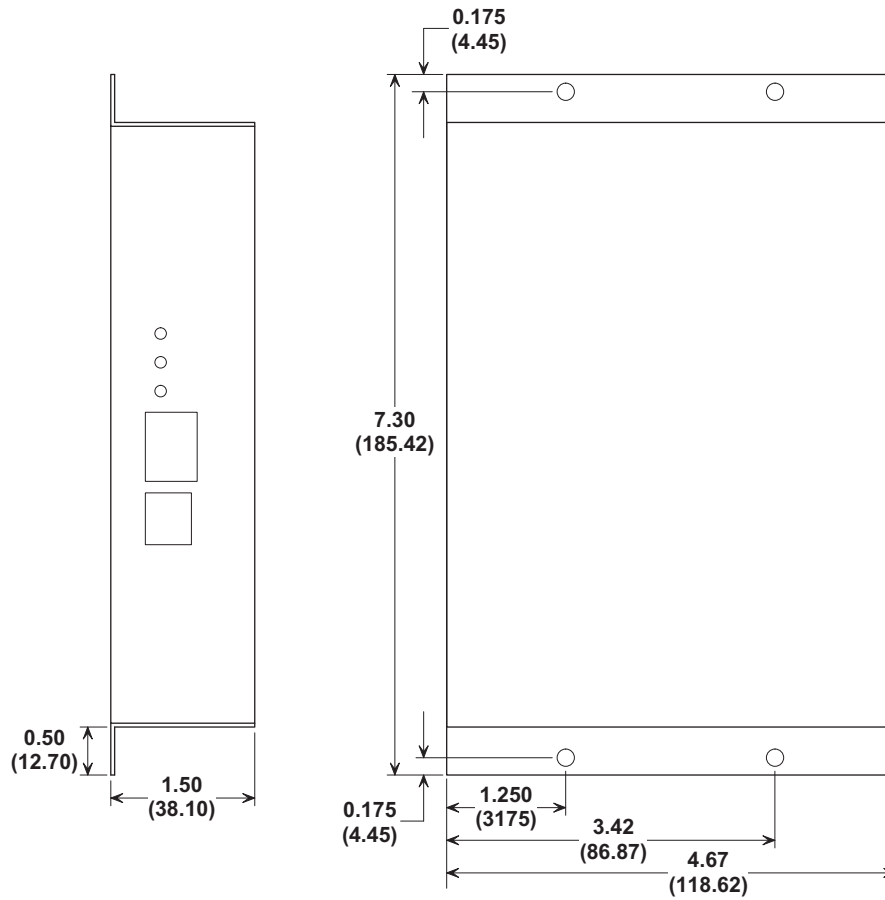

Figure 2

Application Example

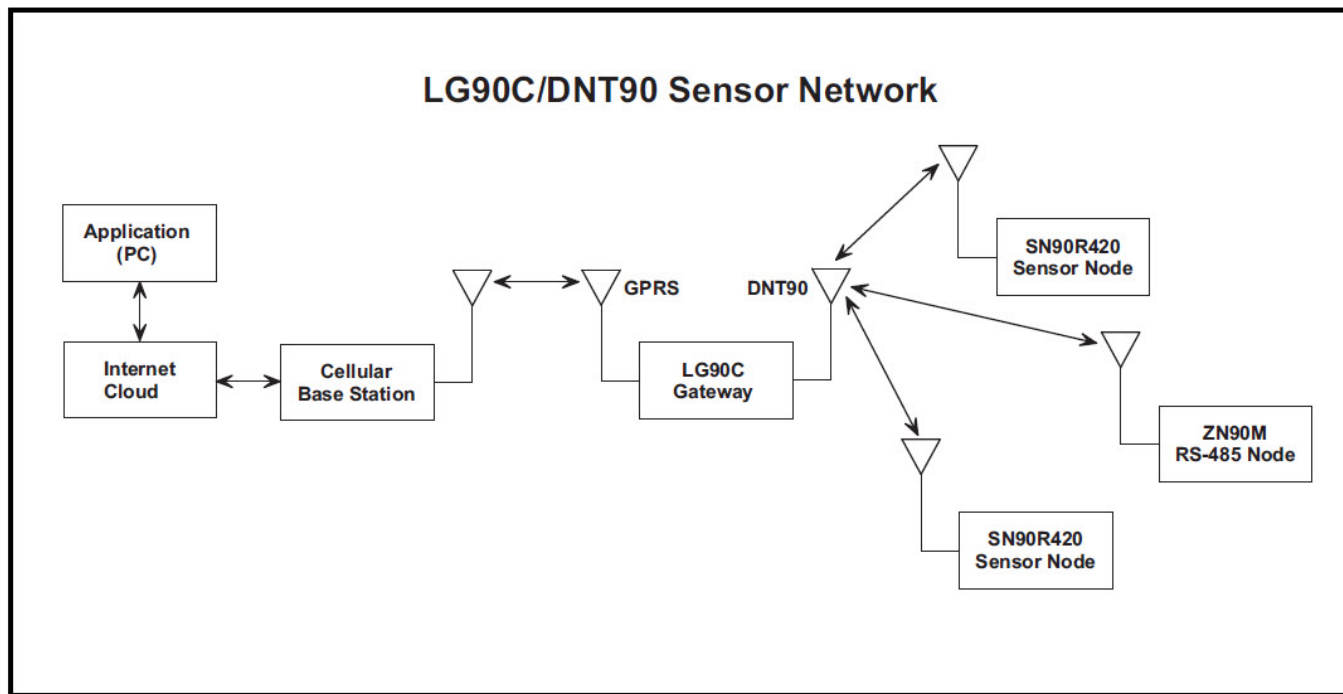

Figure 3