



Chipsmall Limited consists of a professional team with an average of over 10 year of expertise in the distribution of electronic components. Based in Hongkong, we have already established firm and mutual-benefit business relationships with customers from,Europe,America and south Asia,supplying obsolete and hard-to-find components to meet their specific needs.

With the principle of “Quality Parts,Customers Priority,Honest Operation,and Considerate Service”,our business mainly focus on the distribution of electronic components. Line cards we deal with include Microchip,ALPS,ROHM,Xilinx,Pulse,ON,Everlight and Freescale. Main products comprise IC,Modules,Potentiometer,IC Socket,Relay,Connector.Our parts cover such applications as commercial,industrial, and automotives areas.

We are looking forward to setting up business relationship with you and hope to provide you with the best service and solution. Let us make a better world for our industry!



Contact us

Tel: +86-755-8981 8866 Fax: +86-755-8427 6832

Email & Skype: info@chipsmall.com Web: www.chipsmall.com

Address: A1208, Overseas Decoration Building, #122 Zhenhua RD., Futian, Shenzhen, China



THE LEGEND SERIES



MODEL LGB INSTRUCTION MANUAL

INTRODUCTION

The Legend Series LGB is another unit in our multi-purpose series of industrial control products that are field-programmable for solving various applications. This series of products is built around the concept that the end user has the capability to program different personalities and functions into the unit in order to adapt to different indication and control requirements.

The Legend unit LGB, which you have purchased, has the same high quality workmanship and advanced technological capabilities that have made Red Lion Controls the leader in today's industrial market.

Red Lion Controls has a complete line of industrial indication and control equipment, and we look forward to servicing you now and in the future.



CAUTION: Risk of Danger.
Read complete instructions prior to
installation and operation of the unit.



CAUTION: Risk of electric shock.

Table of Contents

GENERAL DESCRIPTION	4
Block Diagram	4
Safety Summary	5
Basic Operation	5
Overflow Indication	6
Inhibit	6
Peak & Valley	7
Normal Operating Mode	7
Front Panel Description	8
Keypad Functions	8
Front Panel Accessible Functions With Program Disable	9
PROGRAMMING GENERAL DESCRIPTION	10
Program Presets & Counter Load Module	11
Program Scale Factors Module	12
PROGRAMMING MENUS	13
Programming Scaling Module	14
Count Scale Factor (COUNT SF)	14
Rate Scale Factor (RATE SF)	14
Count Scale Multiplier (CNT.SCM)	14
Rate Scale Multiplier (RATE SCM)	15
Rate Conversion Factor (RATE PER)	15
Decimal Point (DP)	15
Program Rate Module	16
Program Counter Module	17
Count Modes	17
Process Reset Action	18
Process Automatic Reset	18
Batch Reset Action	19
Batch Automatic Reset	19
Program User Module	20
No Mode	20
Maintained Reset (MNT RST)	20
Momentary Reset (MOM RST)	21
Reset Output (RST OUT)	21

Set Output (SET OUT)	21
View/Freeze Display (VIEW DS1)	21
Change Display (CHG DSP)	21
Counter Load (CNT LD)	21
Print Request (PRINT RQ)	21
Skip Preset 1 (SKIP P1)	21
Skip Preset 3 (SKIP P3)	21
Program Disable (PGM. DIS.)	21
Program Outputs Module	22
Phase	22
Timed, Latched, or Boundary	23
Output End (Reset) Modes	23
Output Power Up State (OFF@P.UP or SAVE@P.DN)	23
Reset Output with Count (RST/C-EN OR DS)	23
Program Display Module	24
Displays 1-4	24
Scroll Speed (SCRO.SPD)	24
Program Communication Port	25
Baud Rate	25
Parity	25
Unit Address	25
Serial Transmit Delay	25
Program Print Options Module	26
Program Options Module	27
Operator Access	27
Preset Tracking	27
User Settings	27
LGB Factory Settings	28
LGB User Settings Chart	30
RS485 SERIAL COMMUNICATIONS	32
Programming Software	32
Installing Software	32
Using Software	32
Communication Format	33
Sending Commands and Data	33
Receiving Data	35

Serial Connections	36
Connecting to a Host Terminal	37
Troubleshooting Serial Communications	38
INSTALLATION & CONNECTIONS	39
Installation Environment	39
EMC Installation Guidelines	40
Wiring Connections	40
AC Power Wiring	41
DC Power Wiring	41
Serial Communications	41
User Input Wiring	41
Output Wiring	41
Relay Connections	41
Signal Wiring	42
Inputs A & B	42
Installation & Removal of Relay Board	43
DIP Switch Set-up	43
Various Sensor Output Connections	44
SPECIFICATIONS	46
TROUBLESHOOTING GUIDE	48
APPENDIX "A" - SCALING FOR COUNT INDICATION	51
Count Scale Multiplier	52
Counter Scaling Example:	53
APPENDIX "B" - SCALING FOR RATE INDICATION	54
Rate Scale Multiplier	55
Rate Scaling Example:	55
APPENDIX "C" - APPLICATION	57
APPENDIX "D" - ORDERING INFORMATION	58
APPENDIX "E" - FLOWCHART FOLD-OUT	(Insert)

GENERAL DESCRIPTION

The Legend unit (LGB) is a two input, microprocessor-based device which features process, batch, and total counting, as well as a time interval rate indicator. Four presets are available, two of which are assigned to the process counter and the other two assignable to the batch, total or rate indicator. The internal count precision is maintained to 9 digits.

The RS485 serial communication port provides for computer and printer interface that extend the capabilities of the unit. It can be used for data retrieval and for programming various data values.

Optional Legend Programming Software (SFLGP) for IBM® compatible PCs is available to program all of the Legend configuration parameters, such as User Inputs, Count modes, etc. The software allows unit configurations to be created, uploaded, downloaded, and saved to a file for rapid programming of the Legend unit.

Application flexibility is provided through the two-line by eight-character alphanumeric display. The display features English language menus for easy viewing and simplified programming. The four scroll-through indication displays can be programmed to show various parameters and to automatically scroll, if desired. A program disable DIP switch used with an external User Input can be utilized to protect the settings and guarantee that no unwanted changes occur during operation.

The five Programmable User Inputs can be set for a variety of functions. Three user inputs are located on the upper rear terminal block and the other two inputs are front panel function keys.

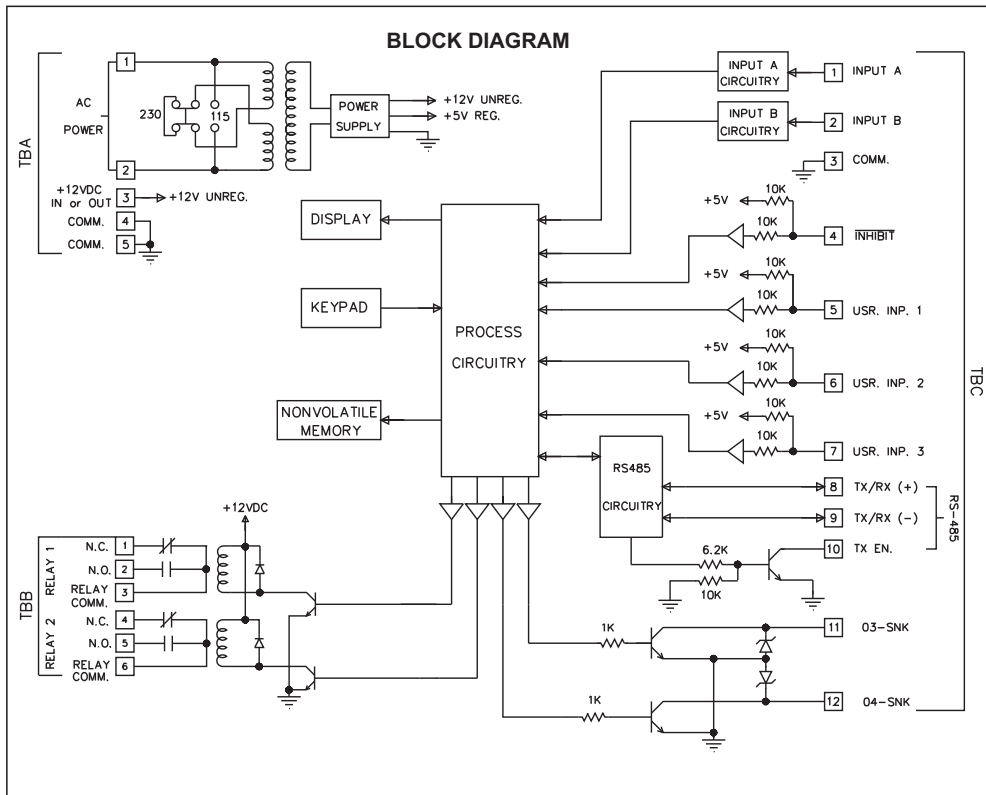

When power is turned off, the unit automatically saves the settings and data in its no-power memory. When power is restored, the LGB restores the parameters it had at power down. The EPROM's life expectancy is at least 100,000 power cycles. The LGB offers a choice of seven programmable counting modes for use in applications requiring Bi-directional, Anti-coincidence, and Quadrature counting. A separate inhibit terminal can be used for any of the count modes.

Input A accepts a signal for the Count (Process & Total) and Rate displays. Input B accepts a signal for the Count (Process & Total) display or direction control. In the Anti-coincidence mode both inputs are monitored simultaneously, so that no counts are lost, and the final count can be chosen as the sum or difference of the two inputs.

Rate and Count (Process & Total) displays have separate scaling and decimal point placement, for the readouts in different units.

The Counter Load feature enables the operator to modify the count value under circumstances that occur when flawed material has been counted and it is necessary to adjust the count value accordingly.

The rate operates in the time interval method ($1/\tau$) to calculate the rate value. This method insures high resolution at all input rates. Averaging can be accomplished by programming the Minimum and Maximum Update Time for the desired response. Extensive scaling capabilities allow practically any reading at very slow input rates.

The plug-in relay board operates with the Process counter and has two, 5 amp, 240 VAC relay outputs. The open collector outputs can be assigned to either the Batch count, Total count, or Rate indicator. The programmable outputs can be set for a variety of functions.

The construction of the Legend LGB unit is a lightweight, high impact plastic case with a clear viewing window. The sealed front panel with the silicone rubber keypad meets NEMA 4X/IP65 specifications for wash-down and/or dusty environments, when properly installed. Plug-in style terminal blocks simplify installation and wiring change-outs.

SAFETY SUMMARY

All safety related regulations, local codes and instructions that appear in the manual or on equipment must be observed to ensure personal safety and to prevent damage to either the instrument or equipment connected to it. If equipment is used in a manner not specified by the manufacturer, the protection provided by the equipment may be impaired.

Do not use this unit to directly command motors, valves, or other actuators not equipped with safeguards. To do so, can be potentially harmful to persons or equipment in the event of a fault to the unit.

BASIC OPERATION

The Legend contains three counters that keep track of the Process Count, Batch Count, and Total Count. The unit takes the actual number of pulses counted (internal count value) and multiplies them by the Count Scale Factor and Count Scale Multiplier. This results in the desired reading value for the Process and Total count displays. The Batch Count will register one count each time a process is completed.

The Process and Batch Counters have three Reset Action modes associated with their displays; Reset to Zero (up-count modes), Reset to Preset (down-count modes), or Reset to the Counter Load value. Both counters can be independently programmed to operate in one of these reset modes. A Reset can be a manual reset, using a programmable user input, or it can be one of the seven programmable Automatic Reset modes. Both the reset action and automatic reset modes are programmed in the Program Counter Module.

The Process Counter displays the scaled number of pulses in the current Batch cycle. The Batch counter will display the number of processes that have been completed. The Batch counter will only increment if the process counter is programmed for one of the automatic reset modes. When the process count equals either preset 1 or 2 depending on the selection of the automatic reset mode, the Batch count will increment by one. The Batch count can also be programmed to automatically reset if desired.

The Total Count is the total number of counts that have been received since the Total was last reset. It can be used to keep a running total of process units on a desired per shift, per day, per week, etc. basis. The Total Count will always reset to zero and requires a manual reset by a user input. The reset can be independent of the process and batch count.

The internal precision of the Process and Totalizing Counter is maintained to 9 digits. The internal precision of the Batch Counter is 7 digits.

BASIC OPERATION (Cont'd)

The signal at Input A is used for the rate indicator portion. The rate indicator uses a time interval method ($1/\tau$) to calculate the rate value. The unit counts on the negative edge of the input pulses. After the programmed minimum update time elapses and the next negative edge occurs, the unit saves the number of edges that occurred during the elapsed time. The number of edges is multiplied by the Rate Scale Factor, Rate Scale Multiplier, and the Rate Conversion Factor to calculate the rate value. Averaging can be accomplished by programming the Rate Minimum Update Time for the desired response. Extensive scaling capabilities allow practically any desired reading at very slow count rates. The following is a Block Diagram overview of the basic operation.

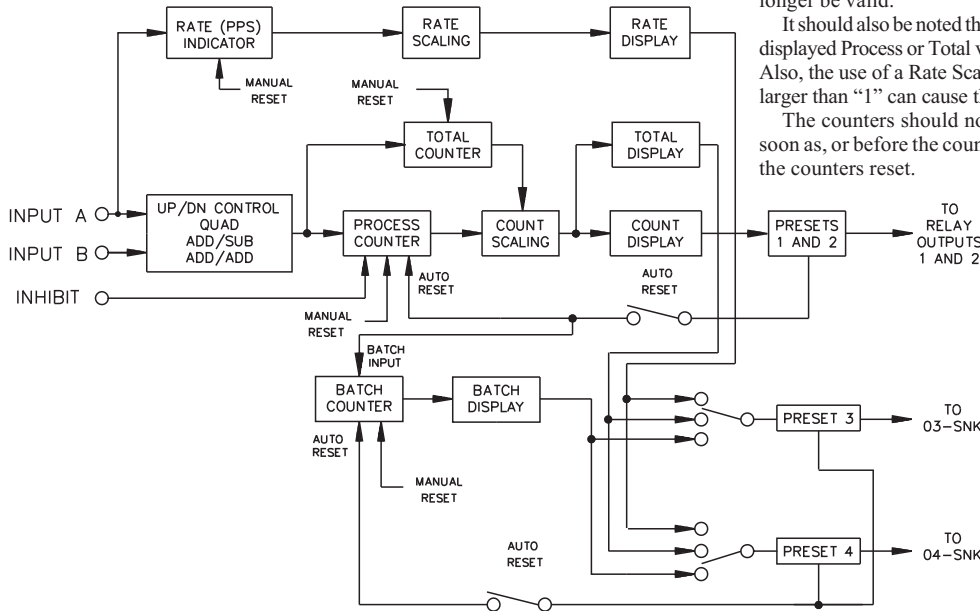

OVERFLOW INDICATION

The Legend will flash the word "OVERFLOW" in the appropriate display when an overflow condition occurs. An overflow occurs if the capacity of the display (6-digits Process & Batch, 8-digits Total) is exceeded or if the internal count capacity (9-digits Process, 7-digits Batch, 11-digits Total) is exceeded. The use of an extremely small Scale Multiplier and a Scale Factor value can cause the internal count capacity to overflow before the displayed value will overflow.

For example, if a Scale Factor of 0.0001 and a Scale Multiplier of 0.001 is used, for every 10,000,000 count edges received, the display will increment by 1. Before the display reaches 215, the internal counter will overflow. When the capacity of the display is exceeded, the count value will be maintained and will be valid. But if the internal count capacity is exceeded, then this value will no longer be valid.

It should also be noted that the use of a Scale Factor larger than "1" could cause the displayed Process or Total value to overflow before 999,999 counts are accumulated. Also, the use of a Rate Scale Factor, Scale Multiplier, and Rate Conversion Factor larger than "1" can cause the rate display to be in an overflow condition.

The counters should not be allowed to operate in an overflow condition. As soon as, or before the counters overflow, the information should be recorded and the counters reset.

INHIBIT

When the Inhibit terminal is low, connected to common, all input pulses will be ignored by the counter. The rate input, however, is unaffected by the Inhibit terminal and will continue to indicate the rate of the signal at input A. When the Inhibit terminal is high, the signal for the counter will be sensed and counted.

PEAK & VALLEY

The Peak and Valley registers will record the lowest (Valley) and the highest (Peak) readings of the rate input signal. These values are viewed in the indication display loop and are updated automatically. A user input can be programmed to reset the values to the current rate value individually or by sending the proper command via the serial communication port. The Peak and Valley values are NOT retained when power to the unit is removed.

NORMAL OPERATING MODE

In the normal operating mode, the up, down, left, and right arrow keys are used to scroll through the main display loop. In the main display loop, the four indication displays, scale factor, and program mode module are viewed, as shown below. In the indication display loop, the up and down arrow keys are used to scroll to each display. The indication displays are referenced as 1 (RATE), 2 (PEAK), 3 (VALLEY), and 4 (PROCESS), and are the factory default settings. The indication displays can be programmed to show other parameters and automatically scroll if desired (Refer to the Program Displays Module). When exiting the indication display loop, using the left or right arrow keys, the last display that was viewed will be the first display to be viewed when re-entering the indication display loop. Also, the last indication display that was viewed at power down, will be the one viewed on power up.

The Presets and Counter Load values are accessed from any of the indication displays or from the programming loop. The Count and Rate scale factors are accessed from the Scale Factors display or when in the programming loop from the Program Scaling module. In the Program Mode display, the operator enters the programming loop to access all parameters to configure the unit. Shown at the right is the Main Display Loop.

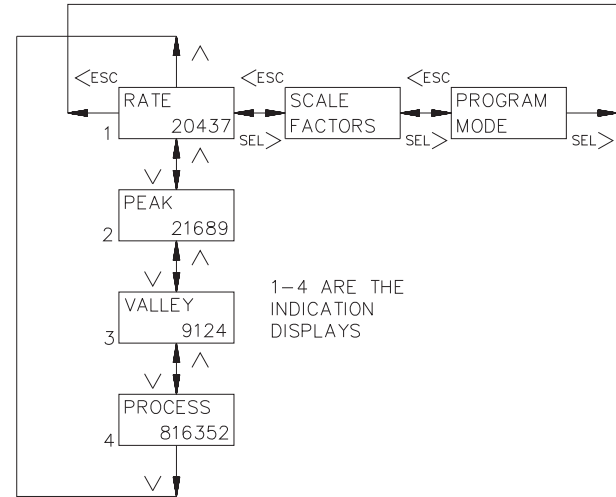

1-4 ARE THE
INDICATION
DISPLAYS

FRONT PANEL DESCRIPTION

The front panel has a clear viewing window to view the two line by eight character LCD display with yellow/green or red backlighting. The front panel meets NEMA 4X/IP65 requirements when properly installed. The keypad has a key array of two rows by four columns and some keys have a dual function. The following is a description of each key:

KEYPAD FUNCTIONS

- F1** - Function key F1 is a User Programmable Input. When the key is pressed, the unit performs the appropriate function as programmed in the “Program User Module”.
- F2** - Function key F2/RST is a User Programmable Input. When the key is pressed, the unit performs the appropriate function, as programmed in the “Program User Module”. The “RST” printing on this key is used as a quick reference for the operator, as long as the function key is programmed for a reset function.
- PRIS** - The PRS key accesses the Preset and Counter Load Module provided these values are not programmed for ‘loc’k. If all values are ‘loc’ked, pressing the PRS key does nothing. Preset values that are accessible (changeable), can be changed immediately. Within the preset menu, pressing this key saves the value and advances the display to the next available preset. Pressing the PRS key at the end of the module exits the module and returns the user to the main display loop.
- <ESC** - The Left arrow/escape key scrolls to the left in the main display loop. When programming a numerical value, it selects the digit to the left. In a sub-menu, it will exit to the next higher level menu in the loop. It is also used to exit the programming loop. When exiting the programming loop, the Legend will store all the parameters into nonvolatile memory and return to the last viewed indication display.

KEYPAD FUNCTIONS (Cont’d)

- ▲** - The Up arrow key scrolls through the indication displays. In the programming loop, this key can be used to scroll through the main menus. When programming a numerical value, it increments (decrements, i.e., goes more positive, for negative values) at the selected digit position. If the key is pushed and held, the value will scroll (count up) automatically. After 5 counts, the unit enters fast scroll mode. If the key remains pushed, a digit shift occurs every one hundred counts until the maximum value or zero (for negative presets) is reached. When the digit shift occurs, the previously scrolling digit goes to zero. When zero is reached (for negative values), the display holds at zero. To go positive, the key must be released and pushed again.
- V** - The Down arrow key scrolls through the indication displays. In the programming loop, it scrolls through the main menus and sub menus. When programming a numerical value, it decrements (increments or goes more negative, for negative values) at the selected digit position. If the key is pushed and held, the value will auto scroll (count down automatically). After 5 counts, the unit enters fast scroll mode. If the key remains pushed, a digit shift occurs every one hundred counts until zero is reached. When the digit shift occurs, the previously scrolling digit goes to zero. When zero is reached, the display holds at zero. To go negative, the key must be released and pushed again.
- ENT** - The Enter key enters the programming loop, when “Program Mode” is displayed from the main display loop. When “Scale Factors” is displayed, pressing Enter allows access to the scale factors. This key is also used to save changes to data values. If the data value is a preset or counter load value, the value is entered and the preset menu is exited. For all other numeric data values (i.e., Output time, Rate update times, etc.), the value is entered and the value edit mode is exited. The value is still viewed in the display, but with no digits flashing.
- SEL>** - The Select/Right arrow key scrolls right in the main display loop. When programming a numerical value, it selects the digit to the right. In a sub-menu loop, it is used to go to the next lower level and eventually into an edit menu.

FRONT PANEL ACCESSIBLE FUNCTIONS WITH PROGRAM DISABLE

The Legend has several ways to limit the programming of parameters from the front panel keypad. There is an Operator Access module, in the programming loop, that is used with the Program Disable (PGM.DIS.) DIP switch and an external programmable user input. Only an external user input can be selected for program disable. The following list describes the possible program disabling functions.

PGM.DIS. SWITCH	User Input Terminal	Action
OFF	Inactive	All programming enabled
OFF	Active	Operator Accessible Functions Enabled, Programming Loop Disabled
ON	Inactive	Same as previous mode.
ON	Active	Operator Accessible Functions Disabled, Programming Loop Disabled

Note: If the user input, set for PGM. DIS., is to be changed to another function, make sure the user input is not low (active). If it is low and the mode is changed, the program disable modes will operate as if a PGM. DIS. user input were active.

PROGRAMMING GENERAL DESCRIPTION

Programming the Legend unit is done through the front panel keypad, which allows the user to enter into Main Menus, Sub-Menus, and Edit Menus. The English language prompts, the flashing parameters values, and the front panel keypad aids the operator during programming.

Although the unit has been programmed at the factory, the parameters will generally have to be changed to suit the desired application. From the main display loop, the main menus are entered by pressing the enter (ENT) key when program mode is displayed. This allows the user to then enter a sub-menu from a main menu where parameter values can be viewed. From the sub-menu the operator can advance into an edit menu. An edit menu is where a parameter value is changed and entered. There are two types of edit menus:

1. A Choice Edit Menu allows the operator to scroll through options by repeatedly pressing the down arrow key until the desired option is viewed. The option is selected by pressing the ENT (enter) key, which returns the operator to the previous sub-menu. The operator can exit the edit menu WITHOUT making a selection by pressing the <ESC key, which will return the operator to the previous sub-menu.
2. In a Numerical Value Edit Menu, the operator uses the left or right arrow key to select a digit. The up and down arrow keys change the digit's value. The PRS key toggles the left most digit between a minus (-) and a zero for plus (+), for that numeric value. When the appropriate numerical value is selected, it is entered by pressing the ENT (enter) key, which returns the operator to the previous sub-menu.

All parameter values that are changed in the Programming Loop are saved when exiting the loop. The operator can exit the programming loop from any of the main menus by pressing the <ESC key. When the <ESC key is pressed, the display will blank momentarily, while the parameter values are saved in nonvolatile memory. The unit will return to the indication display that was last viewed. Shown is the Main Display Loop and the Main Programming menus of the Four Preset Batch Legend (LGB) unit.

All of the flowcharts that follow which have slanted characters that will be flashing in the unit's display and will have programmable options.

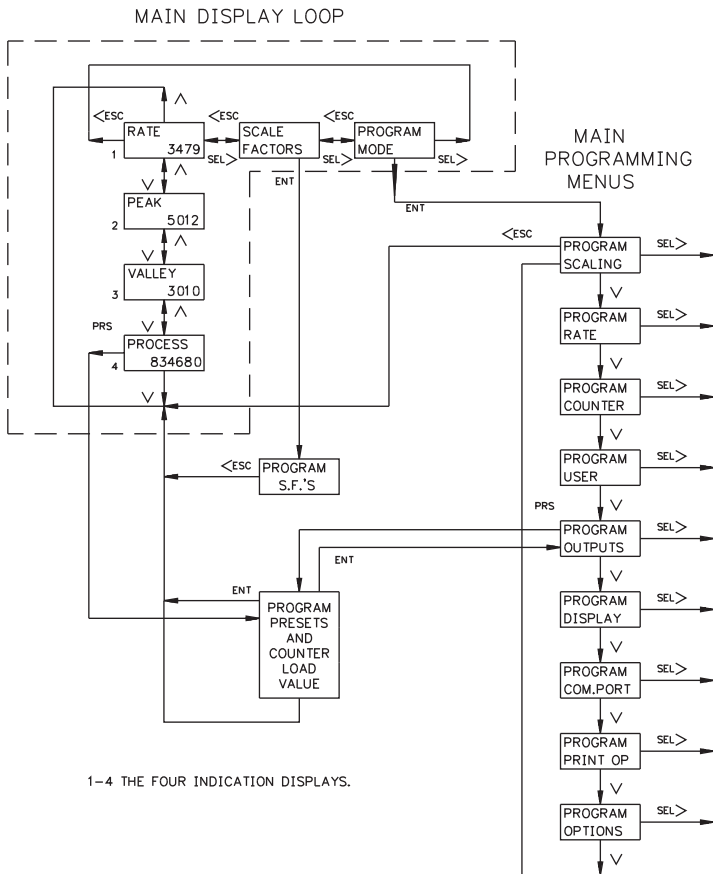

PROGRAM PRESETS & COUNTER LOAD MODULE

The Preset and Counter Load values are accessed from any of the indication displays, or from any of the main menus in the programming loop, by pressing the PRS key. The top line shows the Preset number and the display that it is assigned to (P = Process, B = Batch, T = Total, R = Rate). The following flowchart shows only the Preset and Counter Load portion:

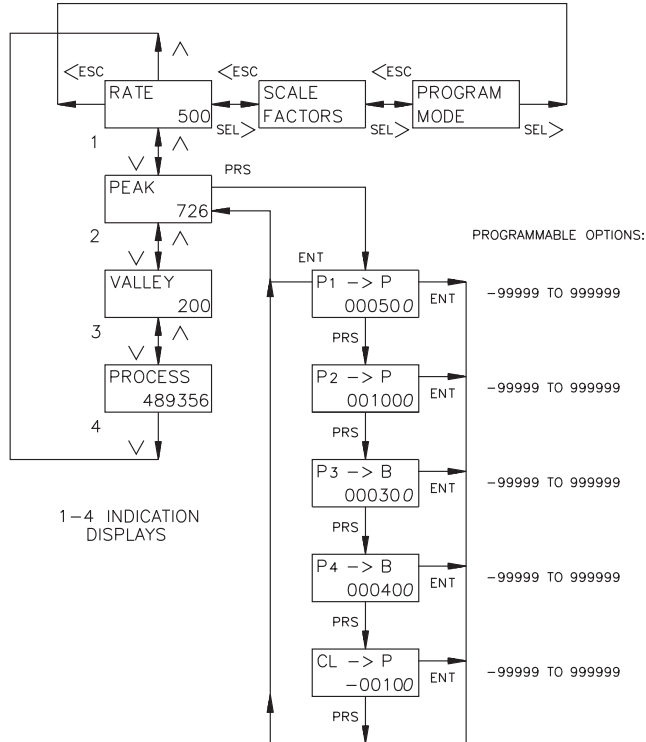

PRESETS VALUES

Preset values P1 and P2 activate relay outputs one and two respectively, when the process counter display value equals the preset value. Outputs (presets) one and two are assigned to the process count display. Presets P3 and P4 activate solid state outputs 03-SNK & 04-SNK respectively, when the assigned display equals the preset value. Outputs (presets) three and four can be assigned to either the Batch counter, Total counter, or Rate indicator display. The output action (timed, latched, or boundary) is programmed in the Program Outputs Module. The preset values may range from -99,999 to 999,999.

The Count Scale Factor, will have a direct effect on the preset value being entered, when the output (preset) is assigned to a counter display. For a Scale Factor value greater than "1", the preset value should be a whole number multiple of the Scale Factor value. If it is not, the Legend will automatically adjust the preset value up or down to force it to be evenly divisible by the Scale Factor.

COUNTER LOAD VALUE

The Counter Load value (CL) allows the user to change the process or batch count value. The count display will reset to the counter load value, if the reset mode is set to counter load (in the Program Counter Module). The counter load value can be programmed from -99999 to 999999.

PROGRAM SCALE FACTORS MODULE

The Scale Factors are accessed from the Scale Factors module in the main display loop or from the Scaling module in the programming loop. Since the Scale Factors may need to be changed periodically, this module allows the operator to change a scale factor value WITHOUT entering the programming loop. The following flowchart shows only the Scale Factor portion:

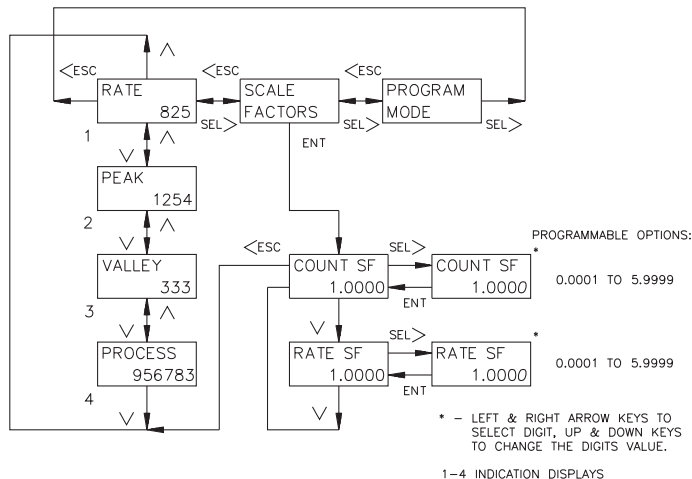

COUNT SCALE FACTOR

The number of pulses counted (internal count value) is multiplied by the Count Scale Factor value and the scale multiplier to obtain the desired Process and Total Count display values. A Count Scale Factor value of 1.0000 and a Scale Multiplier of "1" will result in the display of the actual number of input pulses that were counted. The Count Scale Factor value is used for converting the number of pulses counted to the required units of measure for the display. This includes conversion from different units of measure (i.e feet to meters, etc.).

The Count Scale Factor value can range from 0.0001 to 5.9999. It is important to note that the precision of a counter application cannot be improved by using a Scale Factor greater than "1". To accomplish greater precision, more pulse information must be generated per measuring unit. For details, refer to Scaling for Count Indication in the Appendix.

RATE SCALE FACTOR

The internal rate value (pulses per second) is multiplied by the Rate Scale Factor, Rate Scale Multiplier, and Rate Conversion Factor values, to obtain the desired rate display value. The Rate Scale Factor value is used for converting the internal rate (in pulses per second) to the required units of measure for the display. This includes conversion from different units of measure (i.e feet to meters, etc.).

The Rate Scale Factor values range from 0.0001 to 5.9999. Due to the way the rate is calculated, high resolution and accuracy are achieved at all input rates, slow or fast. For details, refer to Scaling for Rate Indication in the Appendix.

PROGRAMMING MENUS

The programming menus are accessed when “Program Mode” is displayed in the main display loop. All parameter values can be accessed from the Main Programming Menus. Accessibility to the programming menus will depend on the Program Disable Function setting (Refer to Front Panel Accessible Functions with Program Disable section).

In the programming menus, pressing the down arrow key will scroll through all the main menu options. From the main menu, a sub-menu is accessed by pressing the SEL> key. In a sub-menu, the operator can view the parameter values that are currently selected. To change a parameter value, the edit menu is accessed by pressing the SEL> key. (Refer to Programming General Description section).

The Preset and Counter Load module can be accessed from any main programming menu by pressing the PRS key. When exiting the preset and counter load module, the operator will return to the last main menu that was being viewed. When all parameter changes have been made, the operator can exit the programming loop, from any main menu, by pressing the <ESC key. Exiting will save all parameter values and return the operator to the last indication display that was viewed. Shown are all of the main programming menus:

PROGRAMMING SCALING MODULE

In the scaling module, the Count and Rate Scale Factors, scale multipliers, rate conversion factor, and decimal points are accessed. The following flowchart shows only the Scaling portion:

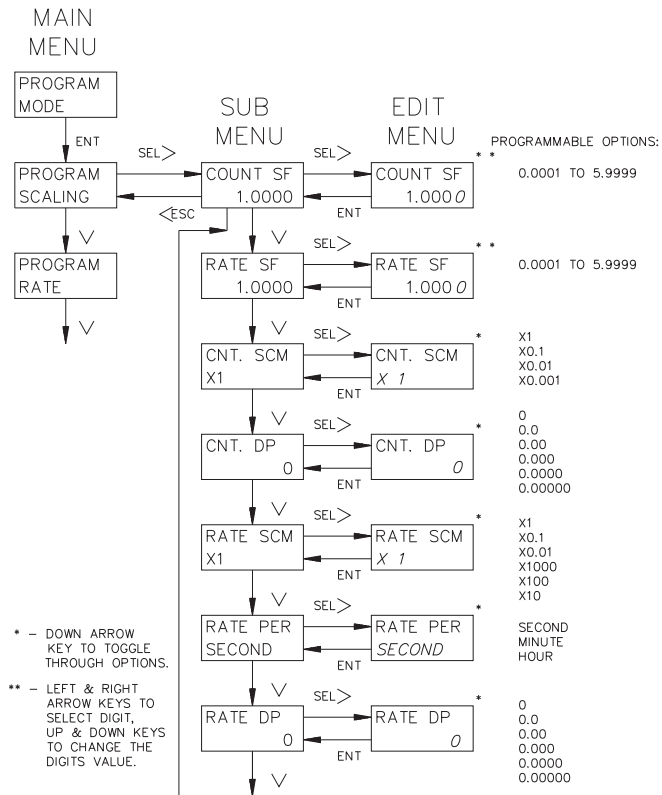

COUNT SCALE FACTOR (COUNT SF)

The number of pulses counted (internal count value) is multiplied by the Count Scale Factor value and the Count Scale Multiplier to obtain the desired Process and Total Count display values. A Count Scale Factor value of 1.0000 will result in the display of the actual number of input pulses that were counted. The Count Scale Factor value is used for converting the number of pulses per unit of measure to the required units of measure for the display. This includes conversion from different units of measure (i.e feet to meters, etc.).

The Count Scale Factor value can range from 0.0001 to 5.9999. It is important to note that the precision of a counter application cannot be improved by using a Scale Factor greater than "1". To accomplish greater precision, more pulse information must be generated per measuring unit. For details, refer to Scaling for Count Indication in the Appendix.

RATE SCALE FACTOR (RATE SF)

The internal rate value (pulses per second) is multiplied by the Rate Scale Factor, Rate Scale Multiplier, and Rate Conversion Factor values, to obtain the desired rate display value. The Rate Scale Factor value is used for converting the internal rate (in pulses per second) to the required units of measure for the display. This includes conversion from different units of measure (i.e feet to meters, etc.).

The Rate Scale Factor value can range from 0.0001 to 5.9999. Due to the way the rate is calculated, high resolution and accuracy are achieved at all input rates, slow or fast. For details, refer to Scaling for Rate Indication in the Appendix.

Note: Since the Process Count and Rate Scale Factors may need to be changed periodically, they can also be accessed from the Scale Factors module in the main display loop.

COUNT SCALE MULTIPLIER (CNT.SCM)

There are four Count Scale Multipliers available; X 1, X 0.1, X 0.01, or X 0.001 that change the Process and Total count display values accordingly. The number of pulses counted (internal count value) is multiplied by the scale multiplier and the scale factor values to obtain the desired Process and Total Count displays.

Note: Use of a small scale multiplier with a small scale factor could cause the internal count value to be exceeded, before the 6-digit display value is exceeded.

RATE SCALE MULTIPLIER (RATE SCM)

The Rate Scale Multiplier is used with the rate scale factor and rate conversion factor to scale the rate display value for the proper units of measure. The scale multipliers available are; X 1, X 0.1, X 0.01, X 1000, X 100, or X 10.

RATE CONVERSION FACTOR (RATE PER)

The Rate Conversion Factor is used to display the rate value in the proper time units of measure, per second (X1), per minute (X60), or per hour (X3600) for the desired time units for the Rate display.

DECIMAL POINT (DP)

There are six Decimal Point locations available for the Rate and Count displays. The decimal point is programmed individually for the Rate and Count displays. The Count Decimal Point will be the same for the Process and Total displays. The decimal point location programmed for the Rate display will also be the same for the Peak and Valley displays.

PROGRAM COUNTER MODULE

In the Counter module, the count mode, reset action, and automatic reset capability are selected. The following flowchart shows only the Counter portion:

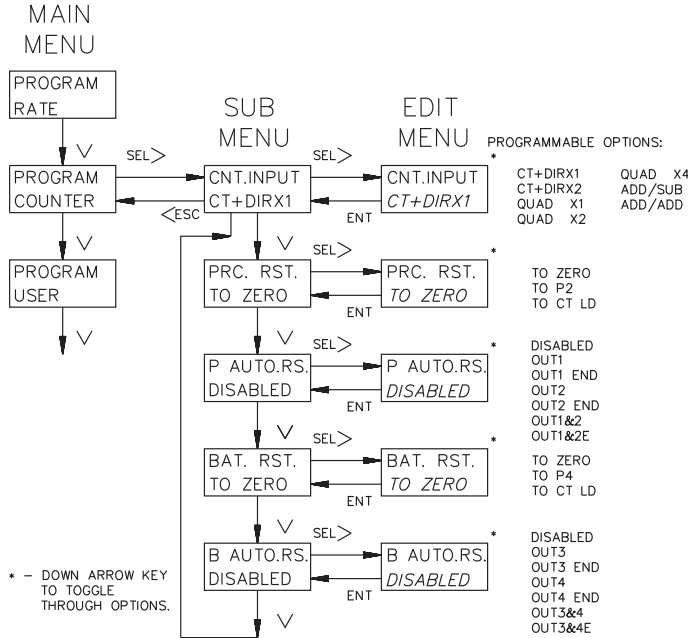

COUNT MODES

There are seven available count modes, which can be used with the separate external Inhibit terminal. Input A signal is used for count and the rate input. Input B is used in combination with Input A for Count Control Direction, Quadrature counting, Anti-coincidence Add/Subtract or Anti-coincidence Add/Add counting applications.

CT+DIRX1 (X1 COUNTING WITH DIRECTION)

The unit will count one count on every negative edge of the input signal at Input A. The direction of the count is determined by the logic state of Input B. A high level at Input B will cause the unit to count in a positive direction. A low level will cause the unit to count in a negative direction. The rate display is NOT affected by the logic state of Input B.

CT+DIRX2 (X2 COUNTING WITH DIRECTION)

The unit will count one count on every negative edge of the input signal and one count on every positive edge of the input signal at Input A. In this mode, the input signal is effectively doubled. The direction of the count is determined by the logic state of Input B. A high level at Input B will cause the unit to count in a positive direction. A low level will cause the unit to count in a negative direction. The rate display is NOT affected by the state of Input B.

QUAD X1 (QUADRATURE X1)

Quadrature counting modes are primarily used in positioning and anti-jitter applications. The reason this mode works is due to the manner in which the two incoming pulses are positioned relative to each other. The pulse signal on Input B is shifted 90° away from the pulse signal at Input A. These two signals are processed by the Legend as follows:

Input A serves as the count and rate input, while Input B serves as the quadrature input. For quadrature with single edge counting, the counter will count in a positive direction when Input A is a negative going edge and Input B is at a low level. The counter will count in a negative direction when Input A is a positive going edge and Input B is at a low level. All transitions on Input A are ignored when Input B is at a high level. These logic rules provide the basis for anti-jitter operation which will prevent false counts from occurring due to back-lash, vibration, chatter, etc.

COUNT MODES (Cont'd)

QUAD X2 (QUADRATURE X2)

When two edge counting is used, the quadrature mode works the same as with single edge counting when Input B is low. But when Input B is a high level, counts at Input A are no longer ignored. Instead, the logic rules for Input A are complemented, allowing both edges of Input A to be counted. This doubles the effective resolution of the encoded input.

QUAD X4 (QUADRATURE X4)

This mode takes the quadrature mode, with two edge counting, one step further. In quadrature times 4, both Input A and Input B serve as the count or quadrature input, depending on their state. In one instance, Input A will serve as the count input and Input B will serve as the quadrature input. In another instance, Input A will be the quadrature input and Input B will be the count input. This enables each edge, positive and negative going, of both inputs, 1 and 2, to be counted. This results in a resolution four times greater than in the basic quadrature X1 mode. As in the other modes, Input A is also used for the rate input.

ADD/SUB (TWO INPUT ANTI/COINCIDENCE ADD/SUBTRACT)

This mode effectively separates count pulses that may simultaneously appear at the two inputs. The Legend unit processes the count pulses into a string of time-separated pulses, so the internal counter will not lose any count pulses. Input A serves as the add input (count increments) and Input B serves as the subtract input (count decrements).

ADD/ADD (TWO INPUT ANTI/COINCIDENCE ADD/ADD)

This mode effectively sums count pulses that may simultaneously appear at the two inputs. The Legend unit processes the count pulses into a string of time-separated pulses so the internal counter will not lose any count pulses. Input A serves as an add input (count increments) and Input B serves as an additional add input (count increments).

PROCESS RESET ACTION

The Process count display can be reset to Zero, Preset 2, or to the Counter Load value. The method of reset for the display can be automatic or by a user input. The type of reset from a user input can be a Maintained or Momentary reset (Refer to Program User Module for details). Automatic reset is covered in the next section.

Note: Response time for a manual reset is 10 msec maximum.

RESET TO ZERO

When reset, the Process Counter Display value will return to Zero.

RESET TO PRESET 2

When reset, the Process Counter Display value will return to the Preset 2 value. Output 2 triggers when count reaches zero. This mode is not recommended for Boundary.

RESET TO COUNTER LOAD

When reset, the Process Counter Display value will return to the Counter Load value.

Note: The counter load reset action should be programmed for only one count display, either the process count or the batch count.

PROCESS AUTOMATIC RESET

The Automatic reset mode can be enabled or disabled. The Process Counter display will automatically reset to the programmed reset action, when one of the automatic reset modes is selected. A manual reset by a user input will cause the count to reset regardless of the automatic reset mode. The following choices are available:

OUT1 (Reset at Beginning Of Output 1)

In this mode, the counter will reset when the count equals the preset 1 value. Output 1 can be timed or latched.

OUT1END (Reset at End Of Timed Output 1)

In this mode, the counter will reset after output 1 has timed out.

OUT2 (Reset at Beginning Of Output 2)

In this mode, the counter will reset when the count equals the preset 2 value. Output 2 can be timed or latched.

OUT2END (Reset at End Of Timed Output 2)

In this mode, the counter will reset after output 2 has timed out.

OUT1&2 (Reset at Beginning Of Output 1 or Output 2)

In this mode, the counter will reset, when the count equals either preset 1 or preset 2 value. Outputs 1 and 2 can be Timed or Latched.

OUT1&2E (Reset at End Of Timed Output 1 or Output 2)

In this mode, the counter will reset, after output 1 or output 2 has timed out.

Notes:

1. For Auto Reset modes, when operating between approximately $\frac{1}{2}$ to maximum count rate, all other presets should not occur within 1 to 6 counts following the process count value at which Auto Reset occurs. In Reset to Zero modes with positive preset values, this would apply to count values between 0 and 6. For Reset to Preset or Counter Load modes, it would apply to preset values between 0 to 6 less than the Preset 2 value (when positive).
2. For Auto Reset modes, no other process count presets should be set to the same count value at which Auto Reset occurs (Preset 2 or zero for Reset to Preset or Counter Load mode). If they are, only the Auto Reset output will activate. If the process counter is set to Auto Reset at OUT1 & 2, and other preset are the same as Preset 2 (or zero for Reset to Preset mode), only Output 2 will activate. If the unit is set to Auto Reset at OUT1, only Outputs 1 and 2 will activate.

BATCH RESET ACTION

The Batch count display can be reset to zero, Preset 4, or to the Counter Load value. The method of reset for the display can be automatic or by a user input. The method of reset from a user input can be a Maintained or Momentary reset (Refer to Program User Module for details). Automatic reset is covered in the next section.

Note: Response time for a manual reset is 10 msec maximum.

RESET TO ZERO

When reset, the Batch Counter Display value will return to Zero.

RESET TO PRESET 4

When reset, the Batch Counter Display value will return to the Preset 4 value. Output 4 triggers when count reaches zero.

RESET TO COUNTER LOAD

When reset, the Batch Counter Display value will return to the Counter Load value.

Note: The counter load reset action should be programmed for only one count display, either the process count or the batch count.

BATCH AUTOMATIC RESET

The Automatic reset mode can be enabled or disabled. The Batch Counter display will automatically reset to the programmed reset action, when one of the automatic reset modes is selected. A manual reset by a user input will cause the count to reset regardless of the automatic reset mode. The following choices are available:

OUT3 (Reset at Beginning Of Output 3)

In this mode, the counter will reset when the count equals the preset 3 value. Output 3 can be timed or latched.

OUT3END (Reset at End Of Timed Output 3)

In this mode, the counter will reset after output 3 has timed out.

OUT4 (Reset at Beginning Of Output 4)

In this mode, the counter will reset when the count equals the preset 4 value. Output 4 can be timed or latched.

OUT4END (Reset at End Of Timed Output 4)

In this mode, the counter will reset after output 4 has timed out.

OUT3&4 (Reset at Beginning Of Output 3 or Output 4)

In this mode, the counter will reset when the count equals either preset 3 or preset 4 value. Outputs 3 and 4 can be Timed or Latched.

OUT3&4E (Reset at End Of Timed Output 3 or Output 4)

In this mode, the counter will reset after output 3 or output 4 has timed out.

MAINTAINED RESET (MNT RST) (Cont'd)

TOTAL: Resets the total count value to zero. With Maintained reset, the value is held reset as long as the User Input or Function key is active. The unit will start updating the appropriate display when no longer in reset. Maintained reset is level sensitive and overrides an automatic reset mode.

MOMENTARY RESET (MOM RST)

Momentary reset has the same four selectable options as Maintained reset. With Momentary reset, the value resets when the user input or function key is activated. The value will start updating (counting) after the reset action has occurred, even if the user input or function key is still active. Momentary reset is negative edge sensitive and overrides an automatic reset mode.

RESET OUTPUT (RST OUT)

The operator can select to have any or all of the Outputs, 1 through 4, reset. If the output is active, it will reset to its inactive state when the user input or function key is activated. This is a momentary reset.

Note: The Inactive State of an output can be ON or OFF depending on what the Phase is programmed in the Program Outputs Module.

SET OUTPUT (SET OUT)

The operator can select to have any or all of the Outputs, 1 through 4, set. If the output is inactive, it will go (set) to its active state when the user input or function key is activated. If an output is programmed with a time delay and this user input is activated, the output will NOT latch, but will time out after the time delay value expires. This is a momentary reset.

Note: The Active state of an output can be ON or OFF depending on what the Phase is programmed in the Program Outputs Module.

VIEW/FREEZE DISPLAY (VIEW DS1)

When a User Input is activated, an indication display will be viewed and the numeric value for that display will be held. If the operator is in the main display loop, the unit will advance to the indication display to be viewed. If more than one user input is used for this option, the input with the highest priority will be the only one that will hold (freeze) the display. Also, it will be the only input, when activated, that will advance to the indication display from the main display loop. Any other user input programmed, will only advance in the indication display loop. DS1 selects display 1, DS2 display 2, DS3 display 3, and DS4 display 4. The values that are viewed/frozen on the display are determined by what is selected in the Program Displays Module.

*Note: If an external and a front panel user are both selected for this option, the display will be viewed but the numeric value will **NOT** freeze when either user input is activated.*

CHANGE DISPLAY (CHG DSP)

In the indication display loop, when a user input is activated, the indication display will toggle to the next indication display. The change of display is a momentary action.

COUNTER LOAD (CNT LD)

When a user input is activated, the process count value is reset to the counter load value, regardless of the reset action mode. If the batch reset mode is programmed for counter load, the batch value will reset to the counter load value.

Note: The counter load reset action should be programmed for only one count display, either the process count or the batch count.

The counter load is a maintained action.

PRINT REQUEST (PRINT RQ)

When a user input is activated, the unit transmits all the information selected in the Print Options Module via the RS485 serial port. The print request is a maintained action.

SKIP PRESET 1 (SKIP P1)

Output 1 will NOT activate and an automatic reset will NOT occur, when the count value equals preset 1 if the user input is active. This mode is typically used with the Automatic Reset at output 1 or output 2 mode, or the reset after timed output 1 or 2 mode. The skip preset 1 is maintained.

SKIP PRESET 3 (SKIP P3)

Output 3 will NOT activate and an automatic reset will NOT occur, when the count value equals preset 3 if the user input is active. This mode is typically used with the Automatic Reset at output 3 or output 4 mode, or reset after timed output 3 or 4. The skip preset 3 is maintained.

PROGRAM DISABLE (PGM. DIS.)

Only one external User Input can be used for this option. This option used with the Program Disable DIP switch can limit operator access to programmable parameters (Refer to Operator Accessible Functions with Program Disable section). The program disable is maintained.

PROGRAM OUTPUTS MODULE

Presets 1 and 2 activate relay Outputs 1 and 2 respectively. The outputs with presets are assigned to the Process Count display. Output 2 has the same programmable options as Output 1, except the “OUT1 END” sub-menu will be “OUT2 END” and the options are: DISABLED, @OUT1, @OUT1 END.

Presets 3 and 4 activate solid state Outputs 3 and 4 respectively. The outputs can be assigned to either the Batch Count, Total Count, or Rate indication display and the preset values will automatically be assigned to the appropriate display.

Outputs 3 and 4 have the same programmable options as Output 1, except they do not have the Out End mode option in the 2nd sub-menu. Also, the Boundary mode can only be selected when the output is programmed for Rate.

A manual reset, which requires the use of a User Input, will override a timed output. If boundary or latched is selected for the output mode the time value will not appear as an option. The following flowchart shows only the Outputs portion:

PHASE

The positive (+) phase of an output indicates that when the display value equals the preset value, the output will turn on. When the output is reset it will be turned off.

A minus (-) phase mode refers to the complementing of the logic state of the output. When the display value equals the preset value, the output will turn off. The reset condition of the output is the on state. When an output is changed to the other phase it will not take effect until a manual reset or power down is performed.

Note: The state of the relay, if used, will be the same as the solid state output.

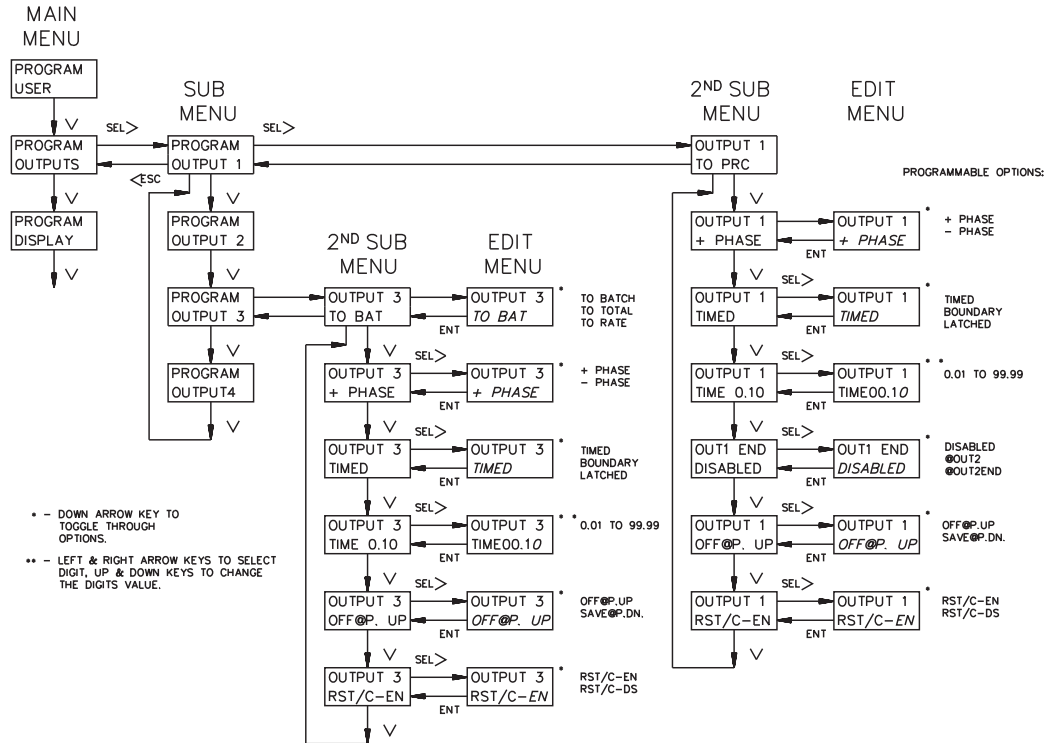

TIMED, LATCHED, OR BOUNDARY

Timed mode can be programmed from 0.01 to 99.99 seconds. When the display value equals the preset value, the output will be active for the time selected. After the time value expires, the output will return to its inactive state. An output may appear to be latched if the time delay is longer than the time required for the counter to reach the preset value. When an output is assigned to the rate display, the output will appear to be latched, if the output time delay is greater than the minimum update time. The output will deactivate when the rate drops below the preset value and the output time expires.

An output selected for the Latched mode will be active when the display value equals the preset value. The output will stay active until it is manually reset by a User Input selected for that function. When the unit is reset, the output will return to its inactive state.

An output selected for the Boundary mode will be active when the display value is greater than or equal to the positive preset value. If the display value is less than the positive preset value, the output will be inactive. For negative preset values, the output will be active when the count value is less (more negative) than the negative preset value. The output will be inactive when the display value is greater (more positive) or equal to the negative preset value. If outputs 1 or 2 are programmed for boundary, the Output End (Reset) modes will not be applicable and therefore will not appear in the display.

OUTPUT END (RESET) MODES

The Output End modes operate with a timed or latched output mode. If either output is selected as boundary, the Output End modes will NOT be available. Output End modes apply only to outputs one and two.

OUTPUT 1

@OUT2 (Output 1 End at Output 2 Start)

Output 1 will reset, return to its inactive state, when output 2 becomes active.

@OUT2END (Output 1 End at Timed Output 2 End)

Output 1 will reset, return to its inactive state, when output 2's time delay expires.

OUTPUT 2

@OUT1 (Output 2 End at Output 1 Start)

Output 2 will reset, return to its inactive state, when output 1 becomes active.

@OUT1END (Output 2 End at Timed Output 1 End)

Output 2 will reset, return to its inactive state, when output 1's time delay expires.

OUTPUT POWER UP STATE (OFF@P.UP OR SAVE@P.DN)

Each output can be programmed individually to have the state of the output OFF at power up (OFF@P.UP) or saved at power down (SAVE@P.DN). The save at power down option will restore the state of the output to what it was at power down when power is restored. The save at power down option DOES NOT restore a timed output to the active state if the output was active at power down. The OFF at power up option refers to the active state of the output, which is determined by the output phase.

RESET OUTPUT WITH COUNT (RST/C-EN OR DS)

The Reset with Count Enabled will reset the output when a manual reset of the Process or Batch count display is performed by a user input. If Reset with Count is Disabled, the output will NOT reset when a manual reset is performed on the Count value.