



Chipsmall Limited consists of a professional team with an average of over 10 year of expertise in the distribution of electronic components. Based in Hongkong, we have already established firm and mutual-benefit business relationships with customers from,Europe,America and south Asia,supplying obsolete and hard-to-find components to meet their specific needs.

With the principle of "Quality Parts,Customers Priority,Honest Operation,and Considerate Service",our business mainly focus on the distribution of electronic components. Line cards we deal with include Microchip,ALPS,ROHM,Xilinx,Pulse,ON,Everlight and Freescale. Main products comprise IC,Modules,Potentiometer,IC Socket,Relay,Connector.Our parts cover such applications as commercial,industrial, and automotives areas.

We are looking forward to setting up business relationship with you and hope to provide you with the best service and solution. Let us make a better world for our industry!



Contact us

Tel: +86-755-8981 8866 Fax: +86-755-8427 6832

Email & Skype: info@chipsmall.com Web: www.chipsmall.com

Address: A1208, Overseas Decoration Building, #122 Zhenhua RD., Futian, Shenzhen, China



FEATURES

- Highly Integrated System-on-Chip
- High Performance (77.4144 MHz CPU Speed)
- ARM720T™ RISC Core
 - 32-bit ARM7TDMI™ RISC Core
 - 8KB Cache
 - MMU (Windows CE™ Enabled)
 - Write Buffer
- 32KB On-Chip SRAM
- Flexible, Programmable Memory Interface
 - SDRAM Interface
 - 15-bit External Address Bus
 - 32-bit External Data Bus
 - Two Segments (128MB each)
 - SRAM/Flash/ROM Interface
 - 26-bit External Address Bus
 - 32-bit External Data Bus
 - Seven Segments (64MB Each)
- Multi-stream DMA Controller
 - Four 32-bit Burst-based Data Streams
- Clock and Power Management
 - 32.768 kHz Oscillator for Real Time Clock
 - 14.7456 MHz Oscillator and On-chip PLL for CPU and Bus Clocks
 - Active, Standby, Sleep and Stop Power Modes
 - Externally-supplied Clock Options
- Low Power Modes
 - Active Mode: 55 mA (MAX.)
 - Standby Mode: 35 mA (MAX.)
 - Sleep Mode: 5.5 mA (MAX.)
 - Stop Mode 2: 18 μ A
- Watchdog Timer
- Vectored Interrupt Controller
 - 16 Standard and 16 Vectored IRQ Interrupts
 - Hardware Interrupt Priority
 - Software Interrupts
 - FIQ Fast Interrupts
- Three UARTs
 - 16-byte FIFOs for Rx and Tx
 - IrDA SIR Support
 - Supports Data Rates Up to 460.8 kb/s
- Two 16-bit Pulse Width Modulators
- Two Dual Channel Timer Modules
- Real Time Clock
 - 32-bit Up-counter with Programmable Load
 - Programmable 32-bit Match Compare Register
- 64 Programmable General Purpose I/O Signals
 - Multiplexed with Peripheral I/O Signals
- Programmable Color LCD Controller
 - Up to 800 × 600 Resolution
 - Supports STN, Color STN, AD-TFT, TFT
 - Supports 15 Shades of Gray
 - TFT: Supports 64 k Direct Colors or 256 Colors selected from a Palette of 64,000 Colors
 - Color STN: Supports 3,375 Direct Colors or 256 Colors Selected from a Palette of 3,375 Colors
- Synchronous Serial Port
 - Supports Data Rates Up to 1.8452 Mb/s
 - Compatible with Common Interface Schemes
 - Motorola SPI™
 - National Semiconductor MICROWIRE™
 - Texas Instruments SSI
- JTAG Debug Interface and Boundary Scan
- 5 V Tolerant I/O

DESCRIPTION

The LH79520, powered by an ARM720T, is a complete System-on-Chip with a high level of integration to satisfy a wide range of requirements and expectations. The LH79520 combines a 32-bit ARM720T RISC, Color LCD controller, Cache, Local SRAM, a number of essential peripherals such as Direct Memory Access, Serial and Parallel Interfaces, Infrared support, Timers, Real Time Clock, Watchdog Timer, Pulse Width Modulators, and an on-chip Phase Lock Loop. Debug is made simple by JTAG support.

This high level of integration lowers overall system costs, reduces development cycle time and accelerates product introduction. The LH79520's fully static design, power management unit, low voltage operation (1.8 V Core, 3.3 V I/O), on-chip PLL, fast interrupt response time, on-chip cache and SRAM, powerful instruction set, and low power RISC core provide high performance.

To build an advanced portable device, advanced processing capability is required. This capability must come with increased performance in the display system and peripherals, and yet demand less power from batteries. The LH79520 is an integrated solution to fit these needs.

ARM720T and ARM7TDMI are trademarks of Advanced RISC Machines, LTD.

Motorola SPI is a trademark of Motorola, Inc.

National Semiconductor MICROWIRE is a trademark of National Semiconductor Corporation.

Windows CE is a trademark of Microsoft Corporation.

PIN DIAGRAM

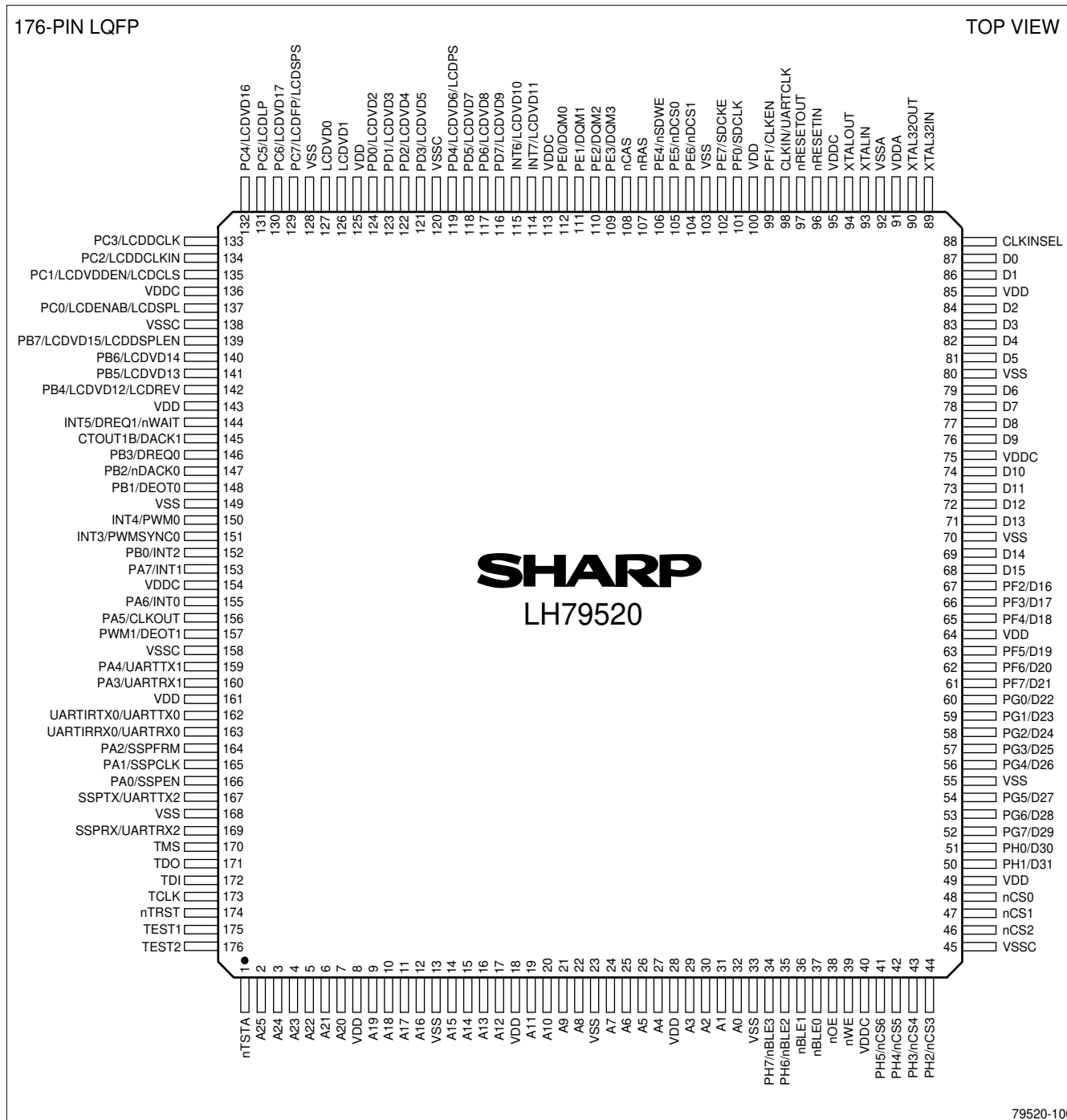
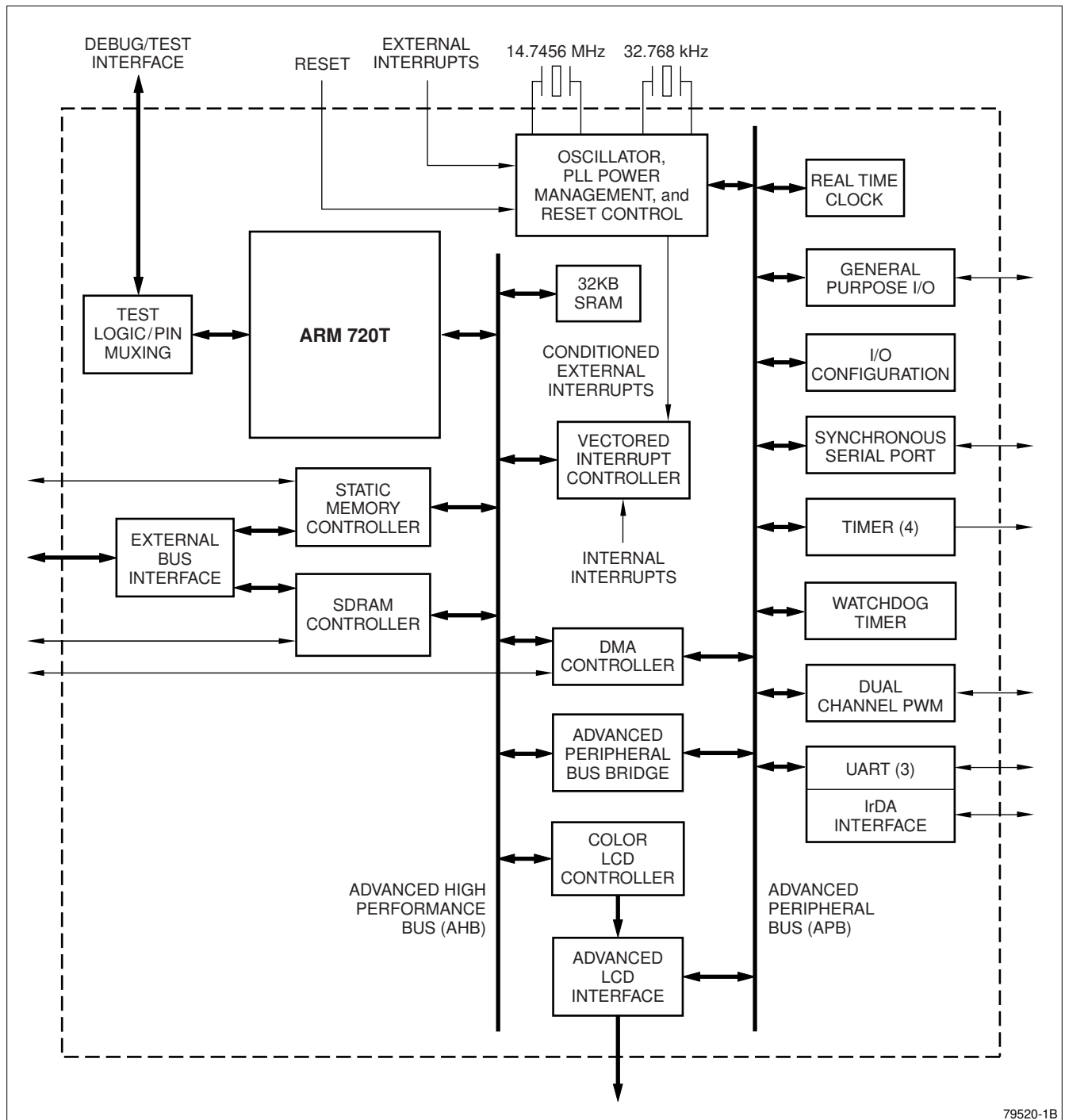

Figure 1. 176-Pin LQFP



79520-1B

Figure 2. LH79520 Block Diagram

SIGNAL DESCRIPTIONS

Table 1. LH79520 Signal Descriptions

PIN NO.	SIGNAL NAME	TYPE	DESCRIPTION	NOTES
MEMORY INTERFACE (MI)				
2-7 9-12 14-17 19-22 24-27 29-32	A[25:0]	Output	Address Signals	
50-54 56-63 65-66 67-69 71-74 76-79 81-84 86-87	D[31:0]	Input/Output	Data Input/Output Signals	1
101	SDCLK	Output	SDRAM Clock	1
109	DQM3	Output	Data Mask Output to SDRAMs	1
110	DQM2	Output	Data Mask Output to SDRAMs	1
111	DQM1	Output	Data Mask Output to SDRAMs	1
112	DQM0	Output	Data Mask Output to SDRAMs	1
102	SDCKE	Output	SDRAM Clock Enable	1
104	nDCS1	Output	SDRAM Chip Select	1
105	nDCS0	Output	SDRAM Chip Select	1
107	nRAS	Output	Row Address Strobe	
108	nCAS	Output	Column Address Strobe	
106	nSDWE	Output	SDRAM Write Enable	1
41	nCS6	Output	Static Memory Controller Chip Select	1
42	nCS5	Output	Static Memory Controller Chip Select	1
43	nCS4	Output	Static Memory Controller Chip Select	1
44	nCS3	Output	Static Memory Controller Chip Select	1
46	nCS2	Output	Static Memory Controller Chip Select	
47	nCS1	Output	Static Memory Controller Chip Select	
48	nCS0	Output	Static Memory Controller Chip Select	
38	nOE	Output	Static Memory Controller Output Enable	
34	nBLE3	Output	Static Memory Controller Byte Lane Enable / Byte Write Enable	1
35	nBLE2	Output	Static Memory Controller Byte Lane Enable / Byte Write Enable	1
36	nBLE1	Output	Static Memory Controller Byte Lane Enable / Byte Write Enable	
37	nBLE0	Output	Static Memory Controller Byte Lane Enable / Byte Write Enable	
39	nWE	Output	Static Memory Controller Write Enable	
144	nWAIT	Input	Static Memory Controller External Wait Control	1, 3
DMA CONTROLLER (DMAC)				
148	DEOT0	Output	DMA 0 End of Transfer	1
147	nDACK0	Output	DMA 0 Acknowledge	1
146	DREQ0	Input	DMA 0 Request	1
157	DEOT1	Output	DMA 1 End of Transfer	1
145	DACK1	Output	DMA 1 Acknowledge	1
144	DREQ1	Input	DMA 1 Request	1, 3

Table 1. LH79520 Signal Descriptions (Cont'd)

PIN NO.	SIGNAL NAME	TYPE	DESCRIPTION	NOTES
COLOR LCD CONTROLLER (CLCDC)				
130 132 139 140 141 142 114 115 116 117 118 119 121 122 123 124 126 127	LCDVD[17:0]	Output	LCD Panel Data bus	1
137	LCDENAB	Output	LCD Data Enable	1
129	LCDFP	Output	Frame Pulse (STN), Vertical Synchronization Pulse (TFT)	1
131	LCDLP	Output	Line Synchronization Pulse (STN), Horizontal Synchronization Pulse (TFT)	1
133	LCDDCLK	Output	LCD Panel Data Clock	1
139	LCDDSPLEN	Output	LCD Display Enable	1
134	LCDDCLKIN	Input	LCD External Clock Input	1
135	LCDVDDEN	Output	LCD Digital Supply Enable	1
135	LCDCLS	Output	LCD Clock Signal for Gate Driver (HR-TFT only)	1
129	LCDSPS	Output	LCD Reset Signal for Row Display (HR-TFT only)	1
142	LCDREV	Output	LCD Reverse Signal (HR-TFT only)	1
137	LCDSPL	Output	LCD Line Start Pulse (Left) (HR-TFT only)	1
119	LCDPS	Output	LCD Power Save (HR-TFT only)	1
SYNCHRONOUS SERIAL PORT (SSP)				
164	SSPFRM	Output	SSP Serial Frame Output	1
165	SSPCLK	Output	SSP Clock	1
166	SSPEN	Output	SSP Data Enable	1
167	SSPTX	Output	SSP Data Out	1
169	SSPRX	Input	SSP Data In	1
PULSE WIDTH MODULATOR (PWM)				
150	PWM0	Output	PWM0 Output	1
151	PWMSYNC0	Input	PWM0 Synchronizing Input	1
157	PWM1	Output	PWM1 Output	1
UART0 (U0)				
163	UARTRX0	Input	UART0 Received Serial Data Input	1
162	UARTTX0	Output	UART0 Transmitted Serial Data Output	1
163	UARTIRRX0	Input	UART0 InfraRed Receive	1
162	UARTIRTX0	Output	UART0 InfraRed Transmit	1

Table 1. LH79520 Signal Descriptions (Cont'd)

PIN NO.	SIGNAL NAME	TYPE	DESCRIPTION	NOTES
UART1 (U1)				
160	UARTRX1	Input	UART1 Received Serial Data Input	1
159	UARTTX1	Output	UART1 Transmitted Serial Data Output	1
UART2 (U2)				
169	UARTRX2	Input	UART2 Received Serial Data Input	1
167	UARTTX2	Output	UART2 Transmitted Serial Data Output	1
GENERAL PURPOSE INPUT/OUTPUT (GPIO)				
153 155 156 159 160 164 165 166	PA7 PA6 PA5 PA4 PA3 PA2 PA1 PA0	Input/Output	General Purpose I/O Signals - Port A	1
139 140 141 142 146 147 148 152	PB7 PB6 PB5 PB4 PB3 PB2 PB1 PB0	Input/Output	General Purpose I/O Signals - Port B	1
129 130 131 132 133 134 135 137	PC7 PC6 PC5 PC4 PC3 PC2 PC1 PC0	Input/Output	General Purpose I/O Signals - Port C	1
116 117 118 119 121 122 123 124	PD7 PD6 PD5 PD4 PD3 PD2 PD1 PD0	Input/Output	General Purpose I/O Signals - Port D	1
102 104 105 106 109 110 111 112	PE7 PE6 PE5 PE4 PE3 PE2 PE1 PE0	Input/Output	General Purpose I/O Signals - Port E	1
61 62 63 65 66 67 99 101	PF7 PF6 PF5 PF4 PF3 PF2 PF1 PF0	Input/Output	General Purpose I/O Signals - Port F. GPIO PF1 is only available when CLKINSEL is '0' (i.e. the external clock source is not being used).	1

Table 1. LH79520 Signal Descriptions (Cont'd)

PIN NO.	SIGNAL NAME	TYPE	DESCRIPTION	NOTES
52 53 54 56 57 58 59 60	PG7 PG6 PG5 PG4 PG3 PG2 PG1 PG0	Input/Output	General Purpose I/O Signals - Port G	1
34 35 41 42 43 44 50 51	PH7 PH6 PH5 PH4 PH3 PH2 PH1 PH0	Input/Output	General Purpose I/O Signals - Port H	1
COUNTER/TIMER (C/T)				
145	CTOUT1B	Output	Counter/Timer Output	1
RESET, CLOCK, AND POWER CONTROLLER (RCPC)				
96	nRESETIN	Input	Reset Input	
97	nRESETOUT	Output	Reset Output	
114	INT7	Input	External Interrupt Input	1
115	INT6	Input	External Interrupt Input	1
144	INT5	Input	External Interrupt Input	1, 3
150	INT4	Input	External Interrupt Input	1
151	INT3	Input	External Interrupt Input	1
152	INT2	Input	External Interrupt Input	1
153	INT1	Input	External Interrupt Input	1
155	INT0	Input	External Interrupt Input	1
93	XTALIN	Input	Crystal Input	
94	XTALOUT	Output	Crystal Output	
89	XTAL32IN	Input	32.768 kHz Crystal Oscillator Input	
90	XTAL32OUT	Output	32.768 kHz Crystal Oscillator Output	
88	CLKINSEL	Input	External Clock Select	
98	CLKIN	Input	External Clock Input (if CLKINSEL = HIGH at reset)	1
99	CLKEN	Output	External Clock Enable (if CLKINSEL = LOW at reset, then this pin functions as PF1)	1
156	CLKOUT	Output	Clock Out (selectable from the internal bus clock or 32.768)	1
98	UARTCLK	Input	External UART Clock Input (with CLKSEL = LOW)	1
TEST INTERFACE				
174	nTRST	Input	JTAG Test Reset Input	
170	TMS	Input	JTAG Test Mode Select Input	
173	TCLK	Input	JTAG Test Clock Input	
172	TDI	Input	JTAG Test Serial Data Input	
171	TDO	Output	JTAG Test Data Serial Output	
175	TEST1	Input	Tie LOW for Normal Operation (has internal pull-down).	
176	TEST2	Input	JTAG Debug Enable: Tie LOW for Normal Operation; pull HIGH to enable JTAG Debugging (has internal pull-down).	
1	nTSTA	Input	Tie HIGH for Normal Operation (has internal pull-up).	

Table 1. LH79520 Signal Descriptions (Cont'd)

PIN NO.	SIGNAL NAME	TYPE	DESCRIPTION	NOTES
POWER AND GROUND (GND)				
40 75 95 113 136 154	VDDC	Power	Core Power Supply	
45 120 138 158	VSSC	Ground	Core GND	
8 18 28 49 64 85 100 125 143 161	VDD	Power	Input/Output Power Supply	
13 23 33 55 70 80 103 128 149 168	VSS	Ground	Input/Output GND	
91	VDDA	Power	Analog Power Supply for PLLs and XTAL Oscillators	
92	VSSA	Ground	Analog GND for PLLs and XTAL Oscillators	

1. These pin numbers have multiplexed functions.
2. Signals preceded by 'n' are Active LOW.
3. Immediately after reset, pin 144 can be programmed to function as INT5, DREQ1 or both. Software should avoid enabling both of these functions simultaneously. Pin 144 can also be programmed to function as nWAIT, rendering the INT5/DREQ1 choice unavailable.

NUMERICAL PIN LIST

Table 2. LH79520 Numerical Pin List

PIN NO.	FUNCTION AT RESET	FUNCTION 2	FUNCTION 3	TYPE ⁵	OUTPUT DRIVE ⁷	NOTES
1	nTSTA			Input	None	1
2	A25			Output	8 mA	
3	A24			Output	8 mA	
4	A23			Output	8 mA	
5	A22			Output	8 mA	
6	A21			Output	8 mA	
7	A20			Output	8 mA	
8	VDD			Power	None	
9	A19			Output	8 mA	
10	A18			Output	8 mA	
11	A17			Output	8 mA	
12	A16			Output	8 mA	
13	VSS			Ground	None	
14	A15			Output	8 mA	
15	A14			Output	8 mA	
16	A13			Output	8 mA	
17	A12			Output	8 mA	
18	VDD			Power	None	
19	A11			Output	8 mA	
20	A10			Output	8 mA	
21	A9			Output	8 mA	
22	A8			Output	8 mA	
23	VSS			Ground	None	
24	A7			Output	8 mA	
25	A6			Output	8 mA	
26	A5			Output	8 mA	
27	A4			Output	8 mA	
28	VDD			Power	None	
29	A3			Output	8 mA	
30	A2			Output	8 mA	
31	A1			Output	8 mA	
32	A0			Output	8 mA	
33	VSS			Ground	None	
34	PH7	nBLE3		I/O	8 mA	
35	PH6	nBLE2		I/O	8 mA	
36	nBLE1			Output	8 mA	
37	nBLE0			Output	8 mA	
38	nOE			Output	8 mA	

Table 2. LH79520 Numerical Pin List (Cont'd)

PIN NO.	FUNCTION AT RESET	FUNCTION 2	FUNCTION 3	TYPE ⁵	OUTPUT DRIVE ⁷	NOTES
39	nWE			Output	8 mA	
40	VDDC			Power	None	
41	PH5	nCS6		I/O	8 mA	
42	PH4	nCS5		I/O	8 mA	
43	PH3	nCS4		I/O	8 mA	
44	PH2	nCS3		I/O	8 mA	
45	VSSC			Ground	None	
46	nCS2			Output	8 mA	
47	nCS1			Output	8 mA	
48	nCS0			Output	8 mA	
49	VDD			Power	None	
50	PH1	D31		I/O	8 mA	
51	PH0	D30		I/O	8 mA	
52	PG7	D29		I/O	8 mA	
53	PG6	D28		I/O	8 mA	
54	PG5	D27		I/O	8 mA	
55	VSS			Ground	None	
56	PG4	D26		I/O	8 mA	
57	PG3	D25		I/O	8 mA	
58	PG2	D24		I/O	8 mA	
59	PG1	D23		I/O	8 mA	
60	PG0	D22		I/O	8 mA	
61	PF7	D21		I/O	8 mA	
62	PF6	D20		I/O	8 mA	
63	PF5	D19		I/O	8 mA	
64	VDD			Power	None	
65	PF4	D18		I/O	8 mA	
66	PF3	D17		I/O	8 mA	
67	PF2	D16		I/O	8 mA	
68	D15			I/O	8 mA	
69	D14			I/O	8 mA	
70	VSS			Ground	None	
71	D13			I/O	8 mA	
72	D12			I/O	8 mA	
73	D11			I/O	8 mA	
74	D10			I/O	8 mA	
75	VDDC			Power	None	
76	D9			I/O	8 mA	
77	D8			I/O	8 mA	

Table 2. LH79520 Numerical Pin List (Cont'd)

PIN NO.	FUNCTION AT RESET	FUNCTION 2	FUNCTION 3	TYPE ⁵	OUTPUT DRIVE ⁷	NOTES
78	D7			I/O	8 mA	
79	D6			I/O	8 mA	
80	VSS			Ground	None	
81	D5			I/O	8 mA	
82	D4			I/O	8 mA	
83	D3			I/O	8 mA	
84	D2			I/O	8 mA	
85	VDD			Power	None	
86	D1			I/O	8 mA	
87	D0			I/O	8 mA	
88	CLKINSEL			Input	None	2
89	XTAL32IN			Input	None	8
90	XTAL32OUT			Output		3
91	VDDA			Power	None	
92	VSSA			Ground	None	
93	XTALIN			Input	None	8
94	XTALOUT			Output		3
95	VDDC			Power	None	
96	nRESETIN			Input	None	1, 4
97	nRESETOUT			Output	4 mA	
98	CLKIN	UARTCLK		Input	None	
99	PF1	CLKEN		I/O	2 mA	
100	VDD			Power	None	
101	PF0	SDCLK		I/O	8 mA	
102	PE7	SDCKE		I/O	8 mA	
103	VSS			Ground	None	
104	PE6	nDCS1		I/O	8 mA	
105	PE5	nDCS0		I/O	8 mA	
106	PE4	nSDWE		I/O	8 mA	
107	nRAS			Output	8 mA	
108	nCAS			Output	8 mA	
109	PE3		DQM3	I/O	8 mA	
110	PE2		DQM2	I/O	8 mA	
111	PE1		DQM1	I/O	8 mA	
112	PE0		DQM0	I/O	8 mA	
113	VDDC			Power	None	
114	INT7	LCDVD11		I/O	8 mA	4
115	INT6	LCDVD10		I/O	8 mA	4
116	PD7	LCDVD9		I/O	8 mA	

Table 2. LH79520 Numerical Pin List (Cont'd)

PIN NO.	FUNCTION AT RESET	FUNCTION 2	FUNCTION 3	TYPE ⁵	OUTPUT DRIVE ⁷	NOTES
117	PD6	LCDVD8		I/O	8 mA	
118	PD5	LCDVD7		I/O	8 mA	
119	PD4	LCDVD6	LCDPS	I/O	8 mA	
120	VSSC			Ground	None	
121	PD3	LCDVD5		I/O	8 mA	
122	PD2	LCDVD4		I/O	8 mA	
123	PD1	LCDVD3		I/O	8 mA	
124	PD0	LCDVD2		I/O	8 mA	
125	VDD			Power	None	
126	LCDVD1			Output	8 mA	
127	LCDVD0			Output	8 mA	
128	VSS			Ground	None	
129	PC7	LCDFP	LCDSPL	I/O	8 mA	
130	PC6	LCDVD17		I/O	8 mA	
131	PC5	LCDLP		I/O	8 mA	
132	PC4	LCDVD16		I/O	8 mA	
133	PC3	LCDDCLK		I/O	8 mA	
134	PC2	LCDDCLKIN		I/O	2 mA	
135	PC1	LCDVDDEN	LCDCLS	I/O	8 mA	
136	VDDC			Power	None	
137	PC0	LCDENAB	LCDSPL	I/O	8 mA	
138	VSSC			Ground	None	
139	PB7	LCDVD15	LCDDSPLEN	I/O	8 mA	
140	PB6	LCDVD14		I/O	8 mA	
141	PB5	LCDVD13		I/O	8 mA	
142	PB4	LCDVD12	LCDREV	I/O	8 mA	
143	VDD			Power	None	
144	INT5/DREQ1	nWAIT		Input	None	4, 6
145	CTOUT1B	DACK1		Output	4 mA	
146	PB3	DREQ0		I/O	2 mA	4
147	PB2	nDACK0		I/O	4 mA	
148	PB1	DEOT0		I/O	4 mA	
149	VSS			Ground	None	
150	INT4	PWM0		I/O	4 mA	4
151	INT3	PWMSYNC0		Input	None	4
152	PB0	INT2		I/O	2 mA	4
153	PA7	INT1		I/O	2 mA	4
154	VDDC			Power	None	
155	PA6	INT0		I/O	2 mA	4

Table 2. LH79520 Numerical Pin List (Cont'd)

PIN NO.	FUNCTION AT RESET	FUNCTION 2	FUNCTION 3	TYPE ⁵	OUTPUT DRIVE ⁷	NOTES
156	PA5	CLKOUT		I/O	8 mA	
157	PWM1	DEOT1		Output	4 mA	
158	VSSC			Ground	None	
159	PA4	UARTTX1		I/O	4 mA	
160	PA3	UARTRX1		I/O	2 mA	4
161	VDD			Power	None	
162	UARTIRTX0	UARTTX0		Output	4 mA	
163	UARTIRRX0	UARTRX0		Input	None	4
164	PA2	SSPFRM		I/O	4 mA	
165	PA1	SSPCLK		I/O	4 mA	
166	PA0	SSPEN		I/O	4 mA	
167	SSPTX	UARTTX2		Output	4 mA	
168	VSS			Ground	None	
169	SSPRX	UARTRX2		Input	None	4
170	TMS			Input	None	1, 4
171	TDO			Output	4 mA	
172	TDI			Input	None	1, 4
173	TCLK			Input	None	
174	nTRST			Input	None	1, 4
175	TEST1			Input	None	2
176	TEST2			Input	None	2

NOTES:

1. Input with internal pull-up.
2. Input with internal pull-down.
3. Output is for crystal oscillator only, no drive capability.
4. Input with Schmitt Trigger.
5. I/O = Input/Output.
6. Software should avoid enabling the INT5 and DREQ1 functions simultaneously.
7. Output Drive Values shown are MAX. See 'DC Specifications'.
8. Crystal Oscillator Inputs should be driven to a maximum of $1.8\text{ V} \pm 10\%$.

Table 3. LCD Data Multiplexing

PIN NO.	LCD DATA SIGNAL	STN						ALL TFT: 5:5:5+1	ALL TFT: 5:6:5	ALL TFT: PALETTE DATA OR 6-BIT DIRECT
		MONO 4-BIT		MONO 8-BIT		COLOR				
		SINGLE PANEL	DUAL PANEL	SINGLE PANEL	DUAL PANEL	SINGLE PANEL	DUAL PANEL			
130	LCDVD17							BLUE4	BLUE3	BIT 14
132	LCDVD16							BLUE3	BLUE2	BIT 13
139	LCDVD15				MLSTN7		CLSTN7	BLUE2	BLUE1	BIT 12
140	LCDVD14				MLSTN6		CLSTN6	BLUE1	BLUE0	BIT 11
141	LCDVD13				MLSTN5		CLSTN5	BLUE0	GREEN5	BIT 10
142	LCDVD12				MLSTN4		CLSTN4			
114	LCDVD11		MLSTN3		MLSTN3		CLSTN3	GREEN4	GREEN4	BIT 9
115	LCDVD10		MLSTN2		MLSTN2		CLSTN2	GREEN3	GREEN3	BIT 8
116	LCDVD9		MLSTN1		MLSTN1		CLSTN1	GREEN2	GREEN2	BIT 7
117	LCDVD8		MLSTN0		MLSTN0		CLSTN0	GREEN1	GREEN1	BIT 6
118	LCDVD7			MUSTN7	MUSTN7	CUSTN7	CUSTN7	GREEN0	GREEN0	BIT 5
119	LCDVD6			MUSTN6	MUSTN6	CUSTN6	CUSTN6			
121	LCDVD5			MUSTN5	MUSTN5	CUSTN5	CUSTN5	RED4	RED4	BIT 4
122	LCDVD4			MUSTN4	MUSTN4	CUSTN4	CUSTN4	RED3	RED3	BIT 3
123	LCDVD3	MUSTN3	MUSTN3	MUSTN3	MUSTN3	CUSTN3	CUSTN3	RED2	RED2	BIT 2
124	LCDVD2	MUSTN2	MUSTN2	MUSTN2	MUSTN2	CUSTN2	CUSTN2	RED1	RED1	BIT 1
126	LCDVD1	MUSTN1	MUSTN1	MUSTN1	MUSTN1	CUSTN1	CUSTN1	RED0	RED0	BIT 0
127	LCDVD0	MUSTN0	MUSTN0	MUSTN0	MUSTN0	CUSTN0	CUSTN0	Intensity ⁶	BLUE4	BIT 15

NOTES:

1. The Intensity bit is identically generated for all three colors.
2. MUSTN = Monochrome Upper data bit for STN panel.
3. MLSTN = Monochrome Lower data bit for STN panel.
4. CUSTN = Color Upper data bit for STN panel.
5. CLSTN = Color Lower data bit for STN panel.
6. Connect to the LSB of the Red, Green, and Blue inputs of a 6:6:6 panel.
7. Recommended hookups for TFT 5:5:5 + Intensity and 5:6:5 are shown.
This wiring requires the BGR bit in the LCDControl Register to be 0.

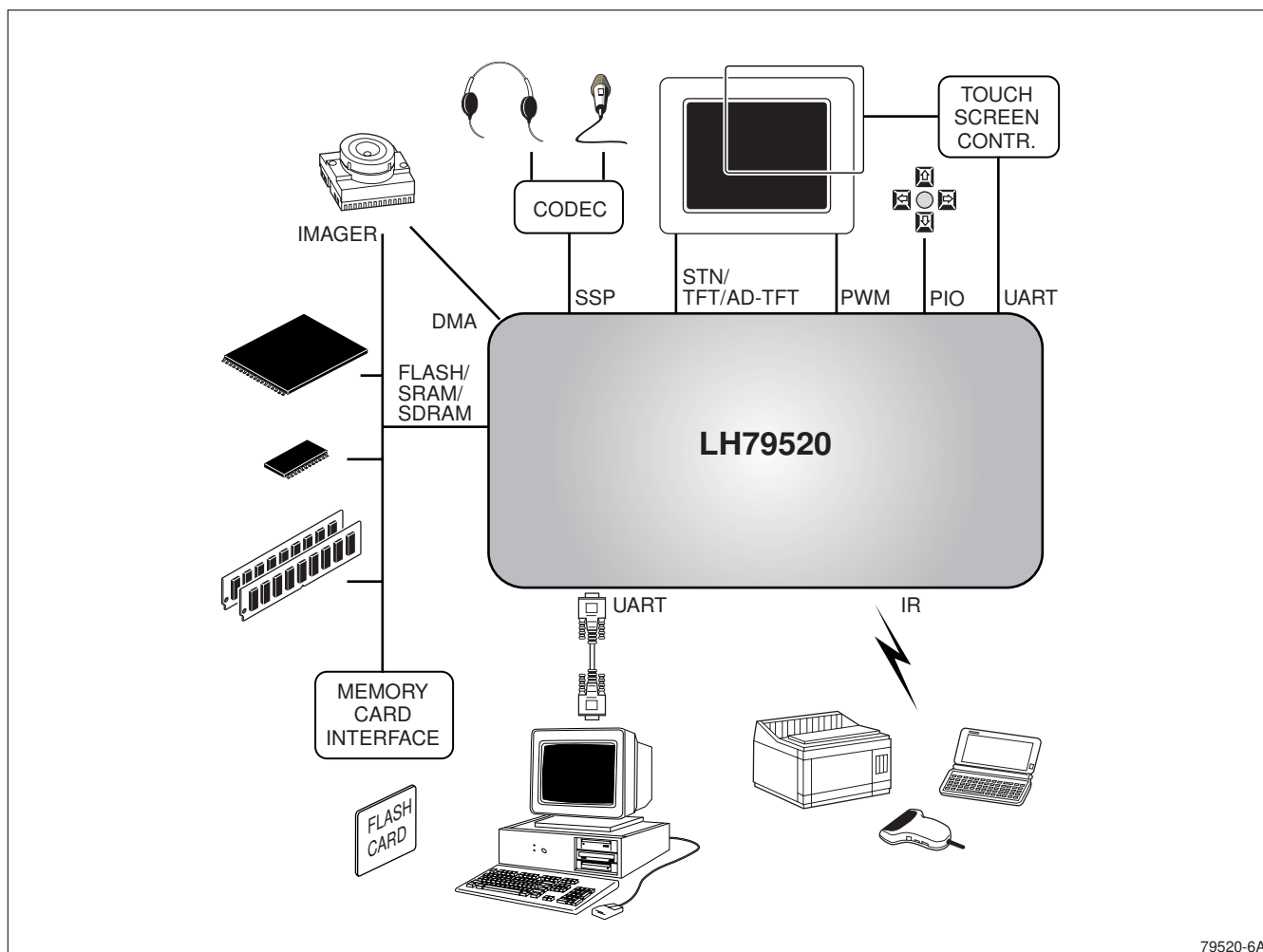

79520-6A

Figure 3. LH79520 Application Diagram Example

SYSTEM DESCRIPTIONS

ARM720T Processor

The LH79520 microcontroller features the ARM720T cached core with an Advanced High-Performance Bus (AHB) interface. The ARM720T features:

- 32-bit ARM7TDMI™ RISC Core
- 8KB Cache
- MMU (Windows CE enabled)

The processor is a member of the ARM7T family of processors. For more information, see the ARM document, 'ARM720T (Rev 3) Technical Reference Manual', available on Sharp's website at www.sharpsma.com.

The LH79520 MMU provides a means to map Physical Memory (PA) addresses to virtual memory addresses. This allows physical memory, which is con-

strained by hardware to specific addresses, to be reorganized at addresses identified by the user. These user identified locations are called Virtual Addresses (VA). When the MMU is enabled, Code and Data must be built, loaded, and executed using Virtual Addresses which the MMU translates to Physical Addresses. In addition, the user may implement a memory protection scheme by using the features of the MMU. Address translation and memory protection services provided by the MMU are controlled by the user. The MMU is directly controlled through the System Control Coprocessor, Coprocessor 15 (CP15). The MMU is indirectly controlled by a Translation Table (TT) and Page Tables (PT) prepared by the user and established using a portion of physical memory dedicated by the user to storing the TT and PT's.

Memory Architecture

An integrated SDRAM Controller and Static Memory Controller provide a glueless interface to external SDRAM, Flash, SRAM, ROM, and burst ROM. Three remap options for the physical memory are selectable by software, as shown in Figures 4, 5, and 6. Memory is exclusively Little Endian.

SDRAM CONTROLLER

The SDRAM Controller provides the interface between the internal bus and external (off-chip) SDRAM memory devices (Figure 2).

The SDRAM Controller provides the following features:

- Two independently controlled chip selects.
- Transfers data between the controller and SDRAM in quad-word bursts.
- Supports both 32-bit and 16-bit SDRAM.
- Supports 2K, 4K, and 8K row address memory parts, i.e. typical 256M, 128M, 64M, and 16M parts, with 8, 16, or 32 DQ bits per device.
- Two reset domains allow SDRAM contents to be preserved over a soft reset.

STATIC MEMORY CONTROLLER (SMC)

The SMC provides the interface between the internal bus and external (off-chip) memory devices.

The LH79520 boots from 16-bit memory. The SMC address space is divided into eight memory banks of 64MB each. The SMC supports:

- Static Memory-mapped Devices including RAM, ROM, Flash, and Burst ROM
- Asynchronous Operations:
 - Page Mode Reads for non-clocked memory
 - Burst Mode Reads for burst mode ROM
- 8-, 16-, and 32-bit wide external memory data paths
- Independent configuration for up to eight memory banks, each up to 64MB
- Programmable Parameters:
 - WAIT States (up to 32)
 - Bus Turnaround Cycles (1 to 16)
 - Initial and Subsequent Burst Read WAIT State for Burst ROM Devices.

The Static Memory Controller (SMC) also supports an nWAIT input that can be used by an external device to vary the wait time.

DMA Controller

The DMA Controller provides support for DMA-capable peripherals. The LCD controller uses its own DMA port, connecting directly to memory for retrieving display data.

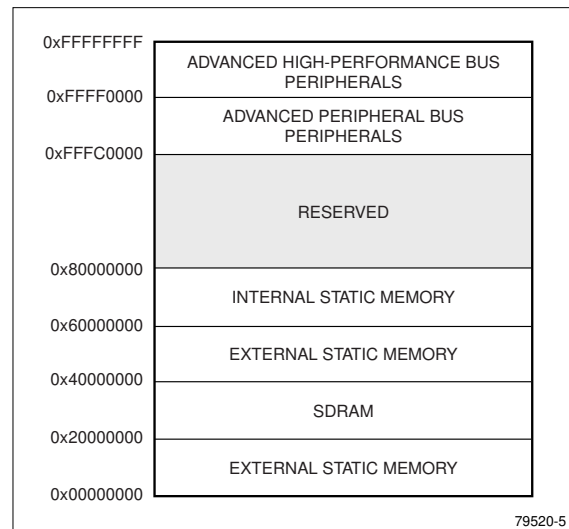

Figure 4. Memory Remap '00' and '11'

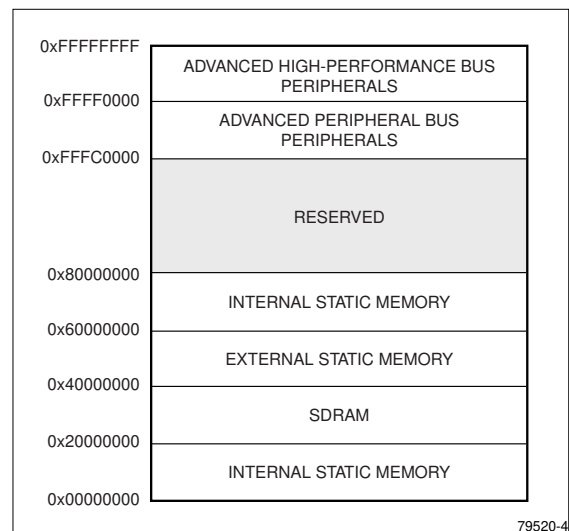

Figure 5. Memory Remap '10'

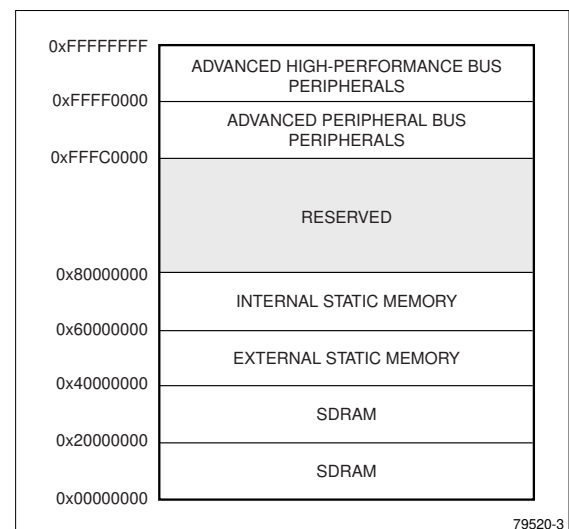

Figure 6. Memory Remap '01'

- Simultaneous servicing of up to 4 data streams
- Three transfer modes are supported:
 - Memory to Memory
 - Peripheral to Memory
 - Memory to Peripheral
- Identical source and destination capabilities
- Transfer Size Programmable (Byte, Half-word, Word)
- Burst Size Programmable
- Address Increment or Address Freeze
- Transfer Error indication for each stream via an interrupt
- 16-word FIFO array with pack and unpack logic

Handles all combinations of byte, half-word or word transfers from input to output.

Color LCD Controller (CLCDC)

The CLCDC provides all the necessary control and drive signals to interface directly with a variety of color and monochrome LCD panels.

- Supports single and dual scan color and monochrome Super Twisted Nematic (STN) displays with 4- or 8-bit interfaces
- Supports Thin Film Transistor (TFT) color displays
- Programmable resolution up to 800 × 600
 - 800 × 600 (16-bit color can only be supported at ≤ 65 Hz refresh rates with 800 × 600 resolution).
- 15 gray-level mono, 3,375 color STN, and 64 k color TFT support
- 1, 2, or 4 bits-per-pixel (BPP) for monochrome STN
- 1-, 2-, 4-, or 8-BPP palettized color displays for color STN and TFT
- True-color non-palettized, for color STN and TFT
- Programmable timing for different display panels
- 256-entry, 16-bit palette fast-access RAM
- Frame, line and pixel clock signals
- AC bias signal for STN or data enable signal for TFT panels
- Patented grayscale algorithm
- Interrupt Generation Events
- Dual 16-deep programmable 32-bit wide FIFOs for buffering incoming data.

ADVANCED LCD INTERFACE

The Advanced LCD Interface peripheral allows for direct connection to ultra-thin panels that do not include a timing ASIC. It converts TFT signals from the Color LCD controller to provide the proper signals, timing and levels for direct connection to a panel's Row and Column drivers for AD-TFT, HR-TFT, or any technology of panel that allows for a connection of this type. The

Advanced LCD Interface peripheral also provides a bypass mode that allows the LH79520 to interface to the built-in timing ASIC in standard TFT and STN panels.

Synchronous Serial Port (SSP)

The SSP is a master-only interface for synchronous serial communication with slave peripheral devices that support protocols for Motorola SPI, National Semiconductor MICROWIRE, or Texas Instruments Synchronous Serial Interface.

- Master-only operation
- Programmable clock rate
- Separate transmit FIFO and receive FIFO buffers, 16 bits wide, 8 locations deep
- DMA for transmit and receive
- Programmable interface protocols: Motorola SPI, National Semiconductor MICROWIRE, or Texas Instruments Synchronous Serial Port
- Programmable data frame size from 4 to 16 bits
- Independent masking of transmit FIFO, receive FIFO and receive overrun interrupts
- Available internal loopback test mode.

Universal Asynchronous Receiver Transmitter (UART)

The LH79520 incorporates three UARTs.

- Programmable use of UART0 or IrDA SIR input/output
- Separate 16-byte transmit and receive FIFOs to reduce CPU interrupts
- Programmable FIFO disabling for 1-byte depth
- Programmable baud rate generator
- Independent masking of transmit FIFO, receive FIFO, receive timeout and modem status interrupts
- False start bit detection
- Line Break generation and detection
- Fully-programmable serial interface characteristics:
 - 5-, 6-, 7-, or 8-bit data word length
 - Even-, odd- or no-parity bit generation and detection
 - 1 or 2 stop bit generation
- IrDA SIR Encode/Decode block, providing:
 - Programmable use of IrDA SIR or UART0 input/output
 - Supports data rates up to 115.2 Kbps half-duplex
 - Programmable internal clock generator, allowing division of the Reference clock in increments of 1 to 512 for low-power mode bit durations.

VARIATIONS FROM THE 16C550 UART

The UART varies from the industry-standard 16C550 UART device in six ways:

- Receive FIFO trigger levels are fixed at 8 bytes
- Receive errors are stored in the FIFO, and do not generate an interrupt.
- The internal register map address space and each register's bit function differ.

The following 16C550 UART features are not supported:

- 1.5 stop bits (1 or 2 stop bits only are supported)
- The forcing stick parity function
- Independent receive clock.

Pulse Width Modulator (PWM)

- Two independent output channels with separate input clocks
- Up to 16-bit resolution
- Programmable synchronous mode support
 - Allows external input to start PWM
- Programmable pulse width (duty cycle), interval (frequency), and polarity
 - Static programming: PWM is stopped
 - Dynamic programming: PWM is running
 - Updates duty cycle, frequency, and polarity at the end of a PWM cycle
 - Wide programming range.

Vectored Interrupt Controller

The Vectored Interrupt Controller combines the interrupt request signals from 20 internal and eight external interrupt sources and applies them, after masking and prioritization, to the IRQ and FIQ interrupt inputs of the ARM7TDMI processor core.

The Interrupt Controller incorporates a hardware interrupt vector logic with programmable priority for up to 16 interrupt sources. This logic reduces the interrupt response time for IRQ type interrupts compared to solutions using software polling to determine the highest priority interrupt source. This significantly improves the real-time capabilities of the LH79520 in embedded control applications.

- 20 internal and eight external interrupt sources
 - Individually maskable
 - Status accessible for software polling
- IRQ interrupt vector logic for up to 16 channels with programmable priorities
- All of the interrupt channels, with the exception of the Watchdog Timer interrupt, can be programmed to generate:

- FIQ interrupt request
- Non-vectored IRQ interrupt request (software to poll IRQ source)
- Vectored IRQ interrupt request (up to 16 channels total)
- The Watchdog timer can only generate FIQ interrupt requests
- External interrupt inputs programmable
 - Edge triggered or level triggered
 - Rising edge/active HIGH or falling edge/active LOW

The 28 interrupt channels are shown in Table 4.

Table 4. Interrupt Channels

CHANNEL	INTERRUPT SOURCE
0	External Interrupt 0
1	External Interrupt 1
2	External Interrupt 2
3	External Interrupt 3
4	External Interrupt 4
5	External Interrupt 5
6	External Interrupt 6
7	External Interrupt 7
8	Spare Internal Interrupt 0
9	COMRX (used for debug)
10	COMTX (used for debug)
11	SSP RX time-out interrupt SSPRXTO
12	CLCD Combined Interrupt
13	SSP SSPTXINTR
14	SSP SSPRXINTR
15	SSP SSPRORINTR
16	SSP SSPINTR
17	Counter/Timer0
18	Counter/Timer1
19	Counter/Timer2
20	Counter/Timer3
21	UART ch0 Rx
22	UART ch0 Tx
23	UART ch0
24	UART ch1
25	UART ch2
26	DMA Combined
27-29	Unused
30	RTC_ALARM
31	WDT

Reset, Clock, and Power Controller (RCPC)

The RCPC generates the various clock signals for the operation of the LH79520 and provides for an orderly start-up after power-on and during a wake-up from one of the power saving operating modes. The RCPC allows the software to individually select the frequency of the various on-chip clock signals as required to operate the chip in the most power-efficient mode. It features:

- 14.7456 MHz crystal oscillator and PLL for on-chip Clock generation
- External Clock input if on-chip oscillator and PLL are not used
- 32.768 kHz crystal oscillator generating 1 Hz clock for Real Time Clock
- Individually controlled clocks for peripherals and CPU
- Clock source for UARTs is selectable between 14.7456 MHz crystal oscillator and external clock source
- Programmable clock prescalers for UARTs and PWMs
- Five global power control modes are available:
 - Active
 - Standby
 - Sleep
 - Stop1
 - Stop2
- CPU and Bus clock frequency can be changed on the fly
- Selectable clock output
- Hardware reset (nRESETIN) and software reset.

Table 5. Clock and Enable States for Different Power Modes (Using On-chip Oscillator and PLL)

FUNCTION	ACTIVE	STANDBY	SLEEP	STOP1	STOP2
14.7456 MHz Oscillator	ON	ON	ON	ON	OFF
PLL	ON	ON	ON	OFF	OFF
Peripheral Clock	ON	ON	OFF	OFF	OFF
CPU Clock	ON	OFF	OFF	OFF	OFF

Real Time Clock

The RTC can provide a basic alarm function or long time base counter. This is achieved by generating an interrupt signal after counting for a programmed number of cycles of RTC input. Counting in one-second intervals is achieved by the use of a 1 Hz clock input to the RTC.

The features of the RTC are:

- 32-bit up counter with programmable load
- Programmable 32-bit match compare register
- Software maskable interrupt when counter and compare registers are identical.

RTC input clock sources:

- PLL clock
- 32.768 kHz clock
- 1 Hz clock (default).

Watchdog Timer

The Watchdog Timer provides hardware protection against malfunctions. It is a programmable timer to be reset by software at regular intervals. Failure to reset the timer will cause a FIQ interrupt. Failure to service the FIQ interrupt will then generate a System Reset. The features of the Watchdog Timer are:

- Driven by the bus clock
- 16 programmable time-out periods: 2^{16} through 2^{31} clock cycles
- Generates a system reset (resets LH79520) or a FIQ Interrupt whenever a time-out period is reached
- Software enable, lockout, and counter-reset mechanisms add security against inadvertent writes
- Protection mechanism guards against interrupt-service failure:
 - The first WDT time-out triggers FIQ and asserts nWDFIQ status flag
 - If FIQ service routine fails to clear nWDFIQ, then the next WDT time-out triggers a soft reset.

Timer

The LH79520 incorporates two Timer modules, each comprising two 16-bit independently programmable timers. This gives a total of four independent timers.

- Each timer has two operating modes:
 - Free-running mode: After reaching 0x0000 the timer wraps around to 0xFFFF and generates an interrupt request. It continues to count down from 0xFFFF.
 - Periodic timer mode: After reaching 0x0000 the timer is automatically reloaded with its programmed value and generates an interrupt request. It continues to count down from the loaded value.
- Each timer contains a programmable pre-scaler:
 - Bus clock divided by 1, 16, or 256
- Timers can be cascaded to achieve longer timing periods
- Carry-out of higher-order timer provides clock signal for next lower order timer
- Possible timing ranges:
 - 2^{15} (single timer)
 - 2^{31} (two timers cascaded)
 - 2^{47} (three timers cascaded)
 - 2^{63} (four timers cascaded)
- Output signal of lowest order timer is externally available as CTOUT1B signal.

Input/Output Configuration System

The registers provided by the IOCON System allow the user to directly control the pin multiplexing of the device; by setting or clearing bits in a set of registers, the user can configure the LH79520 for peripheral devices.

General Purpose Input/Output (GPIO)

The LH79520 provides up to 64 bits of programmable input/output. These eight 8-bit ports are Ports A through H, and are multiplexed with other signals.

- Individually programmable input/output pins
- All I/O ports default to Input on power-up.

ELECTRICAL SPECIFICATIONS**Absolute Maximum Ratings**

PARAMETER	SYMBOL	RATING	UNIT
DC Core Supply Voltage	VDDC	-0.3 to 2.4	V
DC I/O Supply Voltage	VDD	-0.3 to 4.6	V
DC Analog Supply Voltage	VDDA	-0.3 to 2.4	V
Storage Temperature	TSTG	-55 to +125	°C

NOTE: These stress ratings are only for transient conditions. Operation at or beyond absolute maximum rating conditions may affect reliability and cause permanent damage to the device.

Recommended Operating Conditions

PARAMETER	MINIMUM	TYPICAL	MAXIMUM
DC Core Supply Voltage (VDDC)	1.62 V	1.8 V	1.98 V
DC I/O Supply Voltage (VDD)	3.0 V	3.3 V	3.6 V
DC Analog Supply Voltage (VDDA)	1.62 V	1.8 V	1.98 V
Clock Frequency*	10 MHz		77.4144 MHz
Commercial Operating Temperature	0°C	25°C	+70°C
Industrial Operating Temperature	-40°C	25°C	+85°C

NOTE: *Using 14.7456 MHz Input Crystal and On-Chip PLL. Functional to DC when using external clock.

DC/AC SPECIFICATIONS (COMMERCIAL)

Unless otherwise noted, all data provided under commercial DC specifications are based on 0°C to +70°C, VDDC = 1.62 V to 1.98 V, VDD = 3.0 V to 3.6 V, VDDA = 1.62 V to 1.98 V.

DC Specifications (Commercial)

SYMBOL	PARAMETER	MIN.	TYP.	MAX.	UNIT	CONDITIONS	NOTES
VIH	CMOS input HIGH voltage	2.0		5.5	V		
VIL	CMOS input LOW voltage			0.8	V		
VIT+	Positive Input threshold voltage (Schmitt trigger pins)		1.60		V		1
VIT-	Negative Input threshold voltage (Schmitt trigger pins)		1.20		V		
VHYST	Schmitt trigger hysteresis		0.40		V	VIT+ – VIT-	
VOH	CMOS output HIGH voltage	2.6			V	IOH = -50 μ A	1
	Output drive (2 mA type)	2.6			V	IOH = -2 mA	
	Output drive (4 mA type)	2.6			V	IOH = -4 mA	
	Output drive (8 mA type)	2.6			V	IOH = -8 mA	
VOL	CMOS output LOW voltage			0.4	V	IOL = 50 μ A	1
	Output drive (2 mA type)			0.4	V	IOL = 2 mA	
	Output drive (4 mA type)			0.4	V	IOL = 4 mA	
	Output drive (8 mA type)			0.4	V	IOL = 8 mA	
XTAL32IN	External Clock Input	1.62	1.8	1.98	V		
XTALIN	External Clock Input	1.62	1.8	1.98	V		
IIN	Input leakage current	-10		10	μ A	VIN = VDD or GND	
IOZ	Output tri-state leakage current	-10		10	μ A	VOUT = VDD or GND	
IACTIVE	Active current		43.5	55	mA		2
ISTANDBY	Standby current		27.5	35	mA		2, 3
ISLEEP	Sleep current		3.9	5.5	mA		
ISTOP1	Stop1 current		500		μ A		
ISTOP2	Stop2 current (RTC ON)		34		μ A		
ISTOP2	Stop2 current (RTC OFF)		18		μ A		
CIN	Input Capacitance			4	pF		
COUT	Output Capacitance			4	pF		

NOTES:

1. Table 2 details each pin's buffer type.
2. Running Typical Application over operating range.
3. Current measured with CPU stopped and all peripherals enabled.

AC Test Conditions

PARAMETER	RATING	UNIT
Supply Voltage (VDD)	3.0 to 3.6	V
Core Voltage (VDDC)	1.62 to 1.98	V
Input Pulse Levels	VSS to VDD	V
Input Rise and Fall Times	2	ns
Input and Output Timing Ref. Levels	VDD/2	V

AC Specifications

All signals described in Table 6 relate to transitions after a reference clock signal. The illustration in Figure 7 represents all cases of these sets of measurement parameters; except for the Asynchronous Memory Interface — which are referenced to Address Valid.

The reference clock signals in this design are:

- HCLK, the System Bus clock
- PCLK, the Peripheral Bus clock (locked to HCLK in the LH79520)
- SSPCLK, the Synchronous Serial Interface clock
- UARTCLK, the UART Interface clock
- LCDDCLK, the LCD Data clock from the LCD Controller
- and SDCLK, the SDRAM clock.

All signal transitions are measured from the 50% point of the clock to the 50% point of the signal. See Figure 7.

For outputs from the LH79520, t_{OVXXX} (e.g. t_{OVA}) represents the amount of time for the output to become valid from the rising edge of the reference clock signal. Maximum requirements for t_{OVXXX} are shown in Table 6.

The signal t_{OHXXX} (e.g. t_{OHA}) represents the amount of time the output will be held valid from the rising edge of the reference clock signal. Minimum requirements for t_{OHXXX} are listed in Table 6.

For Inputs, t_{ISXXX} (e.g. t_{ISD}) represents the amount of time the input signal must be valid before the rising edge of the clock signal. Minimum requirements for t_{ISXXX} are shown in Table 6.

The signal t_{IHXXX} (e.g. t_{IHD}) represents the amount of time the output must be held valid from the rising edge of the reference clock signal. Minimum requirements are shown in Table 6.

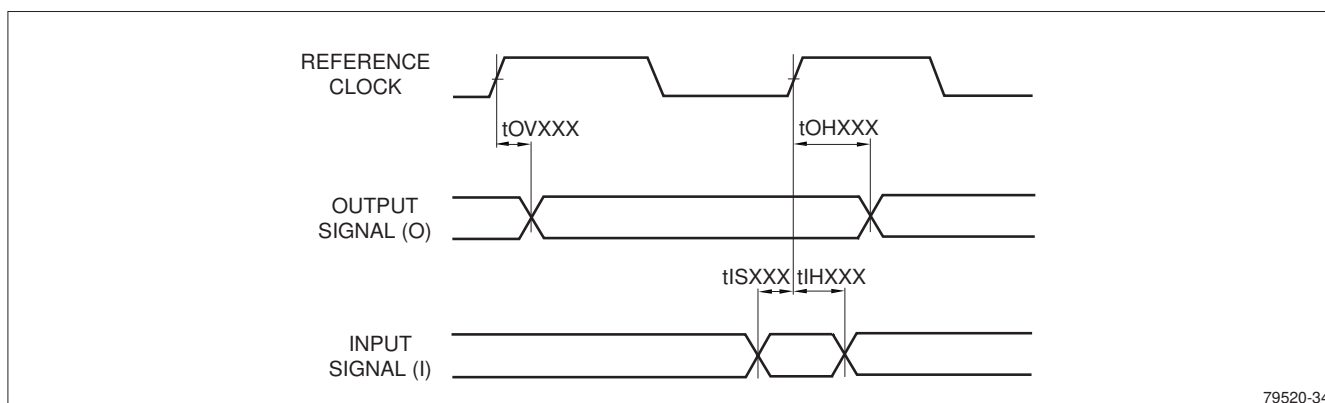

Figure 7. LH79520 Signal Timing

Table 6. AC Signal Characteristics (Commercial)

SIGNAL	TYPE	LOAD	DRIVE	SYMBOL	MIN.	MAX.	DESCRIPTION
ASYNCHRONOUS MEMORY INTERFACE SIGNALS							
D[31:0]	Output	50 pF	8 mA	tOVD		tHCLK + 6 ns	Data Output Valid, following Address Valid
				tOHD	3 × tHCLK - 6 ns		Data Output Invalid, following Address Valid
	Input			tIDD		2 × tHCLK - 18 ns	Data Input Valid, following Address Valid
nCS6 - nCS0	Output	30 pF	8 mA	tOVCS		tHCLK + 6 ns	Chip Select Output Valid, following Address Valid
				tOHCS	3 × tHCLK - 6 ns		Chip Select Output Invalid, following Address Valid
nBLE[3:0]	Output	30 pF	8 mA	tOVBE		tHCLK + 10 ns	Byte Lane Enable Valid, following Address Valid
				tOHBEW	2 × tHCLK - 6 ns		Byte Lane Enable Invalid, following Address Valid; Write Cycle
				tOHBER	3 × tHCLK - 6 ns		Byte Lane Enable Invalid, following Address Valid; Read Cycle
nWE	Output	30 pF	8 mA	tOVWE		tHCLK + 10 ns	Write Enable Valid, following Address Valid
				tOHWE	2 × tHCLK - 6 ns		Write Enable Invalid, following Address Valid
nOE	Output	30 pF	8 mA	tOVOE		tHCLK + 10 ns	Output Enable Valid, following Address Valid
				tOHOE	3 × tHCLK - 6 ns		Output Enable Invalid, following Address Valid
nWAIT	Input			tISWAIT		2 × tHCLK - 18 ns	WAIT Input Valid, following Address Valid
SYNCHRONOUS MEMORY INTERFACE SIGNALS							
A[25:0]	Output	50 pF	8 mA	tOVA		10.5 ns	Address Valid
D[31:0]	Output	50 pF	8 mA	tOVD		11 ns	Output Data Valid
				tOHD	1.2 ns		Output Data Hold
	Input			tISD	5 ns		Input Data Setup
				tIDD	1.5 ns		Input Data Hold
nCAS	Output	50 pF	8 mA	tOVCA		10.5 ns	CAS Valid
				tOHCA	2 ns		CAS Hold
nRAS	Output	50 pF	8 mA	tOVRA		10.5 ns	RAS Valid
				tOHRA	2 ns		RAS Hold
nSDWE	Output	30 pF	8 mA	tOVSDW		10.5 ns	SDWE Write Enable Valid
				tOHSDW	2 ns		SDWE Write Enable Hold
SDCKE	Output	30 pF	8 mA	tOVCO		10.5 ns	SDCKE Clock Enable Valid
				tOHCO	2 ns		SDCKE Clock Enable Hold
DQM[3:0]	Output	30 pF	8 mA	tOVDDQ		10.5 ns	DQM Data Mask Valid
				tOHDDQ	2 ns		DQM Data Mask Hold
nSDCS[1:0]	Output	30 pF	8 mA	tOVSC		10.5 ns	SDCS Data Mask Valid
				tOHSC	2 ns		SDCS Data Mask Hold
SDCLK	Output	30 pF	8 mA	tSDCLK	19.37 ns		SDRAM Clock Period

Table 6. AC Signal Characteristics (Commercial) (Cont'd)

SIGNAL	TYPE	LOAD	DRIVE	SYMBOL	MIN.	MAX.	DESCRIPTION
SYNCHRONOUS SERIAL PORT (SSP)							
SSPFRM	Output	50 pF	2 mA	tOVSSPFRM		14 ns	tOVSSPFRM Output Valid, Referenced to SSPCLK
SSPENB	Output	50 pF	2 mA	tOVSSPENB		14ns	tOVSSPENB Output Valid, Referenced to SSPCLK
SSPTX	Output	50 pF	2 mA	tOVSSPOUT		14ns	SSP Transmit Valid
SSPRX	Input			tISSPIN	17 ns		SSP Receive Setup
INTERRUPTS							
INTR[5:0]	Input						Note 1

NOTES:

1. INTR[5:0] are asynchronous signals. Interrupts must be held Active until serviced in Level Sensitive Mode, and held Active for a minimum of 20 ns in Edge Sensitive Mode.
2. DACK0, nDACK1 and DREQ[1:0] are asynchronous signals. They must be held Active until serviced, for a minimum of 20 ns.