



Chipsmall Limited consists of a professional team with an average of over 10 year of expertise in the distribution of electronic components. Based in Hongkong, we have already established firm and mutual-benefit business relationships with customers from,Europe,America and south Asia,supplying obsolete and hard-to-find components to meet their specific needs.

With the principle of “Quality Parts,Customers Priority,Honest Operation,and Considerate Service”,our business mainly focus on the distribution of electronic components. Line cards we deal with include Microchip,ALPS,ROHM,Xilinx,Pulse,ON,Everlight and Freescale. Main products comprise IC,Modules,Potentiometer,IC Socket,Relay,Connector.Our parts cover such applications as commercial,industrial, and automotives areas.

We are looking forward to setting up business relationship with you and hope to provide you with the best service and solution. Let us make a better world for our industry!



Contact us

Tel: +86-755-8981 8866 Fax: +86-755-8427 6832

Email & Skype: info@chipsmall.com Web: www.chipsmall.com

Address: A1208, Overseas Decoration Building, #122 Zhenhua RD., Futian, Shenzhen, China



Hyper Multi TOPLED® Hyper-Bright LED

LHGB T686

Vorläufige Daten / Preliminary Data

**Abgekündigt nach OS-PD-2005-002 - wird durch
LATB T686 ersetzt werden**
**Obsolete acc. to OS-PD-2005-002 - will be replaced by
LATB T686**



Besondere Merkmale

- **Gehäusertyp:** weißes P-LCC-4 Gehäuse, Kontrasterhöhung durch schwarze Oberfläche (RGB-Displays)
- **Besonderheit des Bauteils:** additive Farbmischung durch unabhängige Ansteuerung aller Chips
- **Wellenlänge:** 645 nm (hyper-rot), 570 nm (grün), 465 nm (blau)
- **Abstrahlwinkel:** Lambertscher Strahler (120°)
- **Technologie:** AlGaAs (hyper-rot), GaP (grün), GaN (blau)
- **optischer Wirkungsgrad:** 3 lm/W (hyper-rot), 2,5 lm/W (grün), 1 lm/W (blau)
- **Gruppierungsparameter:** Lichtstärke
- **Verarbeitungsmethode:** für alle SMT-Bestücktechniken geeignet
- **Lötmethode:** IR Reflow Löten und Wellenlöten (TTW)
- **Vorbehandlung:** nach JEDEC Level 2
- **Gurtung:** 8-mm Gurt mit 8000/Rolle, ø330 mm

Anwendungen

- Anzeigen im Innenbereich (z.B. Laufschritzanzeigen)
- Leuchtdiodenchips getrennt ansteuerbar
- Vollfarbdisplays bzw. RGB-Displays
- Hinterleuchtung (LCD, Schalter, Tasten, Displays, Werbebeleuchtung, Allgemeinbeleuchtung)
- Einkopplung in Lichtleiter
- Für Automobil-Anwendungen nicht geeignet

Features

- **package:** white P-LCC-4 package, higher contrast by a black surface (RGB-Displays)
- **feature of the device:** additive mixture of color stimuli by independent driving of each chip
- **wavelength:** 645 nm (hyper-red), 570 nm (green), 465 nm (blue)
- **viewing angle:** Lambertian Emitter (120°)
- **technology:** AlGaAs (hyper-red), GaP (green), GaN (blue)
- **optical efficiency:** 3 lm/W (hyper-red), 2.5 lm/W (green), 1 lm/W (blue)
- **grouping parameter:** luminous intensity
- **assembly methods:** suitable for all SMT assembly methods
- **soldering methods:** IR reflow soldering and TTW soldering
- **preconditioning:** acc. to JEDEC Level 2
- **taping:** 8 mm tape with 8000/reel, ø330 mm

Applications

- indoor displays (e.g. light writing displays)
- LED chips can be controlled separately
- full color displays, RGB-Displays
- backlighting (LCD, switches, keys, displays, illuminated advertising, general lighting)
- coupling into light guides
- not suitable for automotive applications

Bestellinformation
Ordering Information

Typ Type	Emissions- farbe Color of Emission	Lichtstärke ¹⁾ Seite 19 Luminous Intensity ¹⁾ page 19 $I_F = 10 \text{ mA}$ $I_V \text{ (mcd)}$		
		hyper-red	green	blue
■ LHGB T686	hyper-red green blue	7.1 ...18.0	7.1 ...18.0	4.5 ...11.2

- Abgekündigt nach OS-PD-2005-002 - wird durch LATB T686 ersetzt werden
 Obsolete acc. to OS-PD-2005-002 - will be replaced by LATB T686
 Letzte Bestellung / Last Order: 2005-08-31
 Letzte Lieferung / Last Delivery: 2006-02-28

Bestellinformation
Ordering Information

Typ Type	Bestellnummer Ordering Code
LHGB T686-KL-1+KL-1+JK-1	Q62703Q5771

Anm.: -1 Gesamter Farbbereich (siehe Seite 4)

Note: -1 Total color tolerance range (see page 4)

Grenzwerte
Maximum Ratings

Bezeichnung Parameter	Symbol Symbol	Werte Values			Einheit Unit
		hyper red	green	blue	
Betriebstemperatur Operating temperature range	T_{op}	- 40 ... + 100			°C
Lagertemperatur Storage temperature range	T_{stg}	- 40 ... + 100			°C
Sperrschichttemperatur Junction temperature	T_j	+ 100			°C
Durchlassstrom Forward current ($T_A=25^\circ\text{C}$)	I_F	30	30	20	mA
Stoßstrom Surge current $t_p = 10 \mu\text{s}, D = 0.005, T_A=25^\circ\text{C}$	I_{FM}	500	500	200	mA
Sperrspannung ^{2) Seite 19} Reverse voltage ^{2) page 19} ($T_A=25^\circ\text{C}$)	V_R	5	12	5	V
Leistungsaufnahme Power consumption ($T_A=25^\circ\text{C}$)	P_{tot}	90	95	90	mW
Wärmewiderstand Thermal resistance					
Sperrschicht / Umgebung ^{3) Seite 19} Junction / ambient ^{3) page 19}	1 chip on $R_{th JA}$	480	480	580	K/W
	3 chips on $R_{th JA}$	680	770	820	K/W
Sperrschicht / Löt看 Junction / solder point	1 chip on $R_{th JS}$	260	260	360	K/W
	3 chips on $R_{th JS}$	370	420	510	K/W

Kennwerte
Characteristics

($T_A = 25\text{ °C}$)

Bezeichnung Parameter	Symbol Symbol	Werte Values			Einheit Unit
		hyper red	green	blue	
Wellenlänge des emittierten Lichtes (typ.) Wavelength at peak emission $I_F = 10\text{ mA}$	λ_{peak}	660	572	428	nm
Dominantwellenlänge ^{4) Seite 19} Dominant wavelength ^{4) page 19} $I_F = 10\text{ mA}$	λ_{dom}	645 ± 9	570 ± 6	465 ± 3	nm
Spektrale Bandbreite bei 50 % $I_{\text{rel max}}$ (typ.) Spectral bandwidth at 50 % $I_{\text{rel max}}$ $I_F = 10\text{ mA}$	$\Delta\lambda$	22	25	60	nm
Abstrahlwinkel bei 50 % I_V (Vollwinkel) (typ.) Viewing angle at 50 % I_V	2ϕ	120	120	120	Grad deg.
Durchlassspannung ^{5) Seite 19} (typ.) Forward voltage ^{5) page 19} (max.) $I_F = 10\text{ mA}$	V_F V_F	1.75 2.5	2.0 2.5	3.5 4.1	V V
Sperrstrom (typ.) Reverse current (max.) $V_R = 12\text{ V}$ (green), $V_R = 5\text{ V}$ (hyper-red, blue)	I_R I_R	0.01 10	0.01 10	0.01 10	μA μA
Temperaturkoeffizient von λ_{peak} (typ.) Temperature coefficient of λ_{peak} $I_F = 10\text{ mA}$; $-10\text{ °C} \leq T \leq 100\text{ °C}$	$TC_{\lambda_{\text{peak}}}$	0.28	0.11	0.004	nm/K
Temperaturkoeffizient von λ_{dom} (typ.) Temperature coefficient of λ_{dom} $I_F = 10\text{ mA}$; $-10\text{ °C} \leq T \leq 100\text{ °C}$	$TC_{\lambda_{\text{dom}}}$	0.05	0.07	0.03	nm/K
Temperaturkoeffizient von V_F (typ.) Temperature coefficient of V_F $I_F = 10\text{ mA}$; $-10\text{ °C} \leq T \leq 100\text{ °C}$	TC_V	- 2.5	- 1.4	- 3.1	mV/K
Optischer Wirkungsgrad (typ.) Optical efficiency $I_F = 10\text{ mA}$	η_{opt}	3	2.5	1	lm/W

Helligkeits-Gruppierungsschema
Brightness Groups

Helligkeitsgruppe Brightness Group	Lichtstärke ^{1) Seite 19} Luminous Intensity ^{1) page 19}	Lichtstrom ^{6) Seite 19} Luminous Flux ^{6) page 19}
	I_V (mcd)	Φ_V (lm)
J	4.5 ... 7.1	17 (typ.)
K	7.1 ... 11.2	27 (typ.)
L	11.2 ... 18.0	45 (typ.)

Anm.: Die Standardlieferform von Serientypen beinhaltet eine Familiengruppe. Einzelne Helligkeitsgruppen sind nicht bestellbar.

Note: The standard shipping format for serial types includes a family group. Individual brightness groups cannot be ordered.

Gruppenbezeichnung auf Etikett
Group Name on Label

Beispiel: K-1+L-1+J-1

Example: K-1+L-1+J-1

Helligkeitsgruppe Brightness Group	Wellenlänge (keine Gruppierung) Wavelength (no grouping)	Helligkeitsgruppe Brightness Group	Wellenlänge (keine Gruppierung) Wavelength (no grouping)	Helligkeitsgruppe Brightness Group	Wellenlänge (keine Gruppierung) Wavelength (no grouping)
(hyper-red)	(hyper-red)	(green)	(green)	(blue)	(blue)
K	1	L	1	J	1

Anm.: In einer Verpackungseinheit / Gurt ist immer nur eine Helligkeitsgruppe pro Farbe enthalten.

Note: No packing unit / tape ever contains more than one brightness group per color.

Relative spektrale Emission^{6) Seite 19}

Relative Spectral Emission^{6) page 19}

$V(\lambda)$ = spektrale Augenempfindlichkeit / Standard eye response curve

$I_{rel} = f(\lambda)$; $T_A = 25\text{ °C}$; $I_F = 10\text{ mA}$

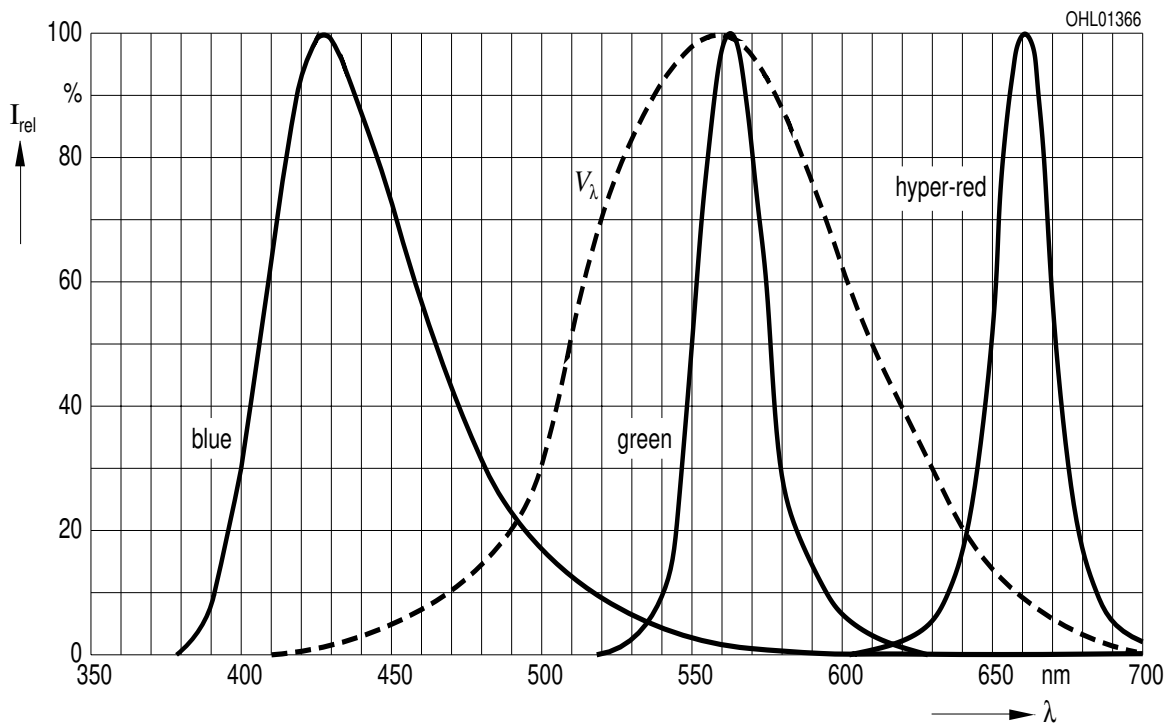

Abstrahlcharakteristik^{6) Seite 19}

Radiation Characteristic^{6) page 19}

$I_{rel} = f(\varphi)$; $T_A = 25\text{ °C}$

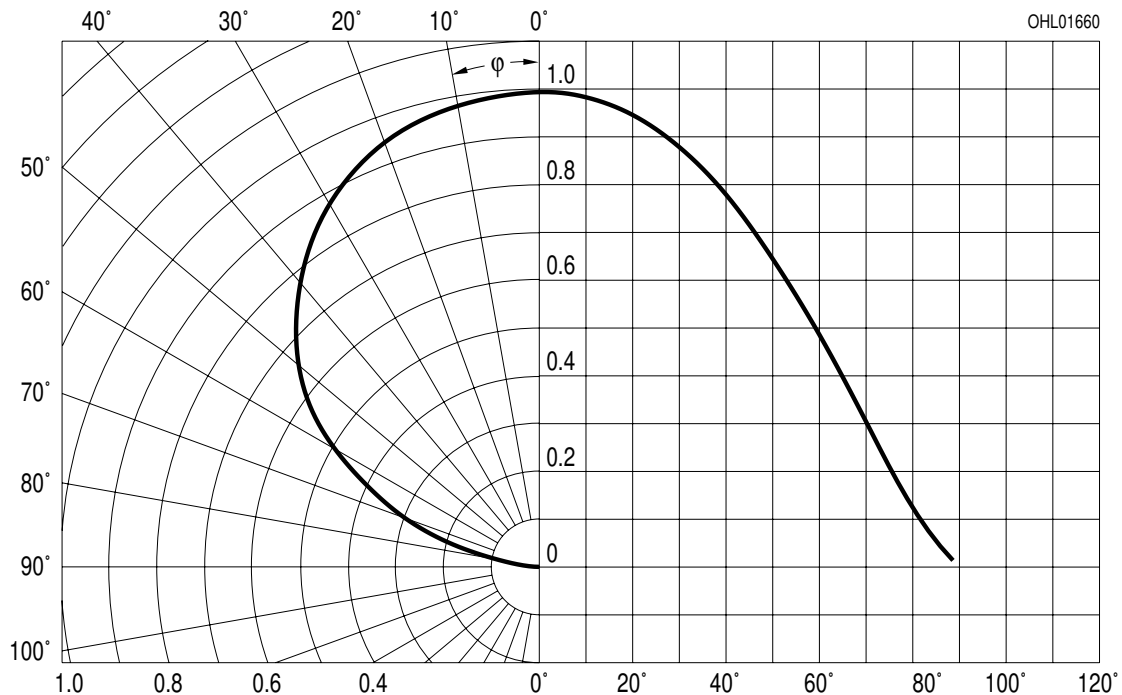

Durchlassstrom^{(6) 7) Seite 19}

Forward Current^{(6) 7) page 19}

$I_F = f(V_F); T_A = 25\text{ °C}$

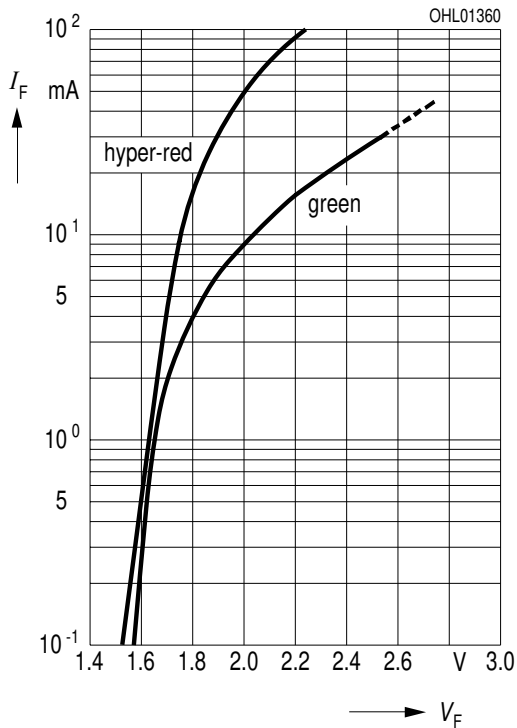

Relative Lichtstärke^{(6) 7) Seite 19}

Relative Luminous Intensity^{(6) 7) page 19}

$I_V/I_{V(10\text{ mA})} = f(I_F); T_A = 25\text{ °C}$

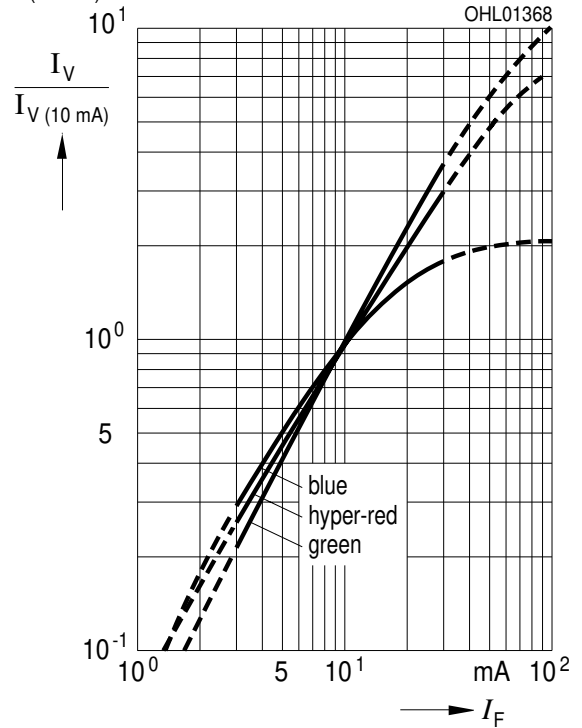

Durchlassstrom^{(6) 7) Seite 19}

Forward Current^{(6) 7) page 19}

$I_F = f(V_F); T_A = 25\text{ °C}; \text{blue}$

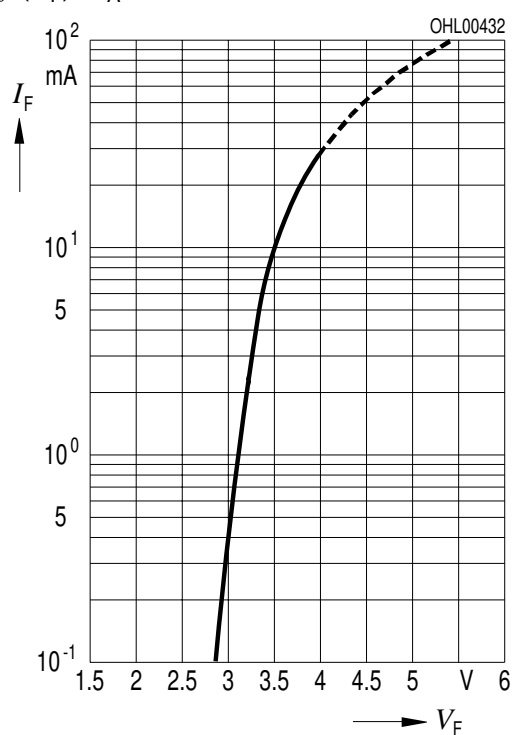

Relative Lichtstärke^{(6) Seite 19}

Relative Luminous Intensity^{(6) page 19}

$I_V/I_{V(25\text{ °C})} = f(T_j); I_F = 10\text{ mA}$

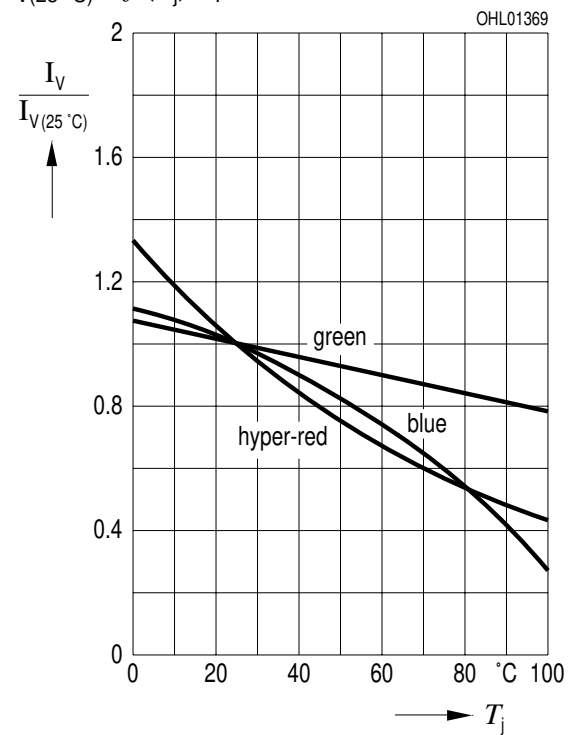

Maximal zulässiger Durchlassstrom
Max. Permissible Forward Current

$I_F = f(T)$; 1 chip on

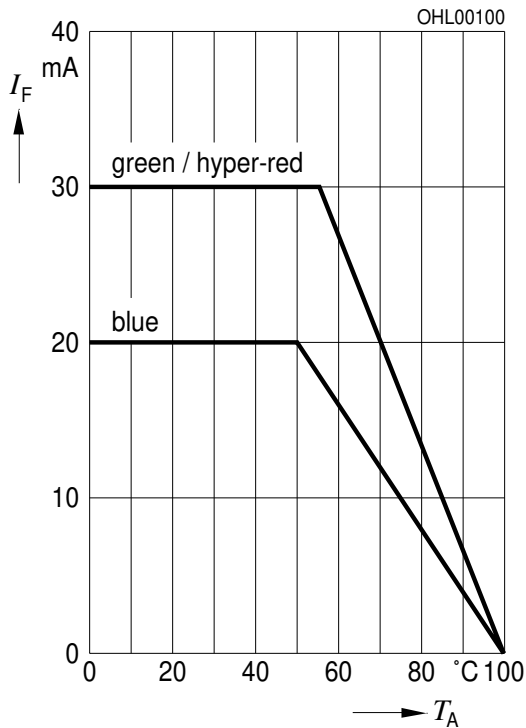

Maximal zulässiger Durchlassstrom
Max. Permissible Forward Current

$I_F = f(T)$; 3 chips on

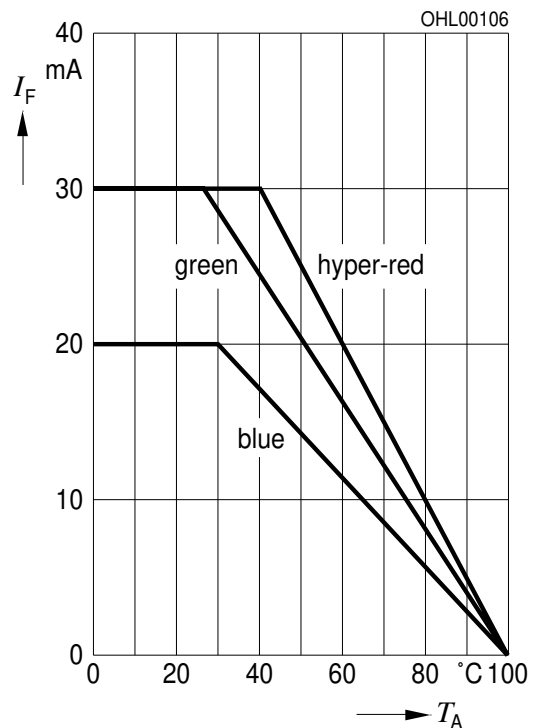

Maximal zulässiger Durchlassstrom
Max. Permissible Forward Current

$I_F = f(T)$; 1 chip on

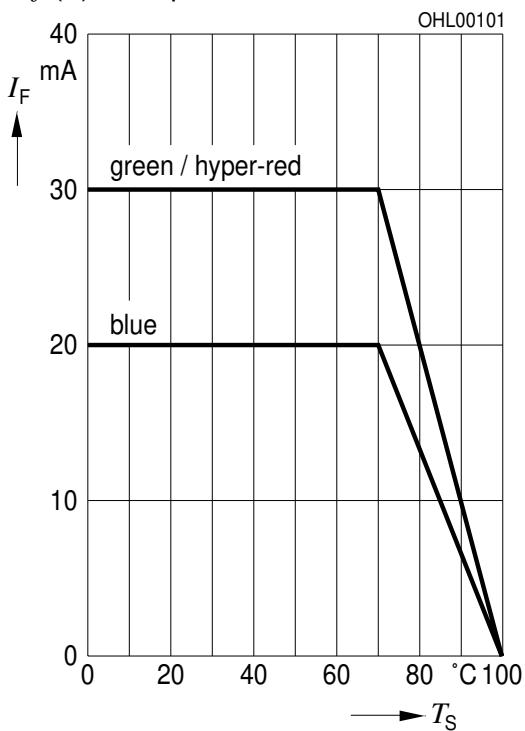

Maximal zulässiger Durchlassstrom
Max. Permissible Forward Current

$I_F = f(T)$; 3 chips on

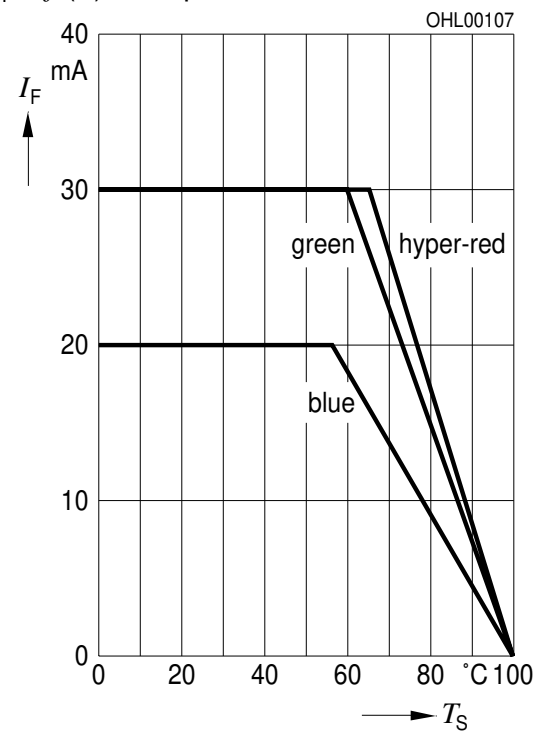

Zulässige Impulsbelastbarkeit $I_F = f(t_p)$
Permissible Pulse Handling Capability
 Duty cycle $D =$ parameter, $T_A = 25\text{ °C}$
blue (1 Chip on)

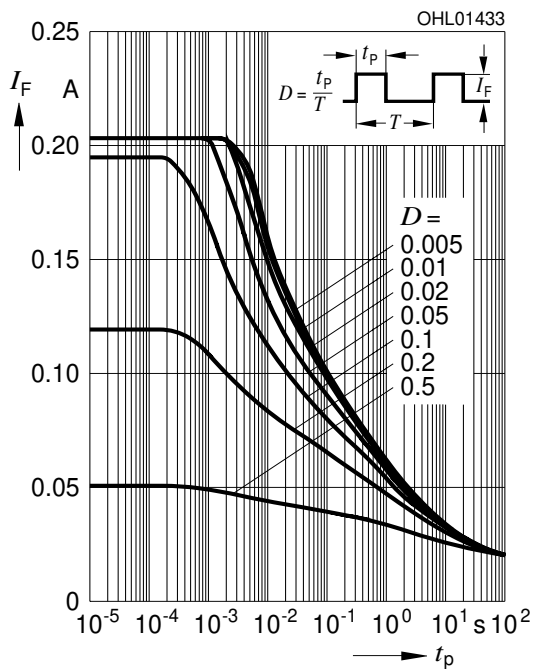

Zulässige Impulsbelastbarkeit $I_F = f(t_p)$
Permissible Pulse Handling Capability
 Duty cycle $D =$ parameter, $T_A = 85\text{ °C}$
blue (1Chip on)

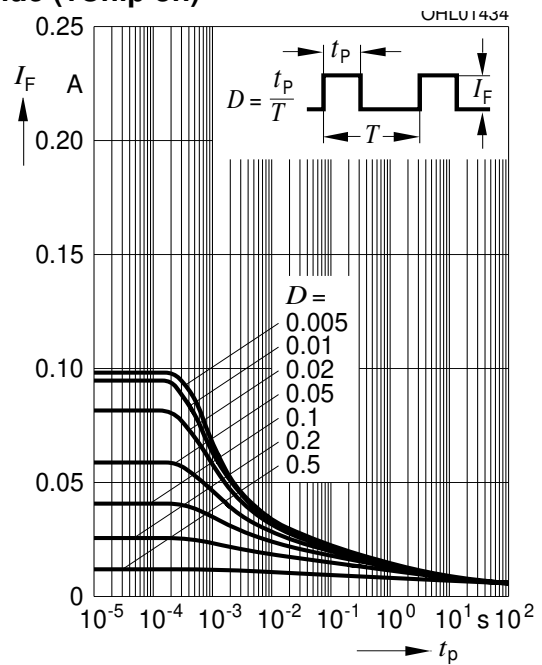

Zulässige Impulsbelastbarkeit $I_F = f(t_p)$
Permissible Pulse Handling Capability
 Duty cycle $D =$ parameter, $T_A = 25\text{ °C}$
blue (3 Chips on)

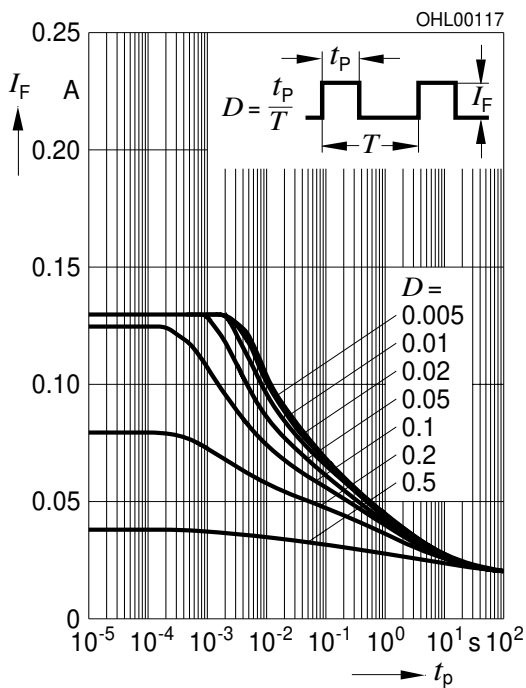

Zulässige Impulsbelastbarkeit $I_F = f(t_p)$
Permissible Pulse Handling Capability
 Duty cycle $D =$ parameter, $T_A = 85\text{ °C}$
blue (3 Chips on)

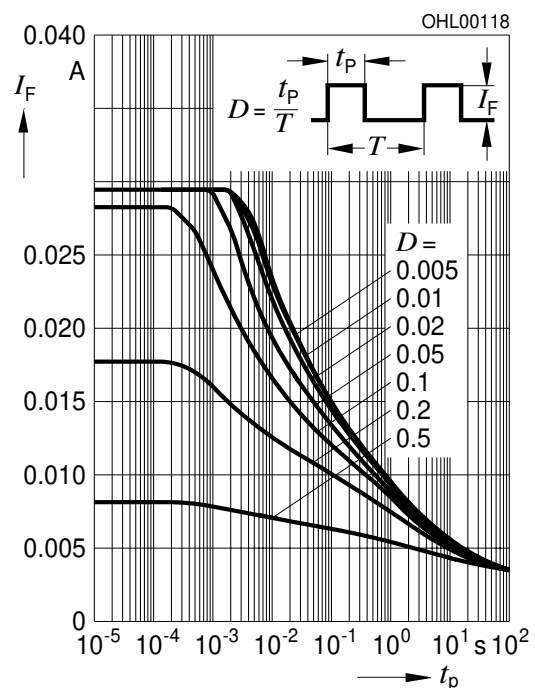

Zulässige Impulsbelastbarkeit $I_F = f(t_p)$
Permissible Pulse Handling Capability
 Duty cycle $D =$ parameter, $T_A = 25\text{ °C}$
 green/hyper-red (1 Chip on)

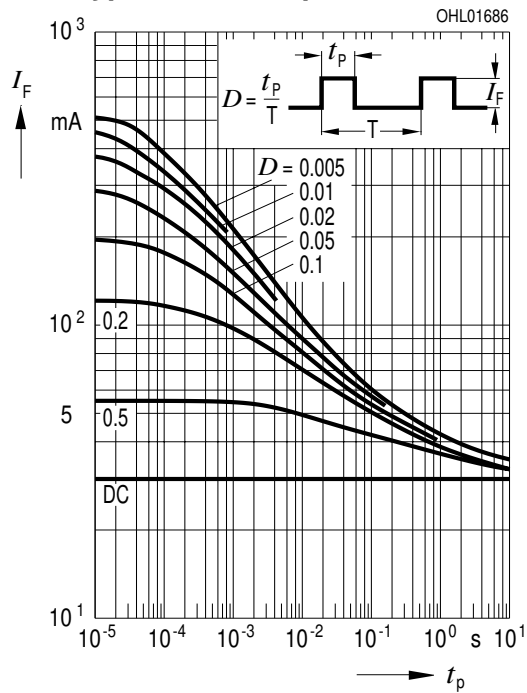

Zulässige Impulsbelastbarkeit $I_F = f(t_p)$
Permissible Pulse Handling Capability
 Duty cycle $D =$ parameter, $T_A = 85\text{ °C}$
 green/hyper-red (1 Chip on)

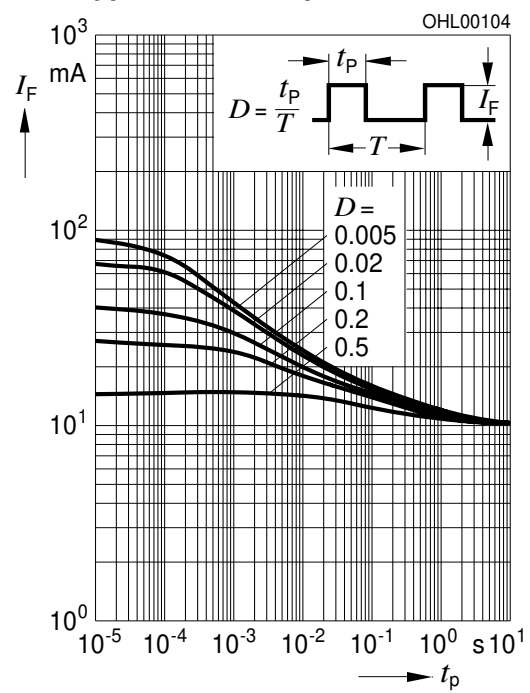

Zulässige Impulsbelastbarkeit $I_F = f(t_p)$
Permissible Pulse Handling Capability
 Duty cycle $D =$ parameter, $T_A = 25\text{ °C}$
 green (3 Chips on)

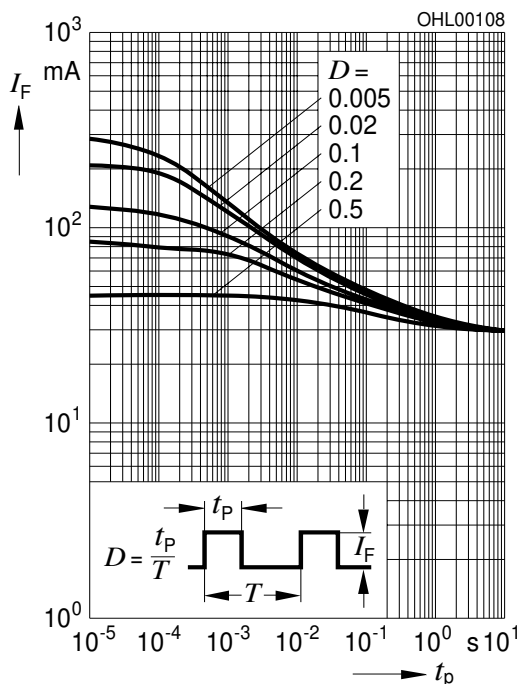

Zulässige Impulsbelastbarkeit $I_F = f(t_p)$
Permissible Pulse Handling Capability
 Duty cycle $D =$ parameter, $T_A = 85\text{ °C}$
 green (3 Chips on)

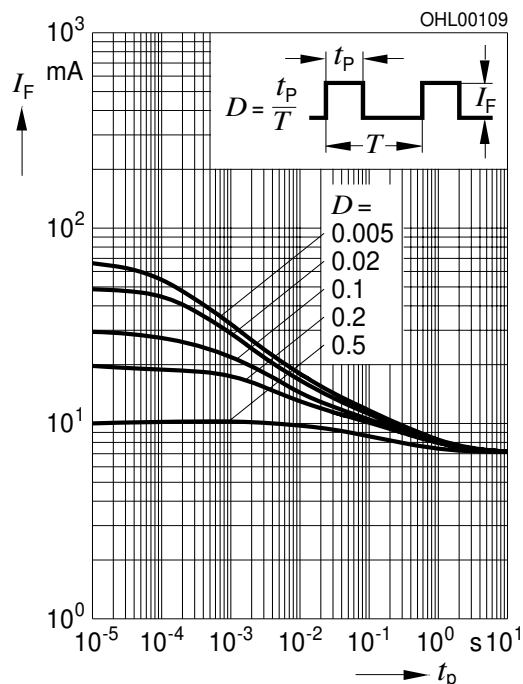

Zulässige Impulsbelastbarkeit $I_F = f(t_p)$
Permissible Pulse Handling Capability
 Duty cycle $D =$ parameter, $T_A = 25\text{ °C}$
 hyper-red (3 Chips on)

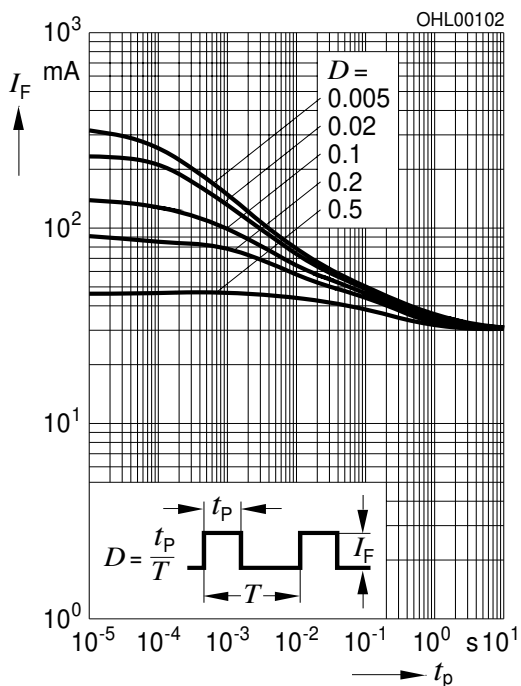

Zulässige Impulsbelastbarkeit $I_F = f(t_p)$
Permissible Pulse Handling Capability
 Duty cycle $D =$ parameter, $T_A = 85\text{ °C}$
 hyper-red (3 Chips on)

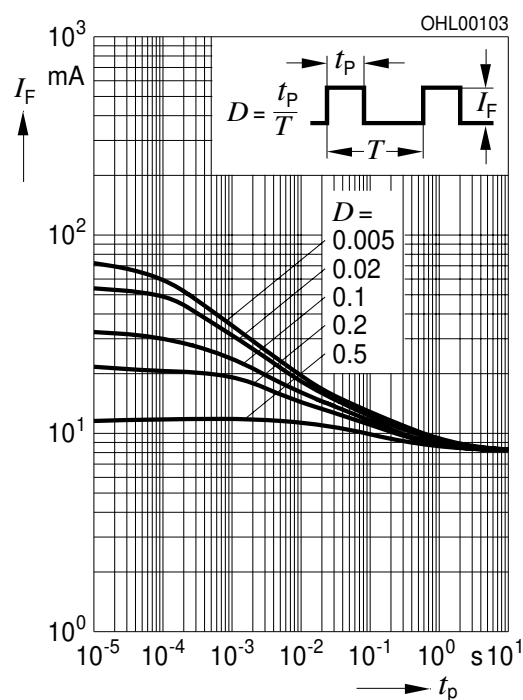

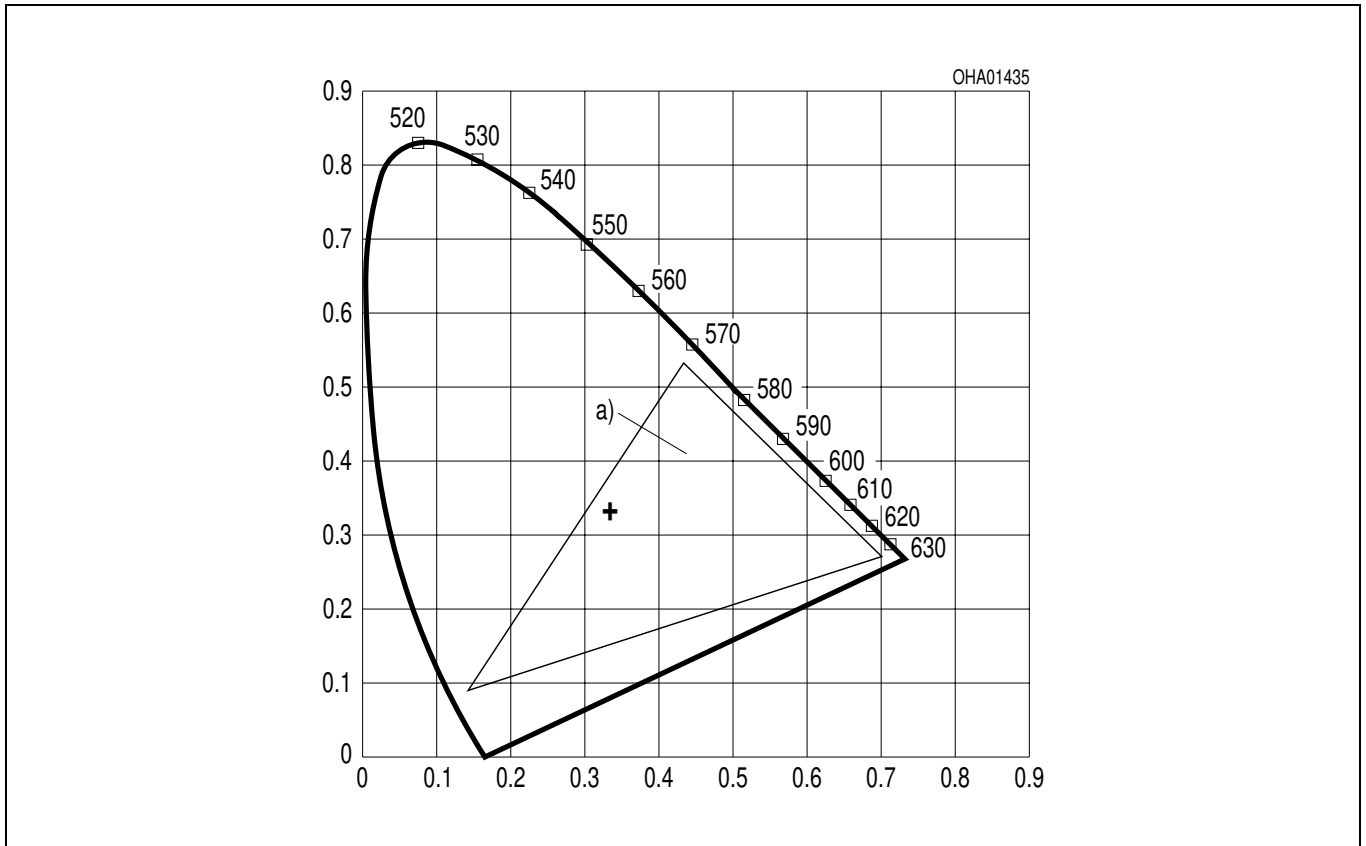

Die Farbkoordinaten des Mischlichtes können innerhalb des mit a) gekennzeichneten Bereichs des Farbdreiecks erwartet werden.

Der Unbuntpunkt ($x = 0,33$, $y = 0,33$) ist mit „+“ gekennzeichnet.

The color coordinates of the mixed light can be expected within the area of the color triangle marked a).

The achromatic point ($x = 0.33$, $y = 0.33$) is marked “+”.

Empfohlenes Lötpad Design⁸⁾ Seite 19
Recommended Solder Pad⁸⁾ page 19

IR Reflow Löten
IR Reflow Soldering

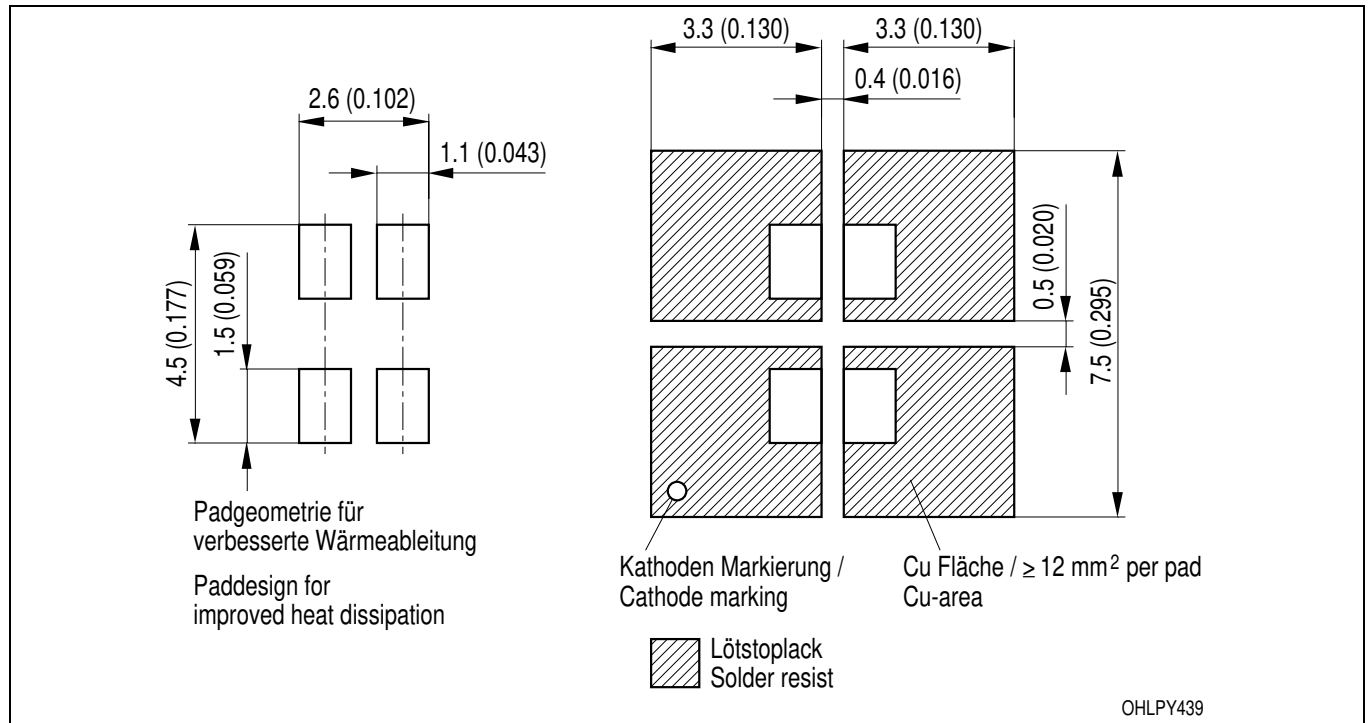

Empfohlenes Lötpad Design⁸⁾ Seite 19
Recommended Solder Pad⁸⁾ page 19

Wellenlöten (TTW)
TTW Soldering

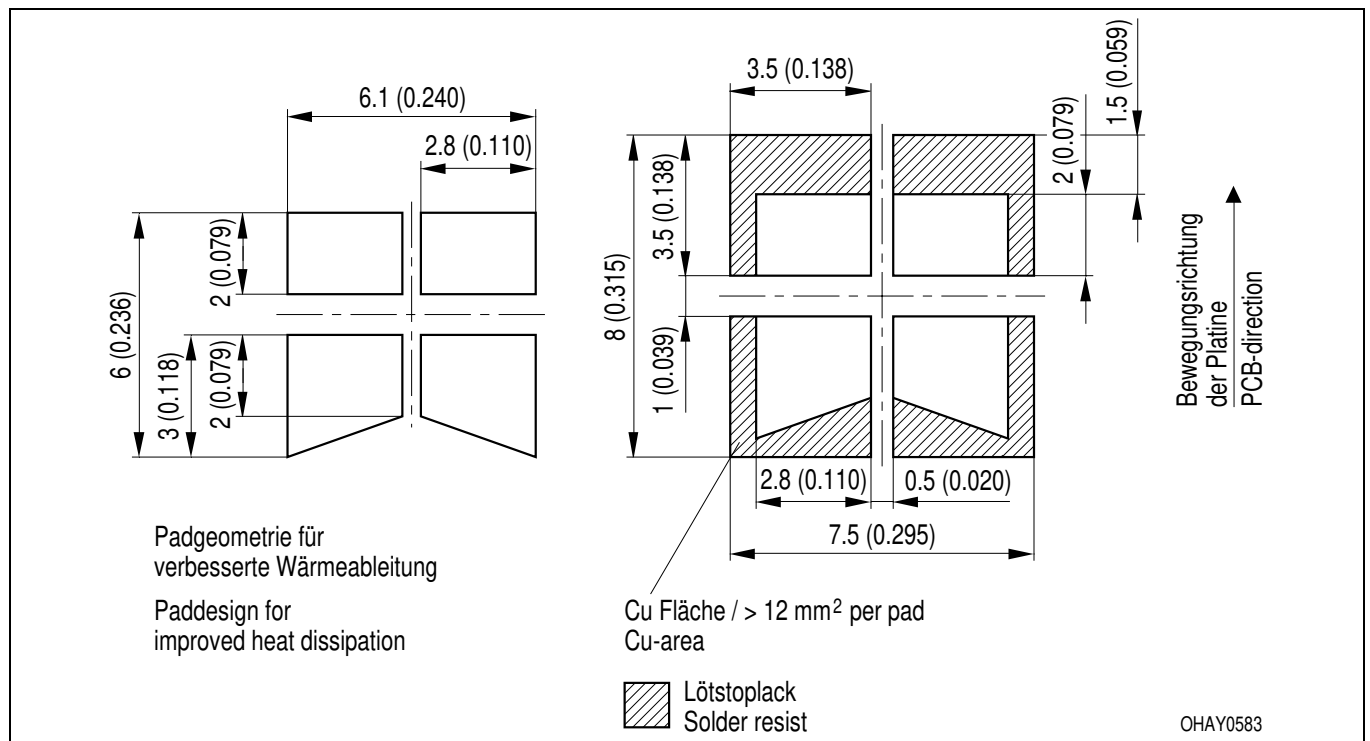

Lötbedingungen
Soldering Conditions

Vorbehandlung nach JEDEC Level 2
Preconditioning acc. to JEDEC Level 2

IR-Reflow Lötprofil
IR Reflow Soldering Profile

(nach IPC 9501)
(acc. to IPC 9501)

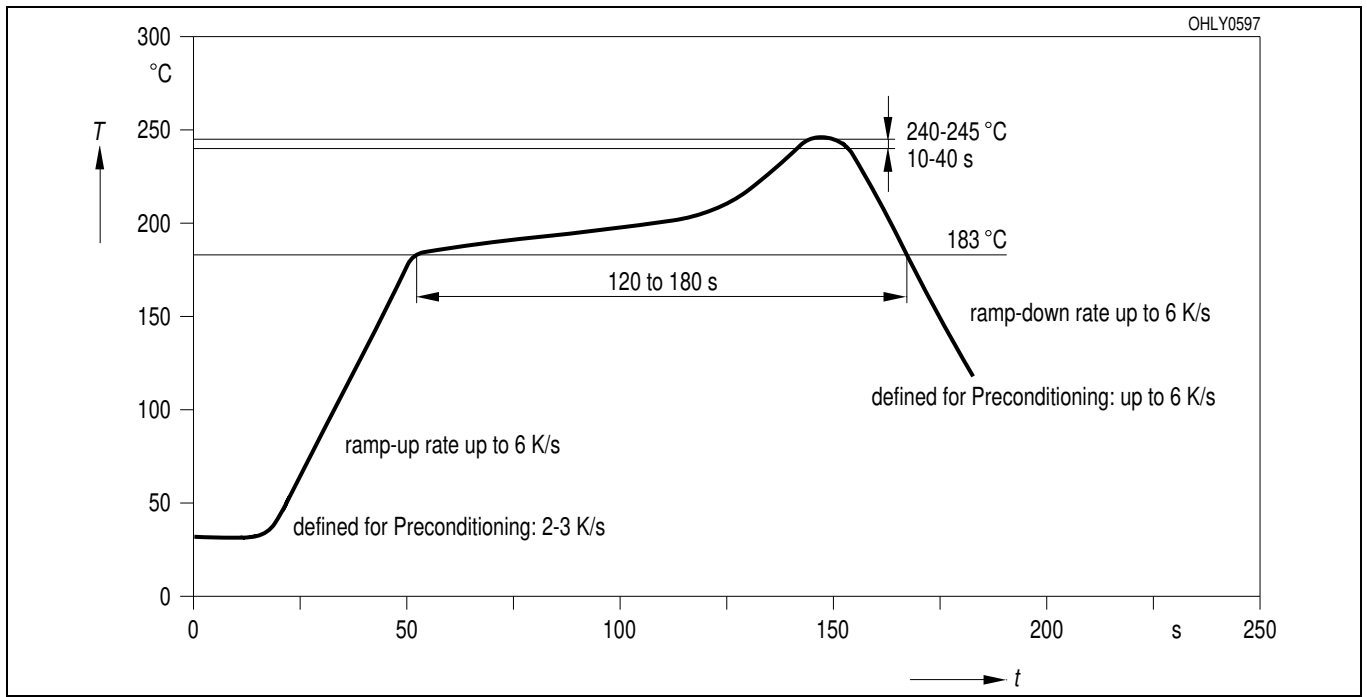

Wellenlöten (TTW)
TTW Soldering

(nach CECC 00802)
(acc. to CECC 00802)

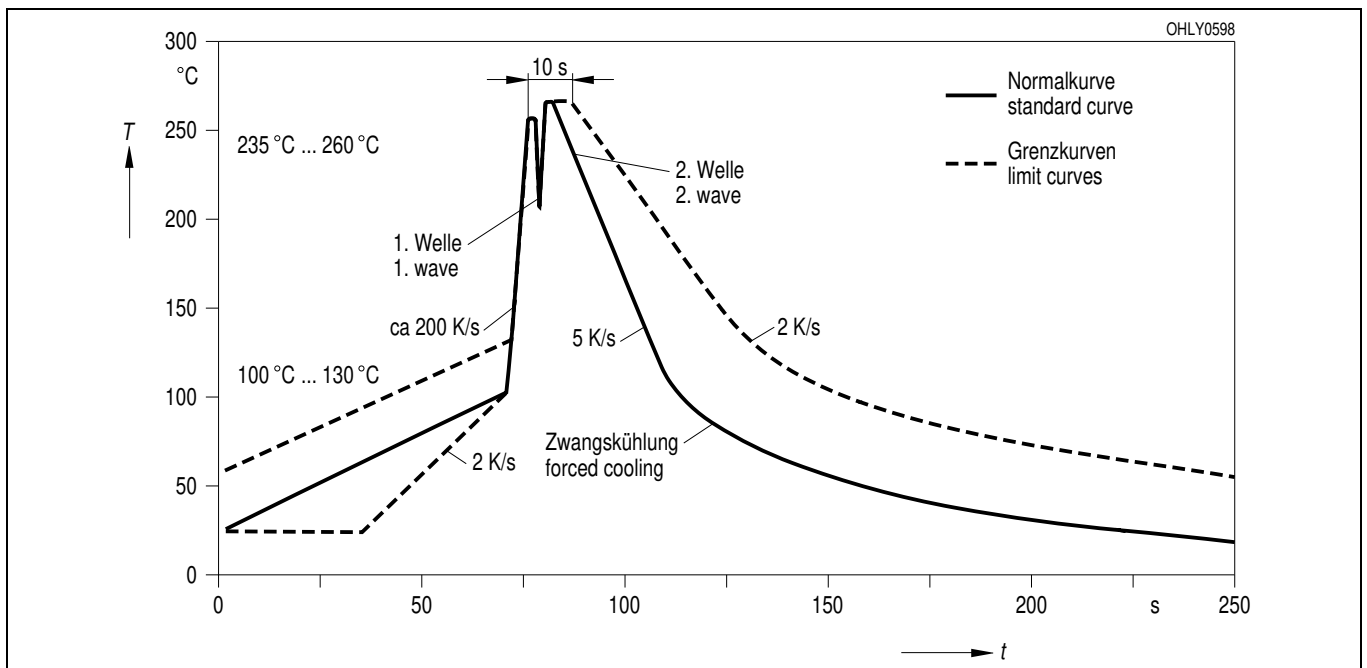

Barcode-Produkt-Etikett (BPL)
Barcode-Product-Label (BPL)

OSRAM Opto Semiconductors

Lx:xxxx Bin1: Bin Information Color 1
 Product Name Bin2:
 Bin3:

(6P) BATCH NO: Batch Number
Bar Code

(1T) LOT NO: Lot Number (9D) D/C: Date Code
Bar Code

(X) PROD NO: Product Code (Q) QTY: Product Quantity per Reel (G) GROUP: X - X - X
Bar Code

ML Temp ST
 2 245 C R
 2 260 C T

Additional TEXT
 R077 DEMY
 PACKVAR: Packing Type

Forward Voltage Rank
 Wavelength Rank
 Brightness Rank

OHA02043

Gurtverpackung
Tape and Reel

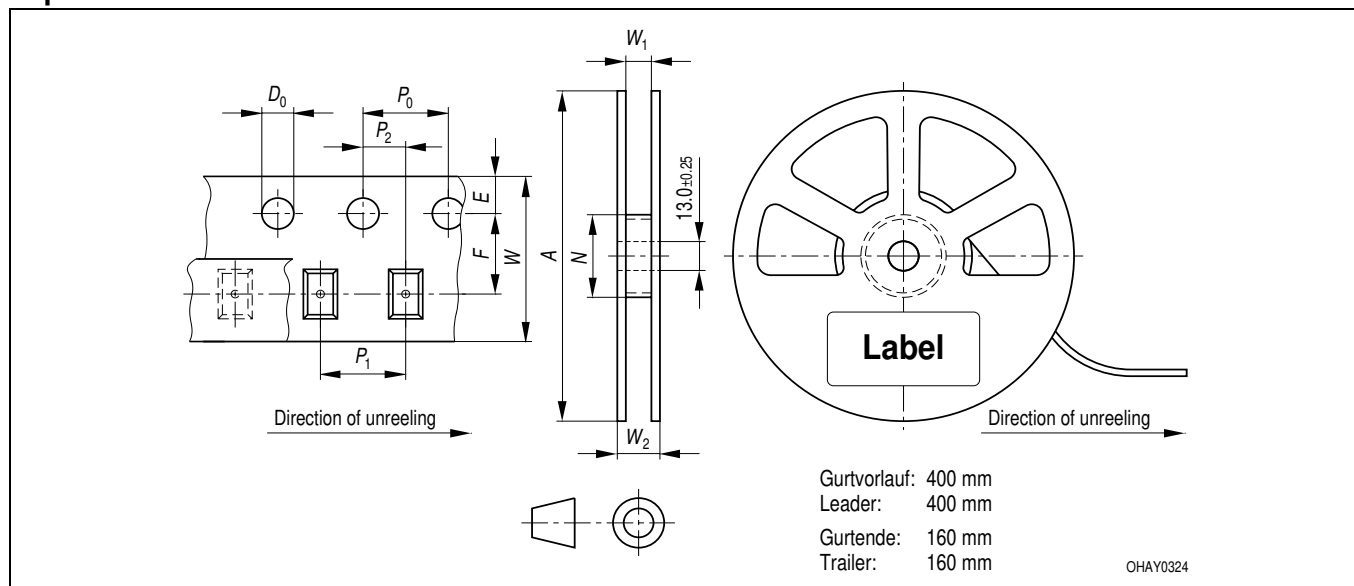

Tape dimensions in mm (inch)

W	P ₀	P ₁	P ₂	D ₀	E	F
8 + 0.3 - 0.1	4 ± 0.1 (0.157 ± 0.004)	4 ± 0.1 (0.157 ± 0.004)	2 ± 0.05 (0.079 ± 0.002)	1.5 + 0.1 (0.059 + 0.004)	1.75 ± 0.1 (0.069 ± 0.004)	3.5 ± 0.05 (0.138 ± 0.002)

Reel dimensions in mm (inch)

A	W	N _{min}	W ₁	W _{2 max}
330 (13)	8 (0.315)	60 (2.362)	8.4 + 2 (0.331 + 0.079)	14.4 (0.567)

Trockenverpackung und Materialien
Dry Packing Process and Materials

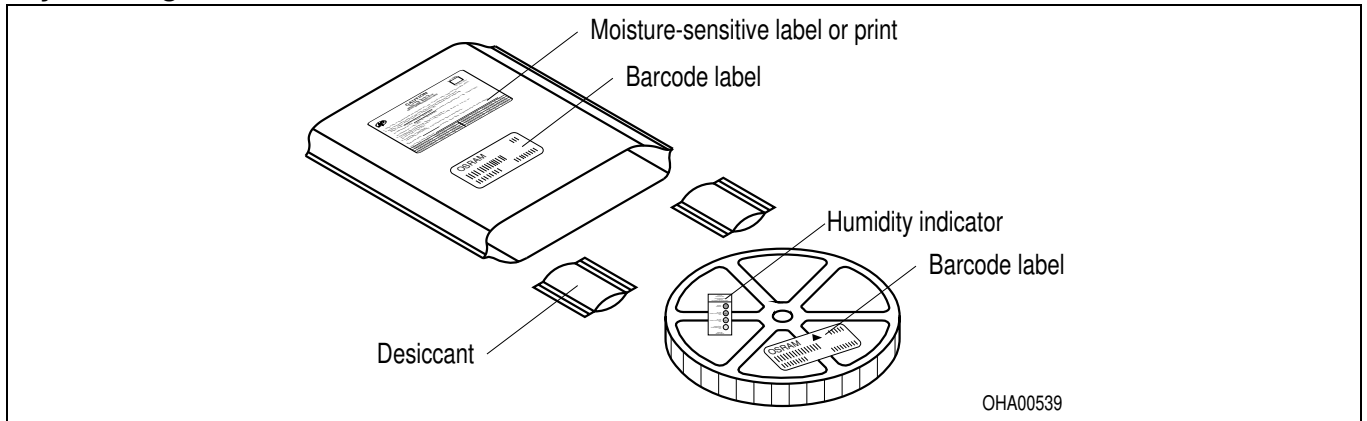

Anm.: Feuchteempfindliche Produkte sind verpackt in einem Trockenbeutel zusammen mit einem Trockenmittel und einer Feuchteindikatorkarte
Bezüglich Trockenverpackung finden Sie weitere Hinweise im Internet und in unserem Short Form Catalog im Kapitel "Gurtung und Verpackung" unter dem Punkt "Trockenverpackung". Hier sind Normenbezüge, unter anderem ein Auszug der JEDEC-Norm, enthalten.

Note: Moisture-sensitive product is packed in a dry bag containing desiccant and a humidity card.
Regarding dry pack you will find further information in the internet and in the Short Form Catalog in chapter "Tape and Reel" under the topic "Dry Pack". Here you will also find the normative references like JEDEC.

Kartonverpackung und Materialien
Transportation Packing and Materials

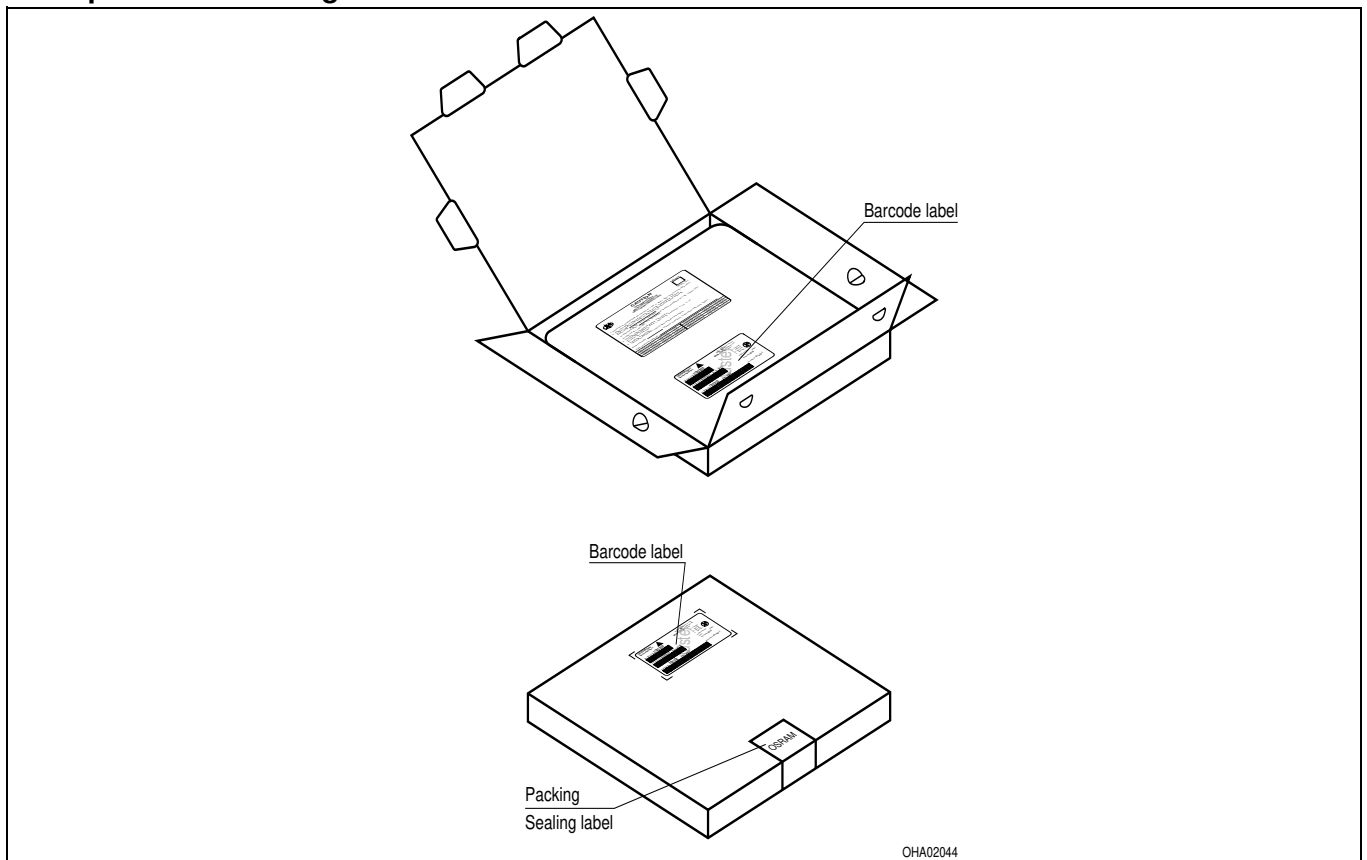

Revision History: 2005-03-03

Previous Version: 2004-08-13

Page	Subjects (major changes since last revision)	Date of change
4	Durchlassspannung / Forward voltage (typ.)	
2	Luminous intensity grouping (B)	
17	annotations	2002-07-23
3, 4	value (reverse voltage)	2002-09-18
3, 4	hyper-red & blue: value (reverse voltage from 12 V to 5 V)	2003-02-11
3	ambient temperature	2003-09-09
all	new template	2004-03-09
all	Product Discontinuation	2005-03-03

Attention please!

The information describes the type of component and shall not be considered as assured characteristics. Terms of delivery and rights to change design reserved. Due to technical requirements components may contain dangerous substances. For information on the types in question please contact our Sales Organization. If printed or downloaded, please find the latest version in the Internet.

Packing

Please use the recycling operators known to you. We can also help you – get in touch with your nearest sales office. By agreement we will take packing material back, if it is sorted. You must bear the costs of transport. For packing material that is returned to us unsorted or which we are not obliged to accept, we shall have to invoice you for any costs incurred.

Components used in life-support devices or systems must be expressly authorized for such purpose! Critical components^{9) page 19} may only be used in life-support devices or systems^{10) page 19} with the express written approval of OSRAM OS.

Fußnoten:

- 1) Helligkeitswerte werden mit einer Stromeinprägedauer von 25 ms und einer Genauigkeit von $\pm 11\%$ ermittelt.
- 2) Die LED kann kurzzeitig in Sperrichtung betrieben werden.
- 3) R_{thJA} ergibt sich bei Montage auf PC-Board FR 4 (Padgröße $\geq 16 \text{ mm}^2$ je Pad)
- 4) Wellenlängen werden mit einer Stromeinprägedauer von 25 ms und einer Genauigkeit von $\pm 1 \text{ nm}$ ermittelt.
- 5) Spannungswerte werden mit einer Stromeinprägedauer von 1 ms und einer Genauigkeit von $\pm 0,1 \text{ V}$ ermittelt.
- 6) Wegen der besonderen Prozessbedingungen bei der Herstellung von LED können typische oder abgeleitete technische Parameter nur aufgrund statistischer Werte wiedergegeben werden. Diese stimmen nicht notwendigerweise mit den Werten jedes einzelnen Produktes überein, dessen Werte sich von typischen und abgeleiteten Werten oder typischen Kennlinien unterscheiden können. Falls erforderlich, z.B. aufgrund technischer Verbesserungen, werden diese typischen Werte ohne weitere Ankündigung geändert.
- 7) Im gestrichelten Bereich der Kennlinien muss mit erhöhten Helligkeitsunterschieden zwischen Leuchtdioden innerhalb einer Verpackungseinheit gerechnet werden.
- 8) Maße werden wie folgt angegeben: mm (inch)
- 9) Ein kritisches Bauteil ist ein Bauteil, das in lebenserhaltenden Apparaten oder Systemen eingesetzt wird und dessen Defekt voraussichtlich zu einer Fehlfunktion dieses lebenserhaltenden Apparates oder Systems führen wird oder die Sicherheit oder Effektivität dieses Apparates oder Systems beeinträchtigt.
- 10) Lebenserhaltende Apparate oder Systeme sind für
 - (a) die Implantierung in den menschlichen Körper oder
 - (b) für die Lebenserhaltung bestimmt.
 Falls sie versagen, kann davon ausgegangen werden, dass die Gesundheit und das Leben des Patienten in Gefahr ist.

Remarks:

- 1) Brightness groups are tested at a current pulse duration of 25 ms and a tolerance of $\pm 11\%$.
- 2) Driving the LED in reverse direction is suitable for short term application.
- 3) R_{thJA} results from mounting on PC board FR 4 (pad size $\geq 16 \text{ mm}^2$ per pad)
- 4) Wavelengths are tested at a current pulse duration of 25 ms and a tolerance of $\pm 1 \text{ nm}$.
- 5) Forward voltages are tested at a current pulse duration of 1 ms and a tolerance of $\pm 0.1 \text{ V}$.
- 6) Due to the special conditions of the manufacturing processes of LED, the typical data or calculated correlations of technical parameters can only reflect statistical figures. These do not necessarily correspond to the actual parameters of each single product, which could differ from the typical data and calculated correlations or the typical characteristic line. If requested, e.g. because of technical improvements, these typ. data will be changed without any further notice.
- 7) In the range where the line of the graph is broken, you must expect higher brightness differences between single LEDs within one packing unit.
- 8) Dimensions are specified as follows: mm (inch)
- 9) A critical component is a component used in a life-support device or system whose failure can reasonably be expected to cause the failure of that life-support device or system, or to affect its safety or the effectiveness of that device or system.
- 10) Life support devices or systems are intended
 - (a) to be implanted in the human body,
 - or
 - (b) to support and/or maintain and sustain human life.
 If they fail, it is reasonable to assume that the health and the life of the user may be endangered.