



Chipsmall Limited consists of a professional team with an average of over 10 year of expertise in the distribution of electronic components. Based in Hongkong, we have already established firm and mutual-benefit business relationships with customers from,Europe,America and south Asia,supplying obsolete and hard-to-find components to meet their specific needs.

With the principle of “Quality Parts,Customers Priority,Honest Operation,and Considerate Service”,our business mainly focus on the distribution of electronic components. Line cards we deal with include Microchip,ALPS,ROHM,Xilinx,Pulse,ON,Everlight and Freescale. Main products comprise IC,Modules,Potentiometer,IC Socket,Relay,Connector.Our parts cover such applications as commercial,industrial, and automotives areas.

We are looking forward to setting up business relationship with you and hope to provide you with the best service and solution. Let us make a better world for our industry!



## Contact us

Tel: +86-755-8981 8866 Fax: +86-755-8427 6832

Email & Skype: info@chipsmall.com Web: www.chipsmall.com

Address: A1208, Overseas Decoration Building, #122 Zhenhua RD., Futian, Shenzhen, China





The LightHAWK®2 Ultrasonic Wall Switch Sensor uses ultrasonic (US) technology for detecting minor movement in areas with line-of-sight obstacles such as cubicles and stalls. Ultrasonic technology is volumetric in nature, its coverage pattern can adapt itself to fill oddly shaped spaces such as alcoves, recesses, and nooks. This sensor has a coverage area of up to 400 square feet and 180° of detection.

LHUS sensors feature Hubbell Controls' patented IntelliDAPT™ technology, which makes all the sensor adjustment decisions automatically. Throughout the product's lifespan, smart software analyzes the controlled area and makes digital adjustments to sensitivity and timer settings. Occupancy sensors with IntelliDAPT technology provide a maintenance-free, install-and-forget operation. With selectable operating modes—automatic On/Off or manual On/automatic Off—and a built-in photosensor for automatic daylight harvesting, the LHUS sensors are the most capable choice in today's market place.

**Product Features**

- Digital Ultrasonic (US) sensor
- IntelliDAPT self-adaptive technology—no manual adjustment required
- Dual circuit has isolated relays
- Occupancy (auto-on) and Vacancy (manual-on) operating modes
- Available with or without Neutral
- 400 square-foot, 180° coverage area
- 120/277VAC operation
- No minimum load requirement
- Zero Arc Point Switching
- Five-year limited warranty
- 120-277VAC and 347VAC models
- Low voltage device: 24VDC

**Compliance and Certification**



**Dimensional Data**

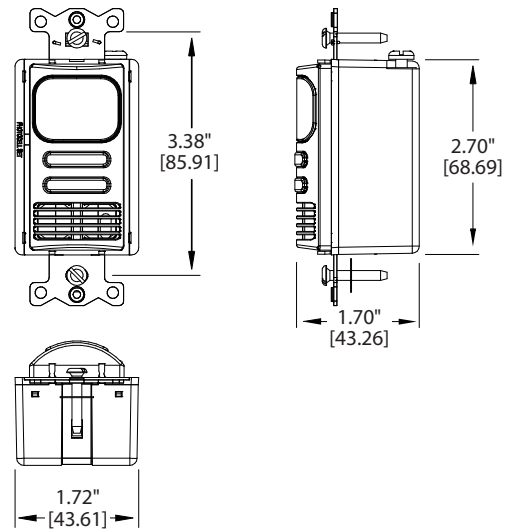

**Ordering Information**

MODEL	WIRING	COLOR	MODE
<b>LHUS00</b> Ultrasonic Technology Single Relay, No Button	<b>G</b> Ground (120/277V)	<b>WH</b> White	<b>(Blank)</b> Switchable Vacancy or Occupancy Mode
<b>LHUS01</b> Ultrasonic Technology Single Relay, One Button	<b>N</b> Neutral (120/277V)	<b>IV</b> Ivory	<b>M</b> Vacancy Mode Only
<b>LHUS00</b> Ultrasonic Technology, Dual Relay (One Input / Two Outputs), No Buttons	<b>24V</b> Low Voltage	<b>LA</b> Light Almond	
<b>LHUS02</b> Ultrasonic Technology, Dual Relay (One Input / Two Outputs), Two Buttons	<b>G347</b> Ground (347V)	<b>GY</b> Gray	
<b>LHDCUSD0</b> Ultrasonic Technology, Dual Circuit (Two Inputs / Two Outputs), No Buttons	<b>N347</b> Neutral (347V)	<b>BK</b> Black	
<b>LHDCUSD2</b> Ultrasonic Technology, Dual Circuit (Two Inputs / Two Outputs), Two Buttons			

\*Not available with LHDCUSD version  
-Low voltage sensors require a power pack that is sold separately

## Coverage Pattern

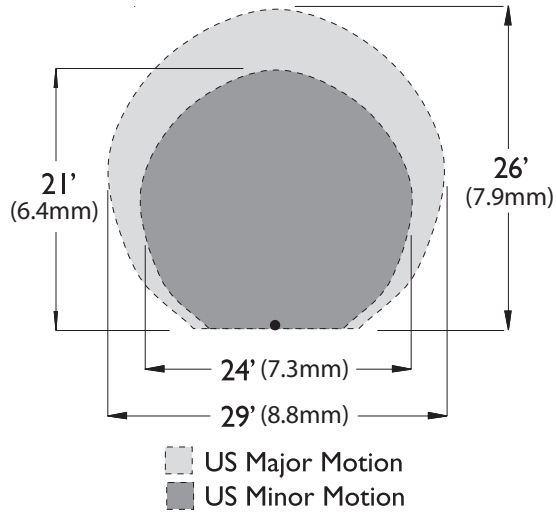

## Wiring Diagram

Single Load Wiring Without Neutral

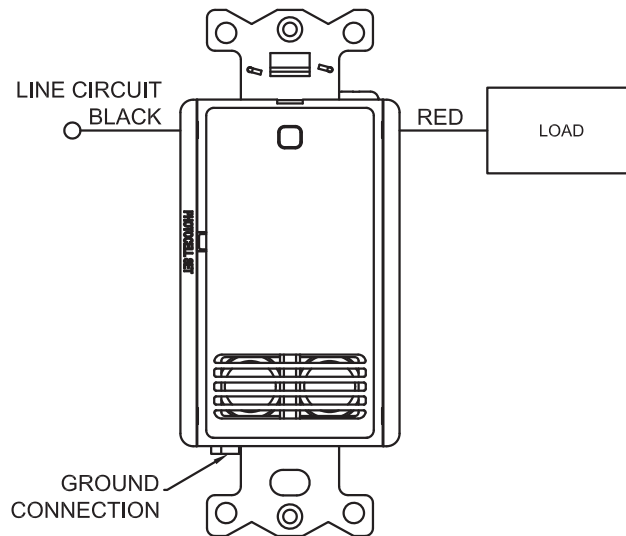

# Wiring Diagram

## Dual Load Wiring With Neutral

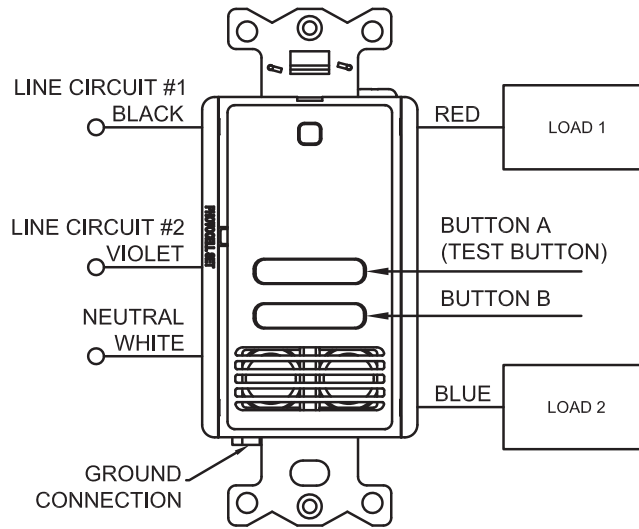

## Low Voltage Dual Level Control with Two Power Packs

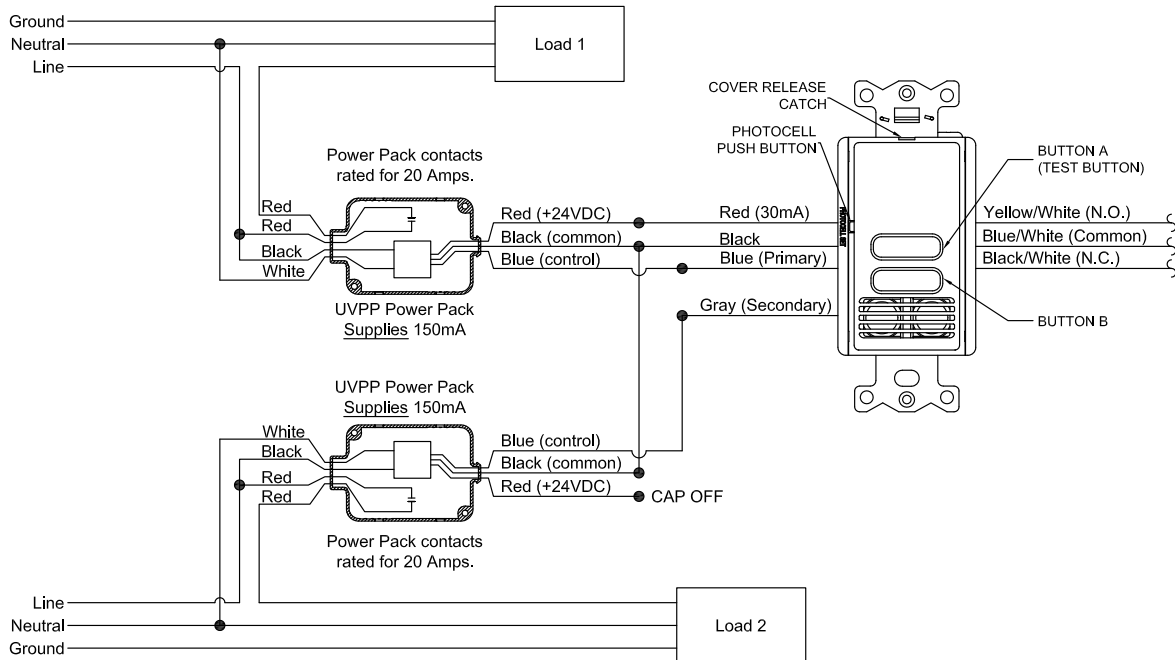



## General Specifications

IntelliDAPT Technology	Self-adjusting timer Self-adjusting Ultrasonic (US) and passive infrared (PIR) sensitivity Automatic false-on/ false-off corrections No manual adjustments required
Time Delay	Auto mode: 4-30 minutes; self-adjusts based on occupancy Fixed mode: 4, 8, 15, and 30 minutes Test mode: 5 seconds
Ultrasonic (US) Output	40kHz output
Photocell	Natural light override range: 10-500 foot-candles
Coverage	400 square-foot, 180° coverage area
Power Requirements	120/277VAC;50/60Hz 347VAC; 50/60Hz 24VDC (requires UVPP)
Electrical Ratings	120VAC: 800W Incandescent/ Electronic Ballast/ LED Driver: 1,000W Magentic Ballast 1/6 HP Motor 277VAC: 1,800W Magnetic Ballast/ Electronic Ballast/ LED Driver: 1/6 HP Motor 347VAC: 1,500W Magnetic Ballast/ Electronic Ballast/ LED Driver: 1/6 HP Motor
Operating Environment	Indoor use only Operating temperature: 32° to 104°F (0° to 40°C) Relative humidity (non-condensing): 0% to 95%
Construction	Casing- high- Impact injection-molded plastic (UL-94-5V) Impact-resistant lens Color- coded leads are 6" (152.4mm) long Wrap-around galvanized steel mounting strap
Dimensions	4.2" H x 1.8"W x 1.75"D; .37" extension (106.68mm H x 44.45mm D; 9.4mm ext.)
Weight	2.9 oz (82.21g)
Color	White; Ivory; Light Almond; Gray; Black
Mounting	Single-gang NEMA-style switch box (standard switch box) Decorator-style wall plate sold separately
Certifications	Listed UL and cUL
Warranty	Five-year limited