



Chipsmall Limited consists of a professional team with an average of over 10 year of expertise in the distribution of electronic components. Based in Hongkong, we have already established firm and mutual-benefit business relationships with customers from,Europe,America and south Asia,supplying obsolete and hard-to-find components to meet their specific needs.

With the principle of “Quality Parts,Customers Priority,Honest Operation,and Considerate Service”,our business mainly focus on the distribution of electronic components. Line cards we deal with include Microchip,ALPS,ROHM,Xilinx,Pulse,ON,Everlight and Freescale. Main products comprise IC,Modules,Potentiometer,IC Socket,Relay,Connector.Our parts cover such applications as commercial,industrial, and automotives areas.

We are looking forward to setting up business relationship with you and hope to provide you with the best service and solution. Let us make a better world for our industry!



Contact us

Tel: +86-755-8981 8866 Fax: +86-755-8427 6832

Email & Skype: info@chipsmall.com Web: www.chipsmall.com

Address: A1208, Overseas Decoration Building, #122 Zhenhua RD., Futian, Shenzhen, China



CUSTOMER PROOFING/CONFORMANCE FORM



Our commitment. Your advantage

Tyco Electronics Idento GmbH

Paul-Ehrlich-Str. 23
63322 Rödermark

Telephone: +49(0) 6074 8908 (0)
Facsimile: +49(0) 6074 8908 82
E.mail: idento@tycoelectronics.com
Website: www.idento.de

Attention of: *Tyco Electronics*

Drawing No.: *LKZ 31*

Tyco Part: *-*

Name: _____ Signature: _____

Date: _____



PLEASE NOTE

This form is an important part of our contract review and your order cannot be processed further until the necessary approval has been obtained.

We wish to provide a quality service to you and are conscious that a lengthy delay at this stage could affect any quoted delivery requirements. Delays in excess of 2 working days could result in delivery times being untenable. Please indicate below your acceptance and/or amendments and return this form as soon as is practicable.

Any amendments to the original design will be charged out @ Euros 40 each conformance to cover administration

Orders which remain on conformance with a customer for more than 2 weeks are placed in quarantine this may result in no further action or possible cancellation, however please be assured that we will attempt to contact you before this action

LABEL SPECIFICATION

These are our standard tolerances unless specified by customers drawing

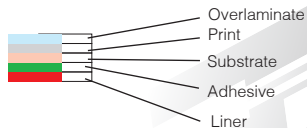
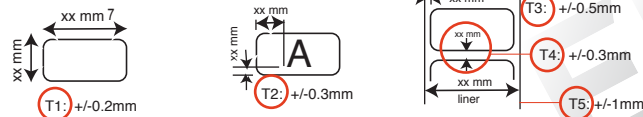

PRINTING

LKZ31 L1 377600-000 x■	LKZ31 L2 522120-000 x■	LKZ31 L3 047342-000 x■	LKZ31 N 2-1768035-9 x■		
LKZ31 L-PULS 2-1768035-8 x■	LKZ31 L-MINUS 2-1768035-7 x■	LKZ31 PE 828270-000 ●■	LKZ31 PEN 3-1768035-0 ●■	LKZ31 E 2-1768035-6 x■	LKZ31 B1 1-1768035-9 x■
LKZ31 B2 2-1768035-0 x■	LKZ31 B3 2-1768035-1 x■	LKZ31 B4 2-1768035-2 ●■	LKZ31 B5 2-1768035-3 x■	LKZ31 B6 2-1768035-4 x■	LKZ31 B7 2-1768035-5 x■

DIMENSION 50%

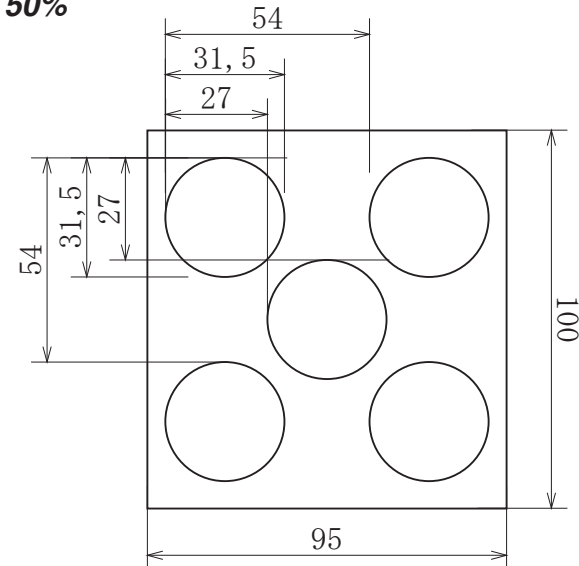

Description	Material	Nom. Thickness	Adhesive Type
LKZ 31	x PV501 soft PVC white	0,08mm	Acrykleber permanent
	● PV003 soft PVC yellow	0,07mm	Acrykleber permanent
	■ PE103 Polyester transparent	0,023mm	Permanent acrylic adhesive
TITLE Label	REV A1	DRAWN BY Inka Peitz 17/03/10	DRAWING No. LKZ 31
MODIFICATION		DATE	PLAN No. -
APPROVED BY N. Harputoglu		DATE	FOLDER Rödermark Mär10
			PAGE 1 Customer