



Chipsmall Limited consists of a professional team with an average of over 10 year of expertise in the distribution of electronic components. Based in Hongkong, we have already established firm and mutual-benefit business relationships with customers from,Europe,America and south Asia,supplying obsolete and hard-to-find components to meet their specific needs.

With the principle of “Quality Parts,Customers Priority,Honest Operation,and Considerate Service”,our business mainly focus on the distribution of electronic components. Line cards we deal with include Microchip,ALPS,ROHM,Xilinx,Pulse,ON,Everlight and Freescale. Main products comprise IC,Modules,Potentiometer,IC Socket,Relay,Connector.Our parts cover such applications as commercial,industrial, and automotives areas.

We are looking forward to setting up business relationship with you and hope to provide you with the best service and solution. Let us make a better world for our industry!



## Contact us

Tel: +86-755-8981 8866 Fax: +86-755-8427 6832

Email & Skype: info@chipsmall.com Web: www.chipsmall.com

Address: A1208, Overseas Decoration Building, #122 Zhenhua RD., Futian, Shenzhen, China



# DATA SHEET

## Liquid Level Switches

### Honeywell LLE Standard Temp Series Alternatives

For part numbers LLE101000, LLE102000, LLE103000 and LLE105000



#### FEATURES

- Liquid level switches that can detect almost any liquid type; oil or water based
- Choice of mounting; internal or external
- Choice of threads



<b>Housing/ Mounting</b>  M10x1  M12x1	<b>Output Type/Logic</b>  PUSH PULL  1 0 HIGH IN AIR	<b>Supply Voltage</b>  4.5 - 15.4 V VOLTAGE	<b>Output Current</b>  UP TO 100mA CURRENT	<b>Temp</b>  -25°C to +80°C TEMPERATURE
--	--	--	---	---

#### BENEFITS

- Low power
- Low cost
- Compact design

#### OUTPUT VALUES

**Output Voltage<sup>b</sup> (V<sub>out</sub>):** **I<sub>out</sub> = 100mA**  
Output High                      V<sub>out</sub> = V<sub>s</sub> - 1.5V max  
Output Low                        V<sub>out</sub> = 0V + 0.5V max

#### TECHNICAL SPECIFICATIONS

Supply voltage (V <sub>s</sub> )	4.5V <sub>DC</sub> to 15.4V <sub>DC</sub>
Supply current (I <sub>s</sub> )	2.5mA max. (V <sub>s</sub> = 15.4V <sub>DC</sub> )
Output sink and source current (I <sub>out</sub> )	100mA
Operating temperatures	-25°C to +80°C
Storage temperatures	-30°C to +85°C
Housing material <sup>a</sup>	Polysulfone
Sensor termination	24AWG, 250mm PTFE wires, 8mm tinned

Other sensor options available on request, email: [technical@sstsensing.com](mailto:technical@sstsensing.com)

**Need help? Ask the expert**  
**Tel: + 44 (0)1236 459 020**  
**and ask for "Technical"**



- a) Before use check that the fluid in which you wish to use these devices is compatible with Polysulfone.  
b) Voltages applicable to output value stated.



## OUTLINE DRAWING

All dimensions shown in mm. Tolerances =  $\pm 1$ mm.

**Type 1**

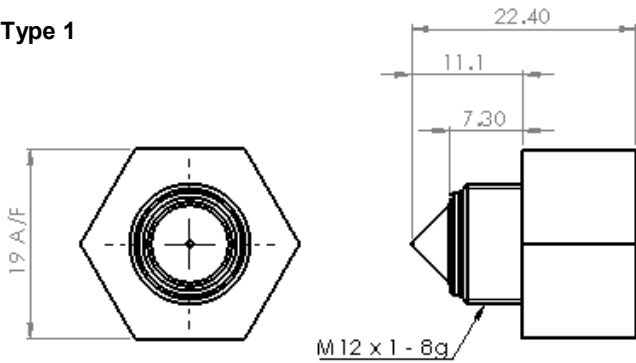

**Type 2**

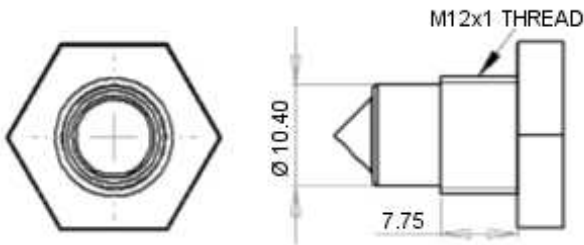

**Type 3**

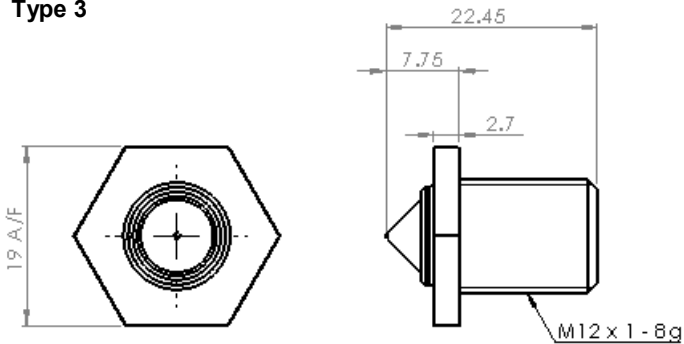

**Type 5**

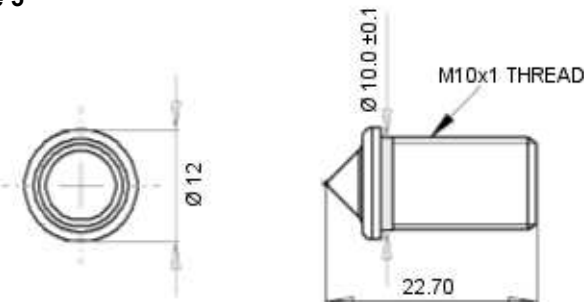

## HOUSING SPECIFICATIONS

Housing Series - External Mounting		
	Type 1	Type 2
Thread	M12x1x8g	M12x1x8g with hex nut <sup>c</sup>
Pressure <sup>d</sup>	7 bar / 101 psi maximum	
Tightening Torque	1.5 Nm / 13.26 in-lbs maximum	

Housing Series - Internal Mounting		
	Type 3	Type 5
Thread	M12x1x8g with hex nut <sup>c</sup>	M10x1
Pressure <sup>d</sup>	7 bar / 101 psi maximum	
Tightening Torque	1.5 Nm / 13.26 in-lbs maximum	Not Applicable

**NOTE:** In the cases of Type 1 and Type 3 sensors, the rear of the SST sensors are slightly longer than the Honeywell sensors.

**NOTE:** The dimensions of the Type 5 part make it a "push in" part the same as LLE105000. Note that the sensor can also be secured using an M10 nut.

## ELECTRICAL INTERFACE

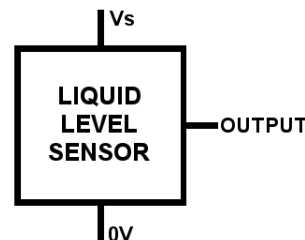

Wire	Designation
Red	Vs
Green	Output
Blue	0V



- c) Hex nut and washer supplied with Type 1, Type 2 and Type 3.  
 d) When correctly sealed.

**Digital Output High in Air**

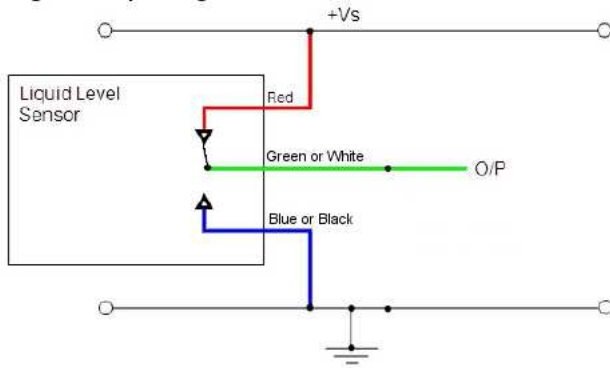

**CAUTION:** Take care when connecting loads.

The minimum load impedance should not exceed  $V_s/\text{max output current}$ .

**Note:** Shorting the output to  $V_s$  or  $0V$  will result in irreparable damage to the sensor.



**ORDER INFORMATION**

Specify the part number you require.

**Sensor mounted from outside vessel**

**Type 1**

L L C 1 0 1 0 0 0

**Type 2**

L L C 1 0 2 0 0 0

**Sensor mounted from inside vessel**

**Type 3**

L L C 1 0 3 0 0 0

**Type 5**

L L C 1 0 5 0 0 0

Please contact SST Sensing for details; email: [technical@sstsensing.com](mailto:technical@sstsensing.com)

 **CAUTION**

Do not exceed maximum ratings and ensure sensor(s) are operated in accordance with their requirements.

Carefully follow all wiring instructions. Incorrect wiring can cause permanent damage to the device.

SST Sensing Ltd recommend using alcohol based cleaning agents. Do NOT use chlorinated solvents such as trichloroethane as these are likely to attack the sensor material.

**Failure to comply with these instructions may result in product damage.**

 **INFORMATION**

As customer applications are outside of SST Sensing Ltd.'s control, the information provided is given without legal responsibility. Customers should test under their own conditions to ensure that the equipment is suitable for their intended application. Before use, check that the fluid in which you wish to use these devices is compatible with Polysulfone.

**For technical assistance or advice, please email:**  
[technical@sstsensing.com](mailto:technical@sstsensing.com)

**General Note:** SST Sensing Ltd. reserves the right to make changes to product specifications without notice or liability. All information is subject to SST Sensing Ltd.'s own data and considered accurate at time of going to print.