



Chipsmall Limited consists of a professional team with an average of over 10 year of expertise in the distribution of electronic components. Based in Hongkong, we have already established firm and mutual-benefit business relationships with customers from,Europe,America and south Asia,supplying obsolete and hard-to-find components to meet their specific needs.

With the principle of “Quality Parts,Customers Priority,Honest Operation,and Considerate Service”,our business mainly focus on the distribution of electronic components. Line cards we deal with include Microchip,ALPS,ROHM,Xilinx,Pulse,ON,Everlight and Freescale. Main products comprise IC,Modules,Potentiometer,IC Socket,Relay,Connector.Our parts cover such applications as commercial,industrial, and automotives areas.

We are looking forward to setting up business relationship with you and hope to provide you with the best service and solution. Let us make a better world for our industry!



Contact us

Tel: +86-755-8981 8866 Fax: +86-755-8427 6832

Email & Skype: info@chipsmall.com Web: www.chipsmall.com

Address: A1208, Overseas Decoration Building, #122 Zhenhua RD., Futian, Shenzhen, China



Four UA741 quad bipolar operational amplifiers

Datasheet - production data

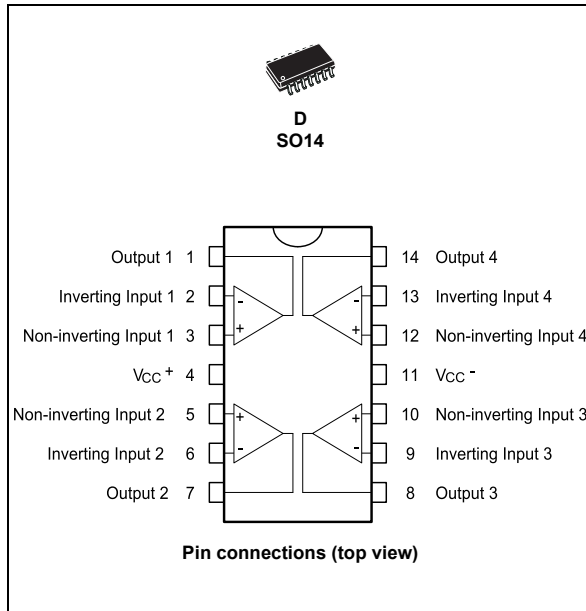

Description

The LM248 and LM348 consist of four independent, high-gain internally-compensated, low-power operational amplifiers which have been designed to provide functional characteristics identical to those of the familiar UA741 operational amplifier. In addition, the total supply current for all four amplifiers is compatible with the supply current of a single UA741 type operational amplifier. Other features include input offset current and input bias current which are much less than those of a standard UA741. Also, excellent isolation between amplifiers has been achieved by independently biasing each amplifier and using layout techniques which minimize thermal coupling.

The LM248 and LM348 can be used where multiple UA741 type amplifiers are being used and in applications where amplifier matching or high packaging density is required.

Features

- Low supply current: 0.53 mA per amplifier
- Class AB output stage: no crossover distortion
- Pin compatibility with LM124, LM224, LM324
- Low input offset voltage: 1 mV
- Low input offset current: 2 nA
- Low input bias current: 30 nA
- Gain bandwidth product: 1.3 MHz
- High degree of isolation between amplifiers: 120 dB
- Overload protection for inputs and outputs

Table 1. Device summary

Part number	Temperature range	Package
LM248	-40 °C to 105 °C	D ⁽¹⁾
LM348	0 °C to 70 °C	
Order code example: LM348DT ⁽²⁾		

1. D = Small outline package (SO)

2. See [Table 5: Order codes](#)

Contents

1	Schematic diagram	3
2	Absolute maximum ratings	4
3	Electrical characteristics	5
4	Package information	7
	4.1 SO14 package information	7
5	Ordering information	9
6	Revision history	9

1 Schematic diagram

Figure 1. Schematic diagram

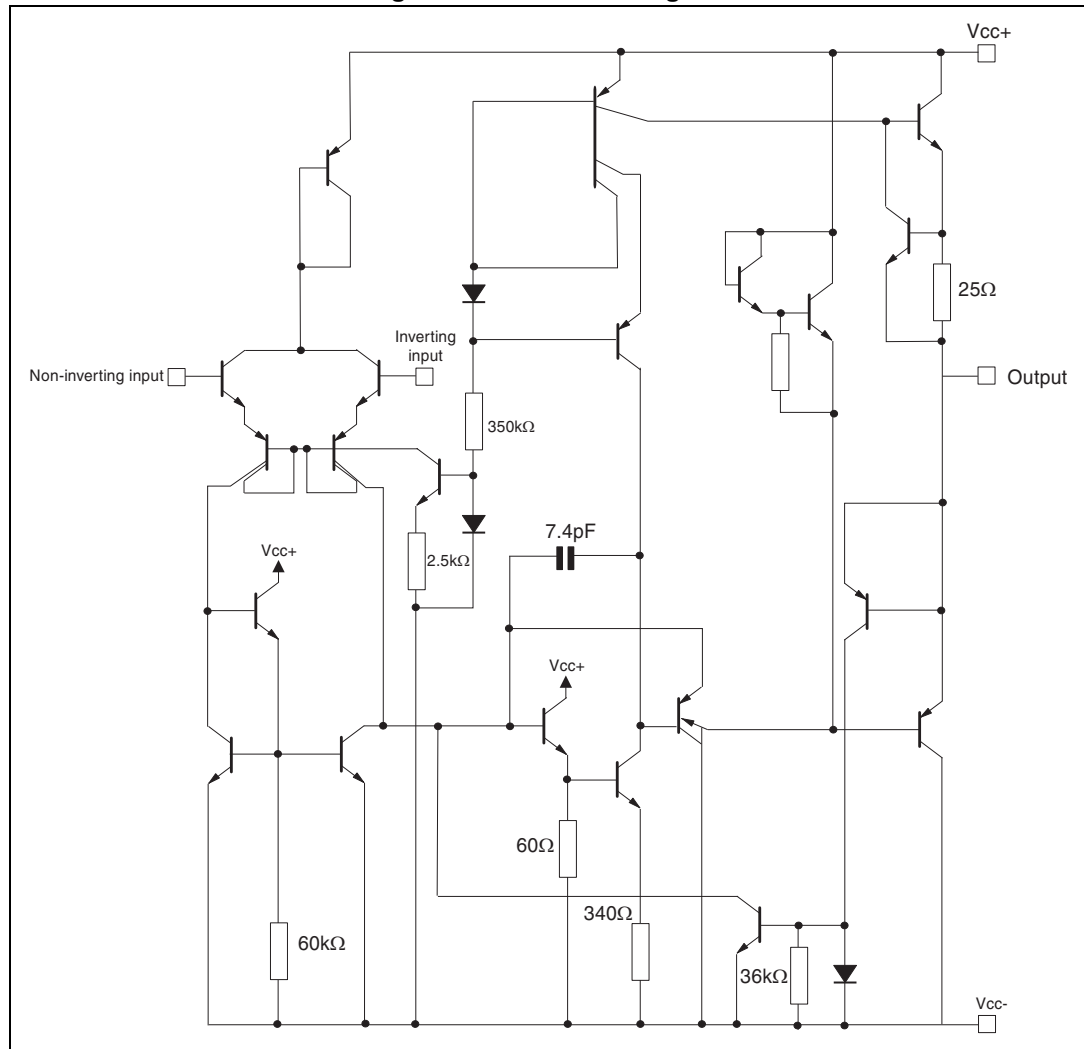

2 Absolute maximum ratings

Table 2. Absolute maximum ratings

Symbol	Parameters	LM248	LM348	Unit
V_{CC}	Supply voltage	±22		V
V_i	Input voltage ⁽¹⁾			
V_{id}	Differential input voltage	±44		
	Output short-circuit duration ⁽²⁾	Infinite		-
P_{tot}	Power dissipation	500		mW
T_{oper}	Operating free-air temperature range	-40 to 105	0 to 70 C	°C
T_{stg}	Storage temperature range	-65 to 150		
ESD	HBM: human body model ⁽³⁾	200		V
	MM: machine model ⁽⁴⁾	50		
	CDM: charged device model ⁽⁵⁾	1.5		kV

1. For supply voltages less than the maximum value, the absolute maximum input voltage is equal to the supply voltage.
2. Any of the amplifier outputs can be shorted to ground indefinitely, however, more than one should not be simultaneously shorted as the maximum junction will be exceeded.
3. Human body model: 100pF discharged through a 1.5kΩ resistor between two pins of the device, done for all couples of pin combinations with other pins floating.
4. Machine model: a 200pF cap is charged to the specified voltage, then discharged directly between two pins of the device with no external series resistor (internal resistor < 5Ω), done for all couples of pin combinations with other pins floating.
5. Charged device model: all pins plus package are charged together to the specified voltage and then discharged directly to the ground.

3 Electrical characteristics

**Table 3. Electrical performances at $V_{CC} = \pm 15\text{ V}$, $T_{amb} = 25\text{ }^{\circ}\text{C}$
(unless otherwise specified)**

Symbol	Parameter	Min.	Typ.	Max.	Unit
V_{io}	Input offset voltage ($R_s \leq 10\text{ k}\Omega$), $T_{amb} = 25\text{ }^{\circ}\text{C}$		1	5	mV
	Input offset voltage ($R_s \leq 10\text{ k}\Omega$), $T_{min} \leq T_{amb} \leq T_{max}$			6	
I_{io}	Input offset current, $T_{amb} = 25\text{ }^{\circ}\text{C}$		2	25	nA
	Input offset current, $T_{min} \leq T_{amb} \leq T_{max}$			75	
I_{ib}	Input bias current, $T_{amb} = 25\text{ }^{\circ}\text{C}$		30	100	nA
	Input bias current, $T_{min} \leq T_{amb} \leq T_{max}$			300	
A_{vd}	Large signal voltage gain ($V_o = \pm 10\text{ V}$, $R_L = 2\text{ k}\Omega$), $T_{amb} = 25\text{ }^{\circ}\text{C}$	50	160		V/mV
	Large signal voltage gain ($V_o = \pm 10\text{ V}$, $R_L = 2\text{ k}\Omega$), $T_{min} \leq T_{amb} \leq T_{max}$	25			
SVR	Supply voltage rejection ratio ($R_s \leq 10\text{ k}\Omega$), $T_{amb} = 25\text{ }^{\circ}\text{C}$	77	100		dB
	Supply voltage rejection ratio ($R_s \leq 10\text{ k}\Omega$), $T_{min} \leq T_{amb} \leq T_{max}$				
I_{cc}	Supply current, all amp, no load, $T_{amb} = 25\text{ }^{\circ}\text{C}$		2.1	3.6	mA
	Supply current, all amp, no load, $T_{min} \leq T_{amb} \leq T_{max}$			4.8	
V_{icm}	Input common mode voltage range, $T_{amb} = 25\text{ }^{\circ}\text{C}$	± 12			V
	Input common mode voltage range, $T_{min} \leq T_{amb} \leq T_{max}$				
CMR	Common mode rejection ratio ($R_s \leq 10\text{ k}\Omega$), $T_{amb} = 25\text{ }^{\circ}\text{C}$	70	110		dB
	Common mode rejection ratio ($R_s \leq 10\text{ k}\Omega$), $T_{min} \leq T_{amb} \leq T_{max}$				
I_{os}	Output short-circuit current, $T_{amb} = 25\text{ }^{\circ}\text{C}$	10	25	35	mA
$\pm V_{opp}$	Output voltage swing, $T_{amb} = 25\text{ }^{\circ}\text{C}$, $R_L \leq 10\text{ k}\Omega$	12	13		V
	Output voltage swing, $T_{amb} = 25\text{ }^{\circ}\text{C}$, $R_L \leq 2\text{ k}\Omega$	10	12		
	Output voltage swing, $T_{min} \leq T_{amb} \leq T_{max}$, $R_L \leq 10\text{ k}\Omega$	12			
	Output voltage swing, $T_{min} \leq T_{amb} \leq T_{max}$, $R_L \leq 2\text{ k}\Omega$	10			
SR	Slew rate ($V_I = \pm 10\text{ V}$, $R_L = 10\text{ k}\Omega$, $C_L = 100\text{ pF}$, unity gain)	0.25	0.5		V/ μs

**Table 3. Electrical performances at $V_{CC} = \pm 15\text{ V}$, $T_{amb} = 25\text{ }^\circ\text{C}$
(unless otherwise specified) (continued)**

Symbol	Parameter	Min.	Typ.	Max.	Unit
t_r	Rise time ($V_I = \pm 10\text{ V}$, $R_L = 10\text{ k}\Omega$, $C_L = 100\text{ pF}$, unity gain)		0.3		μs
K_{OV}	Overshoot ($V_I = \pm 10\text{ V}$, $R_L = 10\text{ k}\Omega$, $C_L = 100\text{ pF}$, unity gain)		5		%
R_I	Input resistance	0.8	2.5		$\text{M}\Omega$
GBP	Gain bandwidth product ($V_I = 10\text{ mV}$, $R_L = 10\text{ k}\Omega$, $C_L = 100\text{ pF}$, $f = 100\text{ kHz}$)	0.7	1.3		MHz
THD	Total harmonic distortion ($f = 1\text{ kHz}$, $A_v = 20\text{ dB}$, $R_L = 10\text{ k}\Omega$, $C_L = 100\text{ pF}$, $V_o = 2\text{ V}_{pp}$)		0.08		%
e_n	Equivalent Input noise voltage ($f = 1\text{ kHz}$, $R_S = 100\text{ }\Omega$)		40		$\frac{\text{nV}}{\sqrt{\text{Hz}}}$
V_{O1}/V_{O2}	Channel separation		120		dB

4 Package information

In order to meet environmental requirements, ST offers these devices in different grades of ECOPACK® packages, depending on their level of environmental compliance. ECOPACK® specifications, grade definitions and product status are available at: www.st.com. ECOPACK® is an ST trademark.

4.1 SO14 package information

Figure 2. SO14 package mechanical drawing

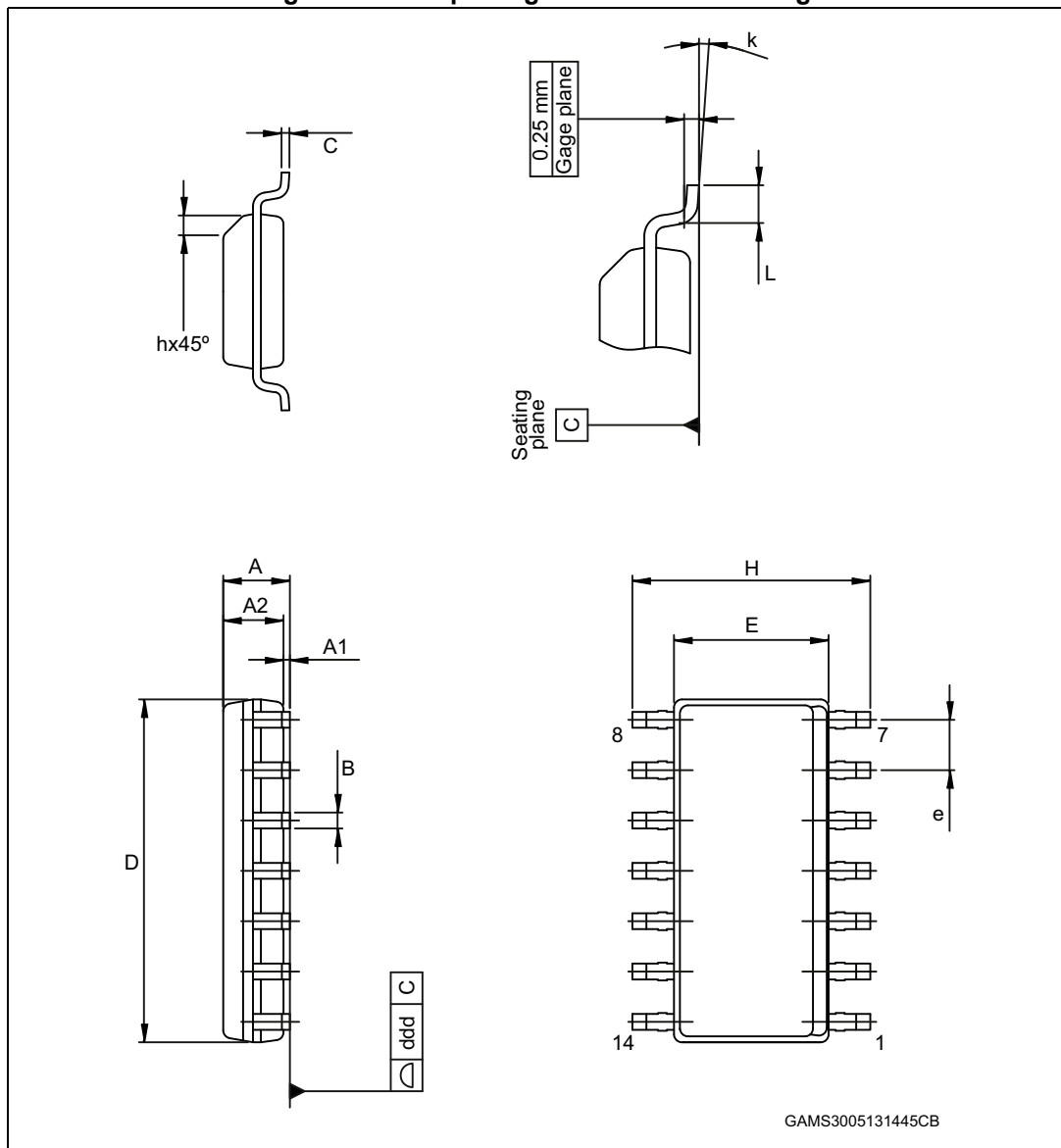

Table 4. SO14 package mechanical data

Ref	Dimensions					
	Millimeters			Inches		
	Min.	Typ.	Max.	Min.	Typ.	Max.
A	1.35		1.75	0.053		0.069
A1	0.10		0.25	0.004		0.010
A2	1.10		1.65	0.043		0.065
B	0.33		0.51	0.013		0.020
C	0.19		0.25	0.007		0.010
D ⁽¹⁾	8.55		8.75	0.337		0.344
E	3.80		4.00	0.150		0.157
e	1.27			0.050		
H	5.80		6.20	0.228		0.244
h	0.25		0.50	0.010		0.020
L	0.40		1.27	0.016		0.050
k	0		8	0		0.315
ddd			0.10			0.004

1. Dimension "D" does not include mold flash, protrusions, or gate burrs. Mold flash, protrusions or gate burrs should not exceed 0.15 mm per side.

5 Ordering information

Table 5. Order codes

Order code	Temperature range	Package	Packaging	Marking
LM248D	-40 °C to 105 °C	SO14	Tube	248
LM248DT			Tape and reel	
LM348DT	0 °C to 70° C	SO14	Tape and reel	348

6 Revision history

Table 6. Document revision history

Date	Revision	Changes
05-Jun-2013	4	<p><i>Description</i>: small text changes</p> <p><i>Table 1: Device summary</i>: updated layout</p> <p>Replaced <i>Figure 2: DIP14 package mechanical drawing</i>, <i>Figure 2: SO14 package mechanical drawing</i>, <i>Table 4: DIP14 package mechanical data</i>, and <i>Table 4: SO14 package mechanical data</i>.</p> <p>Added <i>Section 5: Ordering information</i></p>
06-Dec-2013	5	<p>Removed LM148 - product obsolete</p> <p>Removed DIP14 package (not recommended for new design) and order codes relating to it (LM148N, LM348N).</p> <p><i>Table 2: Absolute maximum ratings</i>: added ESD data</p>

Please Read Carefully:

Information in this document is provided solely in connection with ST products. STMicroelectronics NV and its subsidiaries ("ST") reserve the right to make changes, corrections, modifications or improvements, to this document, and the products and services described herein at any time, without notice.

All ST products are sold pursuant to ST's terms and conditions of sale.

Purchasers are solely responsible for the choice, selection and use of the ST products and services described herein, and ST assumes no liability whatsoever relating to the choice, selection or use of the ST products and services described herein.

No license, express or implied, by estoppel or otherwise, to any intellectual property rights is granted under this document. If any part of this document refers to any third party products or services it shall not be deemed a license grant by ST for the use of such third party products or services, or any intellectual property contained therein or considered as a warranty covering the use in any manner whatsoever of such third party products or services or any intellectual property contained therein.

UNLESS OTHERWISE SET FORTH IN ST'S TERMS AND CONDITIONS OF SALE ST DISCLAIMS ANY EXPRESS OR IMPLIED WARRANTY WITH RESPECT TO THE USE AND/OR SALE OF ST PRODUCTS INCLUDING WITHOUT LIMITATION IMPLIED WARRANTIES OF MERCHANTABILITY, FITNESS FOR A PARTICULAR PURPOSE (AND THEIR EQUIVALENTS UNDER THE LAWS OF ANY JURISDICTION), OR INFRINGEMENT OF ANY PATENT, COPYRIGHT OR OTHER INTELLECTUAL PROPERTY RIGHT.

ST PRODUCTS ARE NOT DESIGNED OR AUTHORIZED FOR USE IN: (A) SAFETY CRITICAL APPLICATIONS SUCH AS LIFE SUPPORTING, ACTIVE IMPLANTED DEVICES OR SYSTEMS WITH PRODUCT FUNCTIONAL SAFETY REQUIREMENTS; (B) AERONAUTIC APPLICATIONS; (C) AUTOMOTIVE APPLICATIONS OR ENVIRONMENTS, AND/OR (D) AEROSPACE APPLICATIONS OR ENVIRONMENTS. WHERE ST PRODUCTS ARE NOT DESIGNED FOR SUCH USE, THE PURCHASER SHALL USE PRODUCTS AT PURCHASER'S SOLE RISK, EVEN IF ST HAS BEEN INFORMED IN WRITING OF SUCH USAGE, UNLESS A PRODUCT IS EXPRESSLY DESIGNATED BY ST AS BEING INTENDED FOR "AUTOMOTIVE, AUTOMOTIVE SAFETY OR MEDICAL" INDUSTRY DOMAINS ACCORDING TO ST PRODUCT DESIGN SPECIFICATIONS. PRODUCTS FORMALLY ESCC, QML OR JAN QUALIFIED ARE DEEMED SUITABLE FOR USE IN AEROSPACE BY THE CORRESPONDING GOVERNMENTAL AGENCY.

Resale of ST products with provisions different from the statements and/or technical features set forth in this document shall immediately void any warranty granted by ST for the ST product or service described herein and shall not create or extend in any manner whatsoever, any liability of ST.

ST and the ST logo are trademarks or registered trademarks of ST in various countries.

Information in this document supersedes and replaces all information previously supplied.

The ST logo is a registered trademark of STMicroelectronics. All other names are the property of their respective owners.

© 2013 STMicroelectronics - All rights reserved

STMicroelectronics group of companies

Australia - Belgium - Brazil - Canada - China - Czech Republic - Finland - France - Germany - Hong Kong - India - Israel - Italy - Japan - Malaysia - Malta - Morocco - Philippines - Singapore - Spain - Sweden - Switzerland - United Kingdom - United States of America

www.st.com