



Chipsmall Limited consists of a professional team with an average of over 10 year of expertise in the distribution of electronic components. Based in Hongkong, we have already established firm and mutual-benefit business relationships with customers from,Europe,America and south Asia,supplying obsolete and hard-to-find components to meet their specific needs.

With the principle of “Quality Parts,Customers Priority,Honest Operation,and Considerate Service”,our business mainly focus on the distribution of electronic components. Line cards we deal with include Microchip,ALPS,ROHM,Xilinx,Pulse,ON,Everlight and Freescale. Main products comprise IC,Modules,Potentiometer,IC Socket,Relay,Connector.Our parts cover such applications as commercial,industrial, and automotives areas.

We are looking forward to setting up business relationship with you and hope to provide you with the best service and solution. Let us make a better world for our industry!



Contact us

Tel: +86-755-8981 8866 Fax: +86-755-8427 6832

Email & Skype: info@chipsmall.com Web: www.chipsmall.com

Address: A1208, Overseas Decoration Building, #122 Zhenhua RD., Futian, Shenzhen, China



LM211, LM311

Single Comparators

The ability to operate from a single power supply of 5.0 V to 30 V or ± 15 V split supplies, as commonly used with operational amplifiers, makes the LM211/LM311 a truly versatile comparator. Moreover, the inputs of the device can be isolated from system ground while the output can drive loads referenced either to ground, the V_{CC} or the V_{EE} supply. This flexibility makes it possible to drive DTL, RTL, TTL, or MOS logic. The output can also switch voltages to 50 V at currents to 50 mA, therefore, the LM211/LM311 can be used to drive relays, lamps or solenoids.

Features

- These Devices are Pb-Free and are RoHS Compliant

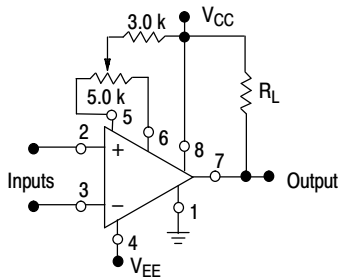

Split Power Supply with Offset Balance

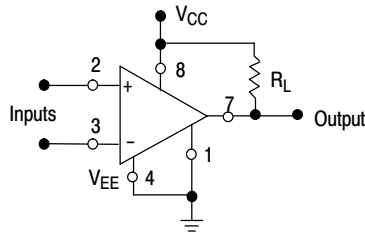

Single Supply

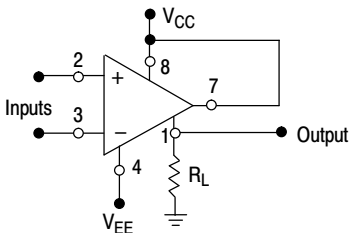

Input polarity is reversed when GND pin is used as an output.

Ground-Referred Load

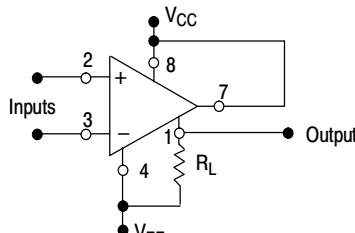

Input polarity is reversed when GND pin is used as an output.

Load Referred to Negative Supply

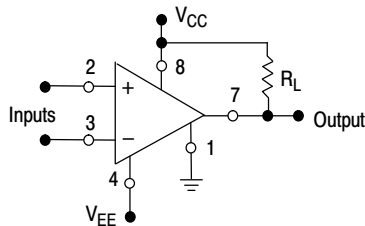

Load Referred to Positive Supply

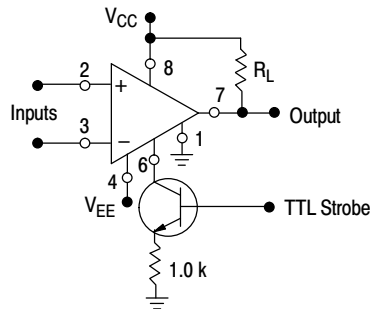

Strobe Capability

Figure 1. Typical Comparator Design Configurations



ON Semiconductor®

<http://onsemi.com>

MARKING DIAGRAMS

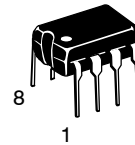

PDIP-8
N SUFFIX
CASE 626

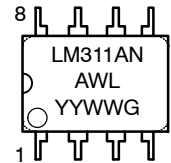

SOIC-8
D SUFFIX
CASE 751

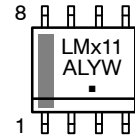

- x = 2 or 3
- A = Assembly Location
- WL, L = Wafer Lot
- YY, Y = Year
- WW, W = Work Week
- G = Pb-Free Package
- = Pb-Free Package

PIN CONNECTIONS

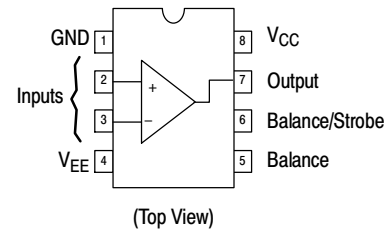

ORDERING INFORMATION

See detailed ordering and shipping information in the package dimensions section on page 2 of this data sheet.

LM211, LM311

ORDERING INFORMATION

Device	Package	Shipping†
LM211DG	SOIC-8 (Pb-Free)	98 Units / Rail
LM211DR2G		2500 Units / Tape & Reel
LM311DG		98 Units / Rail
LM311DR2G		2500 Units / Tape & Reel
LM311NG	PDIP-8 (Pb-Free)	50 Units / Rail

†For information on tape and reel specifications, including part orientation and tape sizes, please refer to our Tape and Reel Packaging Specifications Brochure, BRD8011/D.

MAXIMUM RATINGS (T_A = +25°C, unless otherwise noted.)

Rating	Symbol	LM211	LM311	Unit
Total Supply Voltage	$V_{CC} + V_{EE} $	36	36	Vdc
Output to Negative Supply Voltage	$V_O - V_{EE}$	50	40	Vdc
Ground to Negative Supply Voltage	V_{EE}	30	30	Vdc
Input Differential Voltage	V_{ID}	±30	±30	Vdc
Input Voltage (Note 2)	V_{in}	±15	±15	Vdc
Voltage at Strobe Pin	-	V_{CC} to $V_{CC}-5$	V_{CC} to $V_{CC}-5$	Vdc
Power Dissipation and Thermal Characteristics Plastic DIP Derate Above T _A = +25°C	P_D $R_{\theta JA}$	625 5.0		mW mW/°C
Operating Ambient Temperature Range	T _A	-25 to +85	0 to +70	°C
Operating Junction Temperature	T _{J(max)}	+150	+150	°C
Storage Temperature Range	T _{stg}	-65 to +150	-65 to +150	°C

Stresses exceeding Maximum Ratings may damage the device. Maximum Ratings are stress ratings only. Functional operation above the Recommended Operating Conditions is not implied. Extended exposure to stresses above the Recommended Operating Conditions may affect device reliability.

LM211, LM311

ELECTRICAL CHARACTERISTICS ($V_{CC} = +15\text{ V}$, $V_{EE} = -15\text{ V}$, $T_A = 25^\circ\text{C}$, unless otherwise noted) Note 1

Characteristic	Symbol	LM211			LM311			Unit
		Min	Typ	Max	Min	Typ	Max	
Input Offset Voltage (Note 3) $R_S \leq 50\text{ k}\Omega$, $T_A = +25^\circ\text{C}$ $R_S \leq 50\text{ k}\Omega$, $T_{\text{low}} \leq T_A \leq T_{\text{high}}^*$	V_{IO}	-	0.7	3.0	-	2.0	7.5	mV
Input Offset Current (Note 3) $T_A = +25^\circ\text{C}$ $T_{\text{low}} \leq T_A \leq T_{\text{high}}^*$	I_{IO}	-	1.7	10	-	1.7	50	nA
Input Bias Current $T_A = +25^\circ\text{C}$ $T_{\text{low}} \leq T_A \leq T_{\text{high}}^*$	I_{IB}	-	45	100	-	45	250	nA
Voltage Gain	A_V	40	200	-	40	200	-	V/mV
Response Time (Note 4)		-	200	-	-	200	-	ns
Saturation Voltage $V_{ID} \leq -5.0\text{ mV}$, $I_O = 50\text{ mA}$, $T_A = 25^\circ\text{C}$ $V_{ID} \leq -10\text{ mV}$, $I_O = 50\text{ mA}$, $T_A = 25^\circ\text{C}$ $V_{CC} \geq 4.5\text{ V}$, $V_{EE} = 0$, $T_{\text{low}} \leq T_A \leq T_{\text{high}}^*$ $V_{ID} \leq 6.0\text{ mV}$, $I_{\text{sink}} \leq 8.0\text{ mA}$ $V_{ID} \leq 10\text{ mV}$, $I_{\text{sink}} \leq 8.0\text{ mA}$	V_{OL}	-	0.75	1.5	-	-	-	V
Strobe "On" Current (Note 5)	I_S	-	3.0	-	-	3.0	-	mA
Output Leakage Current $V_{ID} \geq 5.0\text{ mV}$, $V_O = 35\text{ V}$, $T_A = 25^\circ\text{C}$, $I_{\text{strobe}} = 3.0\text{ mA}$ $V_{ID} \geq 10\text{ mV}$, $V_O = 35\text{ V}$, $T_A = 25^\circ\text{C}$, $I_{\text{strobe}} = 3.0\text{ mA}$ $V_{ID} \geq 5.0\text{ mV}$, $V_O = 35\text{ V}$, $T_{\text{low}} \leq T_A \leq T_{\text{high}}^*$		-	0.2	10	-	-	-	nA
		-	-	-	-	0.2	50	nA
		-	0.1	0.5	-	-	-	μA
Input Voltage Range ($T_{\text{low}} \leq T_A \leq T_{\text{high}}^*$)	V_{ICR}	-14.5	-14.7 to 13.8	+13.0	-14.5	-14.7 to 13.8	+13.0	V
Positive Supply Current	I_{CC}	-	+2.4	+6.0	-	+2.4	+7.5	mA
Negative Supply Current	I_{EE}	-	-1.3	-5.0	-	-1.3	-5.0	mA

* LM211: $T_{\text{low}} = -25^\circ\text{C}$, $T_{\text{high}} = +85^\circ\text{C}$

LM311: $T_{\text{low}} = 0^\circ\text{C}$, $T_{\text{high}} = +70^\circ\text{C}$

- Offset voltage, offset current and bias current specifications apply for a supply voltage range from a single 5.0 V supply up to $\pm 15\text{ V}$ supplies.
- This rating applies for $\pm 15\text{ V}$ supplies. The positive input voltage limit is 30 V above the negative supply. The negative input voltage limit is equal to the negative supply voltage or 30 V below the positive supply, whichever is less.
- The offset voltages and offset currents given are the maximum values required to drive the output within a volt of either supply with a 1.0 mA load. Thus, these parameters define an error band and take into account the "worst case" effects of voltage gain and input impedance.
- The response time specified is for a 100 mV input step with 5.0 mV overdrive.
- Do not short the strobe pin to ground; it should be current driven at 3.0 mA to 5.0 mA.

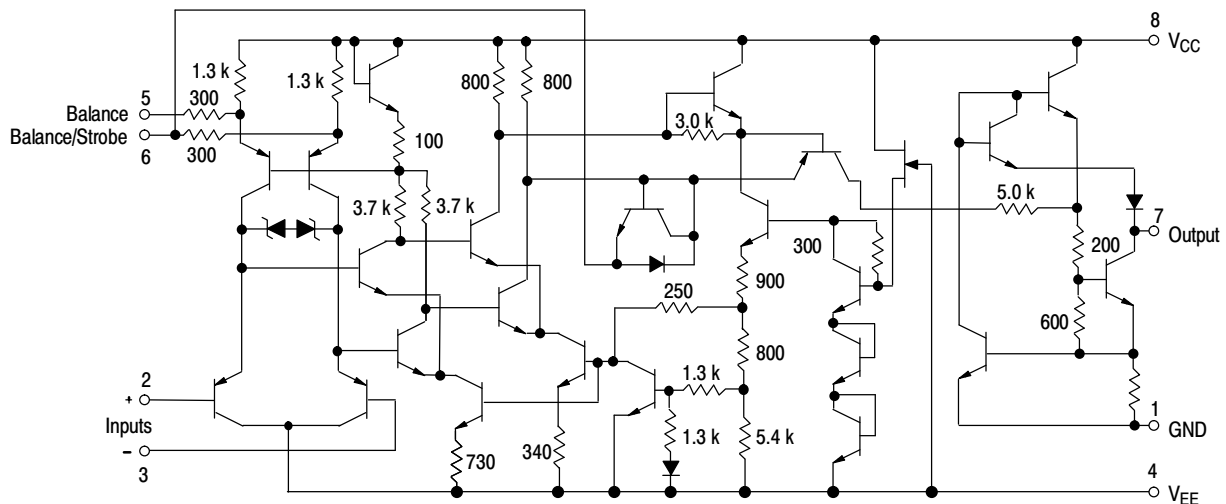

Figure 2. Circuit Schematic

LM211, LM311

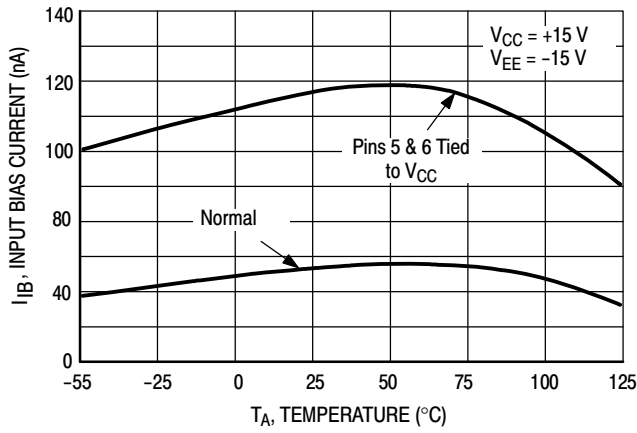

Figure 3. Input Bias Current versus Temperature

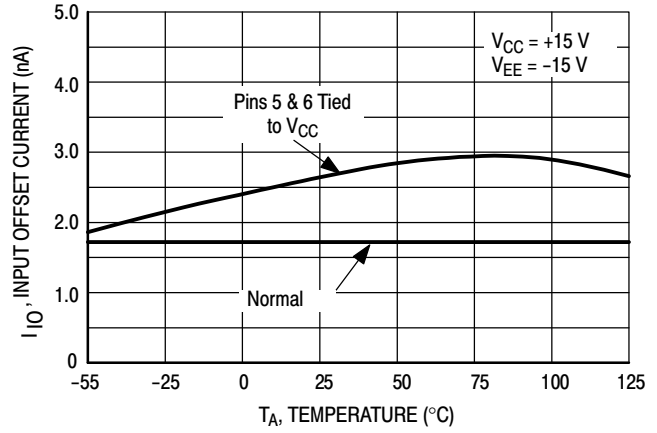

Figure 4. Input Offset Current versus Temperature

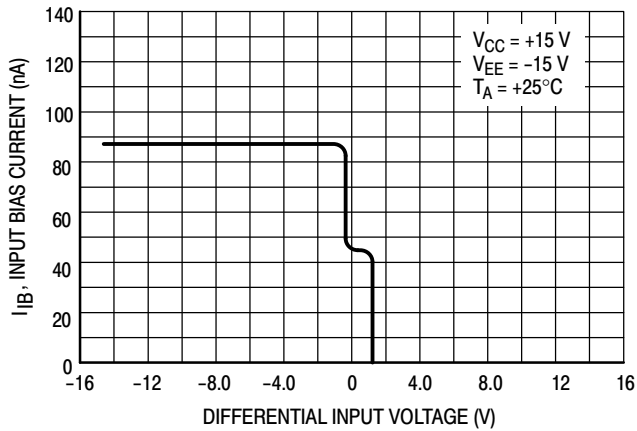

Figure 5. Input Bias Current versus Differential Input Voltage

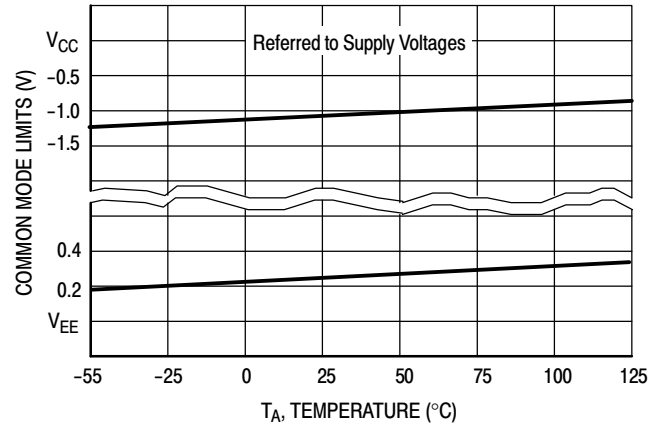

Figure 6. Common Mode Limits versus Temperature

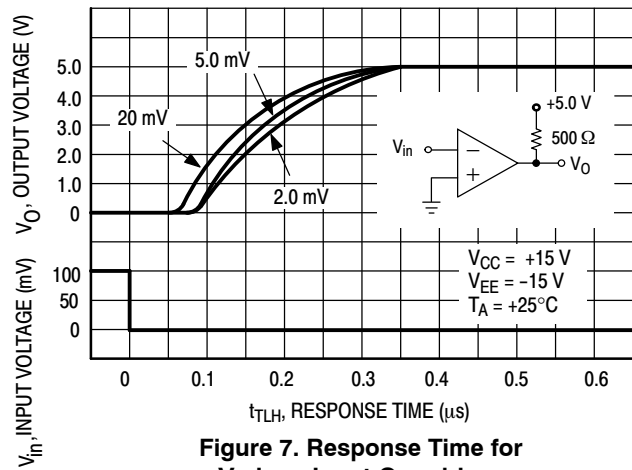

Figure 7. Response Time for Various Input Overdrives

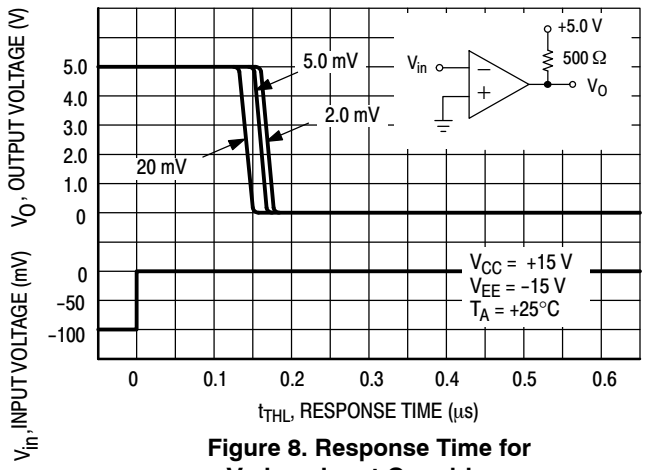

Figure 8. Response Time for Various Input Overdrives

LM211, LM311

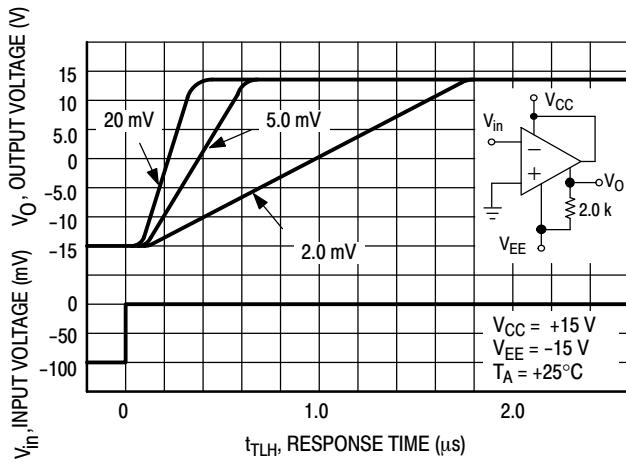

Figure 9. Response Time for Various Input Overdrives

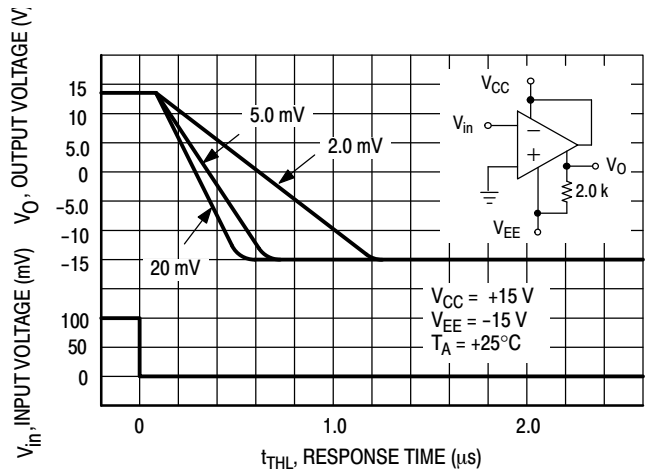

Figure 10. Response Time for Various Input Overdrives

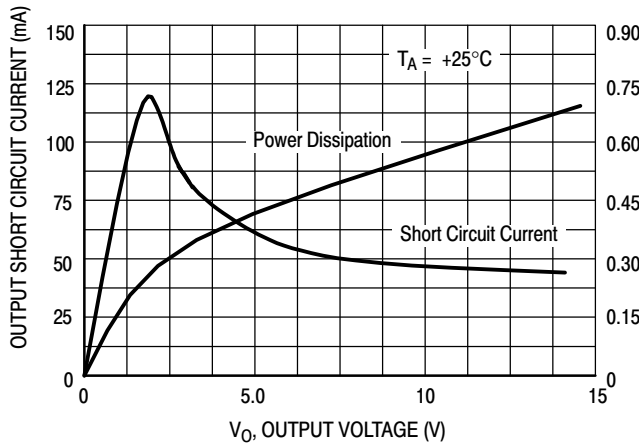

Figure 11. Output Short Circuit Current Characteristics and Power Dissipation

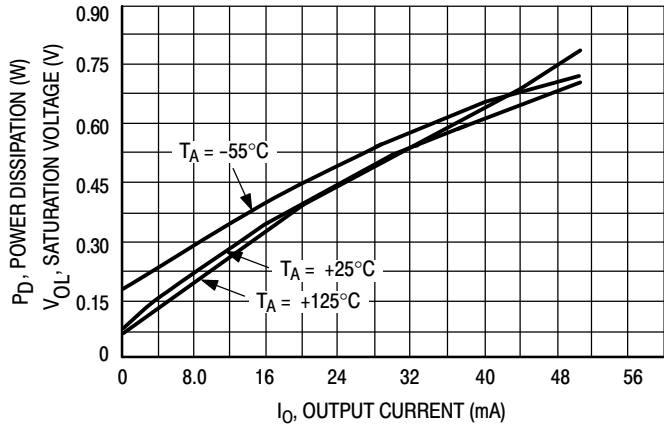

Figure 12. Output Saturation Voltage versus Output Current

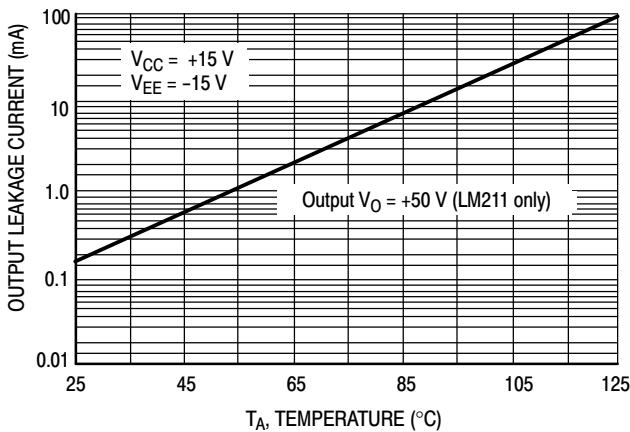

Figure 13. Output Leakage Current versus Temperature

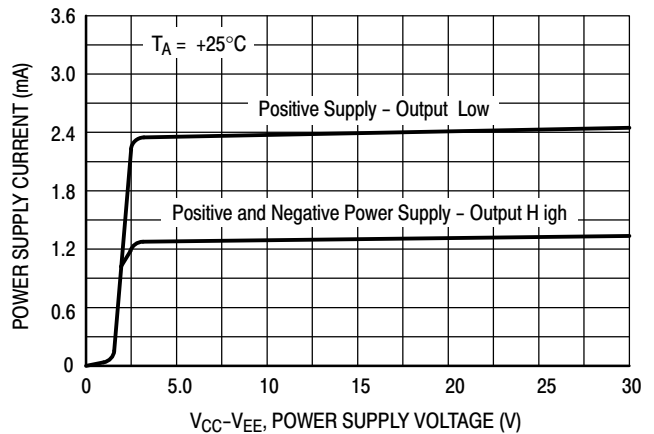

Figure 14. Power Supply Current versus Supply Voltage

LM211, LM311

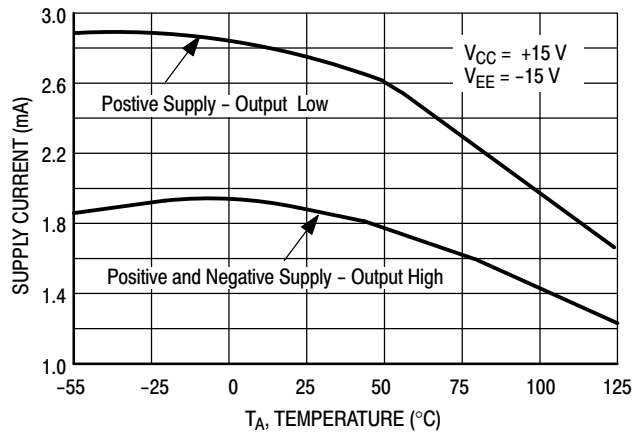

Figure 15. Power Supply Current versus Temperature

APPLICATIONS INFORMATION

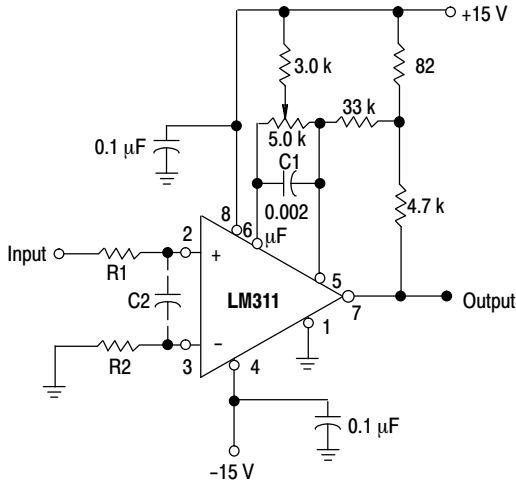

Figure 16. Improved Method of Adding Hysteresis Without Applying Positive Feedback to the Inputs

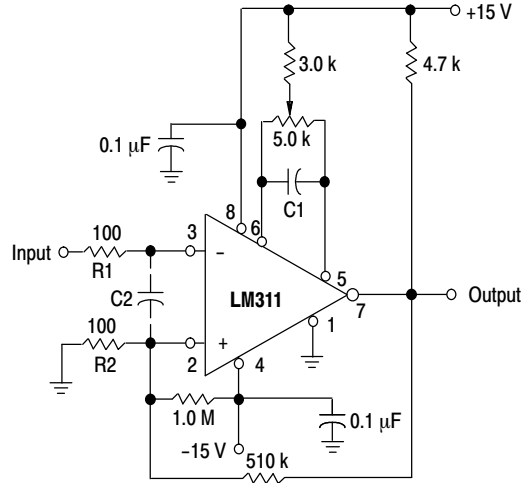

Figure 17. Conventional Technique for Adding Hysteresis

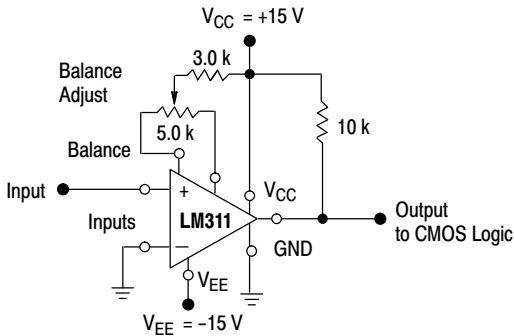

Figure 18. Zero-Crossing Detector Driving CMOS Logic

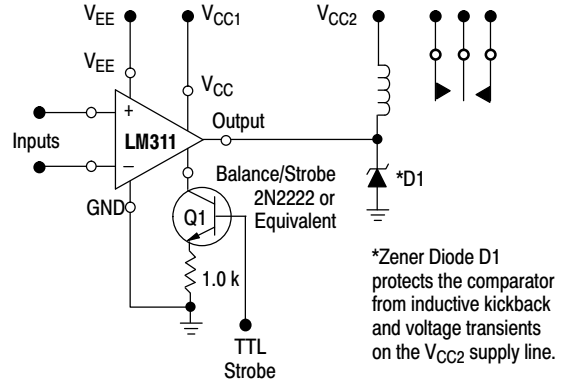

Figure 19. Relay Driver with Strobe Capability

TECHNIQUES FOR AVOIDING OSCILLATIONS IN COMPARATOR APPLICATIONS

When a high speed comparator such as the LM211 is used with high speed input signals and low source impedances, the output response will normally be fast and stable, providing the power supplies have been bypassed (with 0.1 μF disc capacitors), and that the output signal is routed well away from the inputs (Pins 2 and 3) and also away from Pins 5 and 6.

However, when the input signal is a voltage ramp or a slow sine wave, or if the signal source impedance is high (1.0 $\text{k}\Omega$ to 100 $\text{k}\Omega$), the comparator may burst into oscillation near the crossing-point. This is due to the high gain and wide bandwidth of comparators like the LM211 series. To avoid oscillation or instability in such a usage, several precautions are recommended, as shown in Figure 16.

The trim pins (Pins 5 and 6) act as unwanted auxiliary inputs. If these pins are not connected to a trim-pot, they should be shorted together. If they are connected to a trim-pot, a 0.01 μF capacitor (C1) between Pins 5 and 6 will minimize the susceptibility to AC coupling. A smaller capacitor is used if Pin 5 is used for positive feedback as in Figure 16. For the fastest response time, tie both balance pins to V_{CC} .

Certain sources will produce a cleaner comparator output waveform if a 100 pF to 1000 pF capacitor (C2) is connected directly across the input pins. When the signal source is applied through a resistive network, R1, it is usually advantageous to choose R2 of the same value, both for DC and for dynamic (AC) considerations. Carbon, tin-oxide, and metal-film resistors have all been used with good results in comparator input circuitry, but inductive wirewound resistors should be avoided.

When comparator circuits use input resistors (e.g., summing resistors), their value and placement are particularly important. In all cases the body of the resistor should be close to the device or socket. In other words, there should be a very short lead length or printed-circuit foil run between comparator and resistor to radiate or pick up signals. The same applies to capacitors, pots, etc. For example, if R1 = 10 $\text{k}\Omega$, as little as 5 inches of lead between the resistors and the input pins can result in oscillations that are very hard to dampen. Twisting these input leads tightly is the best alternative to placing resistors close to the comparator.

Since feedback to almost any pin of a comparator can result in oscillation, the printed-circuit layout should be engineered thoughtfully. Preferably there should be a groundplane under the LM211 circuitry (e.g., one side of a double layer printed circuit board). Ground, positive supply or negative supply foil should extend between the output and the inputs to act as a guard. The foil connections for the inputs should be as small and compact as possible, and should be essentially surrounded by ground foil on all sides to guard against capacitive coupling from any fast high-level signals (such as the output). If Pins 5 and 6 are not used, they should be shorted together. If they are connected to a trim-pot, the trim-pot should be located no more than a few inches away from the LM211, and a 0.01 μF capacitor should be installed across Pins 5 and 6. If this capacitor cannot be used, a shielding printed-circuit foil may be advisable between Pins 6 and 7. The power supply bypass capacitors should be located within a couple inches of the LM211.

A standard procedure is to add hysteresis to a comparator to prevent oscillation, and to avoid excessive noise on the output. In the circuit of Figure 17, the feedback resistor of 510 $\text{k}\Omega$ from the output to the positive input will cause about 3.0 mV of hysteresis. However, if R2 is larger than 100 Ω , such as 50 $\text{k}\Omega$, it would not be practical to simply increase the value of the positive feedback resistor proportionally above 510 $\text{k}\Omega$ to maintain the same amount of hysteresis.

When both inputs of the LM211 are connected to active signals, or if a high-impedance signal is driving the positive input of the LM211 so that positive feedback would be disruptive, the circuit of Figure 16 is ideal. The positive feedback is applied to Pin 5 (one of the offset adjustment pins). This will be sufficient to cause 1.0 mV to 2.0 mV hysteresis and sharp transitions with input triangle waves from a few Hz to hundreds of kHz. The positive-feedback signal across the 82 Ω resistor swings 240 mV below the positive supply. This signal is centered around the nominal voltage at Pin 5, so this feedback does not add to the offset voltage of the comparator. As much as 8.0 mV of offset voltage can be trimmed out, using the 5.0 $\text{k}\Omega$ pot and 3.0 $\text{k}\Omega$ resistor as shown.

LM211, LM311

PACKAGE DIMENSIONS

PDIP-8
N SUFFIX
CASE 626-05
ISSUE M

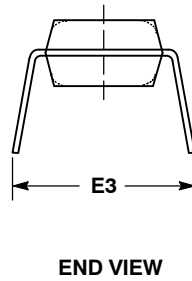
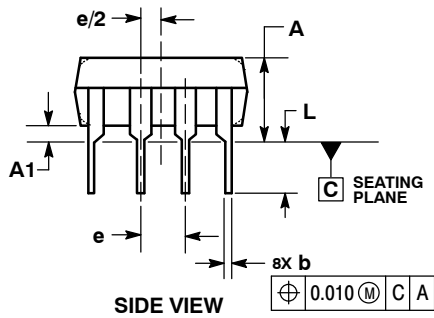
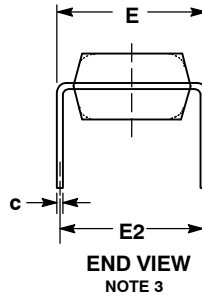
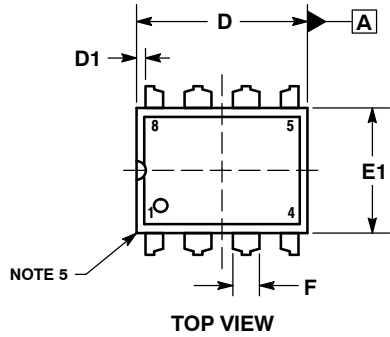

NOTES:

1. DIMENSIONING AND TOLERANCING PER ASME Y14.5M, 1994.
2. CONTROLLING DIMENSION: INCHES.
3. DIMENSION E IS MEASURED WITH THE LEADS RESTRAINED PARALLEL AT WIDTH E2.
4. DIMENSION E1 DOES NOT INCLUDE MOLD FLASH.
5. ROUNDED CORNERS OPTIONAL.

DIM	INCHES			MILLIMETERS		
	MIN	NOM	MAX	MIN	NOM	MAX
A	----	----	0.210	----	----	5.33
A1	0.015	----	----	0.38	----	----
b	0.014	0.018	0.022	0.35	0.46	0.56
C	0.008	0.010	0.014	0.20	0.25	0.36
D	0.355	0.365	0.400	9.02	9.27	10.02
D1	0.005	----	----	0.13	----	----
E	0.300	0.310	0.325	7.62	7.87	8.26
E1	0.240	0.250	0.280	6.10	6.35	7.11
E2	0.300 BSC			7.62 BSC		
E3	0.100 BSC			2.54 BSC		
L	0.115	0.130	0.150	2.92	3.30	3.81

LM211, LM311

PACKAGE DIMENSIONS

SOIC-8
D SUFFIX
CASE 751-07
ISSUE AK

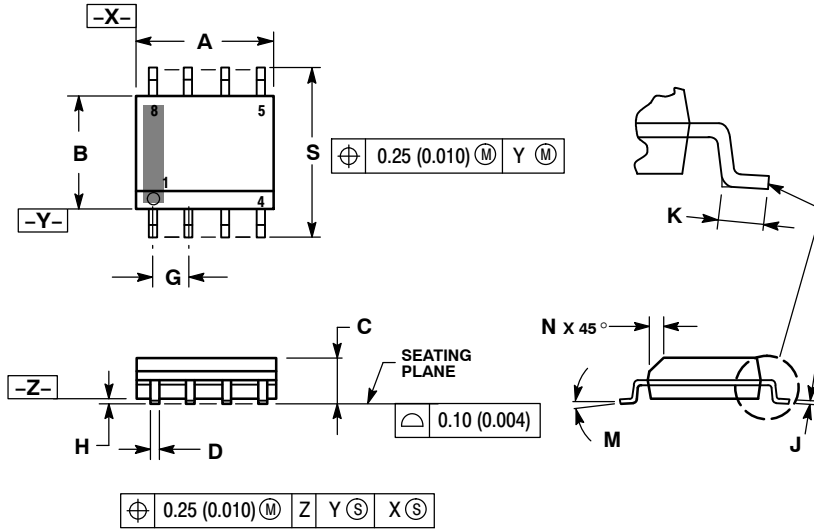

NOTES:

1. DIMENSIONING AND TOLERANCING PER ANSI Y14.5M, 1982.
2. CONTROLLING DIMENSION: MILLIMETER.
3. DIMENSION A AND B DO NOT INCLUDE MOLD PROTRUSION.
4. MAXIMUM MOLD PROTRUSION 0.15 (0.006) PER SIDE.
5. DIMENSION D DOES NOT INCLUDE DAMBAR PROTRUSION. ALLOWABLE DAMBAR PROTRUSION SHALL BE 0.127 (0.005) TOTAL IN EXCESS OF THE D DIMENSION AT MAXIMUM MATERIAL CONDITION.
6. 751-01 THRU 751-06 ARE OBSOLETE. NEW STANDARD IS 751-07.

DIM	MILLIMETERS		INCHES	
	MIN	MAX	MIN	MAX
A	4.80	5.00	0.189	0.197
B	3.80	4.00	0.150	0.157
C	1.35	1.75	0.053	0.069
D	0.33	0.51	0.013	0.020
G	1.27 BSC		0.050 BSC	
H	0.10	0.25	0.004	0.010
J	0.19	0.25	0.007	0.010
K	0.40	1.27	0.016	0.050
M	0 °	8 °	0 °	8 °
N	0.25	0.50	0.010	0.020
S	5.80	6.20	0.228	0.244

SOLDERING FOOTPRINT*

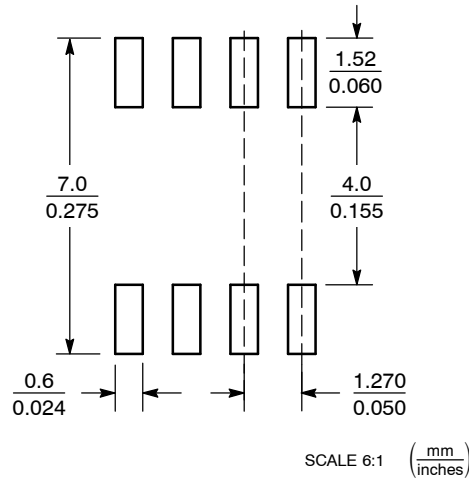

*For additional information on our Pb-Free strategy and soldering details, please download the ON Semiconductor Soldering and Mounting Techniques Reference Manual, SOLDERRM/D.

ON Semiconductor and are registered trademarks of Semiconductor Components Industries, LLC (SCILLC). SCILLC owns the rights to a number of patents, trademarks, copyrights, trade secrets, and other intellectual property. A listing of SCILLC's product/patent coverage may be accessed at www.onsemi.com/site/pdf/Patent-Marking.pdf. SCILLC reserves the right to make changes without further notice to any products herein. SCILLC makes no warranty, representation or guarantee regarding the suitability of its products for any particular purpose, nor does SCILLC assume any liability arising out of the application or use of any product or circuit, and specifically disclaims any and all liability, including without limitation special, consequential or incidental damages. "Typical" parameters which may be provided in SCILLC data sheets and/or specifications can and do vary in different applications and actual performance may vary over time. All operating parameters, including "Typicals" must be validated for each customer application by customer's technical experts. SCILLC does not convey any license under its patent rights nor the rights of others. SCILLC products are not designed, intended, or authorized for use as components in systems intended for surgical implant into the body, or other applications intended to support or sustain life, or for any other application in which the failure of the SCILLC product could create a situation where personal injury or death may occur. Should Buyer purchase or use SCILLC products for any such unintended or unauthorized application, Buyer shall indemnify and hold SCILLC and its officers, employees, subsidiaries, affiliates, and distributors harmless against all claims, costs, damages, and expenses, and reasonable attorney fees arising out of, directly or indirectly, any claim of personal injury or death associated with such unintended or unauthorized use, even if such claim alleges that SCILLC was negligent regarding the design or manufacture of the part. SCILLC is an Equal Opportunity/Affirmative Action Employer. This literature is subject to all applicable copyright laws and is not for resale in any manner.

PUBLICATION ORDERING INFORMATION

LITERATURE FULFILLMENT:
Literature Distribution Center for ON Semiconductor
P.O. Box 5163, Denver, Colorado 80217 USA
Phone: 303-675-2175 or 800-344-3860 Toll Free USA/Canada
Fax: 303-675-2176 or 800-344-3867 Toll Free USA/Canada
Email: orderlit@onsemi.com

N. American Technical Support: 800-282-9855 Toll Free
USA/Canada
Europe, Middle East and Africa Technical Support:
Phone: 421 33 790 2910
Japan Customer Focus Center
Phone: 81-3-5817-1050

ON Semiconductor Website: www.onsemi.com
Order Literature: <http://www.onsemi.com/orderlit>

For additional information, please contact your local Sales Representative