



Chipsmall Limited consists of a professional team with an average of over 10 year of expertise in the distribution of electronic components. Based in Hongkong, we have already established firm and mutual-benefit business relationships with customers from,Europe,America and south Asia,supplying obsolete and hard-to-find components to meet their specific needs.

With the principle of “Quality Parts,Customers Priority,Honest Operation,and Considerate Service”,our business mainly focus on the distribution of electronic components. Line cards we deal with include Microchip,ALPS,ROHM,Xilinx,Pulse,ON,Everlight and Freescale. Main products comprise IC,Modules,Potentiometer,IC Socket,Relay,Connector.Our parts cover such applications as commercial,industrial, and automotives areas.

We are looking forward to setting up business relationship with you and hope to provide you with the best service and solution. Let us make a better world for our industry!



## Contact us

Tel: +86-755-8981 8866 Fax: +86-755-8427 6832

Email & Skype: info@chipsmall.com Web: www.chipsmall.com

Address: A1208, Overseas Decoration Building, #122 Zhenhua RD., Futian, Shenzhen, China





# LM217M LM317M

## MEDIUM CURRENT 1.2 TO 37V ADJUSTABLE VOLTAGE REGULATOR

- OUTPUT VOLTAGE RANGE: 1.2 TO 37V
- OUTPUT CURRENT IN EXCESS OF 500 mA
- LINE REGULATION TYP. 0.01%
- LOAD REGULATION TYP. 0.1%
- THERMAL OVERLOAD PROTECTION
- SHORT CIRCUIT PROTECTION
- OUTPUT TRANSITION SAFE AREA COMPENSATION
- FLOATING OPERATION FOR HIGH VOLTAGE APPLICATIONS

### DESCRIPTION

The LM217M/LM317M are monolithic integrated circuits in TO-220 and DPAK packages intended for use as positive adjustable voltage regulators.

They are designed to supply until 500 mA of load current with an output voltage adjustable over a 1.2 to 37V range.

The nominal output voltage is selected by means of only a resistive divider, making the device exceptionally easy to use and eliminating the stocking of many fixed regulators.

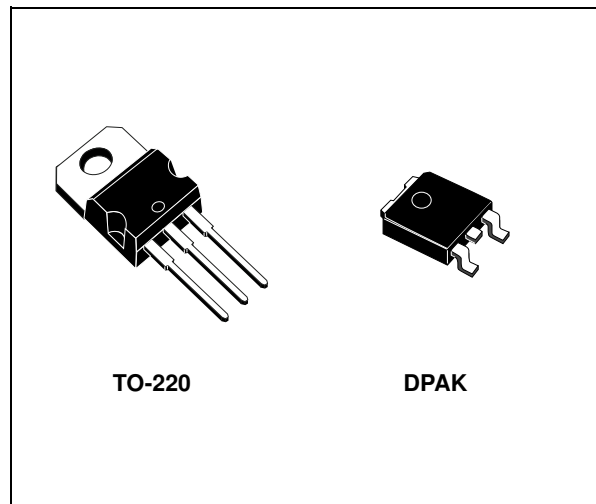

### SCHEMATIC DIAGRAM

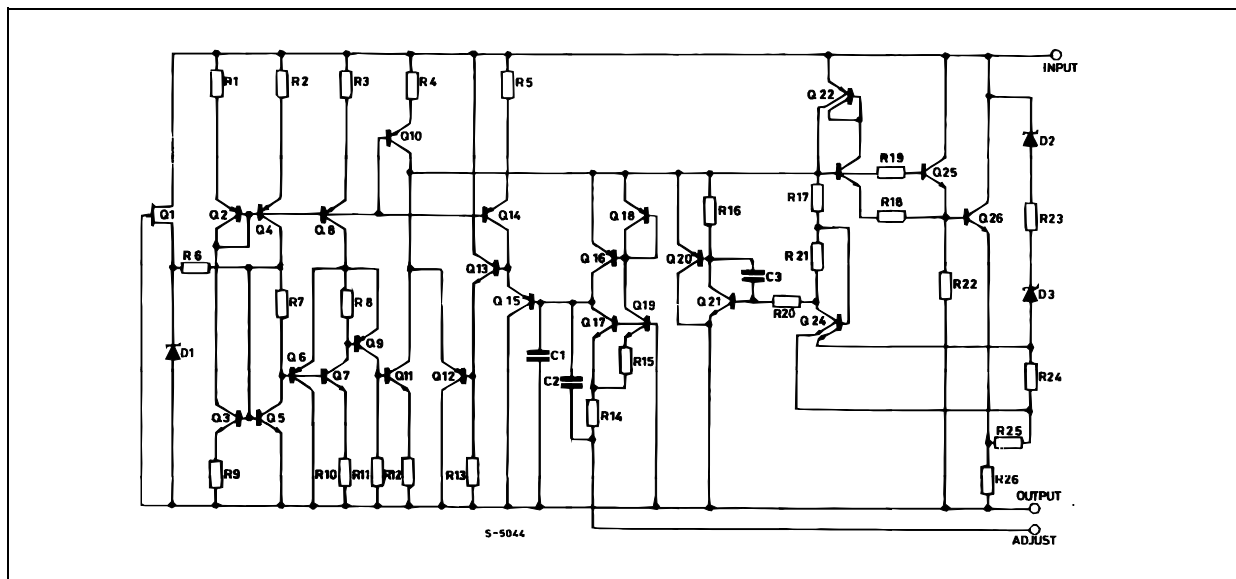

## LM217M/LM317M

### ABSOLUTE MAXIMUM RATINGS

Symbol	Parameter	Value	Unit
$V_I - V_O$	Input-Output Differential Voltage	40	V
$P_d$	Power Dissipation	Internally Limited	
$T_{opr}$	Operating Junction Temperature Range (*)	for LM217M	-40 to 125
		for LM317M	0 to 125
$T_{stg}$	Storage Temperature Range	-55 to 150	°C

(\*) Re-Boot is not guaranteed for  $T_J \geq 85^\circ\text{C}$ .

### THERMAL DATA

Symbol	Parameter		SOT-82 SOT-194 DPAK	TO-220	Unit
$R_{thj-case}$	Thermal Resistance Junction-case	Max	8	3	°C/W
$R_{thj-amb}$	Thermal Resistance Junction-ambient	Max	100	50	°C/W

### CONNECTION DIAGRAM (top view)

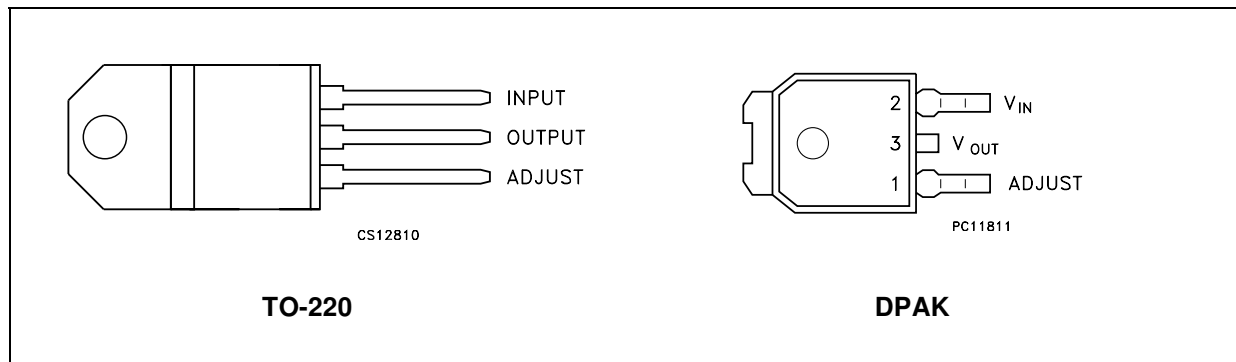

### ORDERING CODES

TYPE	TO-220	DPAK (*)
LM217M	LM217MT	LM217MDT
LM317M	LM317MT	LM317MDT

(\*) Available in Tape & Reel with the suffix "-TR".

### TEST CIRCUIT

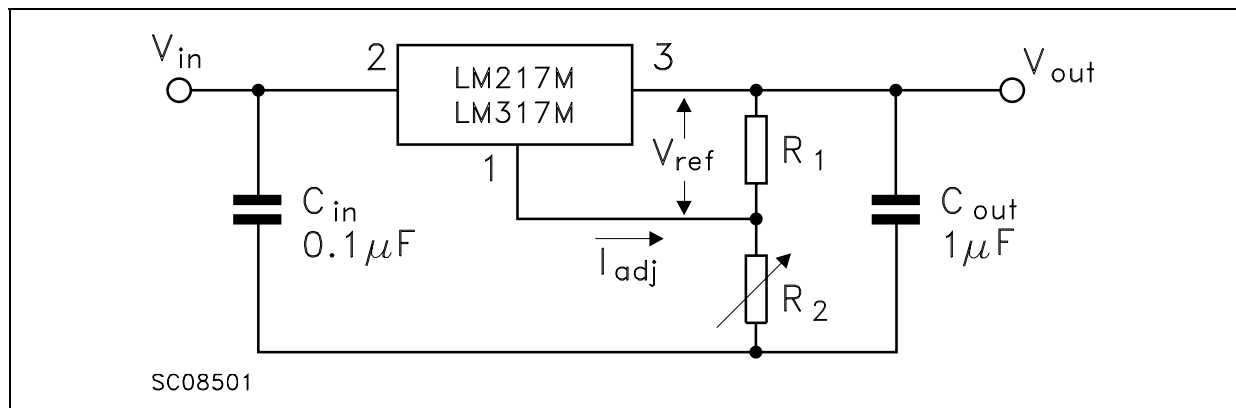

**ELECTRICAL CHARACTERISTICS OF LM217M** (refer to the test circuits,  $T_J = -40$  to  $125^\circ\text{C}$ ,  $V_I - V_O = 5\text{ V}$ ,  $I_O = 100\text{ mA}$ ,  $P_d \leq 7.5\text{ W}$ , unless otherwise specified).

Symbol	Parameter	Test Conditions	Min.	Typ.	Max.	Unit	
$\Delta V_O$	Line Regulation	$V_I - V_O = 3$ to $40\text{ V}$	$T_J = 25^\circ\text{C}$		0.01	0.02	%V
					0.02	0.05	
$\Delta V_O$	Load Regulation	$V_O \leq 5\text{ V}$ $I_O = 10$ to $500\text{ mA}$	$T_J = 25^\circ\text{C}$		5	15	mV
					20	50	
		$V_O \geq 5\text{ V}$ $I_O = 10$ to $500\text{ mA}$	$T_J = 25^\circ\text{C}$		0.1	0.3	%V <sub>O</sub>
					0.3	1	
$I_{ADJ}$	Adjustment Pin Current			50	100	$\mu\text{A}$	
$\Delta I_{ADJ}$	Adjustment Pin Current	$V_I - V_O = 3$ to $40\text{ V}$ $I_O = 10$ to $500\text{ mA}$		0.2	5	$\mu\text{A}$	
$V_{REF}$	Reference Voltage	$V_I - V_O = 3$ to $40\text{ V}$ $I_O = 10$ to $500\text{ mA}$	1.2	1.25	1.3	V	
$\Delta V_O/V_O$	Output Voltage Temperature Stability			0.7		%	
$I_{O(min)}$	Minimum Load Current	$V_I - V_O = 40\text{ V}$		3.5	5	mA	
$I_{O(max)}$	Maximum Output Current	$V_I - V_O \leq 15\text{ V}$	500	1000		mA	
		$V_I - V_O = 40\text{ V}$ , $P_d < P_{dMAX}$ , $T_J = 25^\circ\text{C}$		200			
eN	Output Noise Voltage (percentage of $V_O$ )	$B = 10\text{ Hz}$ to $100\text{ KHz}$ $T_J = 25^\circ\text{C}$		0.003		%	
SVR	Supply Voltage Rejection (*)	$T_J = 25^\circ\text{C}$ $f = 120\text{ Hz}$	$C_{ADJ} = 0$	65		dB	
			$C_{ADJ} = 10\ \mu\text{F}$	66	80		

(\*) CADJ is connected between Adjust pin and Ground.

**ELECTRICAL CHARACTERISTICS OF LM317M** (refer to the test circuits,  $T_J = 0$  to  $125^\circ\text{C}$ ,  $V_I - V_O = 5\text{ V}$ ,  $I_O = 100\text{ mA}$ ,  $P_d \leq 7.5\text{ W}$ , unless otherwise specified).

Symbol	Parameter	Test Conditions	Min.	Typ.	Max.	Unit	
$\Delta V_O$	Line Regulation	$V_I - V_O = 3$ to $40\text{ V}$	$T_J = 25^\circ\text{C}$		0.01	0.04	%V
					0.02	0.07	
$\Delta V_O$	Load Regulation	$V_O \leq 5\text{ V}$ $I_O = 10$ to $500\text{ mA}$	$T_J = 25^\circ\text{C}$		5	25	mV
					20	70	
		$V_O \geq 5\text{ V}$ $I_O = 10$ to $500\text{ mA}$	$T_J = 25^\circ\text{C}$		0.1	0.5	%V <sub>O</sub>
					0.3	1.5	
$I_{ADJ}$	Adjustment Pin Current			50	100	$\mu\text{A}$	
$\Delta I_{ADJ}$	Adjustment Pin Current	$V_I - V_O = 3$ to $40\text{ V}$ $I_O = 10$ to $500\text{ mA}$		0.2	5	$\mu\text{A}$	
$V_{REF}$	Reference Voltage	$V_I - V_O = 3$ to $40\text{ V}$ $I_O = 10$ to $500\text{ mA}$	1.2	1.25	1.3	V	
$\Delta V_O/V_O$	Output Voltage Temperature Stability			0.7		%	
$I_{O(min)}$	Minimum Load Current	$V_I - V_O = 40\text{ V}$		3.5	10	mA	
$I_{O(max)}$	Maximum Output Current	$V_I - V_O \leq 15\text{ V}$	500	1000		mA	
		$V_I - V_O = 40\text{ V}$ , $P_d < P_{dMAX}$ , $T_J = 25^\circ\text{C}$		200			
eN	Output Noise Voltage (percentage of $V_O$ )	$B = 10\text{ Hz}$ to $100\text{ KHz}$ $T_J = 25^\circ\text{C}$		0.003		%	
SVR	Supply Voltage Rejection (*)	$T_J = 25^\circ\text{C}$ $f = 120\text{ Hz}$	$C_{ADJ} = 0$	65		dB	
			$C_{ADJ} = 10\ \mu\text{F}$	66	80		

(\*) CADJ is connected between Adjust pin and Ground.

Figure 1 : Current Limit

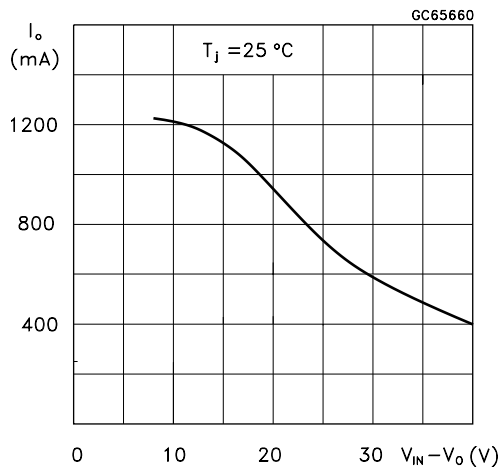

Figure 2 : Minimum Operating Current

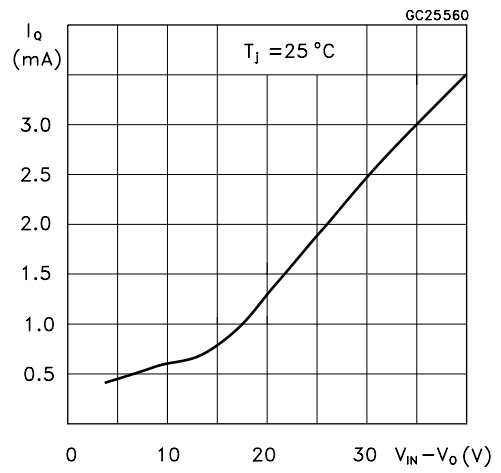

Figure 3 : Basic Adjustable Regulator

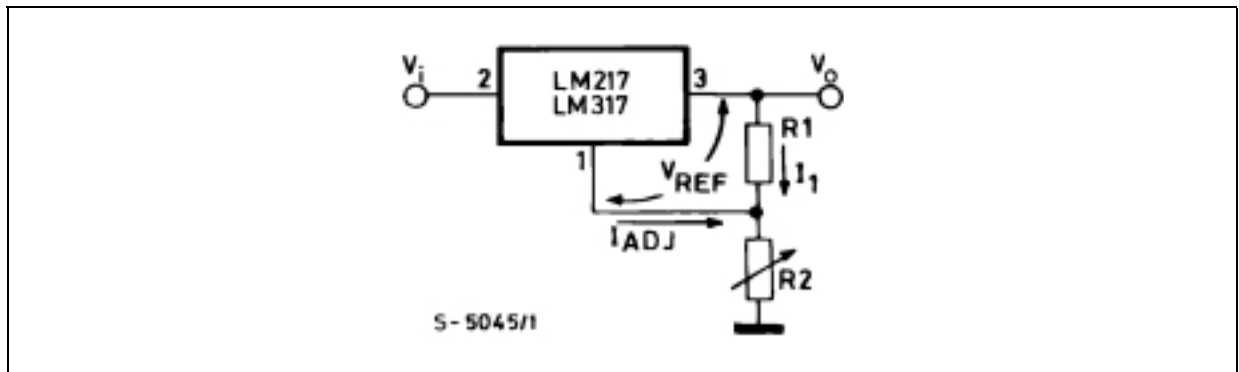
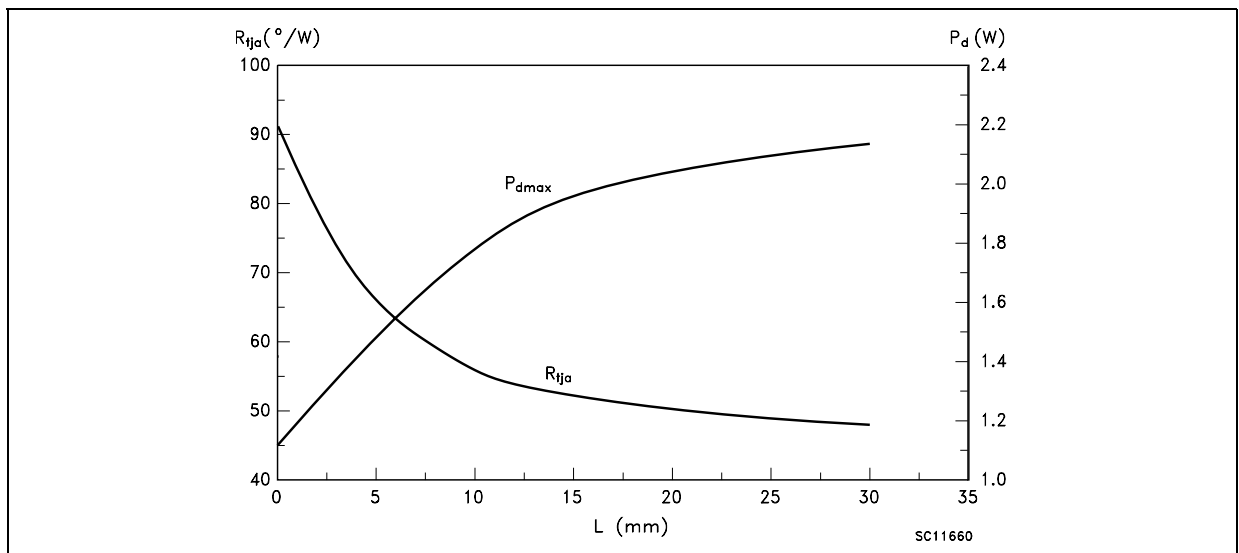

Figure 4 : Thermal Resistance & Maximum Power Dissipation vs P.C.B. Copper Length for DPAK



$P_{dmax}$  calculated for  $T_a = 50^{\circ}C$ .

### APPLICATION INFORMATION

The LM217M/LM317M provide an internal reference voltage of 1.25V between the output and adjustment terminals. These devices are used to set a constant current flow across an external resistor divider (see fig. 3), giving an output voltage  $V_O$  of:  $V_O = V_{REF} (1 + R_2 / R_1) + I_{ADJ} R_2$

The devices were designed to minimize the term  $I_{ADJ}$  (100 $\mu$ A max) and to maintain it very constant in line and load changes. Usually, the error term  $I_{ADJ} \times R_2$  can be neglected. To obtain the previous requirement, all the regulator quiescent current is returned to the output terminal, imposing a minimum load current condition. If the load is insufficient, the output voltage will rise.

Since the LM217M/LM317M devices are floating regulators and "see" only the input-to-output differential voltage, supplies of very high voltage with respect to ground can be regulated as long as the maximum input-to-output differential is not exceeded. Furthermore, programmable regulators are easily obtained and, by connecting a fixed resistor between the adjustment and output, the devices can be used as a precision current regulator. In order to optimize the load regulation, the current set resistor  $R_1$  (see fig. 3) should be tied as close as possible to the regulator, while the ground terminal of  $R_2$  should be near the ground of the load to provide remote ground sensing.

### EXTERNAL CAPACITORS (Fig.5)

Normally no capacitors are needed unless the devices are situated far from the input filter capacitors; in which case an input bypass is needed.

A 0.1 $\mu$ F disc or 1 $\mu$ F tantalum input bypass capacitor ( $C_1$ ) is recommended to reduce the sensitivity to input line impedance.

The adjustment terminal may be bypassed to ground to improve ripple rejection. This capacitor ( $C_{adj}$ ) prevents ripple from being amplified as the output voltage is increased. A 10 $\mu$ F capacitor should improve ripple rejection of about 80dB at 120Hz in a 10V application.

Although the LM217M/LM317M devices are stable with no output capacitance like any feedback circuit, certain values of external capacitance can cause excessive ringing. An output capacitance ( $C_O$ ) in the form of a 1 $\mu$ F tantalum or 25 $\mu$ F aluminium electrolytic capacitor on the output swamps this effect and insures stability.

### PROTECTION DIODES (Fig.5)

When external capacitors are used with any IC regulator it is sometimes necessary to add protection diodes to prevent the capacitors from discharging through low current points into the regulator.

Figure 5 shows the LM217M/LM317M with the recommended protection diodes for output voltages in excess of 25V or high capacitance values ( $C_3 > 25\mu$ F,  $C_2 > 10\mu$ F). Diode D1 prevents  $C_3$  from discharging through the IC during an input short-circuit. The combination of diodes D1 and D2 prevents  $C_2$  from discharging through the regulator during an input or output short-circuit.

### START-UP BLOCK

It's not guaranteed the Re-Boot of the device when the junction temperature is over 85°C.



Figure 5 : Voltage Regulator with Protection Diodes

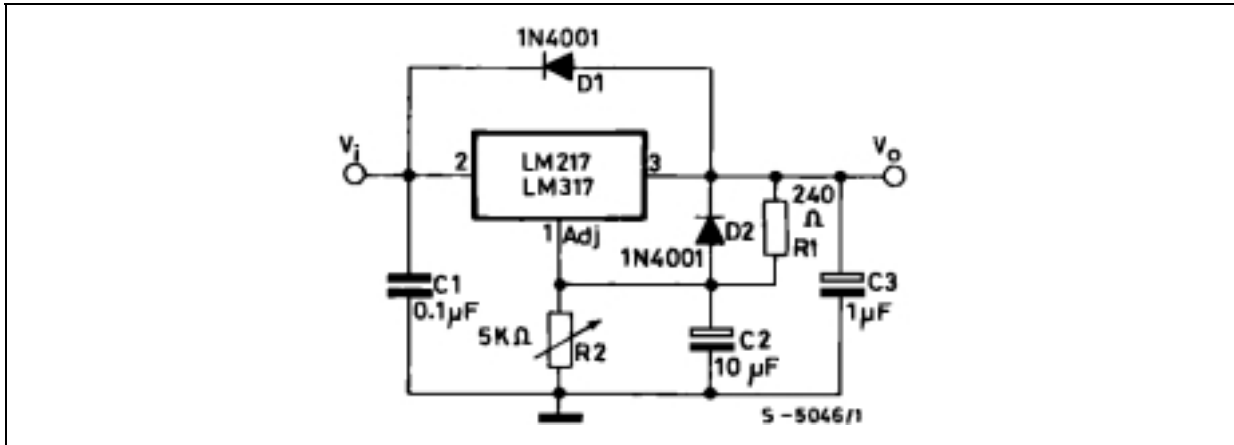

Figure 6 : Slow Turn-on 15V Regulator

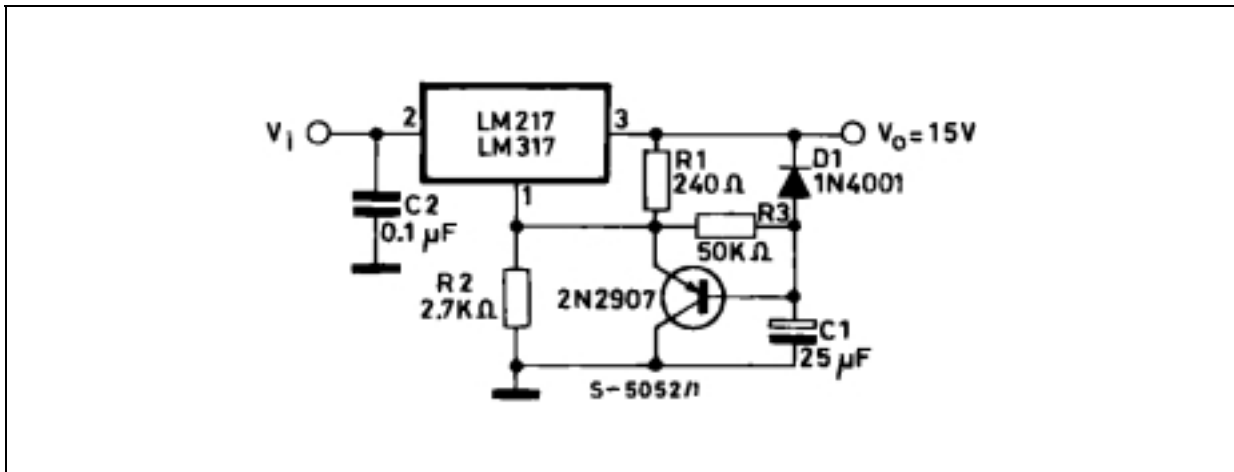

Figure 7 : Current Regulator

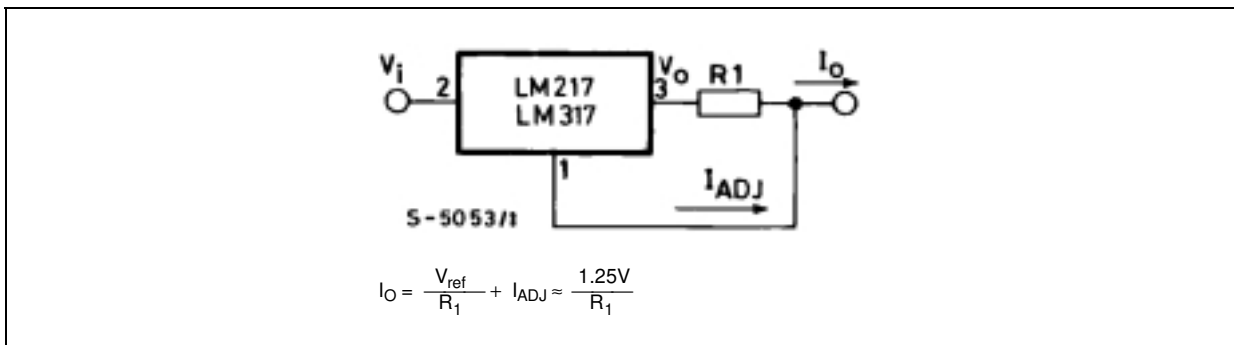

Figure 8 : 5V Electronic Shut-down Regulator

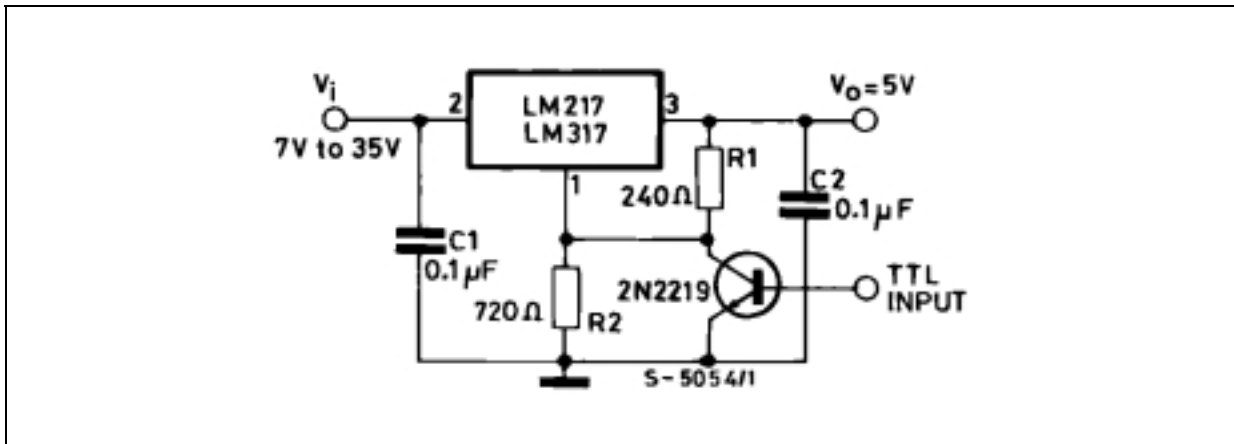
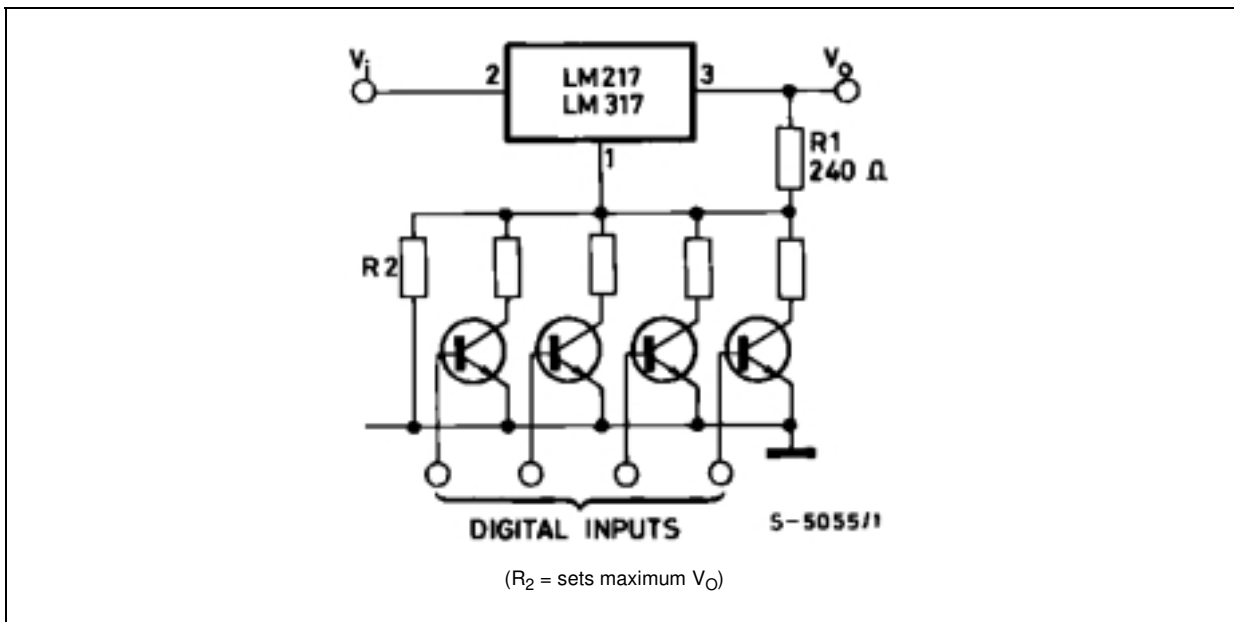

Figure 9 : Digitally Selected Outputs





**TO-220 MECHANICAL DATA**

DIM.	mm.			inch		
	MIN.	TYP.	MAX.	MIN.	TYP.	MAX.
A	4.40		4.60	0.173		0.181
C	1.23		1.32	0.048		0.051
D	2.40		2.72	0.094		0.107
D1		1.27			0.050	
E	0.49		0.70	0.019		0.027
F	0.61		0.88	0.024		0.034
F1	1.14		1.70	0.044		0.067
F2	1.14		1.70	0.044		0.067
G	4.95		5.15	0.194		0.203
G1	2.4		2.7	0.094		0.106
H2	10.0		10.40	0.393		0.409
L2		16.4			0.645	
L4	13.0		14.0	0.511		0.551
L5	2.65		2.95	0.104		0.116
L6	15.25		15.75	0.600		0.620
L7	6.2		6.6	0.244		0.260
L9	3.5		3.93	0.137		0.154
DIA.	3.75		3.85	0.147		0.151

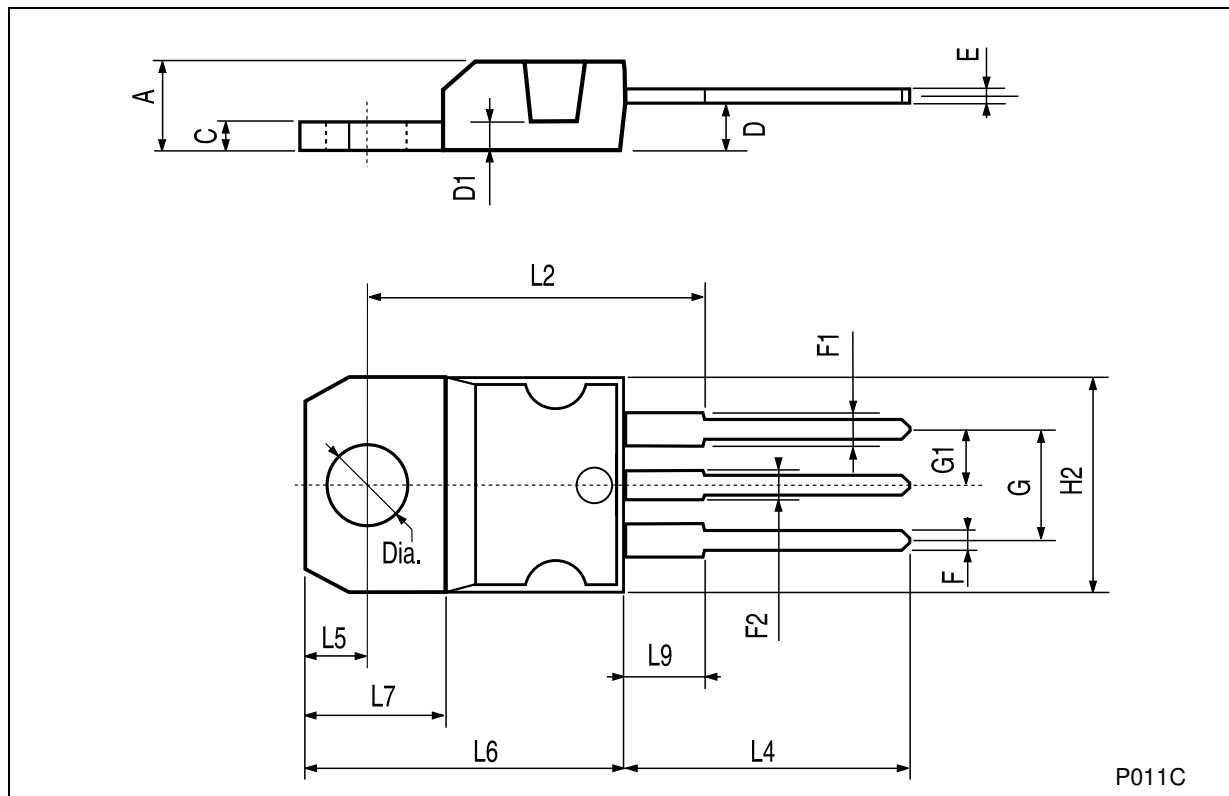

P011C

## DPAK MECHANICAL DATA

DIM.	mm.			inch		
	MIN.	TYP	MAX.	MIN.	TYP.	MAX.
A	2.2		2.4	0.086		0.094
A1	0.9		1.1	0.035		0.043
A2	0.03		0.23	0.001		0.009
B	0.64		0.9	0.025		0.035
B2	5.2		5.4	0.204		0.212
C	0.45		0.6	0.017		0.023
C2	0.48		0.6	0.019		0.023
D	6		6.2	0.236		0.244
D1		5.1			0.200	
E	6.4		6.6	0.252		0.260
E1		4.7			0.185	
e		2.28			0.090	
e1	4.4		4.6	0.173		0.181
H	9.35		10.1	0.368		0.397
L		1			0.039	
(L1)		2.8			0.110	
L2		0.8			0.031	
L4	0.6		1	0.023		0.039

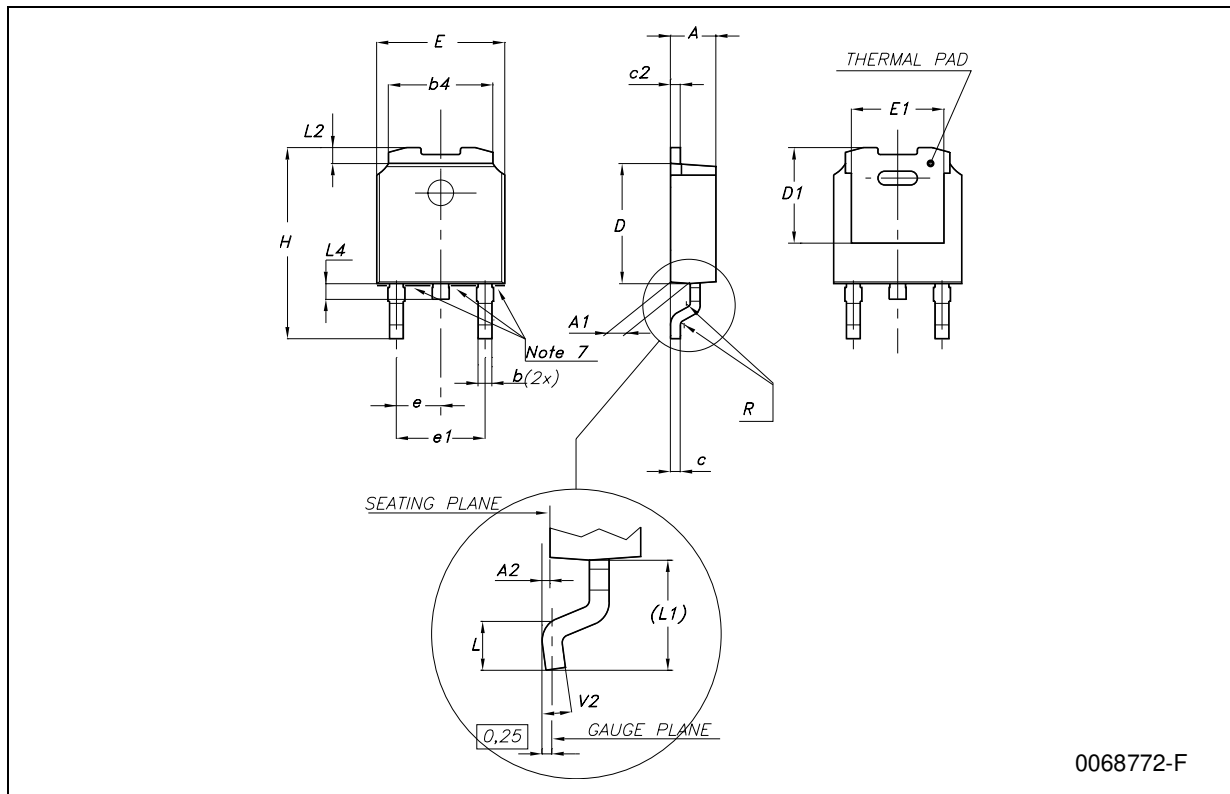

**Tape & Reel DPAK-PPAK MECHANICAL DATA**

DIM.	mm.			inch		
	MIN.	TYP	MAX.	MIN.	TYP.	MAX.
A			330			12.992
C	12.8	13.0	13.2	0.504	0.512	0.519
D	20.2			0.795		
N	60			2.362		
T			22.4			0.882
Ao	6.80	6.90	7.00	0.268	0.272	0.276
Bo	10.40	10.50	10.60	0.409	0.413	0.417
Ko	2.55	2.65	2.75	0.100	0.104	0.105
Po	3.9	4.0	4.1	0.153	0.157	0.161
P	7.9	8.0	8.1	0.311	0.315	0.319

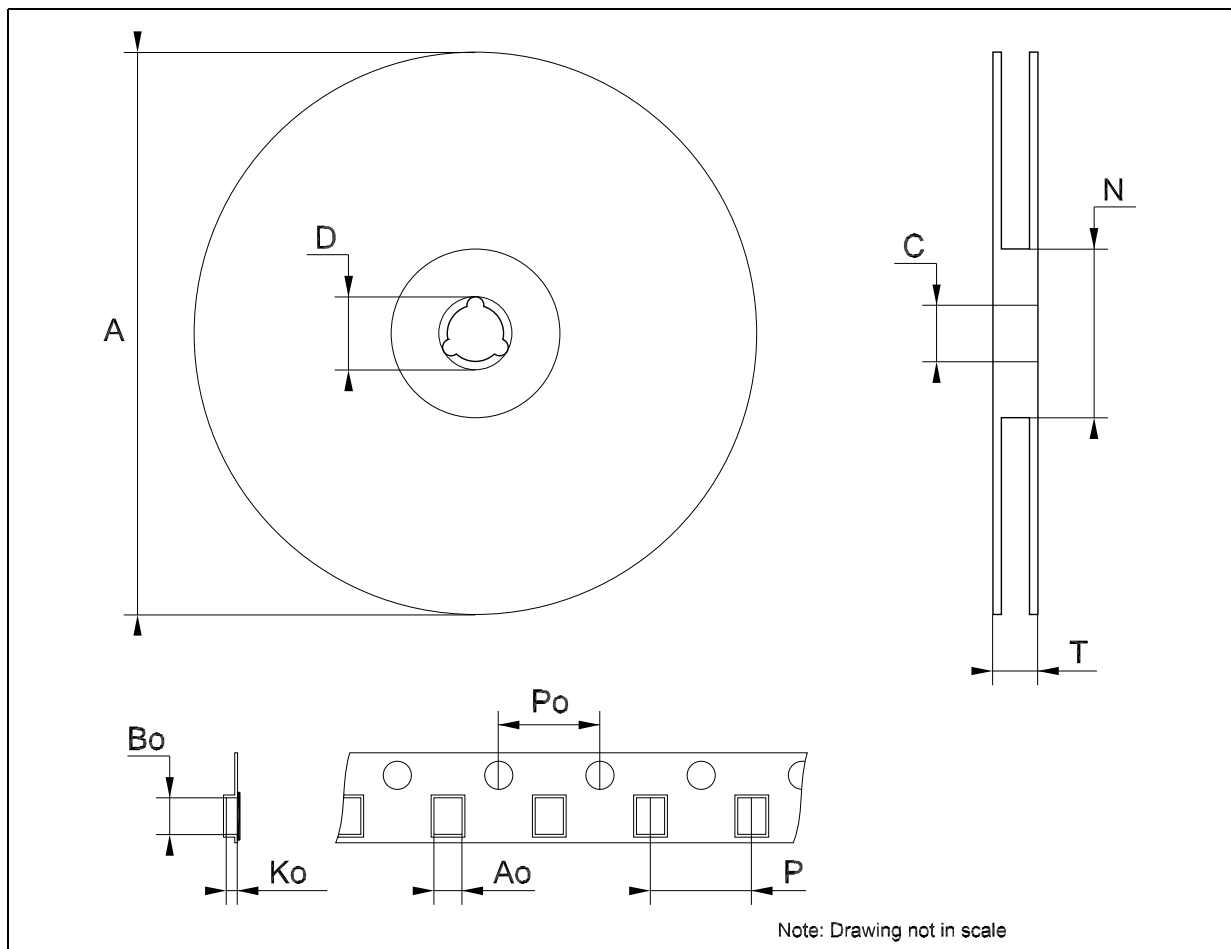

Information furnished is believed to be accurate and reliable. However, STMicroelectronics assumes no responsibility for the consequences of use of such information nor for any infringement of patents or other rights of third parties which may result from its use. No license is granted by implication or otherwise under any patent or patent rights of STMicroelectronics. Specifications mentioned in this publication are subject to change without notice. This publication supersedes and replaces all information previously supplied. STMicroelectronics products are not authorized for use as critical components in life support devices or systems without express written approval of STMicroelectronics.

The ST logo is a registered trademark of STMicroelectronics  
All other names are the property of their respective owners

© 2004 STMicroelectronics - All Rights Reserved  
STMicroelectronics GROUP OF COMPANIES

Australia - Belgium - Brazil - Canada - China - Czech Republic - Finland - France - Germany - Hong Kong - India - Israel - Italy - Japan -  
Malaysia - Malta - Morocco - Singapore - Spain - Sweden - Switzerland - United Kingdom - United States.

<http://www.st.com>