



Chipsmall Limited consists of a professional team with an average of over 10 year of expertise in the distribution of electronic components. Based in Hongkong, we have already established firm and mutual-benefit business relationships with customers from,Europe,America and south Asia,supplying obsolete and hard-to-find components to meet their specific needs.

With the principle of “Quality Parts,Customers Priority,Honest Operation,and Considerate Service”,our business mainly focus on the distribution of electronic components. Line cards we deal with include Microchip,ALPS,ROHM,Xilinx,Pulse,ON,Everlight and Freescale. Main products comprise IC,Modules,Potentiometer,IC Socket,Relay,Connector.Our parts cover such applications as commercial,industrial, and automotives areas.

We are looking forward to setting up business relationship with you and hope to provide you with the best service and solution. Let us make a better world for our industry!



## Contact us

Tel: +86-755-8981 8866 Fax: +86-755-8427 6832

Email & Skype: info@chipsmall.com Web: www.chipsmall.com

Address: A1208, Overseas Decoration Building, #122 Zhenhua RD., Futian, Shenzhen, China





# LM236-LM336

## 2.5V voltage references

### Features

- Low temperature coefficient
- Wide operating current of 400 $\mu$ A to 10mA
- 0.2 $\Omega$  dynamic impedance
- Guaranteed temperature stability
- Fast turn-on

### Description

The LM236 and LM336 are precision 2.5V regulator diodes. These voltage reference monolithic ICs operate like 2.5V Zener diodes with a low temperature coefficient and a dynamic impedance of 0.2 $\Omega$ . A third pin enables adjusting the reference voltage and the temperature coefficient.



**TO92**  
(Plastic package)

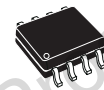

**SO8**  
(Plastic micropackage)

### Pin connections

**TO92**  
(Bottom view)

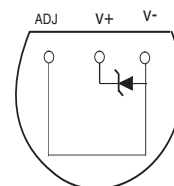

**SO8**  
(Top view)

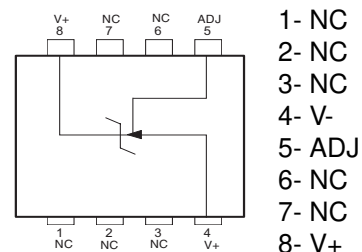

## 1 Schematic diagram

Figure 1. Schematic diagram

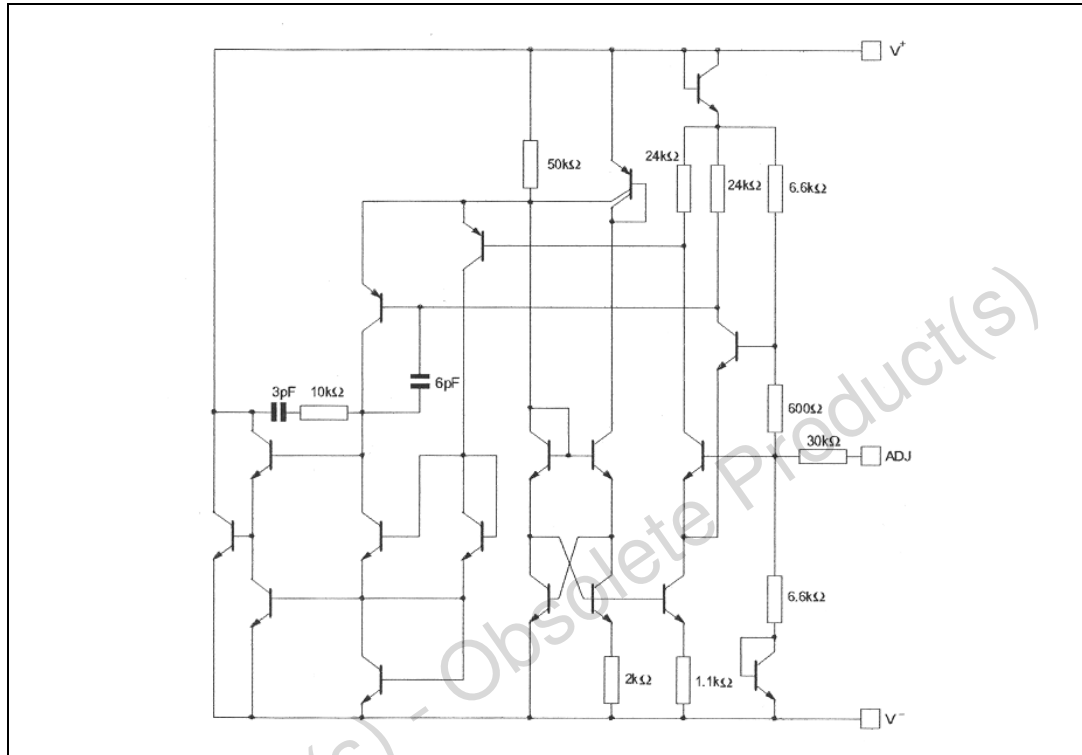

## 2 Absolute maximum ratings

Table 1. Absolute maximum ratings (AMR)

Symbol	Parameter	LM236	LM336,B	Unit
$I_R$ $I_F$	Current Reverse Forward		15 10	mA
$T_{oper}$	Operating free-air temperature range	-25 to +85	0 to +70	°C
$T_{stg}$	Storage temperature range	-65 to +150		°C

### 3 Electrical characteristics

Table 2. Electrical characteristics

Symbol	Parameter	LM236			LM336,B			Unit
		Min.	Typ.	Max.	Min.	Typ.	Max.	
$V_R$	Reference breakdown voltage $T_{amb} = +25^\circ\text{C}$ , $I_R = 1\text{mA}$ LM236, LM336 LM336B	2.44	2.49	2.54	2.39 2.44	2.49	2.59 2.54	V
$\Delta V_R$	Reverse breakdown voltage change with current $400\mu\text{A} \leq I_R \leq 10\text{mA}$ $T_{amb} = +25^\circ\text{C}$ $T_{min} \leq T_{amb} \leq T_{max}$		2.6 3	6 10		2.6 3	10 12	mV
$Z_D$	Reverse dynamic impedance ( $I_R = 1\text{mA}$ ) $T_{amb} = +25^\circ\text{C}$ $T_{min} \leq T_{amb} \leq T_{max}$		0.2 0.4	0.6 1		0.2 0.4	1 1.4	$\Omega$
$K_{VT}$	Temperature stability ( $V_R = 2.49\text{V}$ , $I_R = 1\text{mA}$ )		3.5	9		1.8	6	mV
$K_{VH}$	Long term stability ( $T_{amb} = +25^\circ\text{C} \pm 0.1^\circ\text{C}$ , $I_R = 1\text{mA}$ )		20			20		ppm

Figure 2. Reverse voltage change

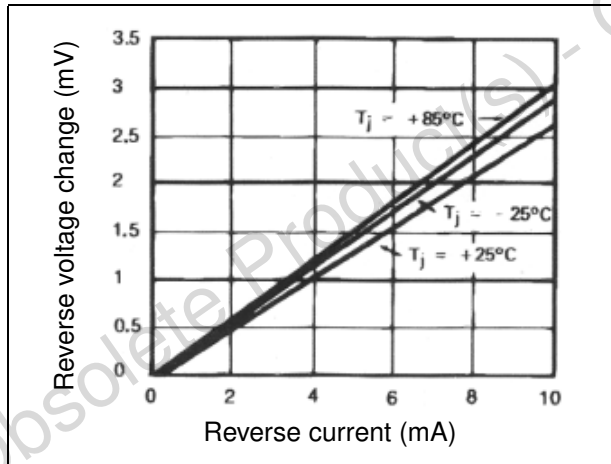

Figure 3. Zener noise voltage

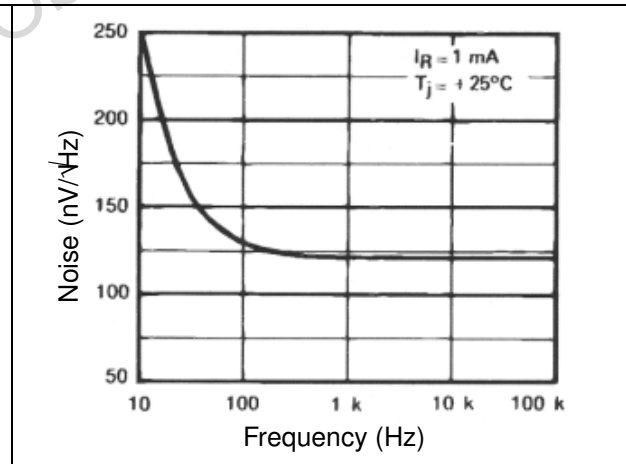

Figure 4. Dynamic impedance

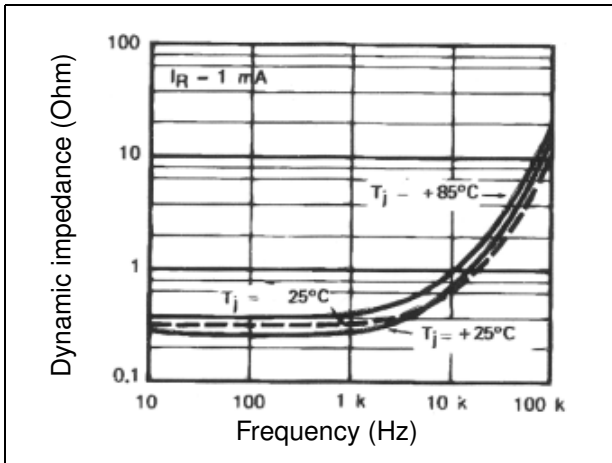

Figure 5. Response time

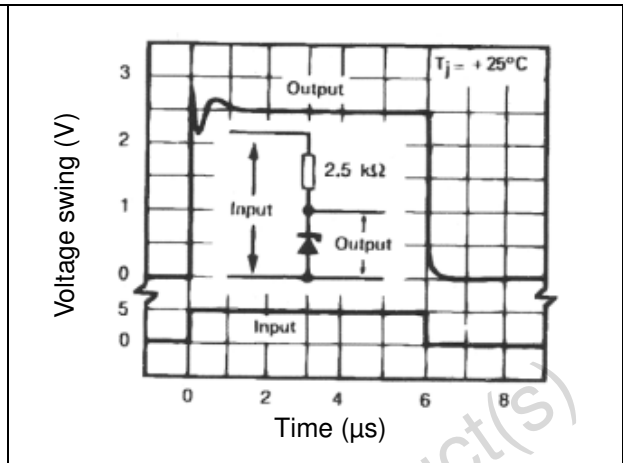

Figure 6. Reverse characteristics

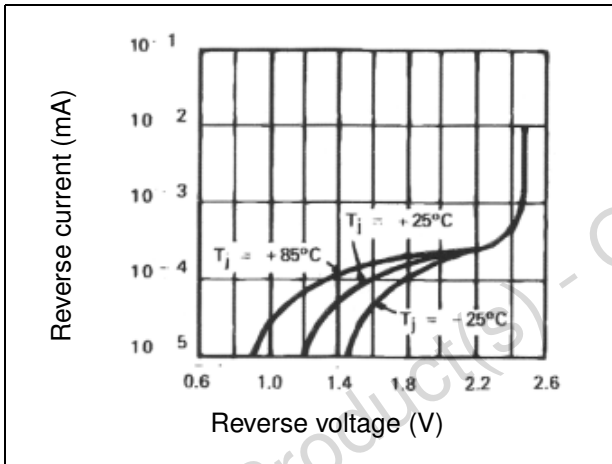

Figure 7. Forward characteristics

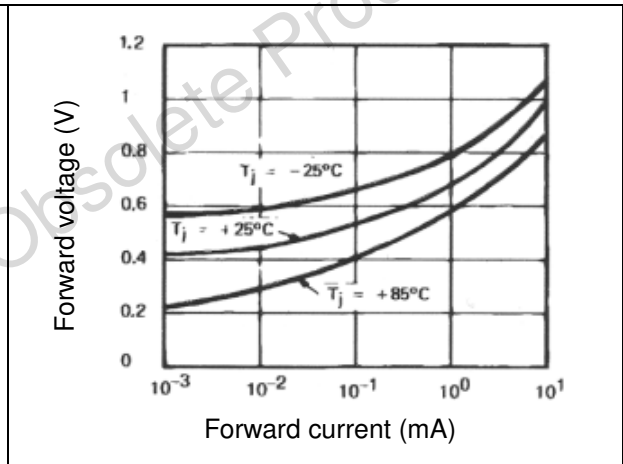
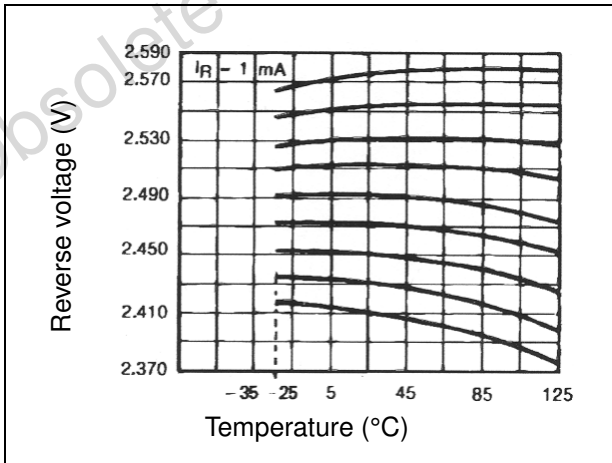

Figure 8. Temperature drift



## 4 Application information

The LM236, LM336 voltage references are easier to use than zener diodes. Their low impedance and wide current range facilitate biasing in any circuits. Besides, the breakdown voltage or the temperature coefficient can be adjusted so as to optimize the performance of the circuit.

*Figure 9* represents a LM336 with a 10kΩ potentiometer to adjust the reverse breakdown voltage which can be adjusted without altering the temperature coefficient of the circuit. The adjustment range is generally sufficient to adjust the initial tolerance of the circuit and the inaccuracy of the amplifier circuit.

To obtain a lower temperature coefficient two diodes can be connected in series as indicated in *Figure 10*.

When the circuit is adjusted to 2.49V the temperature coefficient is minimized.

For a correct temperature coefficient, the diodes should be at the same ambient temperature as the LM336. The value of R1 is not critical (2-20kΩ).

**Figure 9. LM336 with pot for adjustment of breakdown voltage**

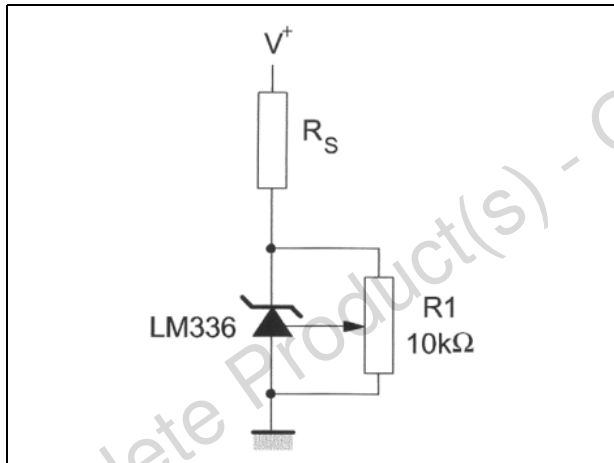

**Figure 10. Temperature coefficient adjustment**

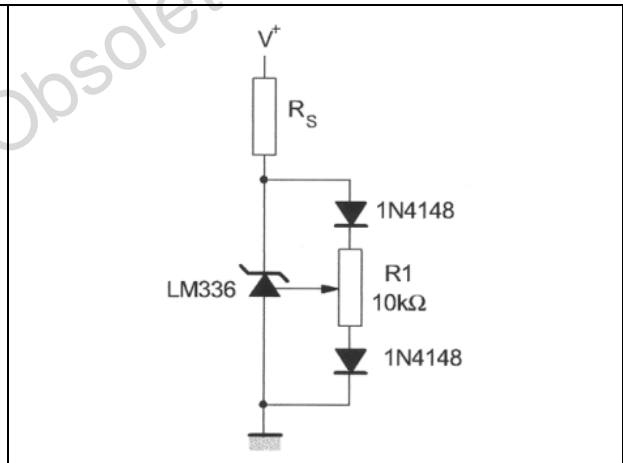

### Typical applications

Figure 11. 2.5V reference

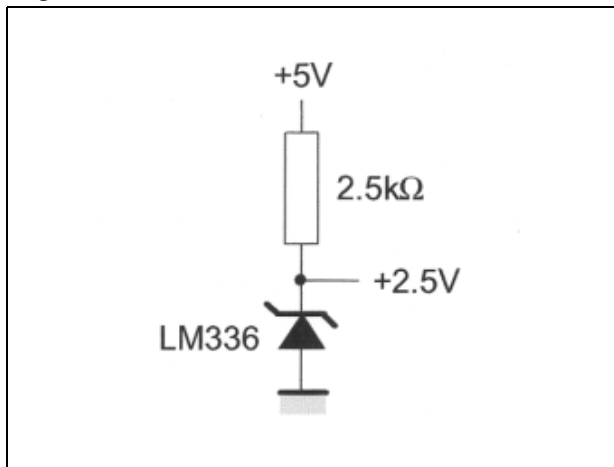

Figure 12. Wide input range reference

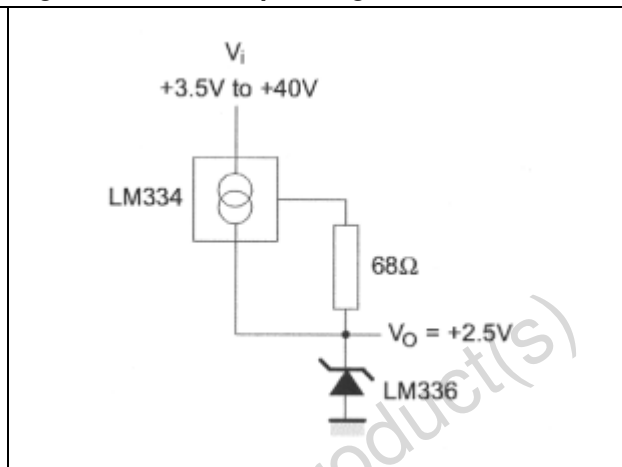

Figure 13. Precision power regulator with low temperature coefficient

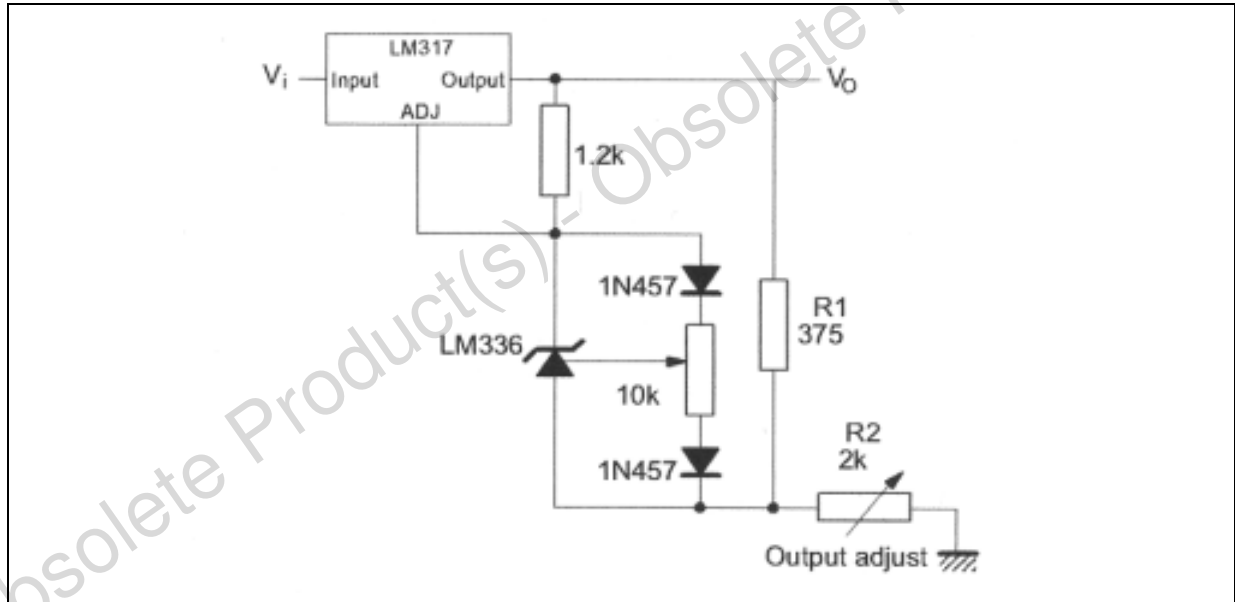

Figure 14. Adjustable shunt regulator

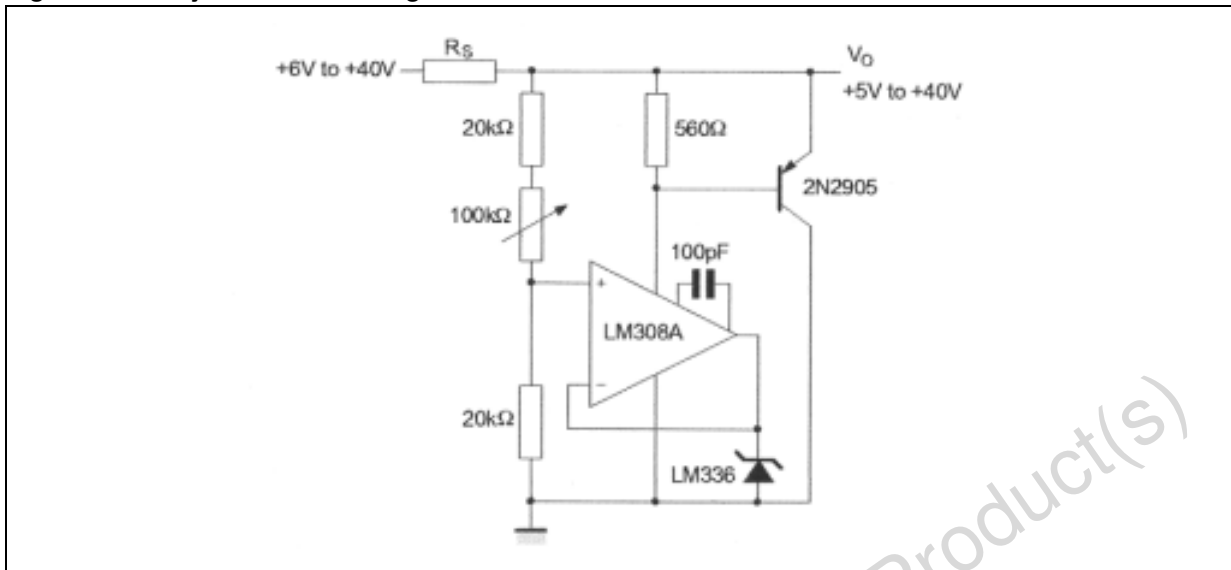

Figure 15. Linear ohmmeter

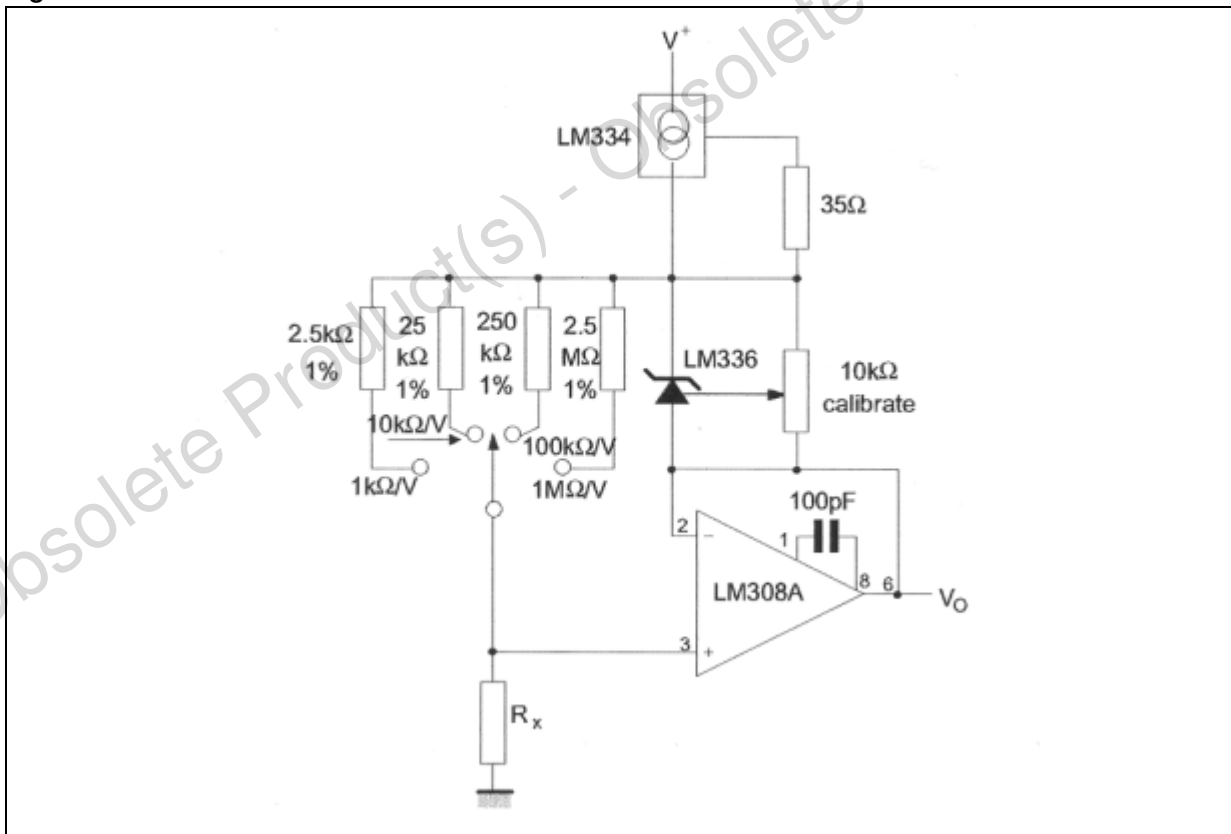



Figure 16. Bipolar output reference

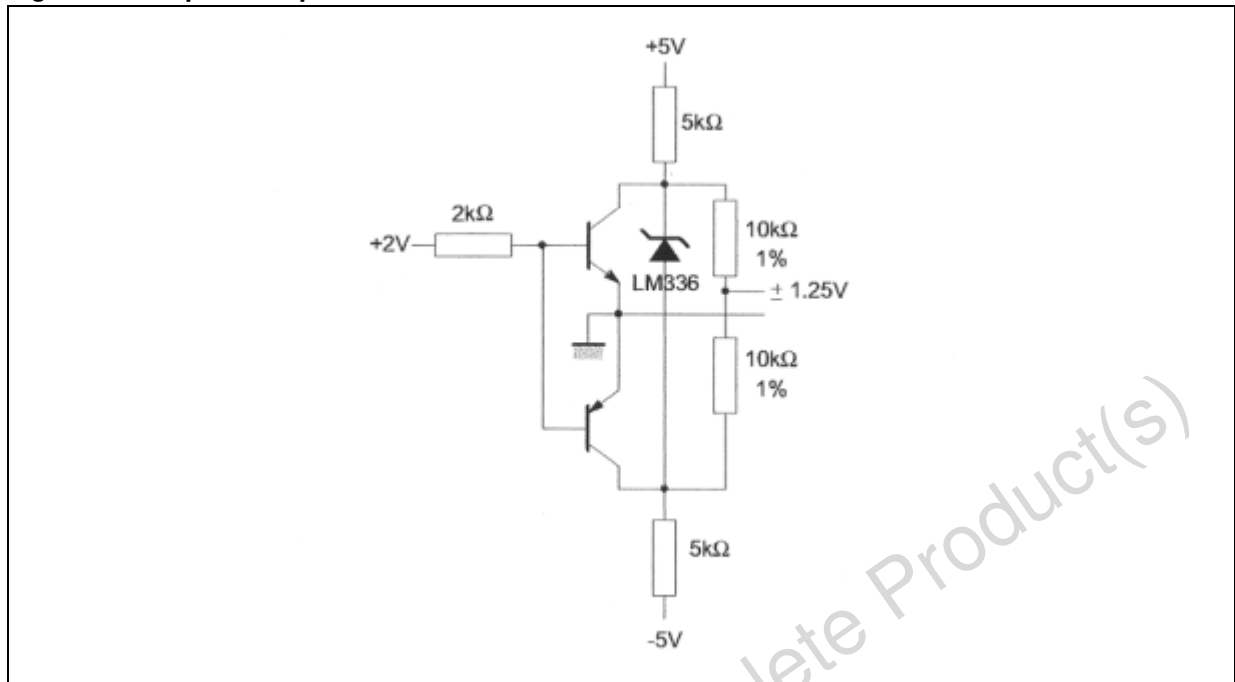

Figure 17. 5V buffered reference

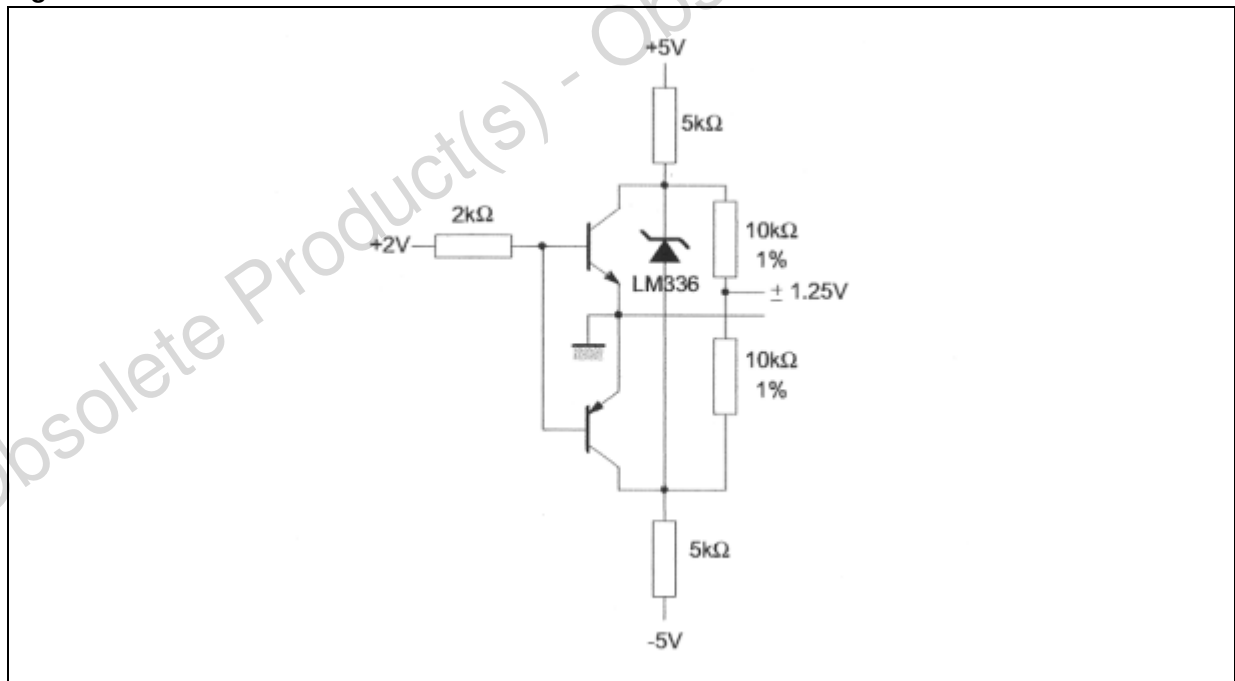
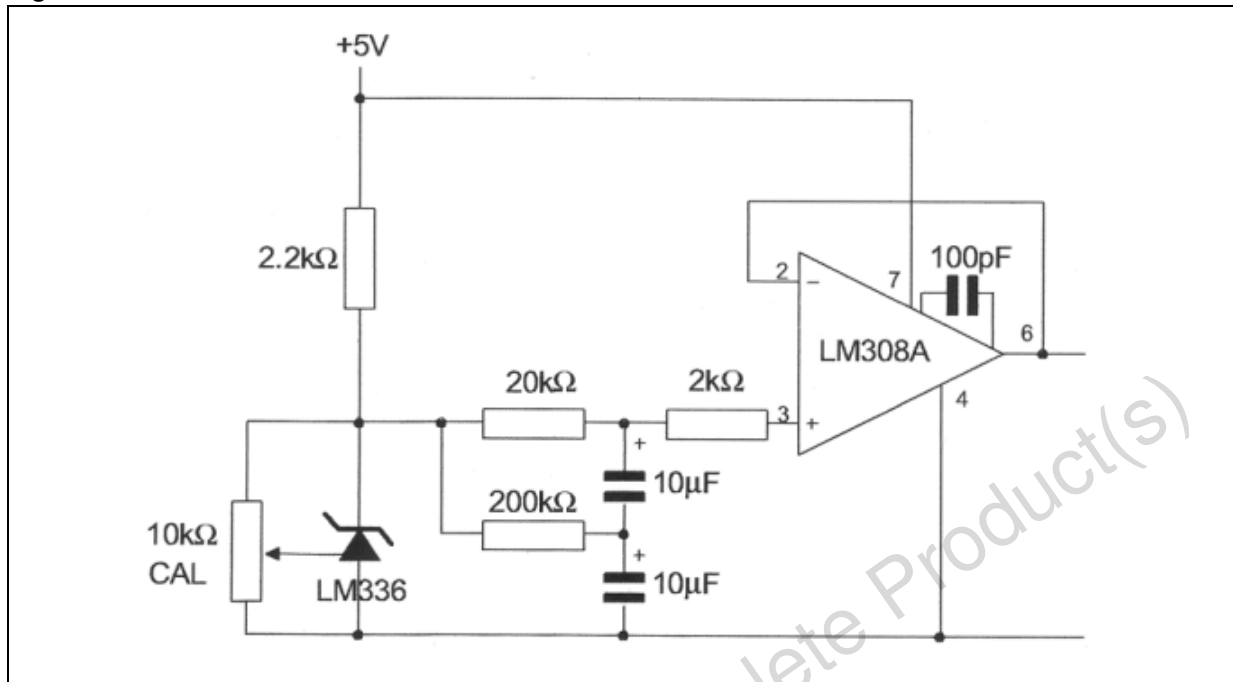

Figure 18. Low noise buffered reference



## 5 Package information

In order to meet environmental requirements, STMicroelectronics offers these devices in ECOPACK® packages. These packages have a lead-free second level interconnect. The category of second level interconnect is marked on the package and on the inner box label, in compliance with JEDEC Standard JESD97. The maximum ratings related to soldering conditions are also marked on the inner box label. ECOPACK is an STMicroelectronics trademark. ECOPACK specifications are available at: [www.st.com](http://www.st.com).

Obsolete Product(s) - Obsolete Product(s)

5.1 SO-8 package mechanical data

Ref.	Dimensions					
	Millimeters			Inches		
	Min.	Typ.	Max.	Min.	Typ.	Max.
A			1.75			0.069
A1	0.10		0.25	0.004		0.010
A2	1.25			0.049		
b	0.28		0.48	0.011		0.019
c	0.17		0.23	0.007		0.010
D	4.80	4.90	5.00	0.189	0.193	0.197
H	5.80	6.00	6.20	0.228	0.236	0.244
E1	3.80	3.90	4.00	0.150	0.154	0.157
e		1.27			0.050	
h	0.25		0.50	0.010		0.020
L	0.40		1.27	0.016		0.050
k	1°		8°	1°		8°
ccc			0.10			0.004

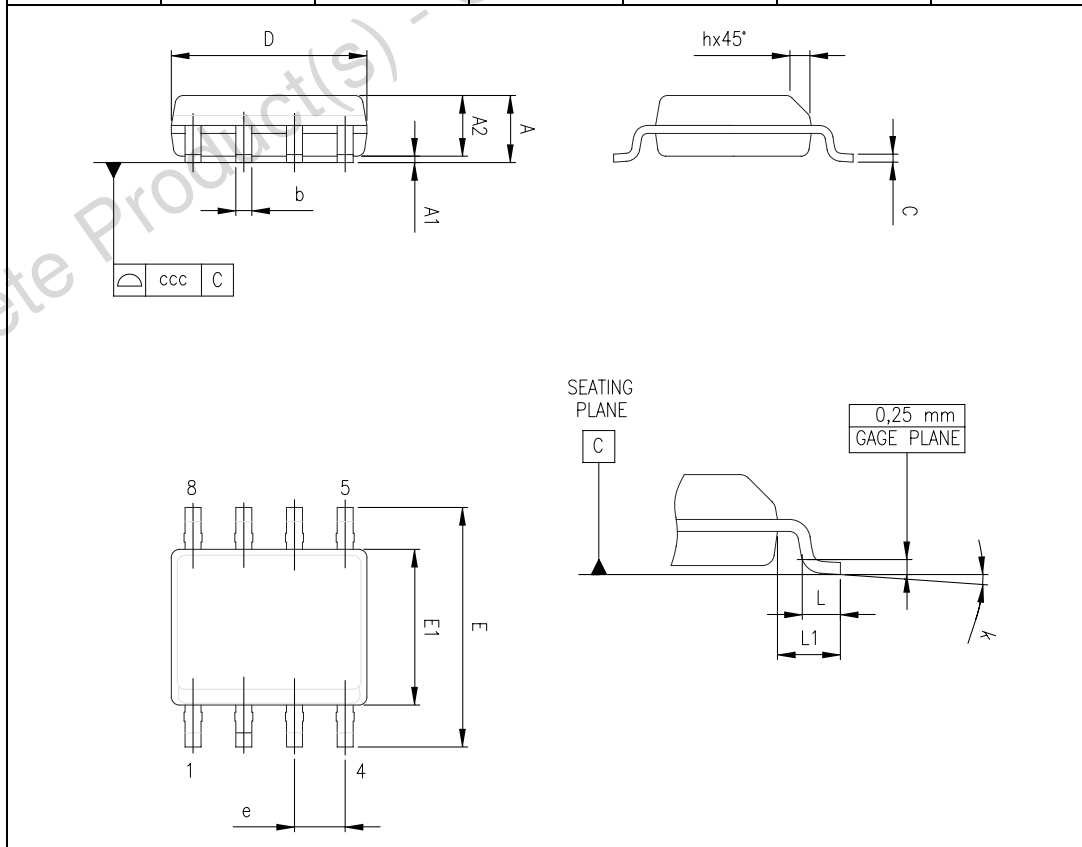

## 5.2 TO-92 ammpack and tape & reel package mechanical data

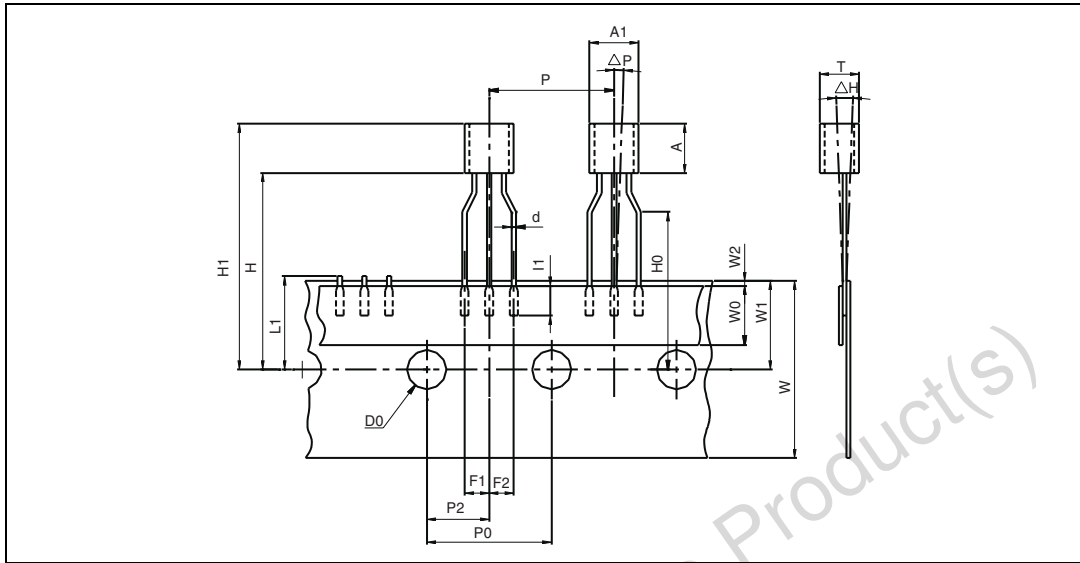

Dim.	Millimeters			Inches		
	Min.	Typ.	Max.	Min.	Typ.	Max.
AL			5.0			0.197
A			5.0			0.197
T			4.0			0.157
d		0.45			0.018	
l1	2.5			0.098		
P	11.7	12.7	13.7	0.461	0.500	0.539
P0	12.4	12.7	13	0.488	0.500	0.512
P2	5.95	6.35	6.75	0.234	0.250	0.266
F1/F2	2.4	2.5	2.8	0.094	0.098	0.110
Δh	-1	0	1	-0.039	0	0.039
ΔP	-1	0	1	-0.039	0	0.039
W	17.5	18.0	19.0	0.689	0.709	0.748
W0	5.7	6	6.3	0.224	0.236	0.248
W1	8.5	9	9.75	0.335	0.354	0.384
W2			0.5			0.020
H			20			0.787
H0	15.5	16	16.5	0.610	0.630	0.650
H1			25			0.984
DO	3.8	4.0	4.2	0.150	0.157	0.165
L1			11			0.433

### 5.3 TO-92 bulk package mechanical data

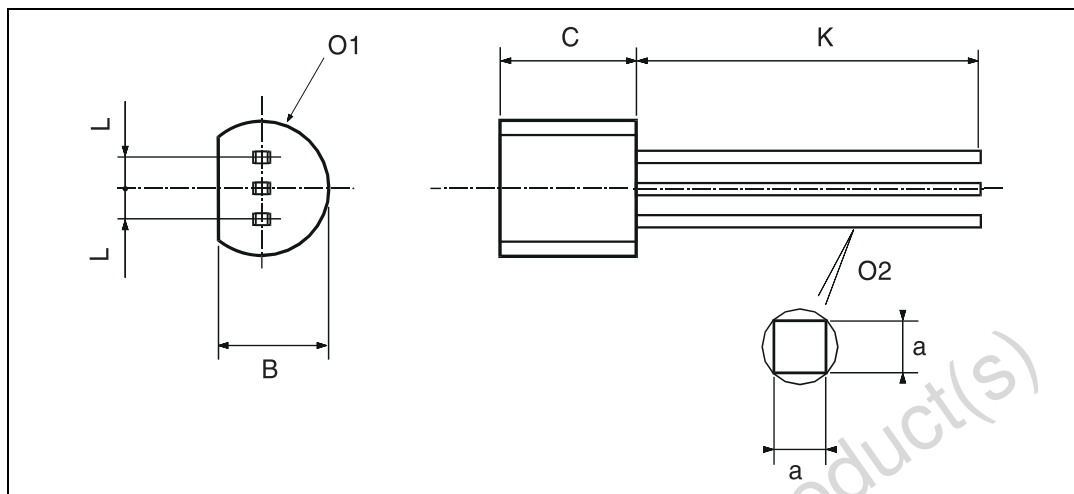

Dim.	Millimeters			Inches		
	Min.	Typ.	Max.	Min.	Typ.	Max.
L		1.27		0.05		
B	3.2	3.7	4.2	0.126	0.1457	0.1654
O1	4.45	5.00	5.2	0.1752	0.1969	0.2047
C	4.58	5.03	5.33	0.1803	0.198	0.2098
K	12.7			0.5		
O2	0.407	0.5	0.508	0.016	0.0197	0.02
a	0.35			0.0138		

## 6 Ordering information

Table 3. Order codes

Part number	Temperature range	Package	Packing	Marking
LM236D/DT	-25°C to +85°C	SO-8	Tube or Tape & reel	LM236
LM236Z/ZT/AP	-25°C to +85°C	TO-92	Bulk or Tape & reel or Ammopack	LM236
LM336D/DT	-25°C to +85°C	SO-8	Tube or Tape & reel	LM336
LM336Z/ZT/AP	-25°C to +85°C	TO-92	Bulk or Tape & reel or Ammopack	LM336
LM336BD/BDT	0°C to 70°C	SO-8	Tube or Tape & reel	LM336B
LM336BZ/BZT/BAP	0°C to 70°C	TO-92	Bulk or Tape & reel or Ammopack	LM336B

## 7 Revision history

Date	Revision	Changes
2-May-1997	1	Initial release.
24-May-2003	2	Caption of pinout diagram for TO-92 package changed to indicate top view.
29-May-2007	3	Corrected caption of pinout diagram for TO-92 package on cover page (previous version is wrong, should be bottom view). Updated <a href="#">Section 5: Package information</a> and <a href="#">Table 3: Order codes</a> .

**Please Read Carefully:**

Information in this document is provided solely in connection with ST products. STMicroelectronics NV and its subsidiaries ("ST") reserve the right to make changes, corrections, modifications or improvements, to this document, and the products and services described herein at any time, without notice.

All ST products are sold pursuant to ST's terms and conditions of sale.

Purchasers are solely responsible for the choice, selection and use of the ST products and services described herein, and ST assumes no liability whatsoever relating to the choice, selection or use of the ST products and services described herein.

No license, express or implied, by estoppel or otherwise, to any intellectual property rights is granted under this document. If any part of this document refers to any third party products or services it shall not be deemed a license grant by ST for the use of such third party products or services, or any intellectual property contained therein or considered as a warranty covering the use in any manner whatsoever of such third party products or services or any intellectual property contained therein.

**UNLESS OTHERWISE SET FORTH IN ST'S TERMS AND CONDITIONS OF SALE ST DISCLAIMS ANY EXPRESS OR IMPLIED WARRANTY WITH RESPECT TO THE USE AND/OR SALE OF ST PRODUCTS INCLUDING WITHOUT LIMITATION IMPLIED WARRANTIES OF MERCHANTABILITY, FITNESS FOR A PARTICULAR PURPOSE (AND THEIR EQUIVALENTS UNDER THE LAWS OF ANY JURISDICTION), OR INFRINGEMENT OF ANY PATENT, COPYRIGHT OR OTHER INTELLECTUAL PROPERTY RIGHT.**

**UNLESS EXPRESSLY APPROVED IN WRITING BY AN AUTHORIZED ST REPRESENTATIVE, ST PRODUCTS ARE NOT RECOMMENDED, AUTHORIZED OR WARRANTED FOR USE IN MILITARY, AIR CRAFT, SPACE, LIFE SAVING, OR LIFE SUSTAINING APPLICATIONS, NOR IN PRODUCTS OR SYSTEMS WHERE FAILURE OR MALFUNCTION MAY RESULT IN PERSONAL INJURY, DEATH, OR SEVERE PROPERTY OR ENVIRONMENTAL DAMAGE. ST PRODUCTS WHICH ARE NOT SPECIFIED AS "AUTOMOTIVE GRADE" MAY ONLY BE USED IN AUTOMOTIVE APPLICATIONS AT USER'S OWN RISK.**

Resale of ST products with provisions different from the statements and/or technical features set forth in this document shall immediately void any warranty granted by ST for the ST product or service described herein and shall not create or extend in any manner whatsoever, any liability of ST.

ST and the ST logo are trademarks or registered trademarks of ST in various countries.

Information in this document supersedes and replaces all information previously supplied.

The ST logo is a registered trademark of STMicroelectronics. All other names are the property of their respective owners.

© 2007 STMicroelectronics - All rights reserved

STMicroelectronics group of companies

Australia - Belgium - Brazil - Canada - China - Czech Republic - Finland - France - Germany - Hong Kong - India - Israel - Italy - Japan - Malaysia - Malta - Morocco - Singapore - Spain - Sweden - Switzerland - United Kingdom - United States of America

[www.st.com](http://www.st.com)

