



Chipsmall Limited consists of a professional team with an average of over 10 year of expertise in the distribution of electronic components. Based in Hongkong, we have already established firm and mutual-benefit business relationships with customers from,Europe,America and south Asia,supplying obsolete and hard-to-find components to meet their specific needs.

With the principle of “Quality Parts,Customers Priority,Honest Operation,and Considerate Service”,our business mainly focus on the distribution of electronic components. Line cards we deal with include Microchip,ALPS,ROHM,Xilinx,Pulse,ON,Everlight and Freescale. Main products comprise IC,Modules,Potentiometer,IC Socket,Relay,Connector.Our parts cover such applications as commercial,industrial, and automotives areas.

We are looking forward to setting up business relationship with you and hope to provide you with the best service and solution. Let us make a better world for our industry!



Contact us

Tel: +86-755-8981 8866 Fax: +86-755-8427 6832

Email & Skype: info@chipsmall.com Web: www.chipsmall.com

Address: A1208, Overseas Decoration Building, #122 Zhenhua RD., Futian, Shenzhen, China





LM193W, LM293W, LM393W

Low power dual voltage comparators

Features

- Wide single supply voltage range or dual supplies: +2 V to +36 V or ± 1 V to ± 18 V
- Very low supply current (0.4 mA) independent of supply voltage (1 mW/comparator at +5 V)
- Low input bias current: 25 nA typ
- Low input offset current: ± 5 nA typ
- Low input offset voltage: ± 1 mV typ
- Input common-mode voltage range includes ground
- Low output saturation voltage: 250 mV typ. ($I_o = 4$ mA)
- Differential input voltage range equal to the supply voltage
- TTL, DTL, ECL, MOS, CMOS compatible outputs
- ESD internal protection: 2 kV

Description

These devices consist of two independent low voltage comparators designed specifically to operate from a single supply over a wide range of voltages. Operation from split power supplies is also possible.

These comparators also have a unique characteristic in that the input common-mode voltage range includes ground even though operated from a single power supply voltage.

All the pins are protected against electrostatic discharge up to 2 kV. As a consequence, the input voltages must not exceed the magnitude of V_{CC^+} or V_{CC^-} .



DIP8
(Plastic package)



SO8
(Plastic micropackage)



TSSOP8
(Thin shrink small outline package)

Pin connections (Top view)

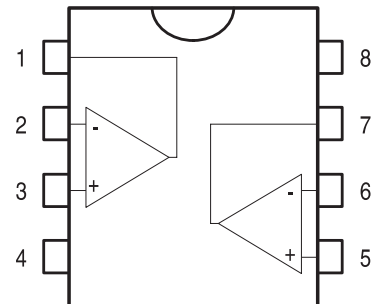

- 1 - Output 1
- 2 - Inverting input 1
- 3 - Non-inverting input 1
- 4 - V_{CC^-}
- 5 - Non-inverting input 2
- 6 - Inverting input 2
- 7 - Output 2
- 8 - V_{CC^+}

1 Schematic diagram

Figure 1. Circuit schematic (1/2 LM193W)

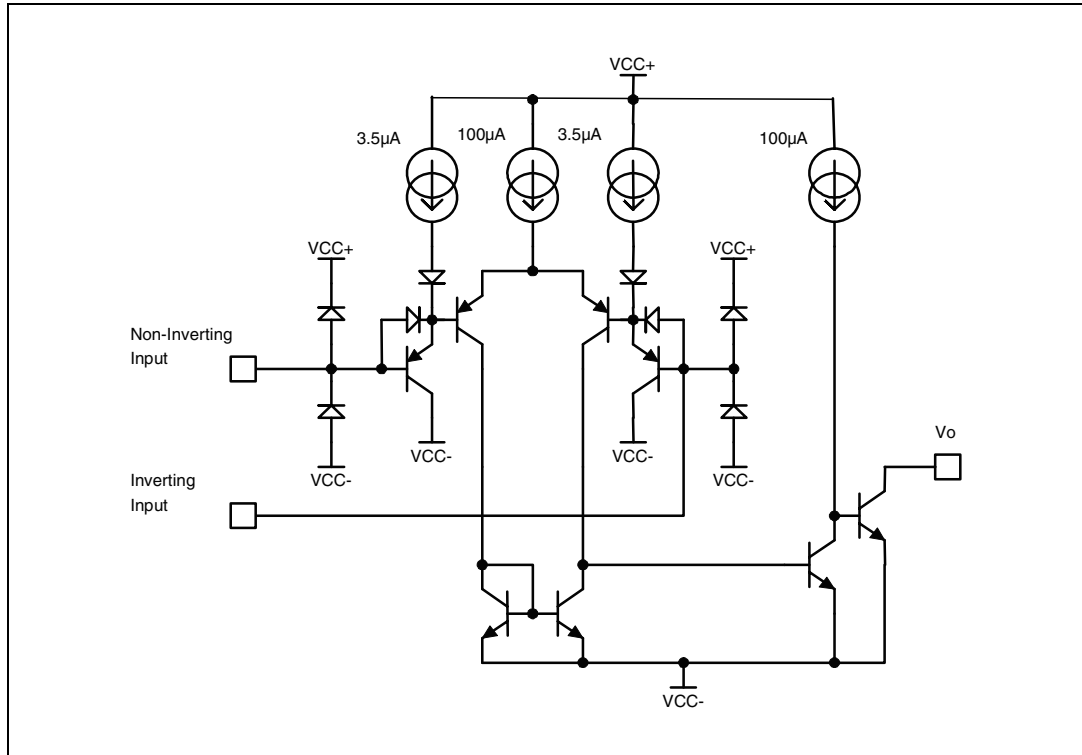

2 Absolute maximum ratings and operating conditions

Table 1. Absolute maximum ratings

Symbol	Parameter	Value	Unit
V_{CC}	Supply voltage	± 18 or 36	V
V_{id}	Differential input voltage	$V_{CC}^- - 0.3$ to $V_{CC}^+ + 0.3$	V
V_{in}	Input voltage		
	Output short-circuit to ground ⁽¹⁾	Infinite	
R_{thja}	Thermal resistance junction to ambient ⁽²⁾		°C/W
	SO-8	125	
	TSSOP8 DIP8	120 85	
R_{thjc}	Thermal resistance junction to case ⁽²⁾		°C/W
	SO-8	40	
	TSSOP8 DIP8	37 41	
T_j	Junction temperature	150	°C
T_{stg}	Storage temperature range	-65 to +150	°C
ESD	HBM: human body model ⁽³⁾	2000	V
	MM: machine model ⁽⁴⁾	200	
	CDM: charged device model ⁽⁵⁾	1500	

- Short-circuits from the output to V_{CC}^+ can cause excessive heating and eventual destruction. The maximum output current is approximately 20mA independent of the magnitude of V_{CC}^+ .
- Short-circuits can cause excessive heating and destructive dissipation. Values are typical.
- Human body model: a 100 pF capacitor is charged to the specified voltage, then discharged through a 1.5k Ω resistor between two pins of the device. This is done for all couples of connected pin combinations while the other pins are floating.
- Machine model: a 200 pF capacitor is charged to the specified voltage, then discharged directly between two pins of the device with no external series resistor (internal resistor < 5 Ω). This is done for all couples of connected pin combinations while the other pins are floating.
- Charged device model: all pins and the package are charged together to the specified voltage and then discharged directly to the ground through only one pin. This is done for all pins.

Table 2. Operating conditions

Symbol	Parameter	Value	Unit
V_{icm}	Common mode input voltage range	0 to $V_{CC}^+ - 1.5$	V
T_{oper}	Operating free-air temperature range		°C
	LM193W	-55 to +125	
	LM293W LM393W	-40 to +105 0 to +70	

3 Electrical characteristics

Table 3. $V_{CC}^+ = +5V$, $V_{CC}^- = 0V$, $T_{amb} = +25^\circ C$ (unless otherwise specified)

Symbol	Parameter	Min	Typ.	Max.	Unit
V_{io}	Input offset voltage ⁽¹⁾ $T_{amb} = +25^\circ C$ $T_{min} \leq T_{amb} \leq T_{max}$		1	5 9	mV
I_{ib}	Input bias current ⁽²⁾ $T_{amb} = +25^\circ C$ $T_{min} \leq T_{amb} \leq T_{max}$		25	250 400	nA
I_{io}	Input offset current $T_{amb} = +25^\circ C$ $T_{min} \leq T_{amb} \leq T_{max}$		5	50 150	nA
A_{vd}	Large signal voltage gain $V_{CC} = 15V$, $R_L = 15k\Omega$, $V_o = 1V$ to $11V$	50	200		V/mV
I_{CC}	Supply current (all comparators) $V_{CC} = 5V$, no load $V_{CC} = 30V$, no load		0.4 1	1 2.5	mA
V_{icm}	Input common mode voltage range ⁽³⁾ $T_{amb} = +25^\circ C$ $T_{min} \leq T_{amb} \leq T_{max}$	0 0		$V_{CC}^+ - 1.5$ $V_{CC}^+ - 2$	V
V_{id}	Differential input voltage ⁽⁴⁾			V_{CC}^+	V
I_{sink}	Output sink current $V_{id} = 1V$, $V_o = 1.5V$	6	16		mA
V_{OL}	Low level output voltage, $V_{id} = -1V$, $I_{sink} = 4mA$ $T_{amb} = +25^\circ C$ $T_{min} \leq T_{amb} \leq T_{max}$		250	400 700	mV
I_{OH}	High level output current, $V_{id} = 1V$, $V_{CC} = V_o = 30V$ $T_{amb} = +25^\circ C$ $T_{min} \leq T_{amb} \leq T_{max}$		0.1	1	nA μA
t_{re}	Response time ⁽⁵⁾ $R_L = 5.1k\Omega$ to V_{CC}^+		1.3		μs
t_{rel}	Large signal response time $V_i = TTL$, $V_{(ref)} = +1.4V$, $R_L = 5.1k\Omega$ to V_{CC}^+		300		ns

1. At output switch point, $V_o \approx 1.4V$, $R_s = 0$ with V_{CC}^+ from 5 V to 30 V, and over the full common-mode range (0 V to $V_{CC}^+ - 1.5V$).
2. The direction of the input current is out of the IC due to the PNP input stage. This current is essentially constant, independent of the state of the output, so there is no loading charge on the reference of input lines.
3. The input common-mode voltage of either input signal voltage should not be allowed to go negative by more than 0.3 V. The upper end of the common-mode voltage range is $V_{CC}^+ - 1.5V$, but either or both inputs can go to +30 V without damage.
4. Positive excursions of input voltage may exceed the power supply level. As long as the other voltage remains within the common-mode range, the comparator will provide a proper output state. The low input voltage state must not be less than -0.3 V (or 0.3 V below the negative power supply, if used).
5. The response time specified is for a 100 mV input step with 5 mV overdrive. For larger overdrive signals 300 ns can be obtained.

Figure 2. Supply current versus supply voltage

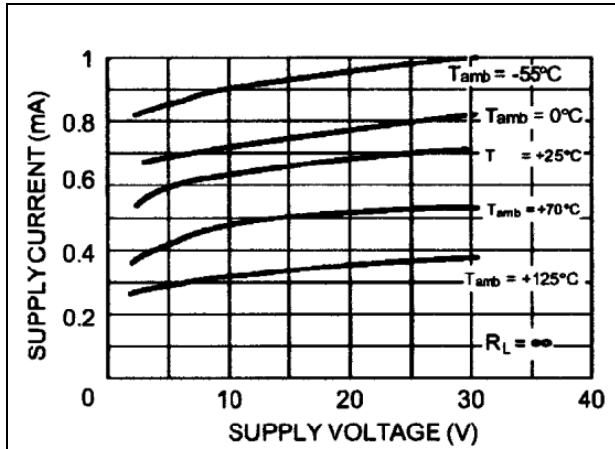

Figure 3. Input current versus supply voltage

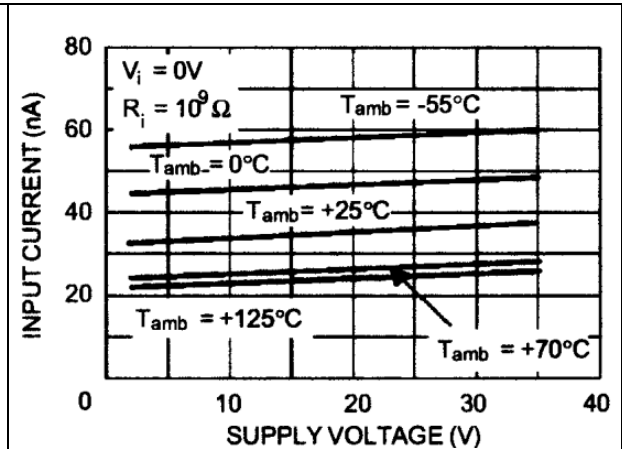

Figure 4. Output saturation voltage versus output current

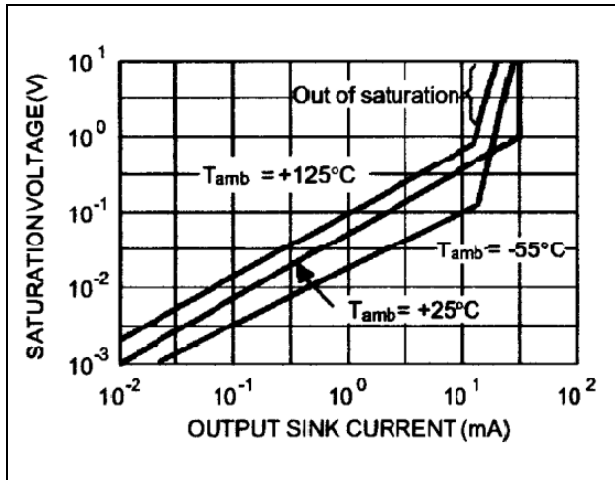

Figure 5. Response time for various input overdrives - negative transition

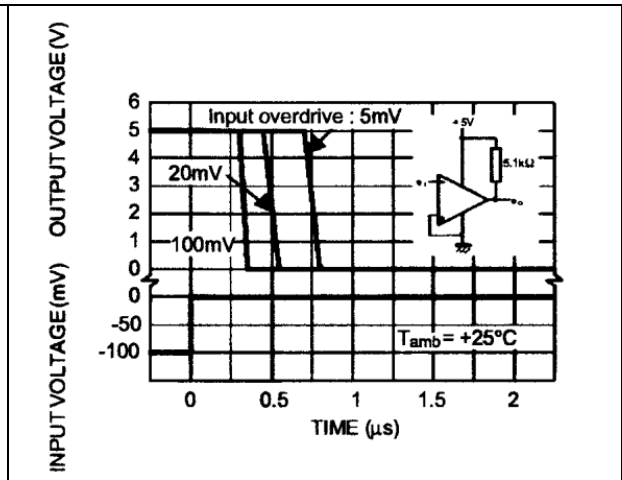
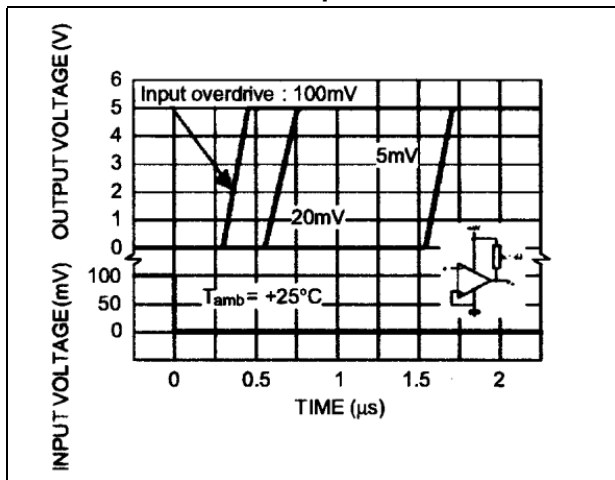

Figure 6. Response time for various input overdrives - positive transition



4 Application information

4.1 Typical applications

Figure 7. Basic comparator

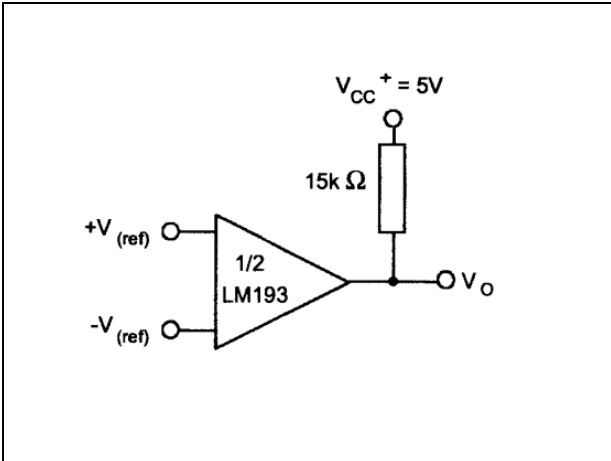

Figure 8. Driving CMOS

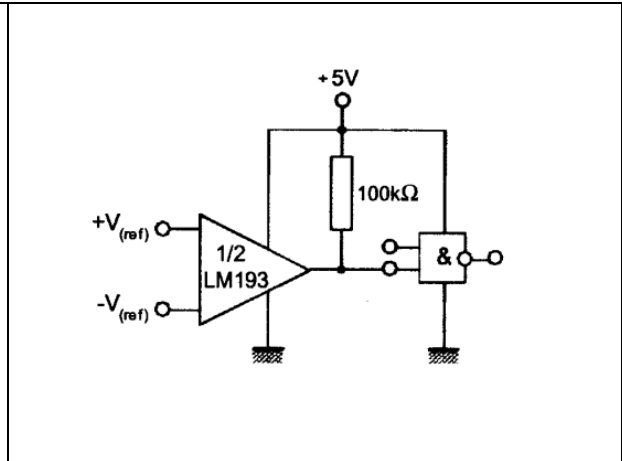

Figure 9. Driving TTL

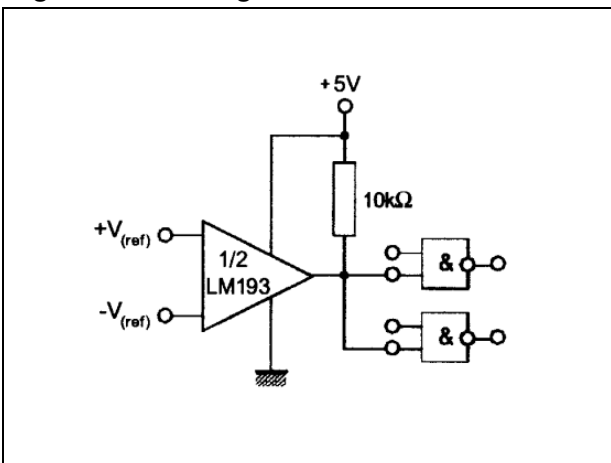

Figure 10. Low-frequency op-amp

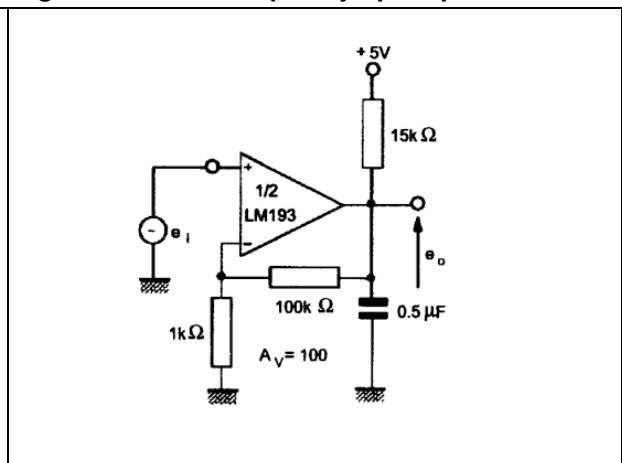

Figure 11. Low-frequency op-amp

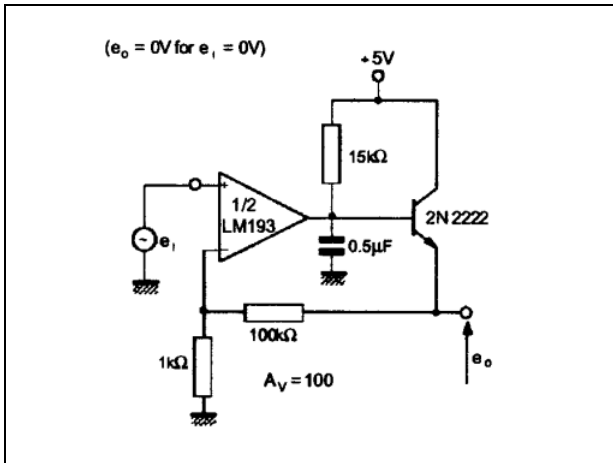

Figure 12. Transducer amplifier

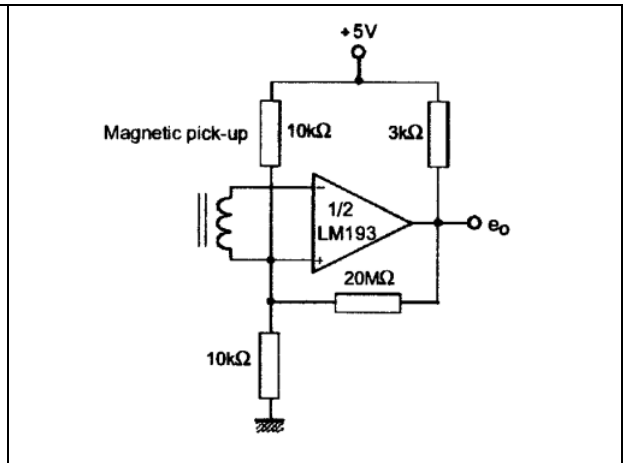

Figure 13. Low frequency op-amp with offset adjust

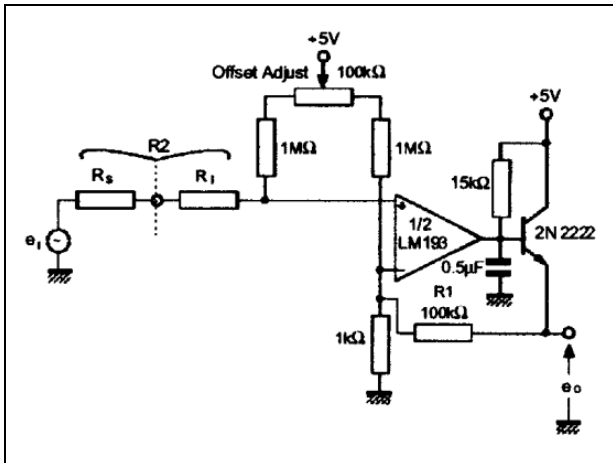

Figure 14. Zero crossing detector (single power supply)

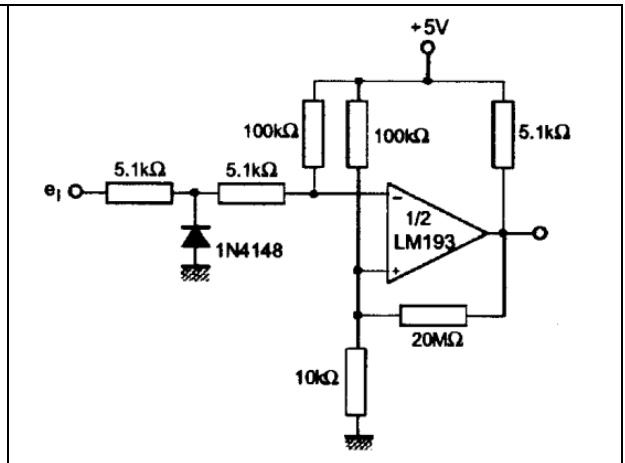

Figure 15. Two decades high-frequency VCO

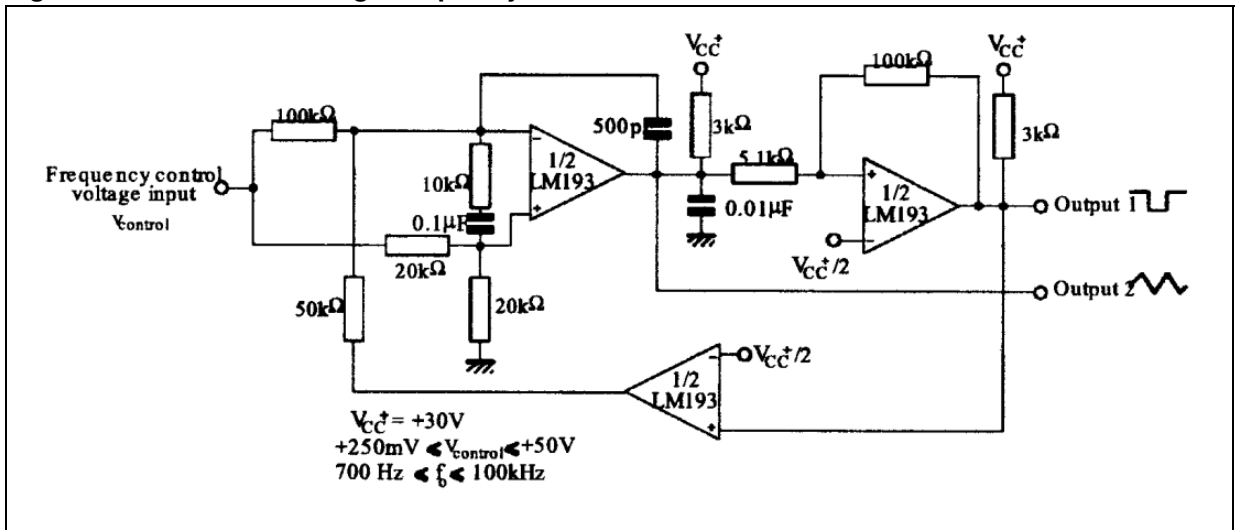

Figure 16. Limit comparator

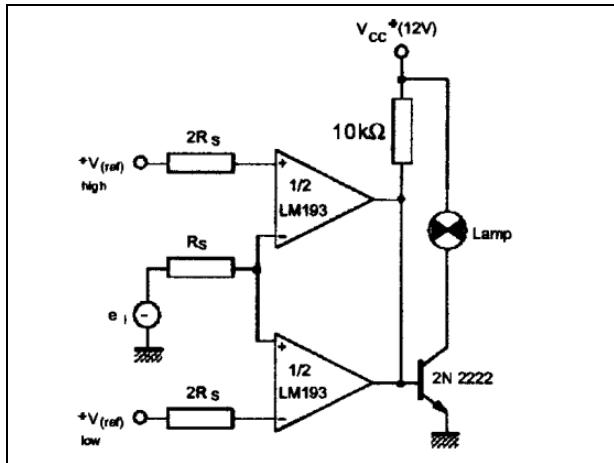
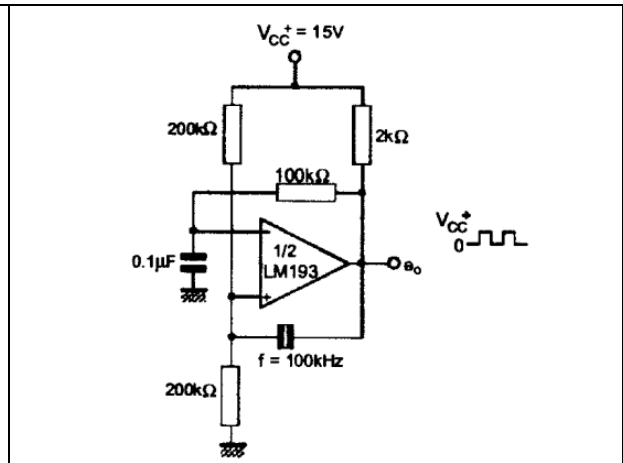

Figure 17. Crystal controlled oscillator



4.2 Split-supply applications

Figure 18. Zero crossing detector

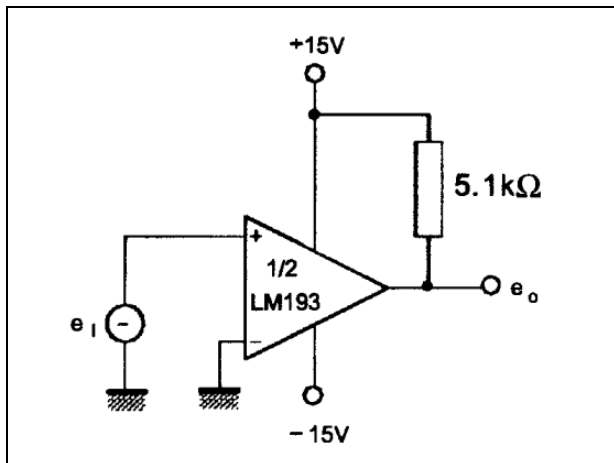
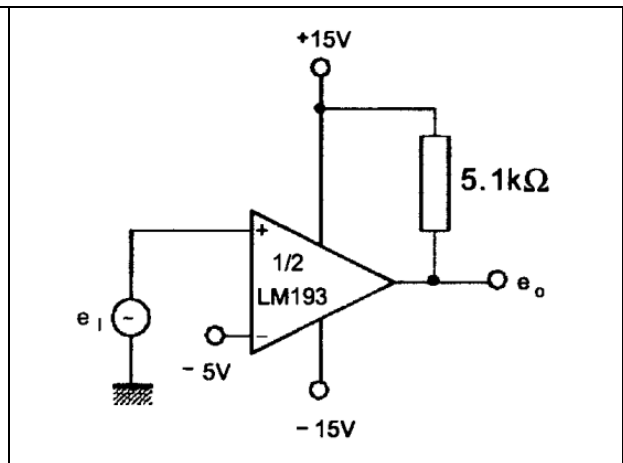

Figure 19. Comparator with a negative reference



5 Package information

In order to meet environmental requirements, ST offers these devices in different grades of ECOPACK® packages, depending on their level of environmental compliance. ECOPACK® specifications, grade definitions and product status are available at: www.st.com. ECOPACK® is an ST trademark.

5.1 DIP8 package information

Figure 20. DIP8 package mechanical drawing

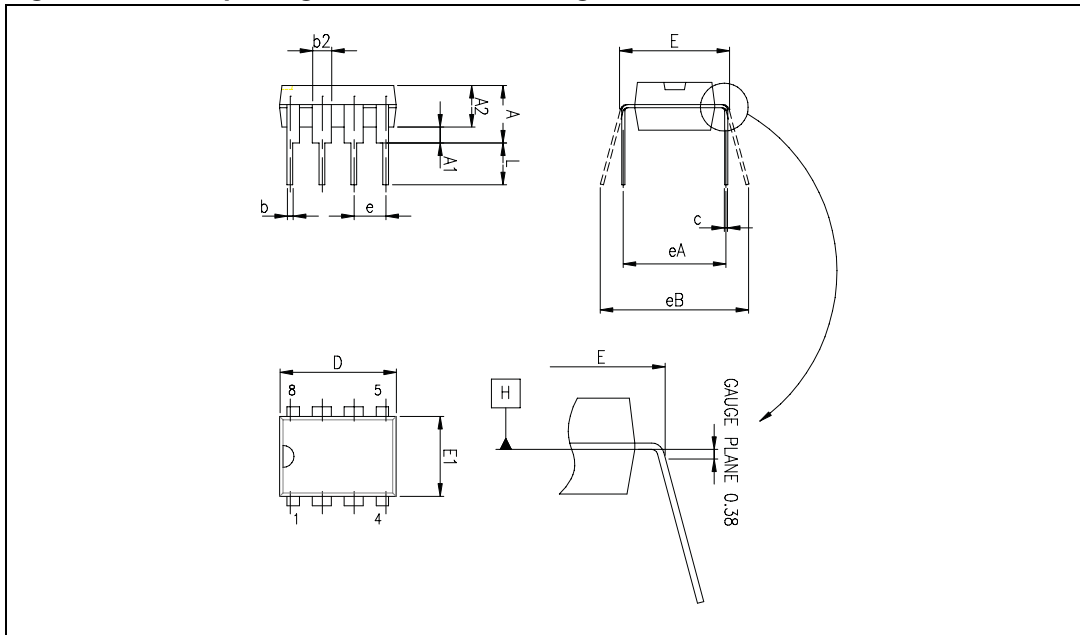

Table 4. DIP8 package mechanical data

Ref.	Dimensions					
	Millimeters			Inches		
	Min.	Typ.	Max.	Min.	Typ.	Max.
A			5.33			0.210
A1	0.38			0.015		
A2	2.92	3.30	4.95	0.115	0.130	0.195
b	0.36	0.46	0.56	0.014	0.018	0.022
b2	1.14	1.52	1.78	0.045	0.060	0.070
c	0.20	0.25	0.36	0.008	0.010	0.014
D	9.02	9.27	10.16	0.355	0.365	0.400
E	7.62	7.87	8.26	0.300	0.310	0.325
E1	6.10	6.35	7.11	0.240	0.250	0.280
e		2.54			0.100	
eA		7.62			0.300	
eB			10.92			0.430
L	2.92	3.30	3.81	0.115	0.130	0.150

5.2 SO-8 package information

Figure 21. SO-8 package mechanical drawing

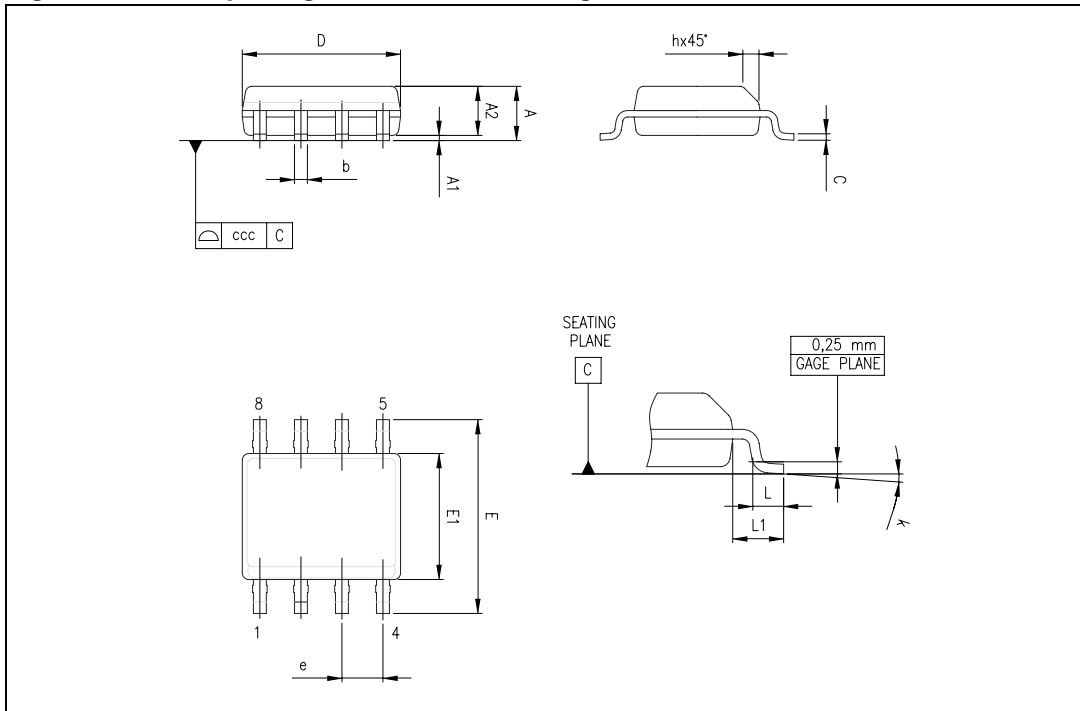

Table 5. SO-8 package mechanical data

Ref.	Dimensions					
	Millimeters			Inches		
	Min.	Typ.	Max.	Min.	Typ.	Max.
A			1.75			0.069
A1	0.10		0.25	0.004		0.010
A2	1.25			0.049		
b	0.28		0.48	0.011		0.019
c	0.17		0.23	0.007		0.010
D	4.80	4.90	5.00	0.189	0.193	0.197
E	5.80	6.00	6.20	0.228	0.236	0.244
E1	3.80	3.90	4.00	0.150	0.154	0.157
e		1.27			0.050	
h	0.25		0.50	0.010		0.020
L	0.40		1.27	0.016		0.050
L1		1.04			0.040	
k	0		8°	1°		8°
ccc			0.10			0.004

5.3 TSSOP8 package information

Figure 22. TSSOP8 package mechanical drawing

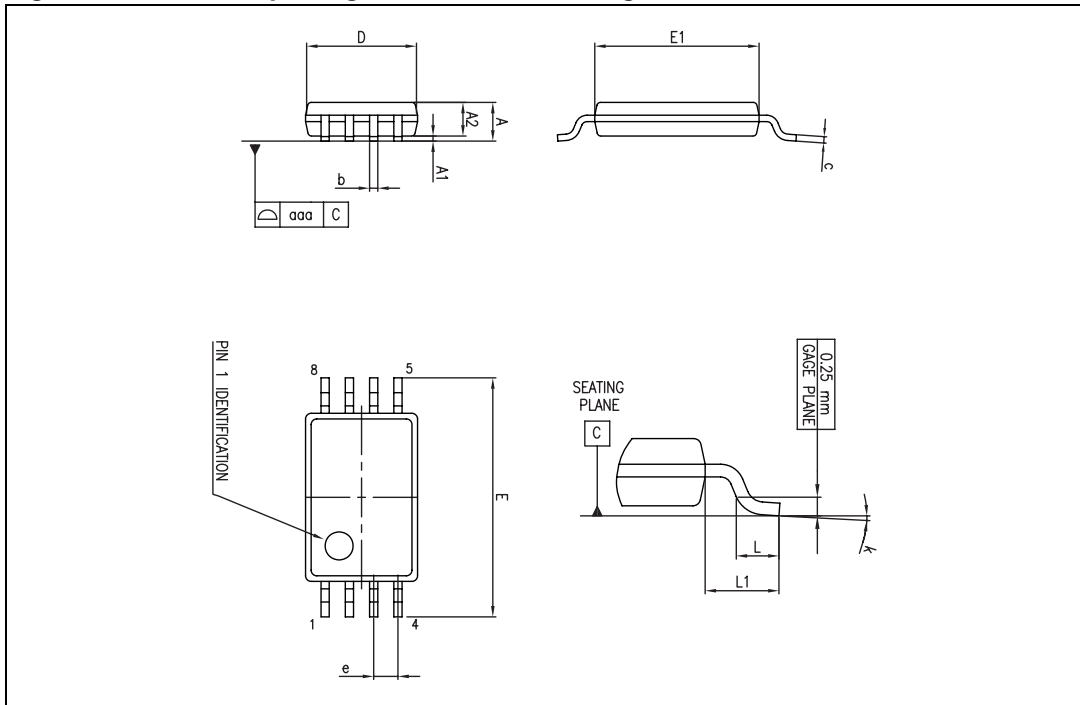

Table 6. TSSOP8 package mechanical data

Ref.	Dimensions					
	Millimeters			Inches		
	Min.	Typ.	Max.	Min.	Typ.	Max.
A			1.20			0.047
A1	0.05		0.15	0.002		0.006
A2	0.80	1.00	1.05	0.031	0.039	0.041
b	0.19		0.30	0.007		0.012
c	0.09		0.20	0.004		0.008
D	2.90	3.00	3.10	0.114	0.118	0.122
E	6.20	6.40	6.60	0.244	0.252	0.260
E1	4.30	4.40	4.50	0.169	0.173	0.177
e		0.65			0.0256	
k	0°		8°	0°		8°
L	0.45	0.60	0.75	0.018	0.024	0.030
L1		1			0.039	
aaa			0.10			0.004

6 Ordering information

Table 7. Order codes

Part number	Temperature range	Package	Packing	Marking
LM193WD LM193WDT	-55°C, +125°C	SO-8	Tube or Tape & reel	193W
LM193WN		DIP8	Tube	LM193WN
LM193WPT		TSSOP8	Tape & reel	193W
LM293WD LM293WDT	-40°C, +105°C	SO-8	Tube or Tape & reel	293W
LM293WN		DIP8	Tube	LM293WN
LM293WPT		TSSOP8	Tape & reel	293W
LM293WYD ⁽¹⁾ LM293WYDT ⁽¹⁾	-40°C, +105°C	SO-8 Automotive grade	Tube or Tape & reel	293WY
LM293WYPT ⁽²⁾		TSSOP8 Automotive grade	Tape & reel	293WY
LM393WD LM393WDT	0°C, +70°C	SO-8	Tube or Tape & reel	393W
LM393WN		DIP8	Tube	LM393WN
LM393WPT		TSSOP8	Tape & reel	393W
LM393WYD ⁽¹⁾ LM393WYDT ⁽¹⁾	0°C, +70°C	SO-8 Automotive grade	Tube or Tape & reel	393WY
LM393WYPT ⁽²⁾		TSSOP8 Automotive grade	Tape & reel	393WY

1. Qualified and characterized according to AEC Q100 and Q003 or equivalent, advanced screening according to AEC Q001 & Q 002 or equivalent.
2. Qualification and characterization according to AEC Q100 and Q003 or equivalent, advanced screening according to AEC Q001 & Q 002 or equivalent are on-going.

7 Revision history

Table 8. Document revision history

Date	Revision	Changes
12-May-2004	1	Initial release.
11-Dec-2008	2	Updated document format. Added ESD parameters in Table 1: Absolute maximum ratings . Added values for R_{thja} and R_{thjc} in Table 1: Absolute maximum ratings . Added junction temperature T_j in Table 1: Absolute maximum ratings . Deleted power dissipation P_D in Table 1: Absolute maximum ratings . Updated ECOPACK® information in Chapter 5 . Corrected DIP8 package information in Section 5.1 . Added automotive grade products in Table 7: Order codes .

Please Read Carefully:

Information in this document is provided solely in connection with ST products. STMicroelectronics NV and its subsidiaries ("ST") reserve the right to make changes, corrections, modifications or improvements, to this document, and the products and services described herein at any time, without notice.

All ST products are sold pursuant to ST's terms and conditions of sale.

Purchasers are solely responsible for the choice, selection and use of the ST products and services described herein, and ST assumes no liability whatsoever relating to the choice, selection or use of the ST products and services described herein.

No license, express or implied, by estoppel or otherwise, to any intellectual property rights is granted under this document. If any part of this document refers to any third party products or services it shall not be deemed a license grant by ST for the use of such third party products or services, or any intellectual property contained therein or considered as a warranty covering the use in any manner whatsoever of such third party products or services or any intellectual property contained therein.

UNLESS OTHERWISE SET FORTH IN ST'S TERMS AND CONDITIONS OF SALE ST DISCLAIMS ANY EXPRESS OR IMPLIED WARRANTY WITH RESPECT TO THE USE AND/OR SALE OF ST PRODUCTS INCLUDING WITHOUT LIMITATION IMPLIED WARRANTIES OF MERCHANTABILITY, FITNESS FOR A PARTICULAR PURPOSE (AND THEIR EQUIVALENTS UNDER THE LAWS OF ANY JURISDICTION), OR INFRINGEMENT OF ANY PATENT, COPYRIGHT OR OTHER INTELLECTUAL PROPERTY RIGHT.

UNLESS EXPRESSLY APPROVED IN WRITING BY AN AUTHORIZED ST REPRESENTATIVE, ST PRODUCTS ARE NOT RECOMMENDED, AUTHORIZED OR WARRANTED FOR USE IN MILITARY, AIR CRAFT, SPACE, LIFE SAVING, OR LIFE SUSTAINING APPLICATIONS, NOR IN PRODUCTS OR SYSTEMS WHERE FAILURE OR MALFUNCTION MAY RESULT IN PERSONAL INJURY, DEATH, OR SEVERE PROPERTY OR ENVIRONMENTAL DAMAGE. ST PRODUCTS WHICH ARE NOT SPECIFIED AS "AUTOMOTIVE GRADE" MAY ONLY BE USED IN AUTOMOTIVE APPLICATIONS AT USER'S OWN RISK.

Resale of ST products with provisions different from the statements and/or technical features set forth in this document shall immediately void any warranty granted by ST for the ST product or service described herein and shall not create or extend in any manner whatsoever, any liability of ST.

ST and the ST logo are trademarks or registered trademarks of ST in various countries.

Information in this document supersedes and replaces all information previously supplied.

The ST logo is a registered trademark of STMicroelectronics. All other names are the property of their respective owners.

© 2008 STMicroelectronics - All rights reserved

STMicroelectronics group of companies

Australia - Belgium - Brazil - Canada - China - Czech Republic - Finland - France - Germany - Hong Kong - India - Israel - Italy - Japan - Malaysia - Malta - Morocco - Singapore - Spain - Sweden - Switzerland - United Kingdom - United States of America

www.st.com

