



Chipsmall Limited consists of a professional team with an average of over 10 year of expertise in the distribution of electronic components. Based in Hongkong, we have already established firm and mutual-benefit business relationships with customers from,Europe,America and south Asia,supplying obsolete and hard-to-find components to meet their specific needs.

With the principle of “Quality Parts,Customers Priority,Honest Operation,and Considerate Service”,our business mainly focus on the distribution of electronic components. Line cards we deal with include Microchip,ALPS,ROHM,Xilinx,Pulse,ON,Everlight and Freescale. Main products comprise IC,Modules,Potentiometer,IC Socket,Relay,Connector.Our parts cover such applications as commercial,industrial, and automotives areas.

We are looking forward to setting up business relationship with you and hope to provide you with the best service and solution. Let us make a better world for our industry!



## Contact us

Tel: +86-755-8981 8866 Fax: +86-755-8427 6832

Email & Skype: info@chipsmall.com Web: www.chipsmall.com

Address: A1208, Overseas Decoration Building, #122 Zhenhua RD., Futian, Shenzhen, China



Operational Amplifiers

# Low Noise Operational Amplifier

## LM4559xxx

**General Description**

The LM4559xxx are low noise operational amplifiers with high gain and wide bandwidth. They have good performance of input referred noise voltage ( $5\text{ nV}/\sqrt{\text{Hz}}$ ) and total harmonic distortion (0.0003%). These are suitable for audio applications and active filter.

**Features**

- High Voltage Gain
- High Slew Rate
- Low Noise Voltage
- Low Total Harmonic Distortion
- Low Power Consumption

**Application**

- Audio Application
- Consumer Equipment
- Active Filter

**Key Specifications**

- Operating Supply Voltage:  $\pm 4\text{V to } \pm 18\text{V}$
- Temperature Range:  $-40^\circ\text{C to } +85^\circ\text{C}$
- Voltage Gain: 110dB (Typ)
- Unity Gain Bandwidth: 3.3MHz (Typ)
- Slew Rate:  $3.5\text{ V}/\mu\text{s}$  (Typ)
- Input Referred Noise Voltage:  $5\text{ nV}/\sqrt{\text{Hz}}$  (Typ)

**Package**

Package	W(Typ) xD(Typ) xH(Max)
SOP-8	5.00mm x 6.20mm x 1.71mm
SOP-J8	4.90mm x 6.00mm x 1.65mm
SSOP-B8	3.00mm x 6.40mm x 1.35mm
TSSOP-B8	3.00mm x 6.40mm x 1.20mm
MSOP8	2.90mm x 4.00mm x 0.90mm
TSSOP-B8J	3.00mm x 4.90mm x 1.10mm

**Simplified Schematic**

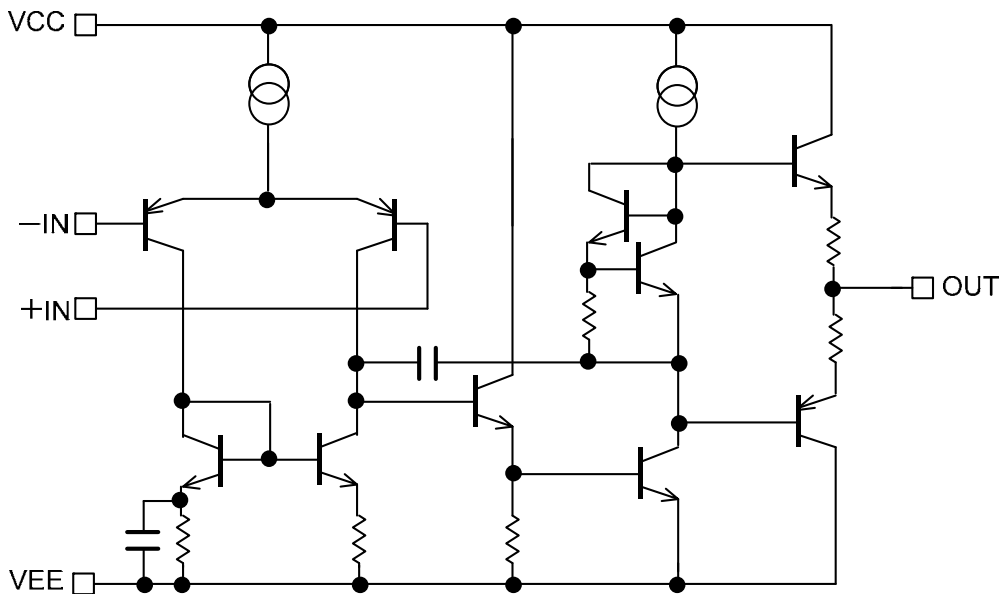
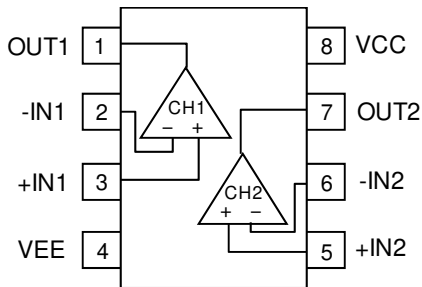

Figure 1. Simplified Schematic (1 channel only)

○Product structure : Silicon monolithic integrated circuit ○This product has no designed protection against radioactive rays.

Pin Configuration

LM4559F : SOP8  
 LM4559FJ : SOP-J8  
 LM4559FV : SSOP-B8  
 LM4559FVT : TSSOP-B8  
 LM4559FVM : MSOP8  
 LM4559FVJ : TSSOP-B8J



Pin No.	Symbol
1	OUT1
2	-IN1
3	+IN1
4	VEE
5	+IN2
6	-IN2
7	OUT2
8	VCC

Ordering Information

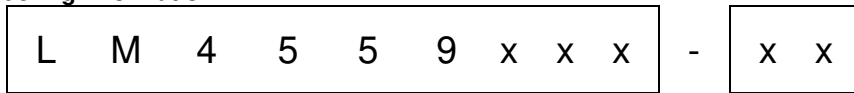

Part Number LM4559xxx	Package F : SOP8 FJ : SOP-J8 FV : SSOP-B8 FVT : TSSOP-B8 FVM : MSOP8 FVJ : TSSOP-B8J	Packaging and forming specification E2: Embossed tape and reel (SOP8/SOP-J8/SSOP-B8/TSSOP-B8/TSSOP-B8J) TR: Embossed tape and reel (MSOP8)
--------------------------	--	--

Line-up

$T_{opr}$	Package		Operable Part Number
-40°C to +85°C	SOP8	Reel of 2500	LM4559F-E2
	SOP-J8	Reel of 2500	LM4559FJ-E2
	SSOP-B8	Reel of 2500	LM4559FV-E2
	TSSOP-B8	Reel of 3000	LM4559FVT-E2
	MSOP8	Reel of 3000	LM4559FVM-TR
	TSSOP-B8J	Reel of 2500	LM4559FVJ-E2

Absolute Maximum Ratings ( $T_A=25^\circ\text{C}$ )

Parameter	Symbol	Rating	Unit	
Supply Voltage	VCC – VEE	+36	V	
Power Dissipation	$P_D$	SOP8	0.68 <sup>(Note 1,5)</sup>	W
		SOP-J8	0.67 <sup>(Note 2,5)</sup>	
		SSOP-B8	0.62 <sup>(Note 3,5)</sup>	
		TSSOP-B8	0.62 <sup>(Note 3,5)</sup>	
		MSOP8	0.58 <sup>(Note 4,5)</sup>	
		TSSOP-B8J	0.58 <sup>(Note 4,5)</sup>	
Differential Input Voltage <sup>(Note 6)</sup>	$V_{ID}$	+36	V	
Input Common-mode Voltage Range	$V_{ICM}$	(VEE - 0.3) to (VEE + 36)	V	
Operating Supply Voltage	$V_{opr}$	$\pm 4$ to $\pm 18$	V	
Operating Temperature	$T_{opr}$	-40 to +85	$^\circ\text{C}$	
Storage Temperature	$T_{stg}$	-55 to +150	$^\circ\text{C}$	
Maximum Junction Temperature	$T_{Jmax}$	+150	$^\circ\text{C}$	

(Note 1) When used at temperature above  $T_A = 25^\circ\text{C}$ , reduce by 5.5mW/ $^\circ\text{C}$ .

(Note 2) When used at temperature above  $T_A = 25^\circ\text{C}$ , reduce by 5.4mW/ $^\circ\text{C}$ .

(Note 3) When used at temperature above  $T_A = 25^\circ\text{C}$ , reduce by 5.0mW/ $^\circ\text{C}$ .

(Note 4) When used at temperature above  $T_A = 25^\circ\text{C}$ , reduce by 4.7mW/ $^\circ\text{C}$ .

(Note 5) Mounted on a FR4 glass epoxy PCB(70mm×70mm×1.6mm).

(Note 6) The differential input voltage is the voltage difference between inverting input and non-inverting input. Input terminal voltage is set to more than VEE.

Caution: Absolute maximum rating of each item indicates the condition which must not be exceeded.

Application of voltage in excess of absolute maximum rating or usage out of absolute maximum rated temperature environment may cause deterioration of characteristics.

**Electrical Characteristics:**

OLM4559xxx (Unless otherwise specified VCC=+15V, VEE=-15V)

Parameter	Symbol	Temperature Range	Limit			Unit	Conditions
			Min	Typ	Max		
Input Offset Voltage <sup>(Note 7)</sup>	V <sub>IO</sub>	25°C	-	0.5	1.5	mV	OUT=0V
Input Offset Current <sup>(Note 7)</sup>	I <sub>IO</sub>	25°C	-	5	100	nA	OUT=0V
Input Bias Current <sup>(Note 7)</sup>	I <sub>B</sub>	25°C	-	40	250	nA	OUT=0V
Supply Current <sup>(Note 8)</sup>	I <sub>CC</sub>	25°C	-	3.3	5.0	mA	R <sub>L</sub> =∞, All Op-Amps
		Full range	-	-	6.5		
Large Signal Voltage Gain	A <sub>v</sub>	25°C	20	300	-	V/mV	OUT=±10V, R <sub>L</sub> =2kΩ
		25°C	86	110	-	dB	
Maximum Output Voltage	V <sub>OM</sub>	25°C	±12	±13	-	V	R <sub>L</sub> ≥2kΩ
			±11	±12.5	-		R <sub>L</sub> =600Ω
Maximum Output Swing Bandwidth	B <sub>OM</sub>	25°C	-	32	-	kHz	OUT=20V <sub>P-P</sub> , R <sub>L</sub> =2kΩ
Input Common-mode Voltage Range	V <sub>ICM</sub>	25°C	±12	±13	-	V	—
Common-mode Rejection Ratio	CMRR	25°C	80	100	-	dB	OUT=0V
Power Supply Rejection Ratio	PSRR	25°C	82	100	-	dB	OUT=0V
Slew Rate	SR	25°C	1.5	3.5	-	V/μs	R <sub>L</sub> =2kΩ, C <sub>L</sub> =100pF
Unity Gain Frequency	f <sub>T</sub>	25°C	-	3.3	-	MHz	R <sub>L</sub> =2kΩ
Gain Bandwidth	GBW	25°C	-	4	-	MHz	R <sub>L</sub> =2kΩ, f=1MHz
Phase Margin	θ	25°C	-	50	-	deg	R <sub>L</sub> =2kΩ
Input Referred Noise Voltage	V <sub>N</sub>	25°C	-	0.7	-	μVrms	A <sub>v</sub> = 40dB, R <sub>S</sub> =1kΩ f=20Hz to 20kHz
			-	5	-	nV/√Hz	A <sub>v</sub> = 40dB, V <sub>ICM</sub> =0V f=1kHz
Total Harmonic Distortion + Noise	THD+N	25°C	-	0.0003	-	%	A <sub>v</sub> = 20dB f=1kHz, R <sub>L</sub> =2kΩ OUT= 5Vrms
Channel Separation	CS	25°C	-	110	-	dB	A <sub>v</sub> =40dB, f=1kHz OUT=1Vrms

(Note 7) Absolute value.

(Note 8) Full range: T<sub>A</sub>=-40°C to +85°C

### Description of Electrical Characteristics

Described here are the terms of electric characteristics used in this datasheet. Items and symbols used are also shown. Note that item name, symbol and their meaning may differ from those on other manufacturer's document or general documents.

#### 1. Absolute maximum ratings

Absolute maximum rating items indicate the condition which must not be exceeded. Application of voltage in excess of absolute maximum rating or use out of absolute maximum rated temperature environment may cause deterioration of characteristics.

- (1) Supply Voltage (VCC/VEE)  
Indicates the maximum voltage that can be applied between the positive power supply terminal and negative power supply terminal without deterioration or destruction of characteristics of internal circuit.
- (2) Differential Input Voltage (V<sub>ID</sub>)  
Indicates the maximum voltage that can be applied between non-inverting and inverting terminals without damaging the IC.
- (3) Input Common-mode Voltage Range (V<sub>ICM</sub>)  
Indicates the maximum voltage that can be applied to the non-inverting and inverting terminals without deterioration or destruction of electrical characteristics. Input common-mode voltage range of the maximum ratings does not assure normal operation of IC. For normal operation, use the IC within the input common-mode voltage range characteristics.
- (4) Power dissipation (P<sub>D</sub>)  
Indicates the power that can be consumed by the IC when mounted on a specific board at the ambient temperature 25°C (normal temperature). As for package product, P<sub>d</sub> is determined by the temperature that can be permitted by the IC in the package (maximum junction temperature) and the thermal resistance of the package.

#### 2. Electrical characteristics item

- (1) Input Offset Voltage (V<sub>IO</sub>)  
Indicates the voltage difference between non-inverting terminal and inverting terminals. It can be translated into the input voltage difference required for setting the output voltage at 0 V.
- (2) Input Offset Current (I<sub>IO</sub>)  
Indicates the difference of input bias current between the non-inverting and inverting terminals.
- (3) Input Bias Current (I<sub>B</sub>)  
Indicates the current that flows into or out of the input terminal. It is defined by the average of input bias currents at the non-inverting and inverting terminals.
- (4) Input Common-mode Voltage Range (V<sub>ICM</sub>)  
Indicates the input voltage range where IC operates normally.
- (5) Maximum Output Voltage (V<sub>OM</sub>)  
Indicates the voltage range that the IC can output under specified load condition. It is typically divided into high-level output voltage and low-level output voltage. High-level output voltage indicates the upper limit of output voltage. Low-level output voltage indicates the lower limit.
- (6) Large Signal Voltage Gain (A<sub>v</sub>)  
Indicates the amplifying rate (gain) of output voltage against the voltage difference between non-inverting terminal and inverting terminal. It is normally the amplifying rate (gain) with reference to DC voltage.  
$$A_v = (\text{Output voltage}) / (\text{Differential Input voltage})$$
- (7) Supply Current (I<sub>CC</sub>)  
Indicates the current that flows within the IC under specified no-load conditions.
- (8) Output Source Current/ Output Sink Current (I<sub>source</sub> / I<sub>sink</sub>)  
The maximum current that can be output from the IC under specific output conditions. The output source current indicates the current flowing out from the IC, and the output sink current indicates the current flowing into the IC.
- (9) Unity Gain Frequency (f<sub>T</sub>)  
Indicates a frequency where the voltage gain of operational amplifier is 1.
- (10) Gain Bandwidth (GBW)  
Indicates to multiply by the frequency and the gain where the voltage gain decreases 6dB/octave.
- (11) Phase Margin (θ)  
Indicates the margin of phase from 180 degree phase lag at unity gain frequency.
- (12) Common-mode Rejection Ratio (CMRR)  
Indicates the ratio of fluctuation of input offset voltage when the input common-mode voltage is changed. It is normally the fluctuation of DC.  
$$\text{CMRR} = (\text{Change of Input common-mode voltage}) / (\text{Input offset fluctuation})$$
- (13) Power Supply Rejection Ratio (PSRR)  
Indicates the ratio of fluctuation of input offset voltage when supply voltage is changed. It is normally the fluctuation of DC.  
$$\text{PSRR} = (\text{Change of power supply voltage}) / (\text{Input offset fluctuation})$$
- (14) Input Referred Noise Voltage (V<sub>N</sub>)  
Indicates a noise voltage generated inside the operational amplifier reflected back to an ideal voltage source connected in series with the input terminal.
- (15) Total Harmonic Distortion + Noise (THD+N)  
Indicates the fluctuation of input offset voltage or that of output voltage with reference to the change of output voltage of driven channel.

- (16) Channel Separation (CS)  
Indicates the fluctuation in the output voltage of the driven channel with reference to the change of output voltage of the channel which is not driven.
- (17) Slew Rate (SR)  
Indicates the ratio of the change in output voltage with time when a step input signal is applied.

Typical Performance Curves  
OLM4559xxx

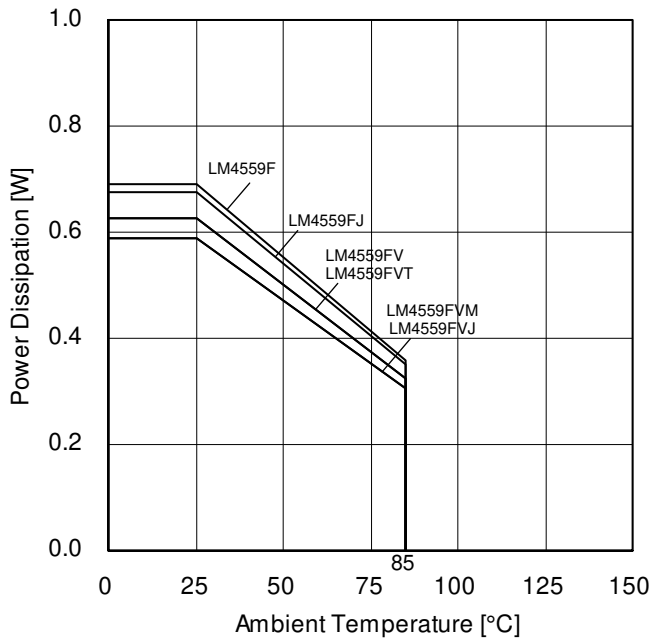

Figure 2.  
Power Dissipation vs Ambient Temperature  
(Derating Curve)

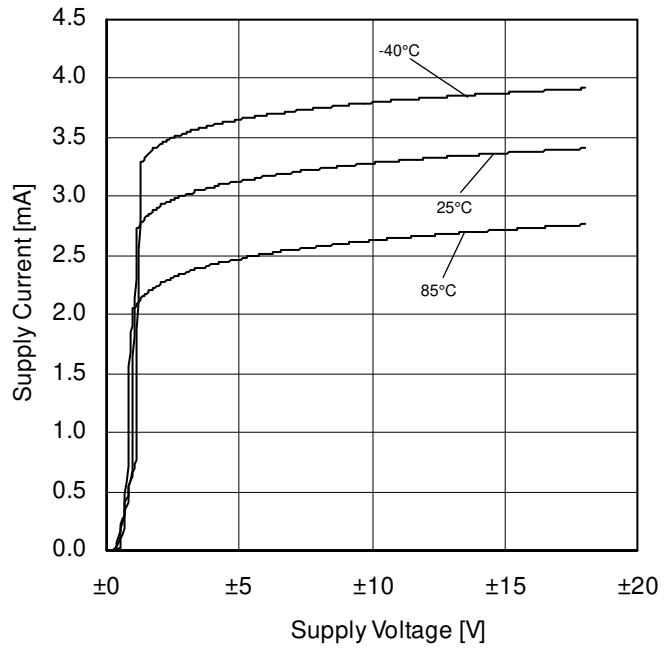

Figure 3.  
Supply Current vs Supply Voltage

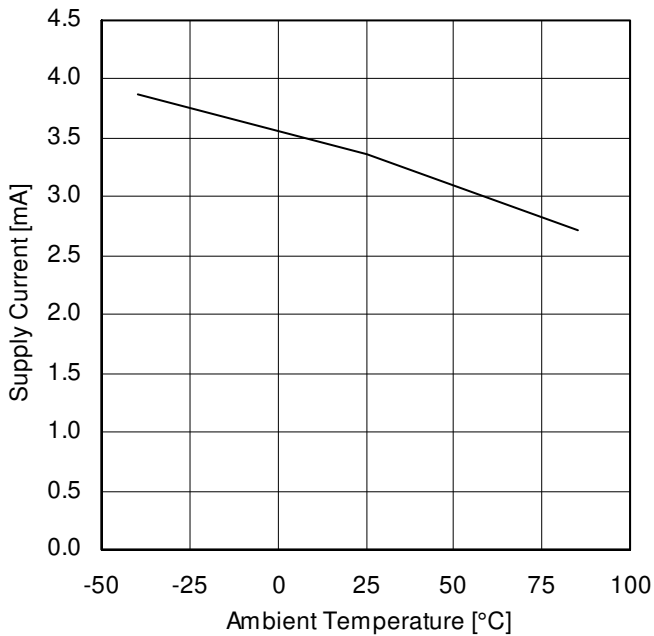

Figure 4.  
Supply Current vs Ambient Temperature  
(VCC/VEE=±15V)

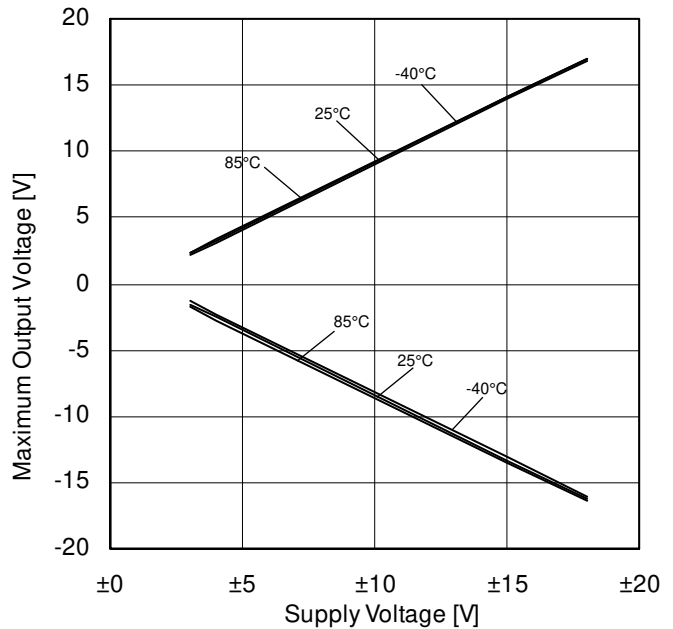

Figure 5.  
Maximum Output Voltage vs Supply Voltage  
( $R_L=2k\Omega$ )

(\*)The data above is measurement value of typical sample, it is not guaranteed.

Typical Performance Curves (Reference data) – continued  
OLM4559xxx

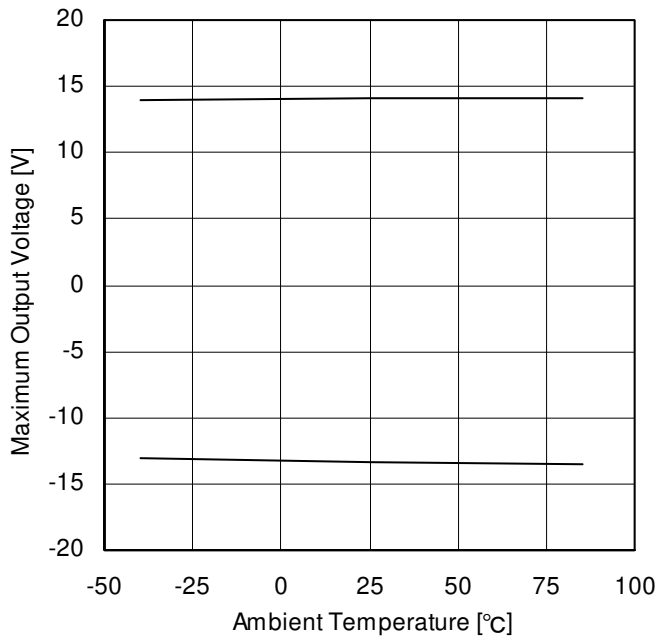

Figure 6.  
Maximum Output Voltage vs Ambient Temperature  
(VCC/VEE=±15V, RL=2kΩ)

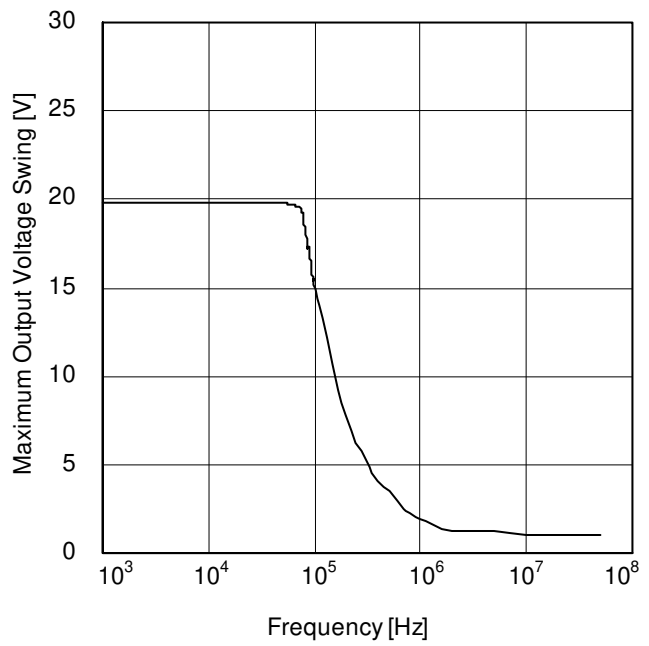

Figure 7.  
Maximum Output Voltage Swing vs Frequency  
(VCC/VEE=±15V, TA=25°C, RL=2kΩ)

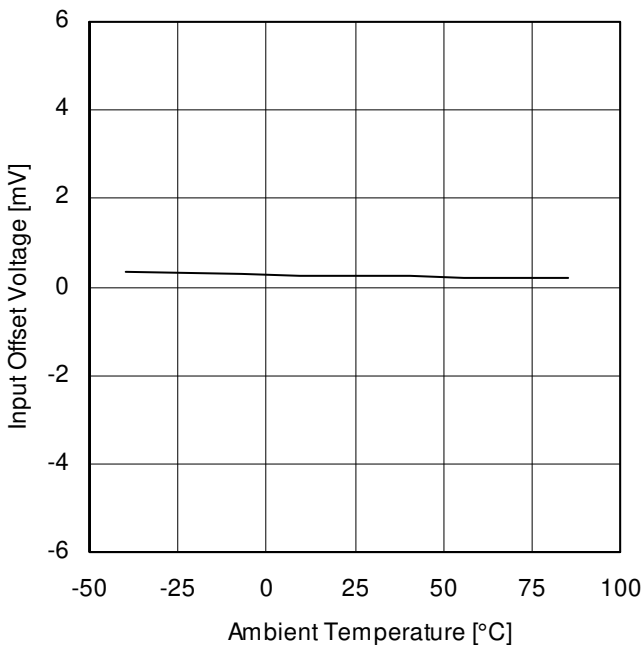

Figure 8.  
Input Offset Voltage vs Ambient Temperature  
(VCC/VEE=±15V)

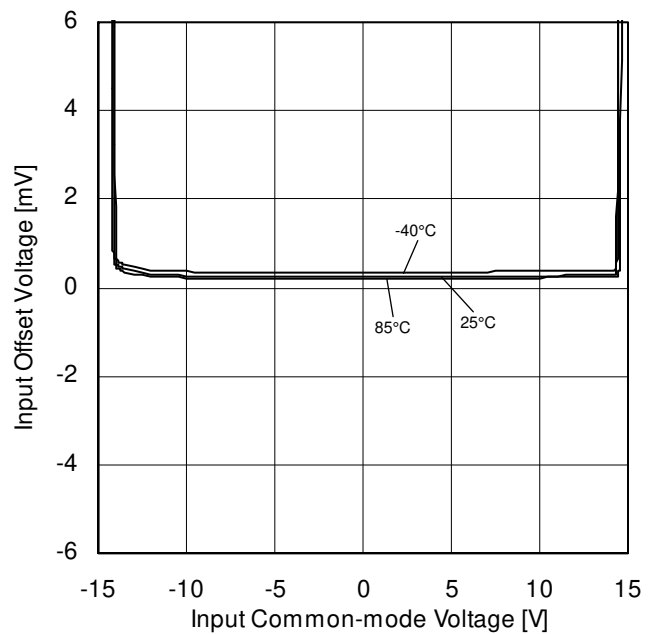

Figure 9.  
Input Offset Voltage vs Input Common-mode Voltage  
(VCC/VEE=±15V)

(\*The data above is measurement value of typical sample, it is not guaranteed.

Typical Performance Curves (Reference data) – continued  
OLM4559xxx

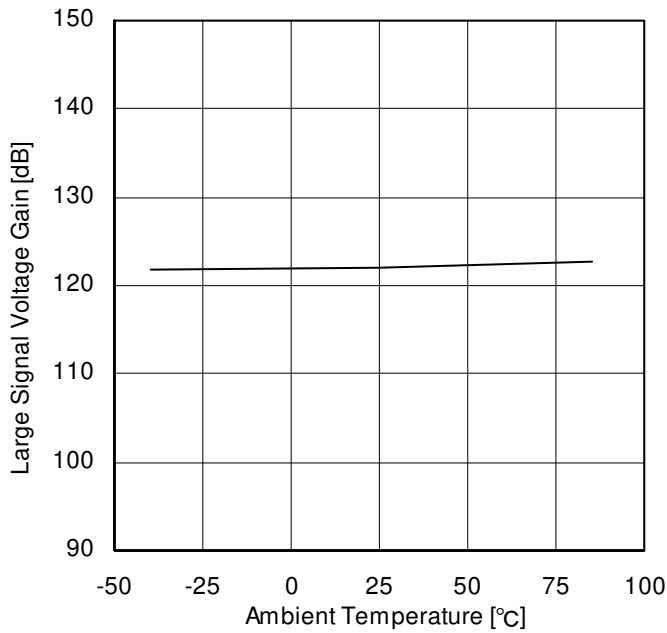

Figure 10.  
Large Signal Voltage Gain vs Ambient Temperature  
(VCC/VEE=±15V, RL=2kΩ)

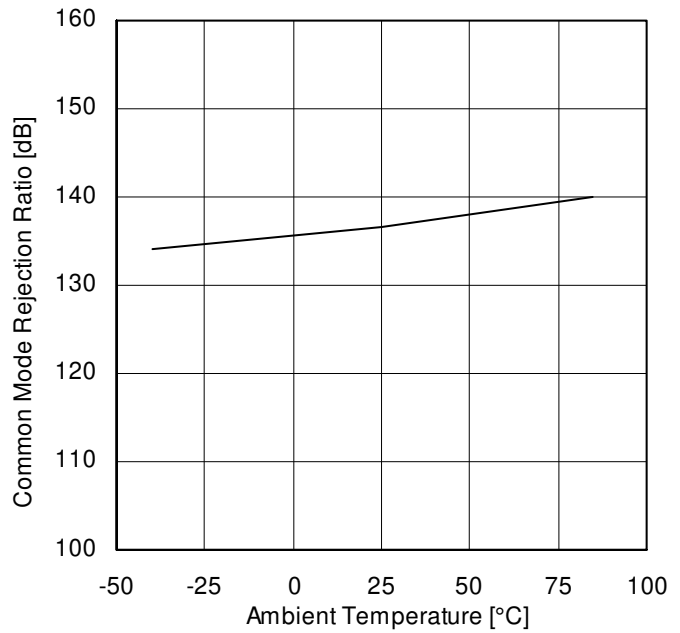

Figure 11.  
Common Mode Rejection Ratio vs Ambient Temperature  
(VCC/VEE=±15V)

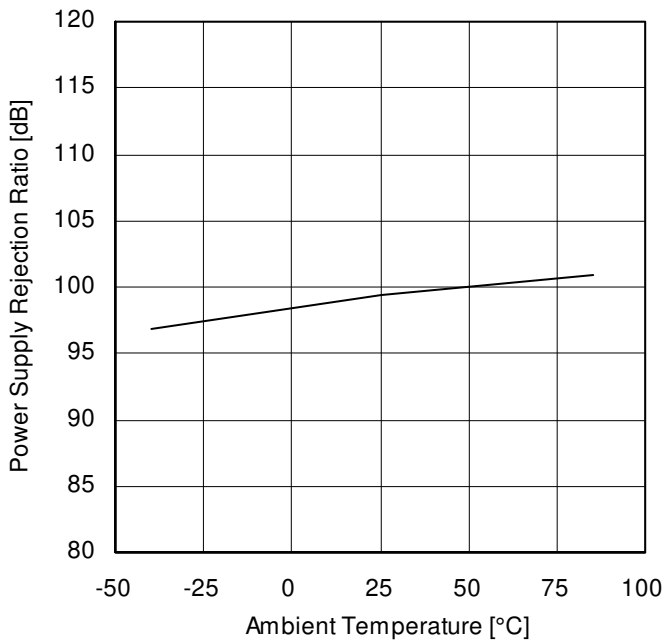

Figure 12.  
Power Supply Rejection Ratio vs Ambient Temperature

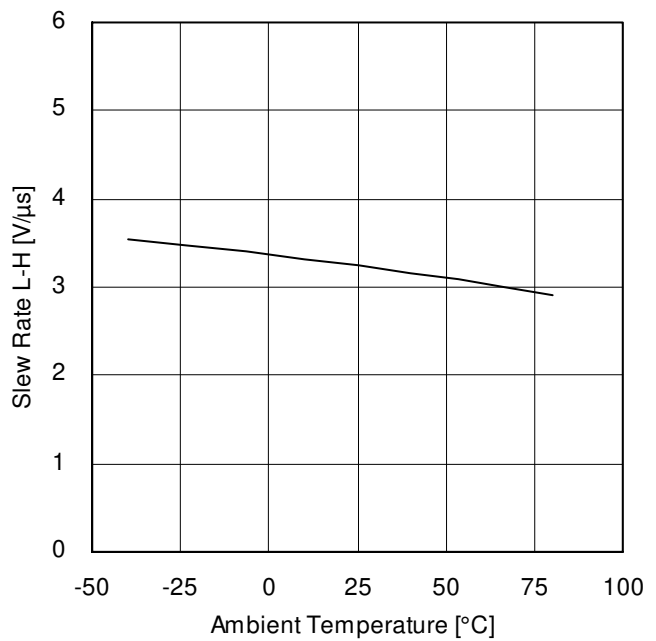

Figure 13.  
Slew Rate L-H vs Ambient Temperature  
(VCC/VEE=±15V, RL=2kΩ, CL=100pF)

(\*)The data above is measurement value of typical sample, it is not guaranteed.

Typical Performance Curves (Reference data) - continued  
OLM4559xxx

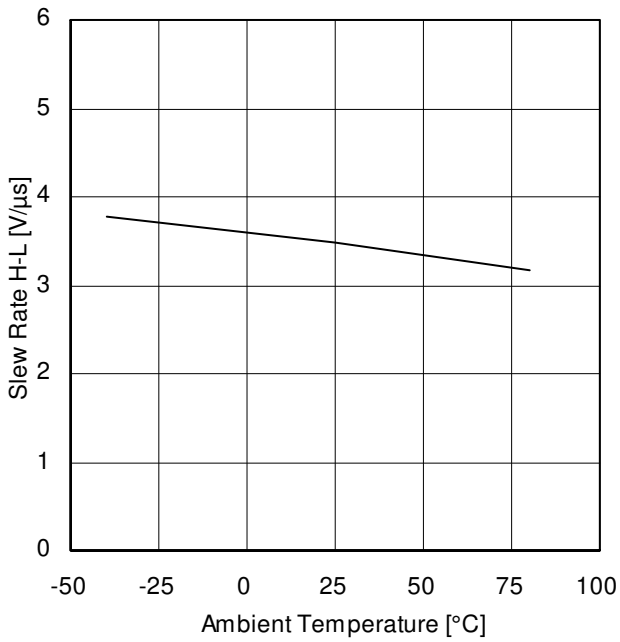

Figure 14.  
Slew Rate H-L vs Ambient Temperature  
(VCC/VEE=±15V, R<sub>L</sub>=2kΩ, C<sub>L</sub>=100pF)

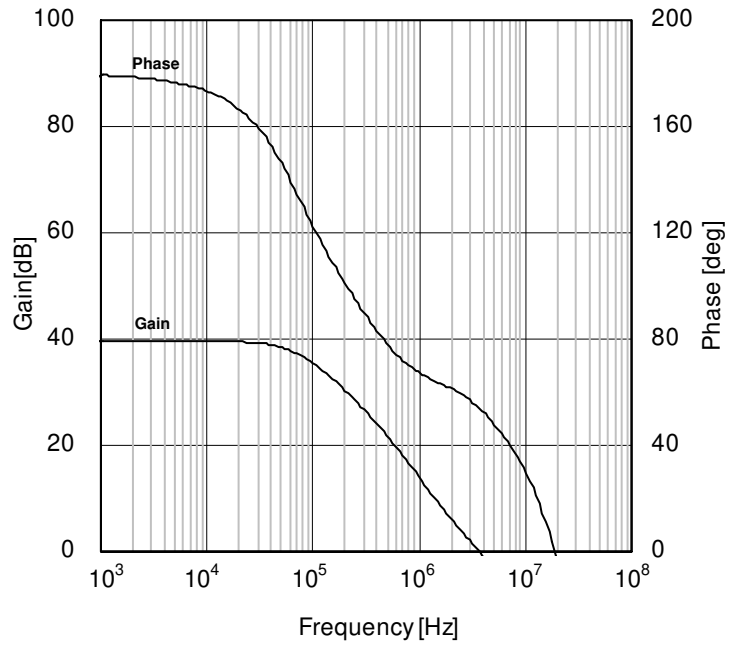

Figure 15.  
Voltage Gain · Phase vs Frequency  
(VCC/VEE=±15V, R<sub>L</sub>=2kΩ)

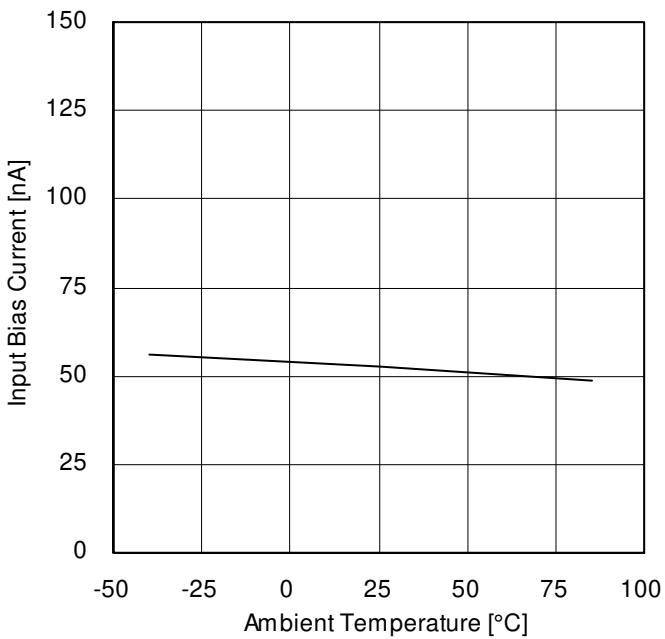

Figure 16.  
Input Bias Current vs Ambient Temperature  
(VCC/VEE=±15V)

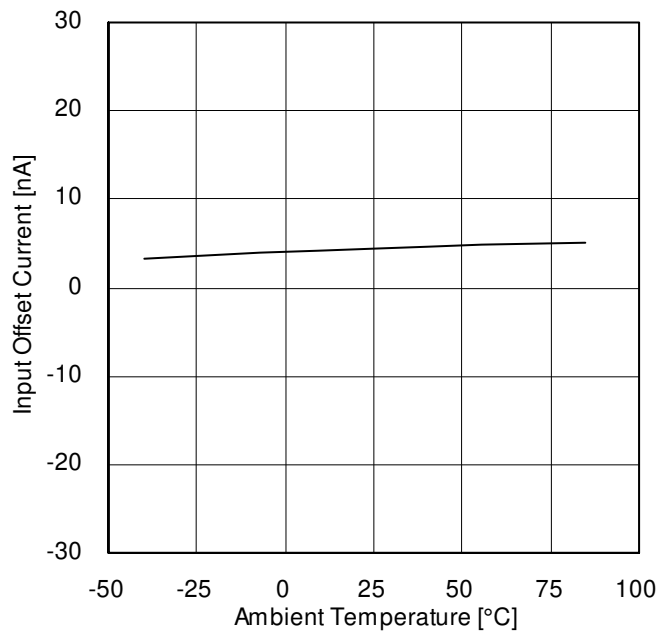

Figure 17.  
Input Offset Current vs Ambient Temperature  
(VCC/VEE=±15V)

(\*The data above is measurement value of typical sample, it is not guaranteed.

Typical Performance Curves (Reference data) - continued  
 OLM4559xxx

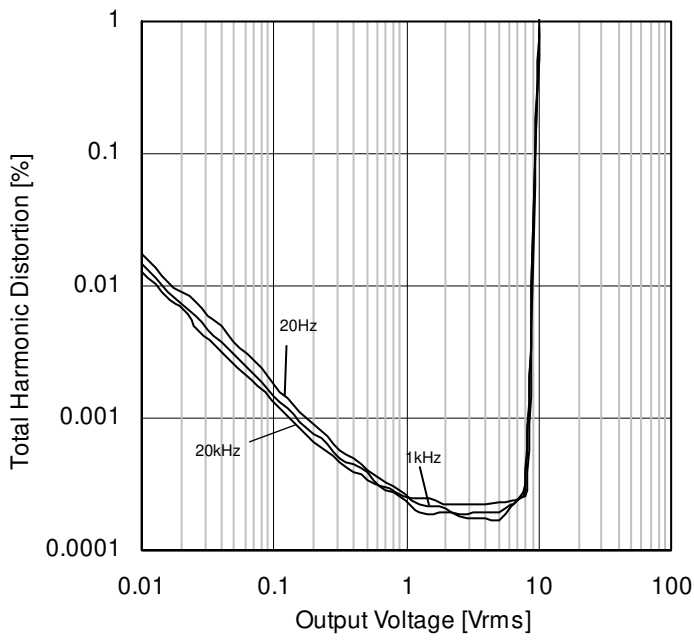

Figure 18.  
 Total Harmonic Distortion vs Output Voltage  
 (VCC/VEE=±15V, RL=2kΩ)

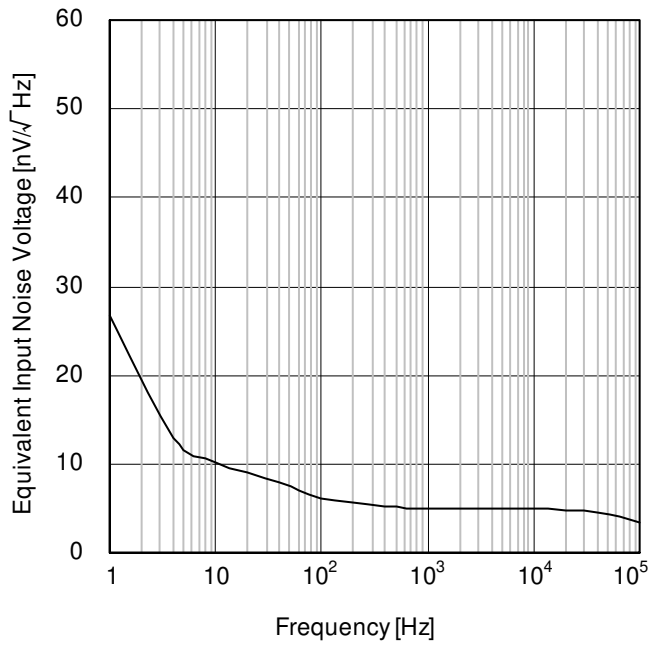

Figure 19.  
 Equivalent Input Noise Voltage vs Frequency  
 (VCC/VEE=±15V, TA=25°C, AV=40dB)

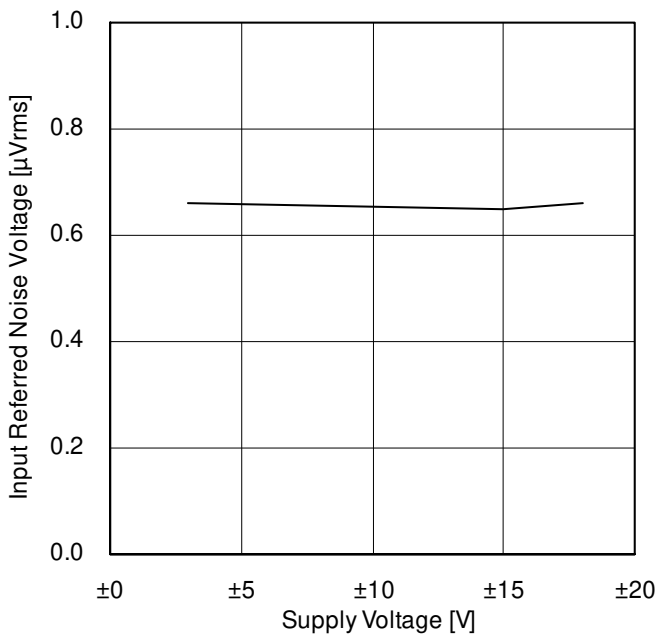

Figure 20.  
 Equivalent Input Noise Voltage vs Supply Voltage  
 (TA=25°C, DIN AUDIO)

(\*)The data above is measurement value of typical sample, it is not guaranteed.

**Application Information**  
**NULL method condition for Test Circuit 1**

Parameter	V <sub>F</sub>	S1	S2	S3	VCC, VEE, E <sub>K</sub> , V <sub>ICM</sub> Unit:V				Calculation
					VCC	VEE	E <sub>K</sub>	V <sub>ICM</sub>	
Input Offset Voltage	V <sub>F1</sub>	ON	ON	OFF	15	-15	0	0	1
Large Signal Voltage Gain	V <sub>F2</sub>	ON	ON	ON	15	-15	-10	0	2
	V <sub>F3</sub>						10		
Common Mode Rejection Ratio (Input Common-mode Voltage Range)	V <sub>F4</sub>	ON	ON	OFF	15	-15	0	-10	3
	V <sub>F5</sub>						0	10	
Power Supply Rejection Ratio	V <sub>F6</sub>	ON	ON	OFF	4	-4	0	0	4
	V <sub>F7</sub>				18	-18			

— Calculation —

- Input Offset Voltage (V<sub>IO</sub>) 
$$V_{IO} = \frac{|V_{F1}|}{1+R_F/R_S} [V]$$
- Large Signal Voltage Gain (A<sub>V</sub>) 
$$A_V = 20\text{Log} \frac{\Delta E_K \times (1+R_F/R_S)}{|V_{F2}-V_{F3}|} [dB]$$
- Common Mode Rejection Ratio (CMRR) 
$$\text{CMRR} = 20\text{Log} \frac{\Delta V_{ICM} \times (1+R_F/R_S)}{|V_{F4} - V_{F5}|} [dB]$$
- Power Supply Rejection Ratio (PSRR) 
$$\text{PSRR} = 20\text{Log} \frac{\Delta V_{CC} \times (1+R_F/R_S)}{|V_{F6} - V_{F7}|} [dB]$$

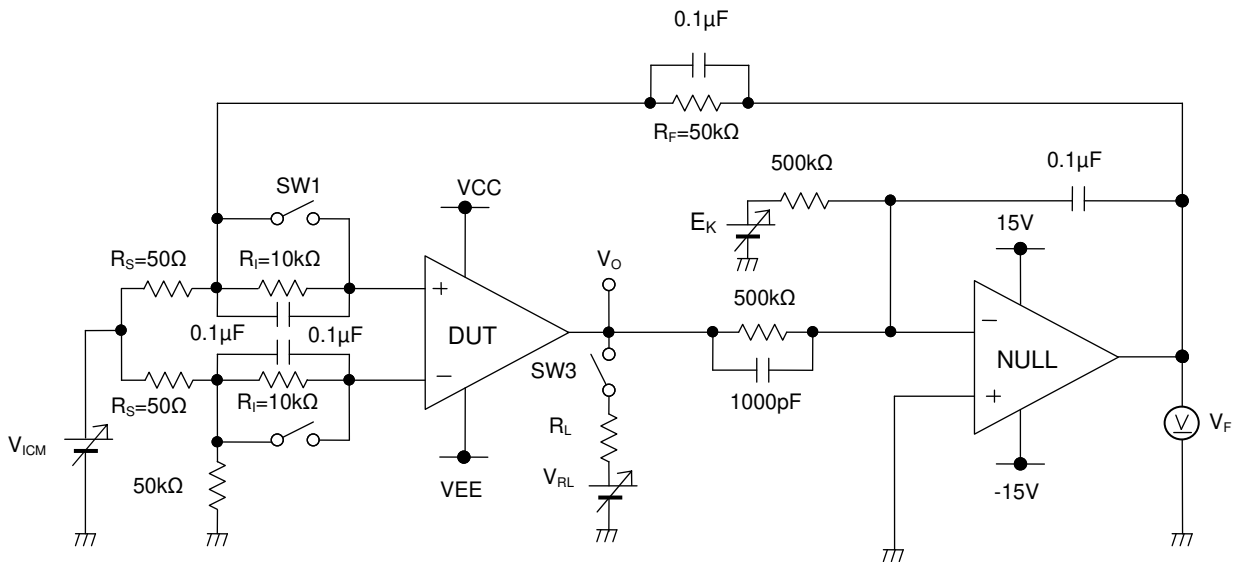

Figure 21. Test Circuit 1

Switch Condition for Test Circuit 2

SW No.	SW1	SW2	SW3	SW4	SW5	SW6	SW7	SW8	SW9	SW10	SW11	SW12
Supply Current	OFF	OFF	ON	OFF	ON	OFF	OFF	OFF	OFF	OFF	OFF	OFF
Maximum Output Voltage $R_L=2k\Omega$	OFF	ON	OFF	OFF	ON	OFF	OFF	ON	OFF	OFF	ON	OFF
Slew Rate	OFF	OFF	ON	OFF	OFF	OFF	ON	OFF	ON	OFF	OFF	ON
Unity Gain Frequency	ON	OFF	OFF	ON	ON	OFF	OFF	OFF	ON	OFF	OFF	ON

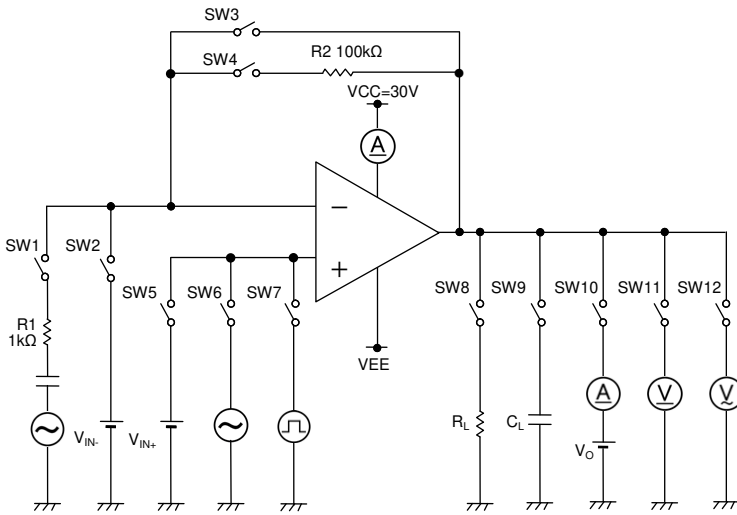

Figure 22. Test Circuit2

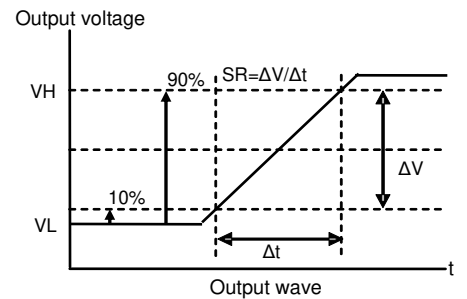
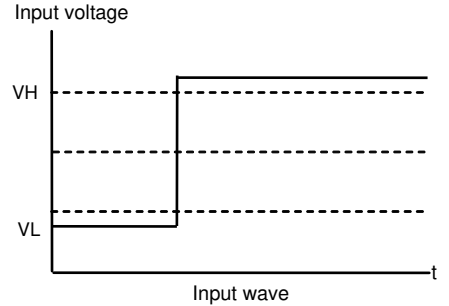

Figure 23. Slew Rate Input Output Wave

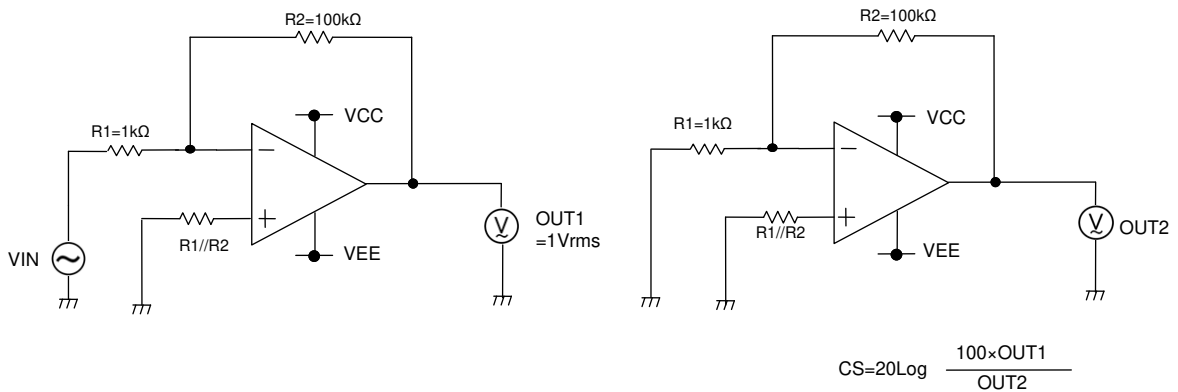

Figure 24. Test Circuit 3 (Channel Separation)

**Application Example**

○Voltage follower

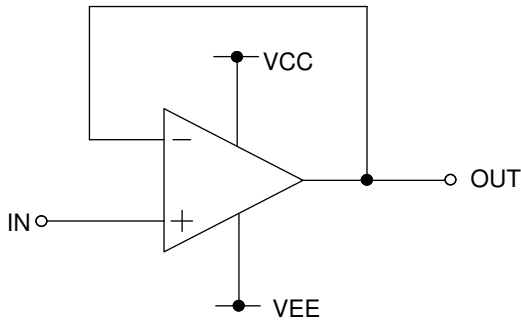

Figure 25. Voltage Follower

Voltage gain is 0dB.

Using this circuit, the output voltage (OUT) is controlled to be equal to the input voltage (IN). This circuit also stabilizes OUT due to high input impedance and low output impedance. Computation for OUT is shown below.

$$OUT=IN$$

○Inverting amplifier

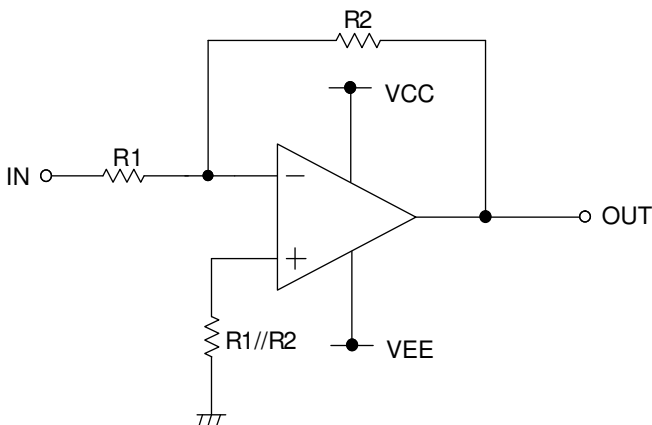

Figure 26. Inverting Amplifier Circuit

For inverting amplifier, IN is amplified by a voltage gain decided by the ratio of R1 and R2. The out-of-phase output voltage is shown in the next expression.

$$OUT=-(R2/R1) \cdot IN$$

This circuit has input impedance equal to R1.

○Non-inverting amplifier

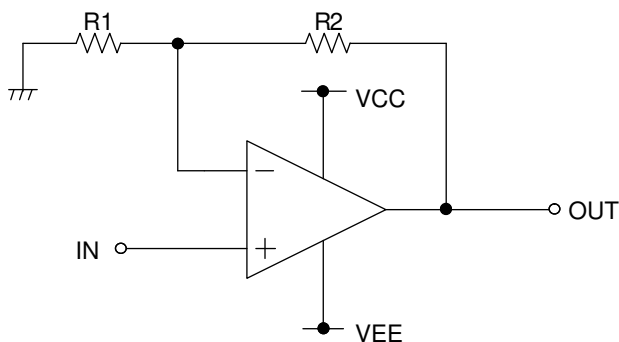

Figure 27. Non-inverting Amplifier Circuit

For non-inverting amplifier, IN is amplified by a voltage gain decided by the ratio of R1 and R2. OUT is in-phase with IN and is shown in the next expression.

$$OUT=(1+R2/R1) \cdot IN$$

Effectively, this circuit has high input impedance since its input side is the same as that of the operational amplifier.

**Power Dissipation**

Power dissipation (total loss) indicates the power that the IC can consume at  $T_A=25^\circ\text{C}$  (normal temperature). As the IC consumes power, it heats up, causing its temperature to be higher than the ambient temperature. The allowable temperature that the IC can accept is limited. This depends on the circuit configuration, manufacturing process, and consumable power.

Power dissipation is determined by the allowable temperature within the IC (maximum junction temperature) and the thermal resistance of the package used (heat dissipation capability). Maximum junction temperature is typically equal to the maximum storage temperature. The heat generated through the consumption of power by the IC radiates from the mold resin or lead frame of the package. Thermal resistance, represented by the symbol  $\theta_{JA}^\circ\text{C/W}$ , indicates this heat dissipation capability. Similarly, the temperature of an IC inside its package can be estimated by thermal resistance.

Figure 28 (a) shows the model of the thermal resistance of a package. The equation below shows how to compute for the Thermal resistance ( $\theta_{JA}$ ), given the ambient temperature ( $T_A$ ), maximum junction temperature ( $T_{Jmax}$ ), and power dissipation ( $P_D$ ).

$$\theta_{JA} = (T_{Jmax} - T_A) / P_D \quad ^\circ\text{C/W} \quad \dots \dots \dots (I)$$

The derating curve in Figure 28 (b) indicates the power that the IC can consume with reference to ambient temperature. Power consumption of the IC begins to attenuate at certain temperatures. This gradient is determined by Thermal resistance ( $\theta_{JA}$ ), which depends on the chip size, power consumption, package, ambient temperature, package condition, wind velocity, etc. This may also vary even when the same of package is used. Thermal reduction curve indicates a reference value measured at a specified condition. Figure 28 (c) shows an example of the derating curve for LM4559xxx.

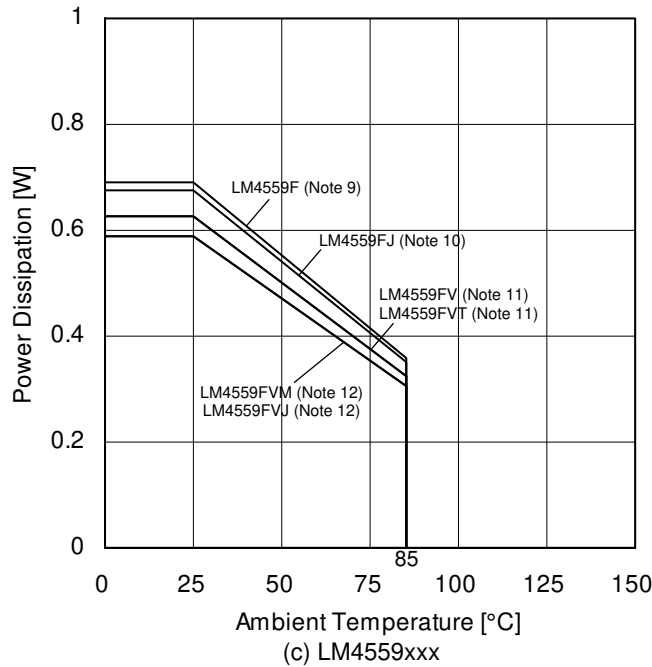
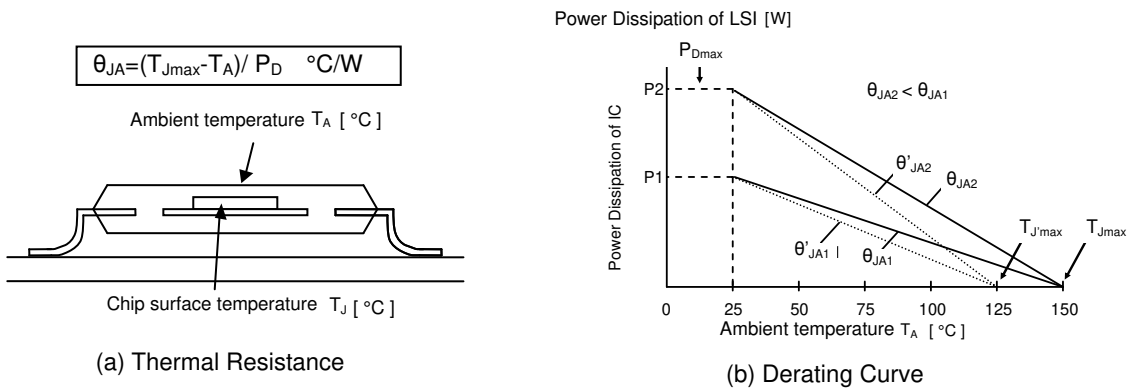

(9)	(10)	(11)	(12)	Unit
5.5	5.4	5.0	4.7	mW/°C

When using the unit above  $T_A=25^\circ\text{C}$ , subtract the value above per  $^\circ\text{C}$ . Permissible dissipation is the value when FR4 glass epoxy board  $70\text{mm} \times 70\text{mm} \times 1.6\text{mm}$  (copper foil area below 3%) is mounted

Figure 28. Thermal Resistance and Derating Curve

**Operational Notes****1. Reverse Connection of Power Supply**

Connecting the power supply in reverse polarity can damage the IC. Take precautions against reverse polarity when connecting the power supply, such as mounting an external diode between the power supply and the IC's power supply pins.

**2. Power Supply Lines**

Design the PCB layout pattern to provide low impedance supply lines. Separate the ground and supply lines of the digital and analog blocks to prevent noise in the ground and supply lines of the digital block from affecting the analog block. Furthermore, connect a capacitor to ground at all power supply pins. Consider the effect of temperature and aging on the capacitance value when using electrolytic capacitors.

**3. Ground Voltage**

Ensure that no pins are at a voltage below that of the ground pin at any time, even during transient condition.

**4. Ground Wiring Pattern**

When using both small-signal and large-current ground traces, the two ground traces should be routed separately but connected to a single ground at the reference point of the application board to avoid fluctuations in the small-signal ground caused by large currents. Also ensure that the ground traces of external components do not cause variations on the ground voltage. The ground lines must be as short and thick as possible to reduce line impedance.

**5. Thermal Consideration**

Should by any chance the power dissipation rating be exceeded the rise in temperature of the chip may result in deterioration of the properties of the chip. The absolute maximum rating of the  $P_D$  stated in this specification is when the IC is mounted on a 70mm x 70mm x 1.6mm glass epoxy board. In case of exceeding this absolute maximum rating, increase the board size and copper area to prevent exceeding the  $P_D$  rating.

**6. Recommended Operating Conditions**

These conditions represent a range within which the expected characteristics of the IC can be approximately obtained. The electrical characteristics are guaranteed under the conditions of each parameter.

**7. Inrush Current**

When power is first supplied to the IC, it is possible that the internal logic may be unstable and inrush current may flow instantaneously due to the internal powering sequence and delays, especially if the IC has more than one power supply. Therefore, give special consideration to power coupling capacitance, power wiring, width of ground wiring, and routing of connections.

**8. Operation Under Strong Electromagnetic Field**

Operating the IC in the presence of a strong electromagnetic field may cause the IC to malfunction.

**9. Testing on Application Boards**

When testing the IC on an application board, connecting a capacitor directly to a low-impedance output pin may subject the IC to stress. Always discharge capacitors completely after each process or step. The IC's power supply should always be turned off completely before connecting or removing it from the test setup during the inspection process. To prevent damage from static discharge, ground the IC during assembly and use similar precautions during transport and storage.

**10. Inter-pin Short and Mounting Errors**

Ensure that the direction and position are correct when mounting the IC on the PCB. Incorrect mounting may result in damaging the IC. Avoid nearby pins being shorted to each other especially to ground, power supply and output pin. Inter-pin shorts could be due to many reasons such as metal particles, water droplets (in very humid environment) and unintentional solder bridge deposited in between pins during assembly to name a few.

## Operational Notes – continued

**11. Regarding the Input Pin of the IC**

This monolithic IC contains P+ isolation and P substrate layers between adjacent elements in order to keep them isolated. P-N junctions are formed at the intersection of the P layers with the N layers of other elements, creating a parasitic diode or transistor. For example (refer to figure below):

When  $GND > Pin A$  and  $GND > Pin B$ , the P-N junction operates as a parasitic diode.

When  $GND > Pin B$ , the P-N junction operates as a parasitic transistor.

Parasitic diodes inevitably occur in the structure of the IC. The operation of parasitic diodes can result in mutual interference among circuits, operational faults, or physical damage. Therefore, conditions that cause these diodes to operate, such as applying a voltage lower than the GND voltage to an input pin (and thus to the P substrate) should be avoided.

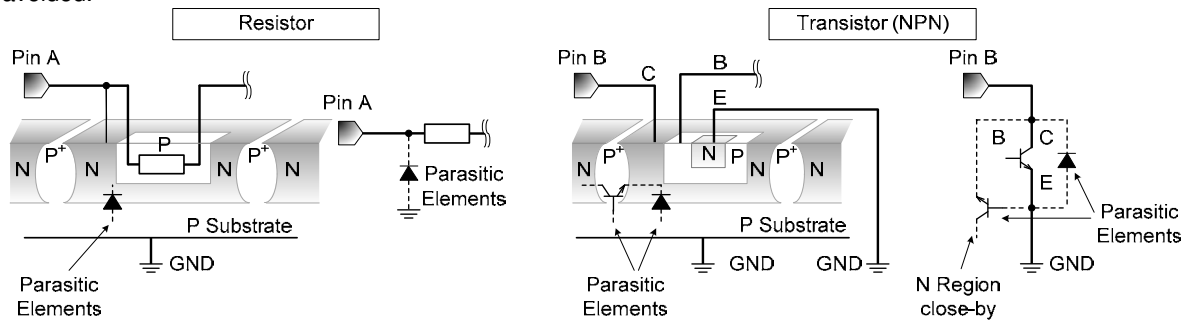

Figure 30. Example of monolithic IC structure

**12. Unused Circuits**

It is recommended to apply the connection (see Figure 29.) and set the non-inverting input terminal at a potential within the Input Common-mode Voltage Range ( $V_{ICM}$ ) for any unused circuit.

**13. Input Voltage**

Applying  $VEE + 36V$  to the input terminal is possible without causing deterioration of the electrical characteristics or destruction, regardless of the supply voltage. However, this does not ensure normal circuit operation. Please note that the circuit operates normally only when the input voltage is within the common mode input voltage range of the electric characteristics.

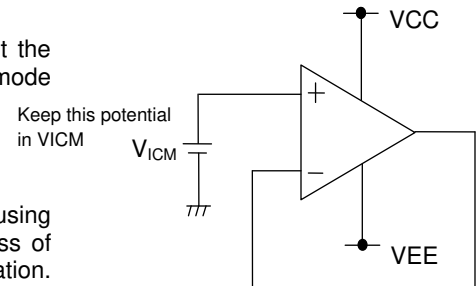

Figure 31. The Example of Application Circuit for Unused Op-amp

**14. Power Supply(single/dual)**

The voltage comparator operates if a certain level of voltage is applied between VCC and VEE. Therefore, the operational amplifier can be operated under single power supply or split power supply.

**15. IC Handling**

When pressure is applied to the IC through warp on the printed circuit board, the characteristics may fluctuate due to the piezo effect. Be careful with the warp on the printed circuit board.

**16. The IC Destruction Caused by Capacitive Load**

The IC may be damaged when VCC terminal and VEE terminal is shorted with the charged output terminal capacitor. When IC is used as an operational amplifier or as an application circuit where oscillation is not activated by an output capacitor, output capacitor must be kept below  $0.1\mu F$  in order to prevent the damage mentioned above.

Physical Dimensions Tape and Reel Information

Package Name	SOP8
--------------	------

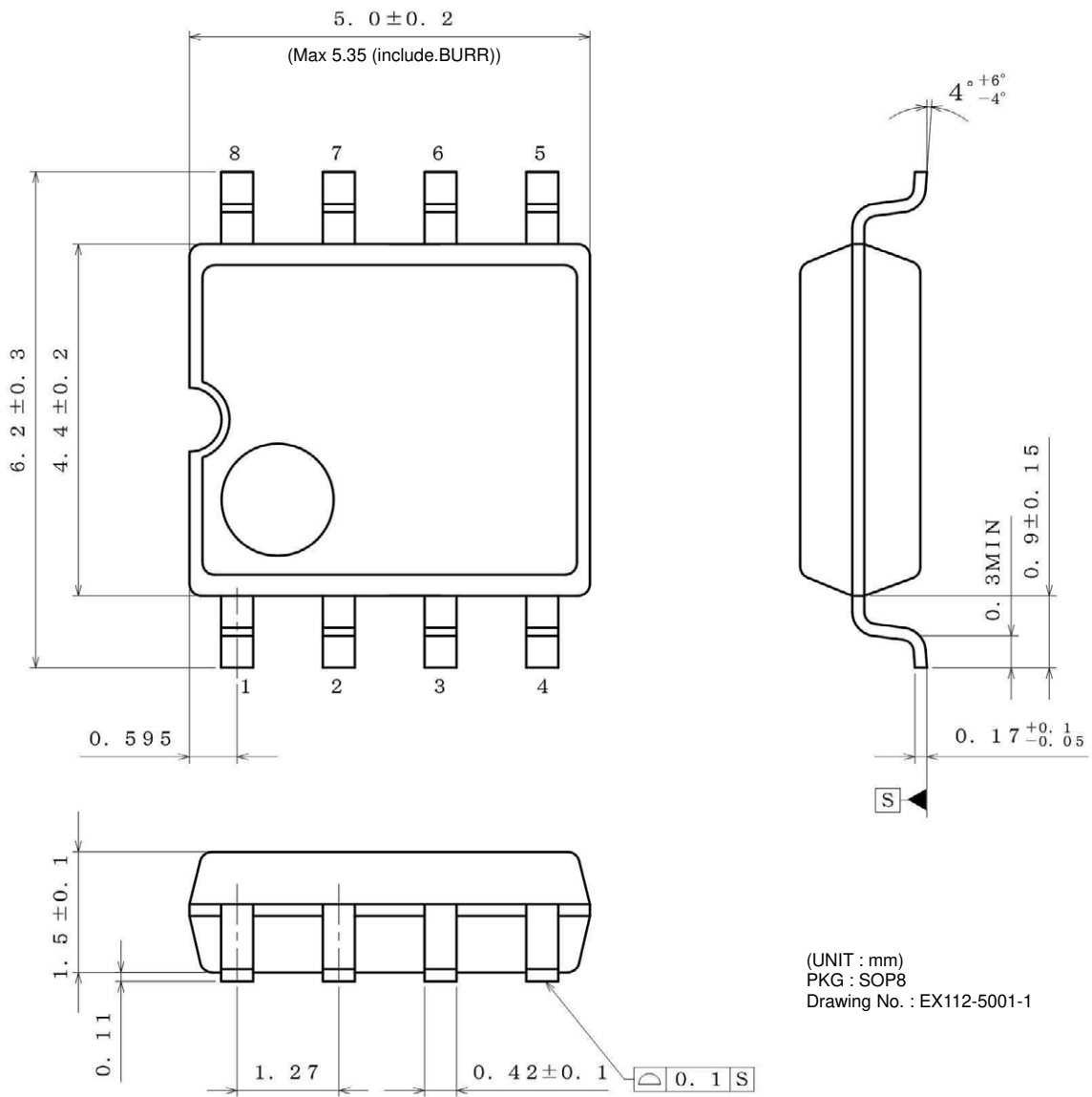

(UNIT : mm)  
 PKG : SOP8  
 Drawing No. : EX112-5001-1

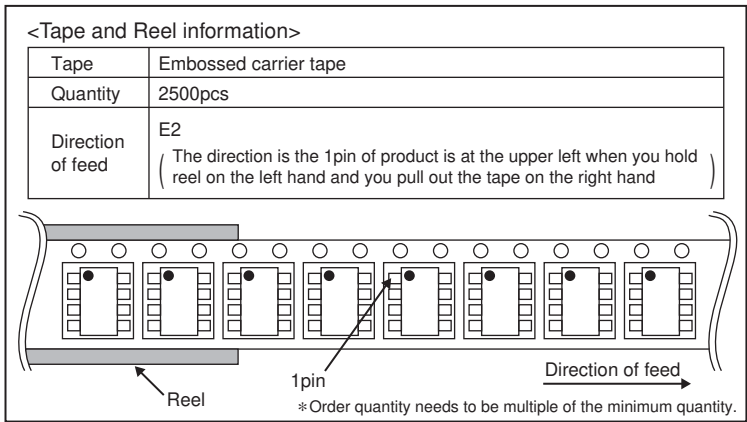

Physical Dimension Tape and Reel Information - continued

Package Name	SOP-J8
--------------	--------

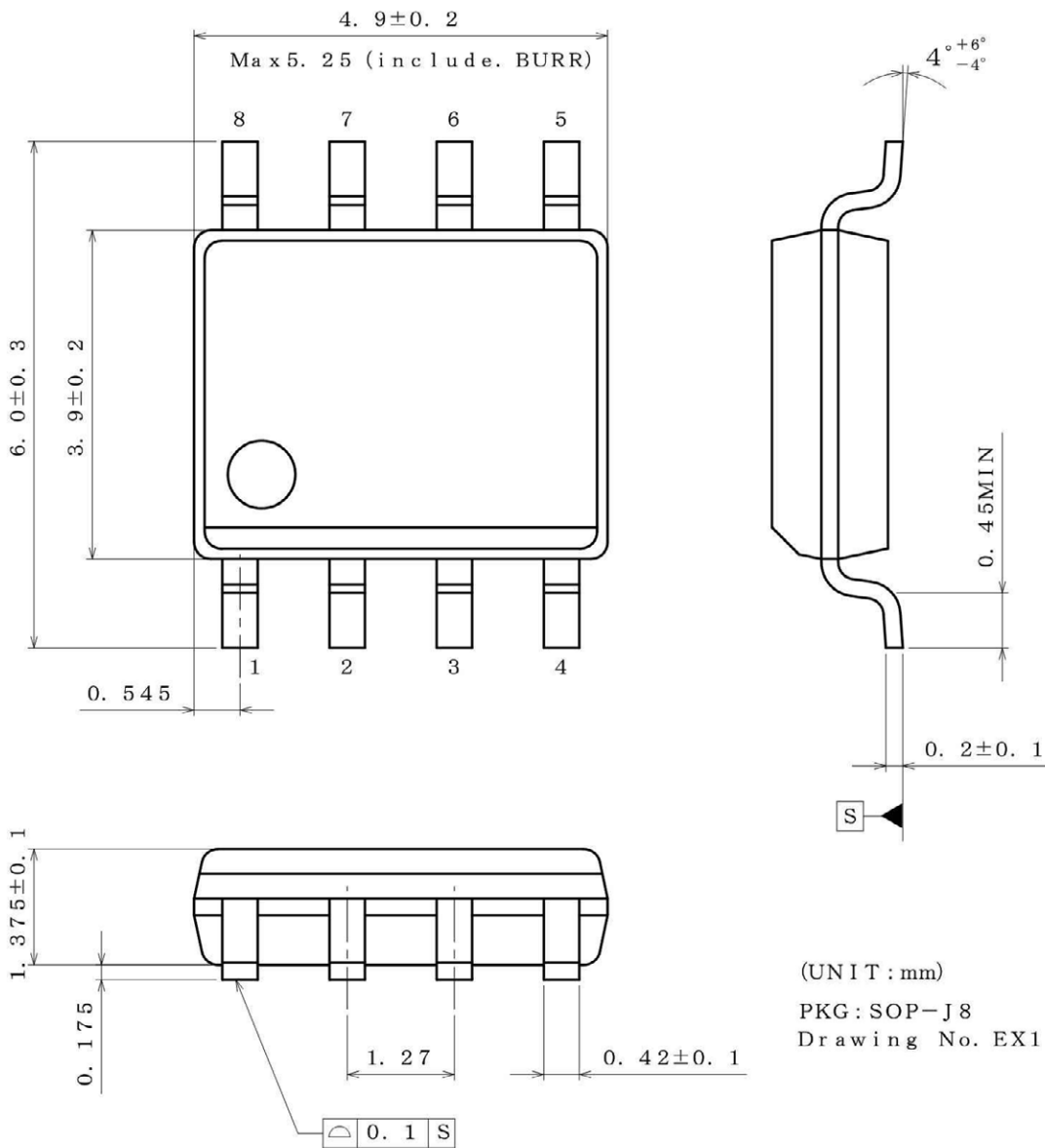

(UNIT : mm)  
 PKG : SOP-J8  
 Drawing No. EX111-5002

<Tape and Reel information>

Tape	Embossed carrier tape
Quantity	2500pcs
Direction of feed	E2 (The direction is the 1pin of product is at the upper left when you hold reel on the left hand and you pull out the tape on the right hand)

1pin  
 \*Order quantity needs to be multiple of the minimum quantity.

Physical Dimension Tape and Reel Information - continued

Package Name	SSOP-B8
--------------	---------

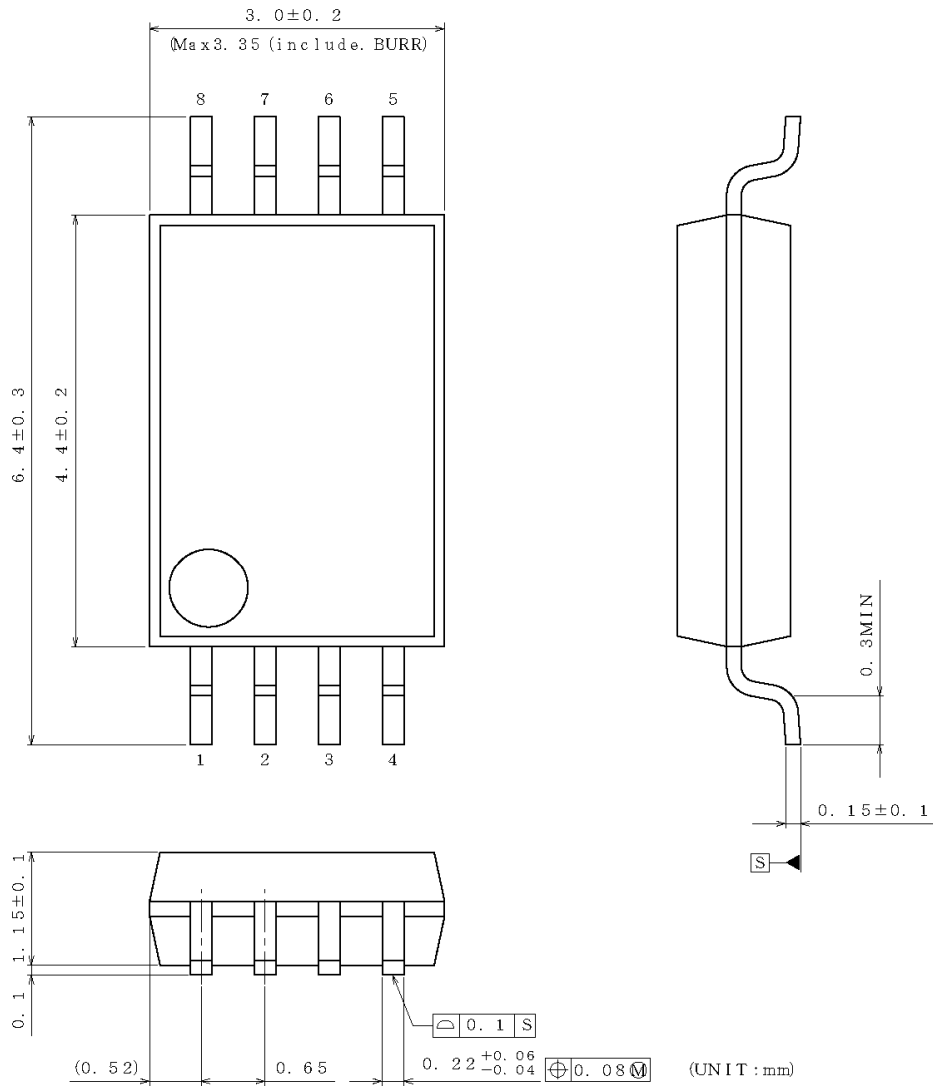

(UNIT : mm)  
 PKG : SSOP-B8  
 Drawing No. EX151-5002

<Tape and Reel information>

Tape	Embossed carrier tape
Quantity	2500pcs
Direction of feed	E2 ( The direction is the 1pin of product is at the upper left when you hold reel on the left hand and you pull out the tape on the right hand )

Reel

1pin

Direction of feed

\* Order quantity needs to be multiple of the minimum quantity.

Physical Dimension Tape and Reel Information - continued

Package Name	TSSOP-B8
--------------	----------

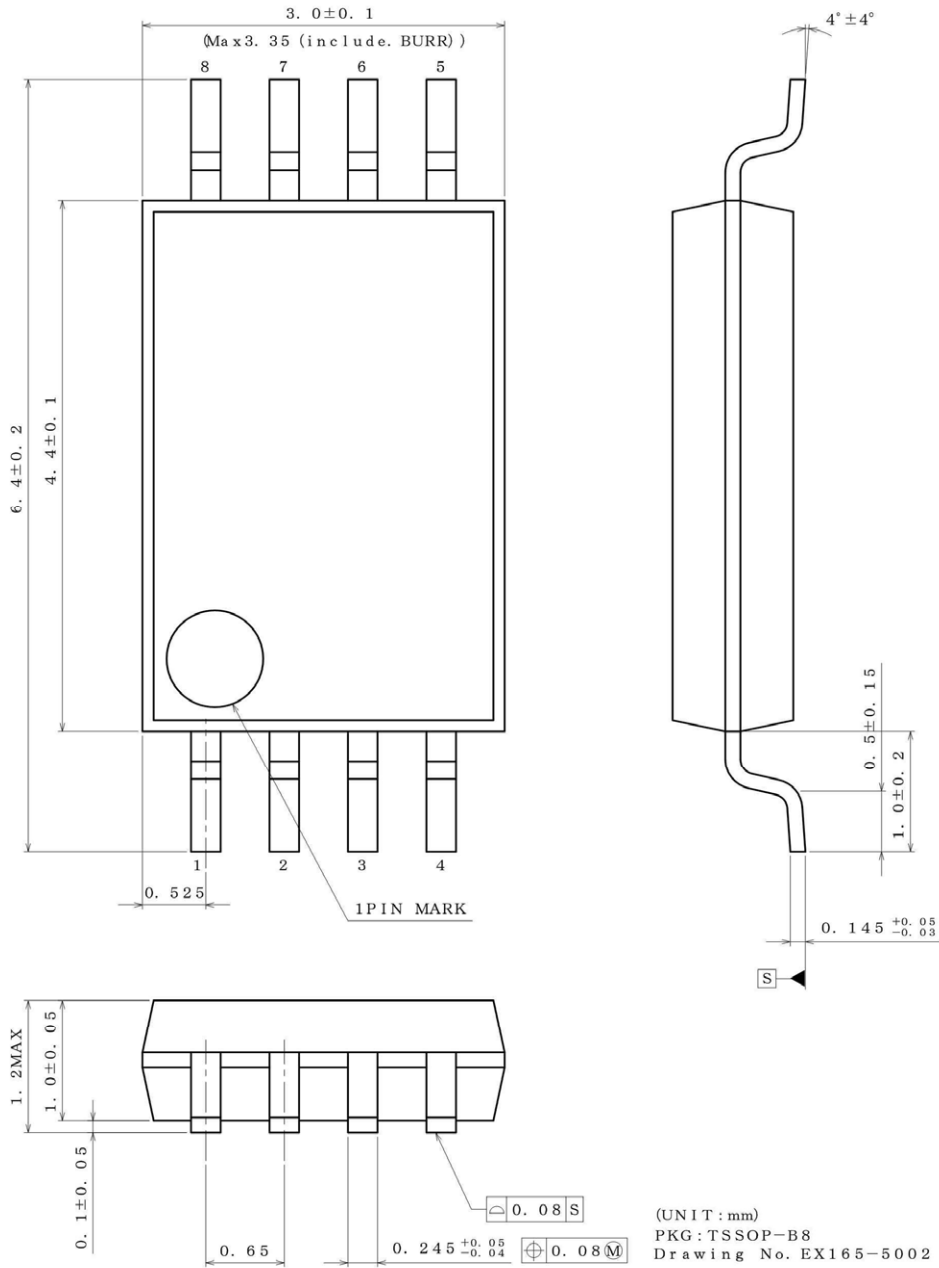

<Tape and Reel information>

Tape	Embossed carrier tape
Quantity	3000pcs
Direction of feed	E2 ( The direction is the 1pin of product is at the upper left when you hold reel on the left hand and you pull out the tape on the right hand )

Reel 1 pin Direction of feed

\* Order quantity needs to be multiple of the minimum quantity.

Physical Dimension Tape and Reel Information - continued

Package Name	MSOP8
--------------	-------

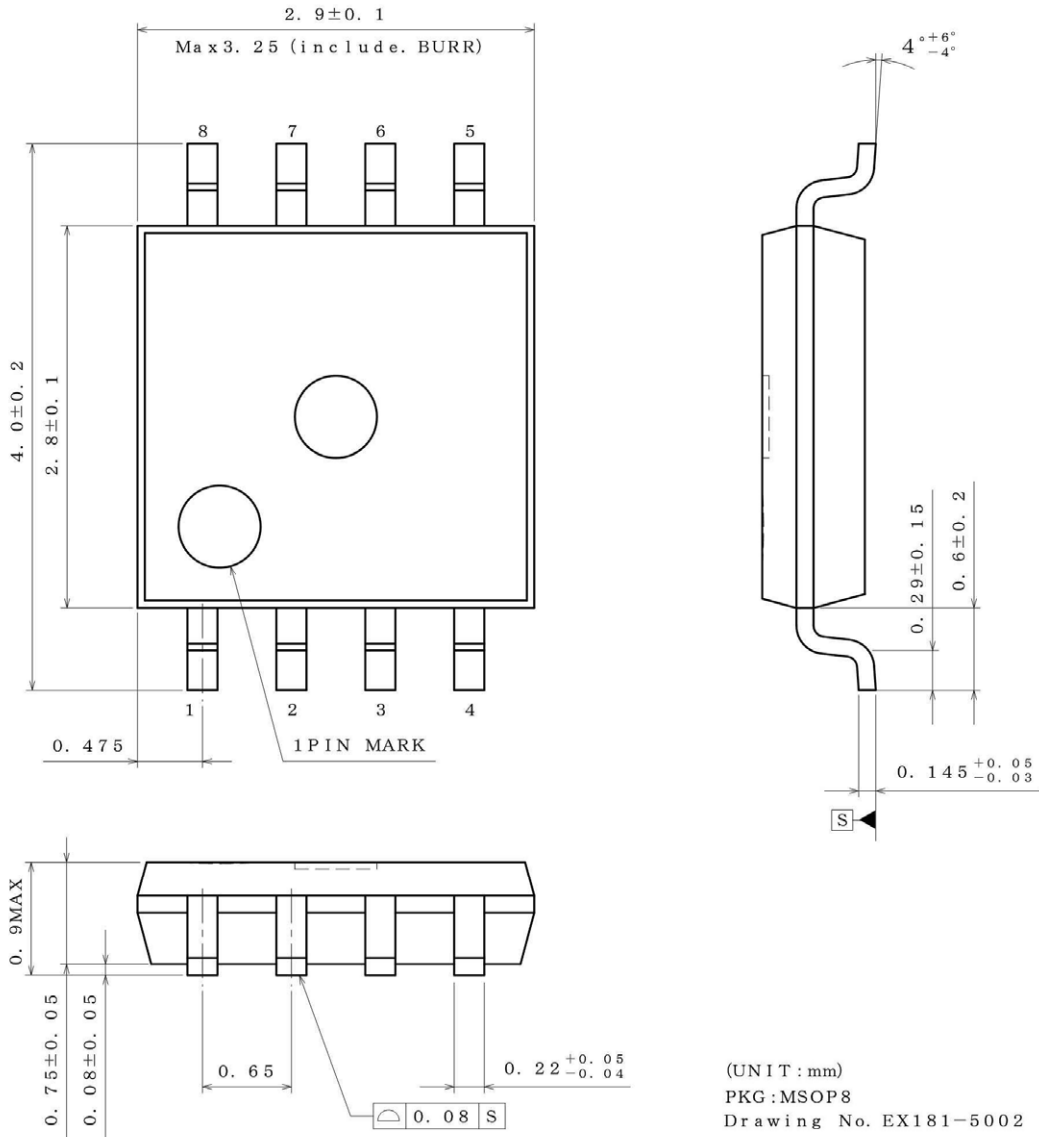

<Tape and Reel information>

Tape	Embossed carrier tape
Quantity	3000pcs
Direction of feed	TR (The direction is the 1pin of product is at the upper right when you hold reel on the left hand and you pull out the tape on the right hand)

\* Order quantity needs to be multiple of the minimum quantity.

Physical Dimension Tape and Reel Information - continued

Package Name	TSSOP-B8J
--------------	-----------

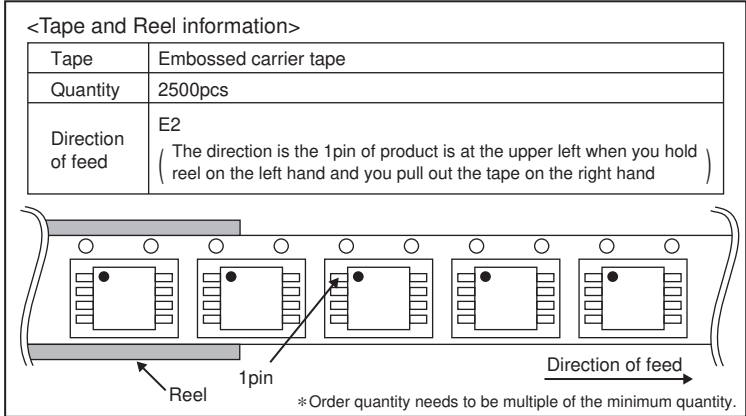
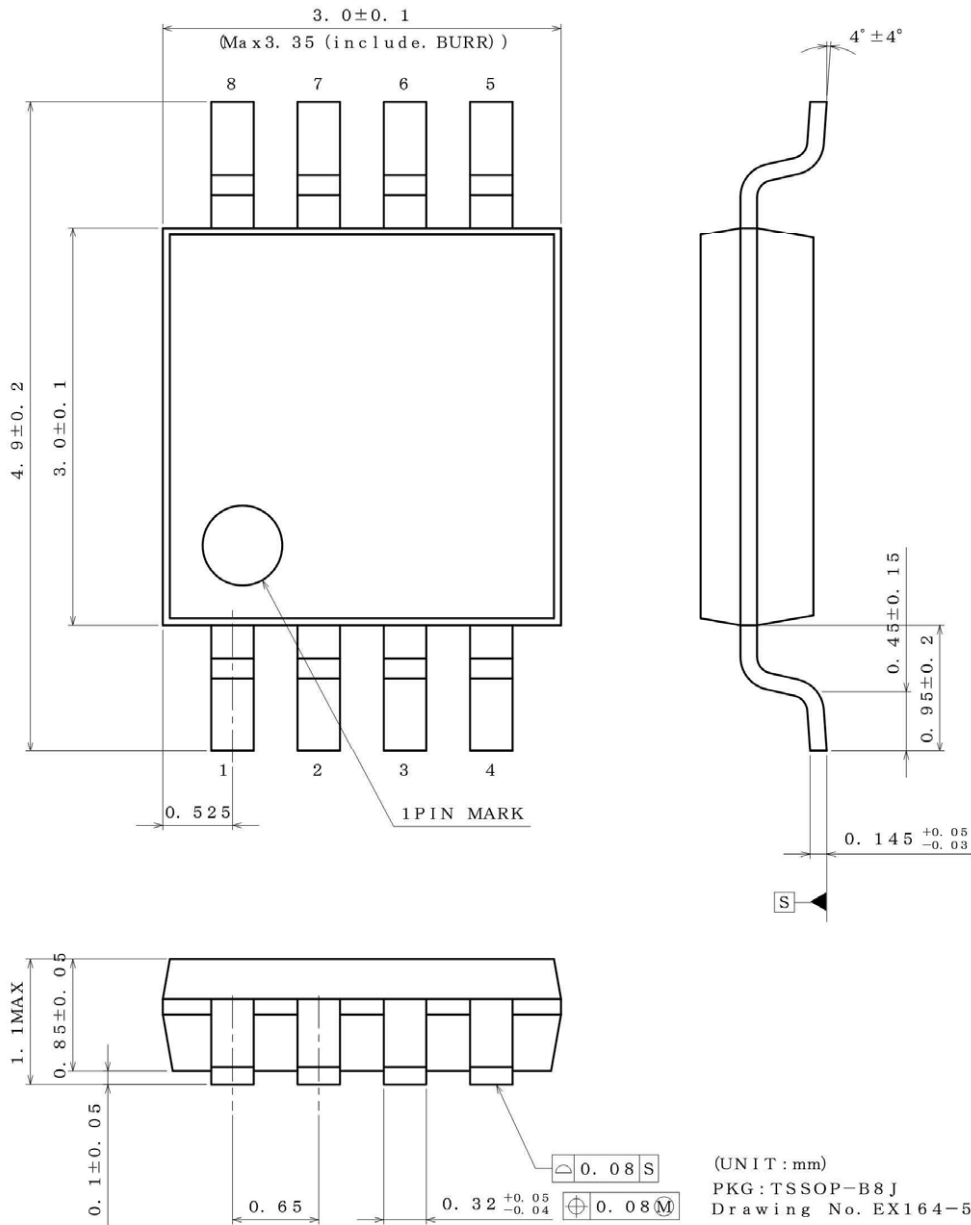

Marking Diagram

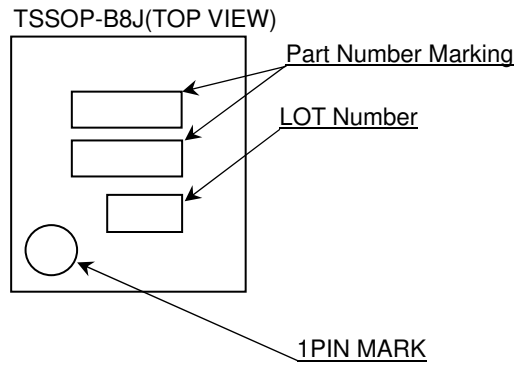
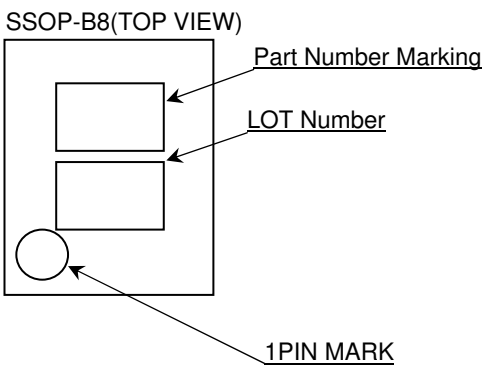
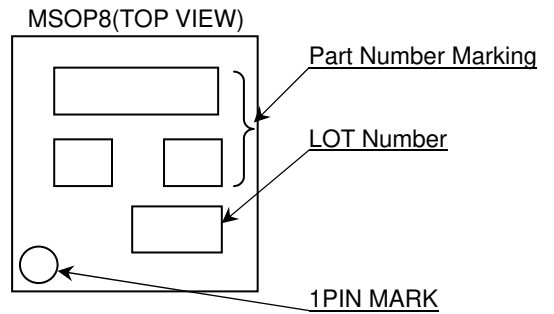
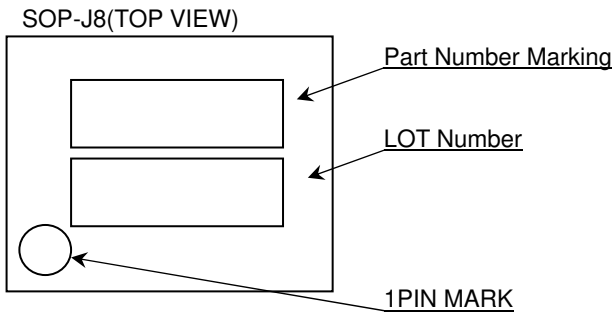
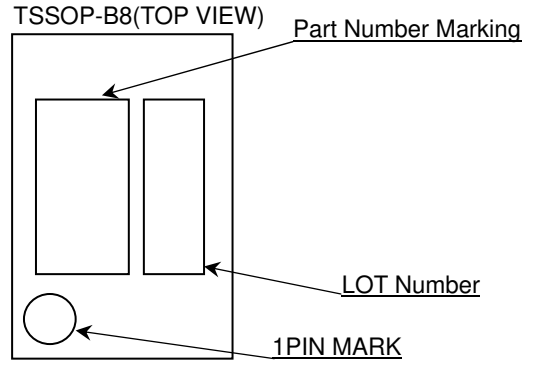
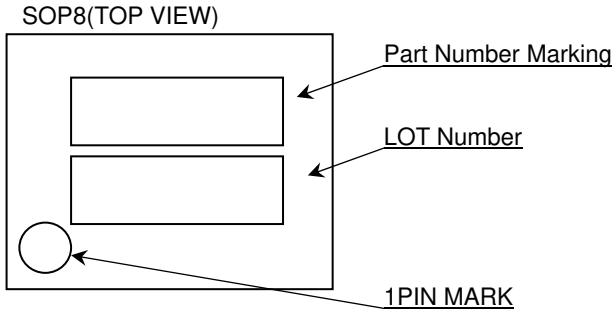

Product Name		Package Type	Marking
LM4559	F	SOP8	4559
	FJ	SOP-J8	L4559
	FV	SSOP-B8	4559
	FVT	TSSOP-B8	L4559
	FVM	MSOP8	L4559
	FVJ	TSSOP-B8J	L4559

Land Pattern Data

All dimensions in mm

PKG	Land pitch e	Land space MIE	Land length ≥l 2	Land width b2
SOP8	1.27	4.60	1.10	0.76
SOP-J8	1.27	3.90	1.35	0.76
SSOP-B8	0.65	4.60	1.20	0.35
TSSOP-B8	0.65	4.60	1.20	0.35
MSOP8	0.65	2.62	0.99	0.35
TSSOP-B8J	0.65	3.20	1.15	0.35

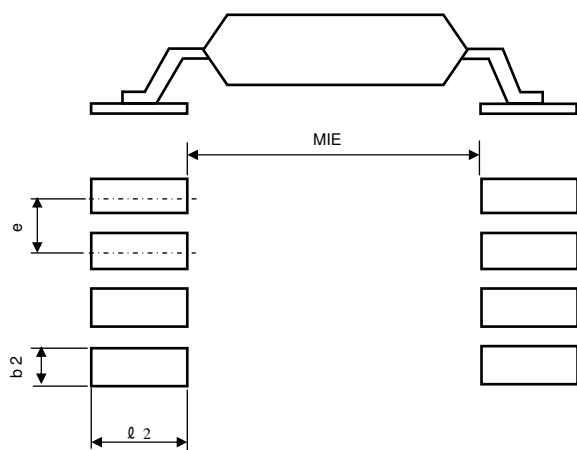

Revision History

Date	Revision	Changes
30.Nov.2012	001	New Release
28.Aug.2013	002	Added LM4559FV, LM4559FJ,LM4559FVT,LM4559FVM,LM4559FVJ
04.Dec.2013	003	Changed Input Bias Current(Max value)