



Chipsmall Limited consists of a professional team with an average of over 10 year of expertise in the distribution of electronic components. Based in Hongkong, we have already established firm and mutual-benefit business relationships with customers from,Europe,America and south Asia,supplying obsolete and hard-to-find components to meet their specific needs.

With the principle of "Quality Parts,Customers Priority,Honest Operation,and Considerate Service",our business mainly focus on the distribution of electronic components. Line cards we deal with include Microchip,ALPS,ROHM,Xilinx,Pulse,ON,Everlight and Freescale. Main products comprise IC,Modules,Potentiometer,IC Socket,Relay,Connector.Our parts cover such applications as commercial,industrial, and automotives areas.

We are looking forward to setting up business relationship with you and hope to provide you with the best service and solution. Let us make a better world for our industry!



Contact us

Tel: +86-755-8981 8866 Fax: +86-755-8427 6832

Email & Skype: info@chipsmall.com Web: www.chipsmall.com

Address: A1208, Overseas Decoration Building, #122 Zhenhua RD., Futian, Shenzhen, China



200 mA LOAD SWITCH FEATURING PRE-BIASED PNP TRANSISTOR AND N-MOSFET WITH GATE PULL DOWN RESISTOR

General Description

LMN200B02 is best suited for applications where the load needs to be turned on and off using control circuits like micro-controllers, comparators etc. particularly at a point of load. It features a discrete pass transistor with stable $V_{CE(SAT)}$ which does not depend on the input voltage and can support continuous maximum current of 200 mA. It also contains a discrete N-MOSFET that can be used as control. This N-MOSFET also has a built-in pull down resistor at its gate. The component can be used as a part of a circuit or as a stand alone discrete device.

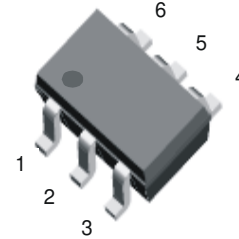

Fig. 1: SOT-363

Features

- Voltage Controlled Small Signal Switch
- N-MOSFET with Gate Pull-Down Resistor
- Surface Mount Package
- Ideally Suited for Automated Assembly Processes
- **Lead Free By Design/RoHS Compliant (Note 1)**
- **"Green" Device (Note 2)**

Mechanical Data

- Case: SOT-363
- Case Material: Molded Plastic, "Green" Molding Compound. UL Flammability Classification Rating 94V-0
- Moisture Sensitivity: Level 1 per J-STD-020
- Terminal Connections: See Diagram
- Terminals: Finish - Matte Tin annealed over Alloy 42 leadframe. Solderable per MIL-STD-202, Method 208
- Marking Information: See Page 8
- Ordering Information: See Page 8
- Weight: 0.006 grams (approximate)

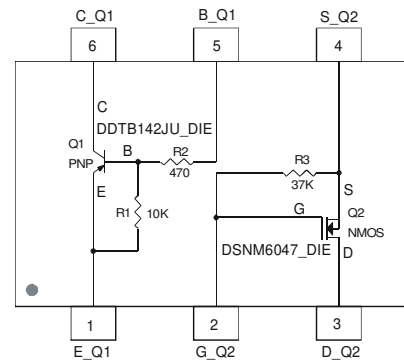

Fig. 2 Schematic and Pin Configuration

Sub-Component P/N	Reference	Device Type	R1 (NOM)	R2 (NOM)	R3 (NOM)	Figure
DDTB142JU_DIE	Q1	PNP Transistor	10K	470	—	2
DSNM6047_DIE (with Gate Pull-Down Resistor)	Q2	N-MOSFET	—	—	37K	2

Maximum Ratings, Total Device @ $T_A = 25^\circ\text{C}$ unless otherwise specified

Characteristic	Symbol	Value	Unit
Power Dissipation (Note 3)	P_D	200	mW
Power Derating Factor above 125°C	P_{der}	1.6	mW/ $^\circ\text{C}$
Output Current	I_{out}	200	mA

Thermal Characteristics @ $T_A = 25^\circ\text{C}$ unless otherwise specified

Characteristic	Symbol	Value	Unit
Operating and Storage Temperature Range	T_J, T_{STG}	-55 to +150	$^\circ\text{C}$
Thermal Resistance, Junction to Ambient Air (Equivalent to One Heated Junction of PNP Transistor) (Note 3)	$R_{\theta JA}$	625	$^\circ\text{C}/\text{W}$

- Notes:
1. No purposefully added lead.
 2. Diodes Inc.'s "Green" policy can be found on our website at http://www.diodes.com/products/lead_free/index.php.
 3. Device mounted on FR-4 PCB, 1 inch x 0.85 inch x 0.062 inch; pad layout as shown on Diodes Inc. suggested pad layout document AP02001, which can be found on our website at <http://www.diodes.com/datasheets/ap02001.pdf>.

Maximum Ratings:

Sub-Component Device: Pre-Biased PNP Transistor (Q1) @T_A = 25°C unless otherwise specified

Characteristic	Symbol	Value	Unit
Collector-Base Voltage	V _{CBO}	-50	V
Collector-Emitter Voltage	V _{CEO}	-50	V
Supply Voltage	V _{CC}	-50	V
Input Voltage	V _{in}	+5 to -6	V
Output Current	I _C	-200	mA

Sub-Component Device: N-MOSFET With Gate Pull-Down Resistor (Q2)

@T_A = 25°C unless otherwise specified

Characteristic	Symbol	Value	Unit
Drain-Source Voltage	V _{DSS}	60	V
Drain Gate Voltage (R _{GS} ≤ 1M Ohm)	V _{DGR}	60	V
Gate-Source Voltage	V _{GSS}	Continuous	V
		Pulsed (tp < 50 uS)	
Drain Current (Page 1: Note 3)	I _D	Continuous (V _{gs} = 10V)	mA
		Pulsed (tp < 10 uS, Duty Cycle < 1%)	
Continuous Source Current	I _S	115	mA

Electrical Characteristics: Pre-Biased PNP Transistor (Q1)

 @T_A = 25°C unless otherwise specified

Characteristic	Symbol	Min	Typ	Max	Unit	Test Condition
OFF CHARACTERISTICS						
Collector-Base Cut Off Current	I _{CB0}	—	—	-100	nA	V _{CB} = -50V, I _E = 0
Collector-Emitter Cut Off Current	I _{CEO}	—	—	-500	nA	V _{CE} = -50V, I _B = 0
Emitter-Base Cut Off Current	I _{EBO}	—	-0.5	-1	mA	V _{EB} = -5V, I _C = 0
Collector-Base Breakdown Voltage	V _{(BR)CBO}	-50	—	—	V	I _C = -10 μA, I _E = 0
Collector-Emitter Breakdown Voltage	V _{(BR)CEO}	-50	—	—	V	I _C = -2 mA, I _B = 0
Input Off Voltage	V _{I(OFF)}	—	-0.55	-0.3	V	V _{CE} = -5V, I _C = -100μA
Output Voltage	V _{OH}	-4.9	—	—	V	V _{CC} = -5V, V _B = -0.05V, R _L = 1K
Output Current (leakage current same as I _{CEO})	I _{O(OFF)}	—	—	-500	nA	V _{CC} = -50V, V _I = 0V
ON CHARACTERISTICS						
Collector-Emitter Saturation Voltage	V _{CE(SAT)}	—	—	-0.15	V	I _C = -10 mA, I _B = -0.5 mA
		—	—	-0.2	V	I _C = -50mA, I _B = -5mA
		—	—	-0.2	V	I _C = -20mA, I _B = -1mA
		—	—	-0.25	V	I _C = -100mA, I _B = -10mA
		—	—	-0.25	V	I _C = -200mA, I _B = -10mA
		—	—	-0.3	V	I _C = -200mA, I _B = -20mA
Equivalent On-Resistance*	R _{CE(SAT)}	—	—	1.5	Ω	I _C = -200mA, I _B = -10mA
DC Current Gain	h _{FE}	60	150	—	—	V _{CE} = -5V, I _C = -20 mA
		60	215	—	—	V _{CE} = -5V, I _C = -50 mA
		60	245	—	—	V _{CE} = -5V, I _C = -100 mA
		60	250	—	—	V _{CE} = -5V, I _C = -200 mA
Input On Voltage	V _{I(ON)}	-2.45	-0.7	—	V	V _O = -0.3V, I _C = -2 mA
Output Voltage (equivalent to V _{CE(SAT)} or V _{O(ON)})	V _{OL}	—	-0.065	-0.15	V	V _{CC} = -5V, V _B = -2.5V, I _O /I _I = -50mA / -2.5mA
Input Current	I _i	—	-9	-28	mA	V _I = -5V
Base-Emitter Turn-on Voltage	V _{BE(ON)}	—	-1.13	-1.3	V	V _{CE} = -5V, I _C = 200mA
Base-Emitter Saturation Voltage	V _{BE(SAT)}	—	-3.2	-3.6	V	I _C = -50mA, I _B = -5mA
		—	-4.6	-5.5		I _C = -80mA, I _B = -8mA
Input Resistor (Base), +/- 30%	R ₂	—	0.47	—	KΩ	—
Pull-up Resistor (Base to V _{CC} supply), +/- 30%	R ₁	—	10	—	KΩ	—
Resistor Ratio (Input Resistor/Pull-up resistor) +/- 20%	R ₁ /R ₂	—	21	—	—	—
SMALL SIGNAL CHARACTERISTICS						
Transition Frequency (Gain Bandwidth Product)	f _T	—	200	—	MHz	V _{CE} = -10V, I _E = -5mA, f = 100MHz
Collector Capacitance, (C _{cb0} -Output Capacitance)	C _C	—	20	—	pF	V _{CB} = -10V, I _E = 0A, f = 1MHz

* Pulse Test: Pulse width, tp < 300 μs, Duty Cycle, d <= 0.02

Electrical Characteristics: N-MOSFET with Gate Pull-Down Resistor (Q2)

@T_A = 25°C unless otherwise specified

Characteristic	Symbol	Min	Typ	Max	Unit	Test Condition
OFF CHARACTERISTICS (Note 4)						
Drain-Source Breakdown Voltage, BV _{DSS}	V _{(BR)DSS}	60	—	—	V	V _{GS} = 0V, I _D = 10μA
Zero Gate Voltage Drain Current (Drain Leakage Current)	I _{DSS}	—	—	1	μA	V _{GS} = 0V, V _{DS} = 60V
Gate-Body Leakage Current, Forward	I _{GSSF}	—	—	0.95	mA	V _{GS} = 20V, V _{DS} = 0V
Gate-Body Leakage Current, Reverse	I _{GSSR}	—	—	-0.95	mA	V _{GS} = -20V, V _{DS} = 0V
ON CHARACTERISTICS (Note 4)						
Gate Source Threshold Voltage (Control Supply Voltage)	V _{GS(th)}	1	1.9	2.2	V	V _{DS} = V _{GS} , I _D = 0.25mA
Static Drain-Source On-State Voltage	V _{DS(on)}	—	0.10	1.5	V	V _{GS} = 5V, I _D = 50mA
		—	0.15	3.75		V _{GS} = 10V, I _D = 115mA
On-State Drain Current	I _{D(on)}	500	—	—	mA	V _{GS} = 10V, V _{DS} ≥ 2×V _{DS(ON)}
Static Drain-Source On-Resistance	R _{DS(on)}	—	1.6	3	Ω	V _{GS} = 5V, I _D = 50mA
		—	1.4	2		V _{GS} = 10V, I _D = 500mA
Forward Transconductance	g _{FS}	80	240	—	mS	V _{DS} ≥ 2×V _{DS(ON)} , I _D = 115 mA
		80	350	—		V _{DS} ≥ 2×V _{DS(ON)} , I _D = 200 mA
Gate Pull-Down Resistor, +/- 30%	R3	—	37	—	KΩ	—
DYNAMIC CHARACTERISTICS						
Input Capacitance	C _{iss}	—	—	50	pF	V _{DS} = -25V, V _{GS} = 0V, f = 1MHz
Output Capacitance	C _{oss}	—	—	25	pF	
Reverse Transfer Capacitance	C _{rss}	—	—	5	pF	
SWITCHING CHARACTERISTICS						
Turn-On Delay Time	t _{D(on)}	—	—	20	ns	V _{DD} = 30V, V _{GS} = 10V, I _D = 200mA, R _G = 25 Ohm, R _L = 150 Ohm
Turn-Off Delay Time	t _{D(off)}	—	—	40	ns	
SOURCE-DRAIN (BODY) DIODE CHARACTERISTICS AND MAXIMUM RATINGS						
Drain-Source Diode Forward On-Voltage	V _{SD}	—	0.90	1.5	V	V _{GS} = 0V, I _S = 115 mA
Maximum Continuous Drain-Source Diode Forward Current (Reverse Drain Current)	I _S	—	—	115	mA	—
Maximum Pulsed Drain-Source Diode Forward Current	I _{SM}	—	—	800	mA	—

Notes: 4. Short duration pulse test used to minimize self-heating effect.

Typical Characteristics

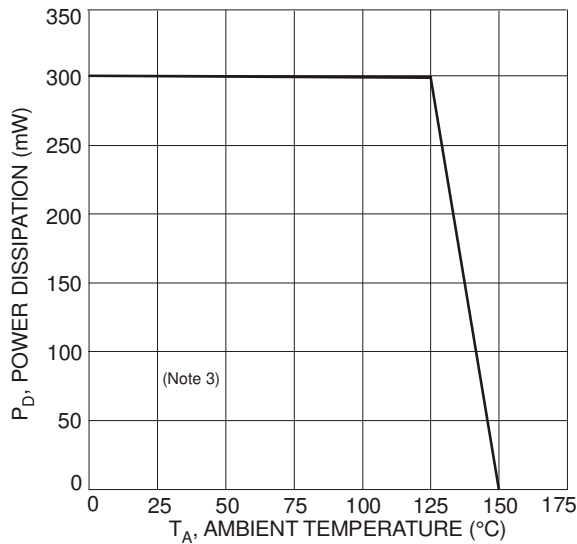

Fig. 3 Max Power Dissipation vs. Ambient Temperature (Total Device)

Typical Pre-Biased PNP Transistor (Q1) Characteristics

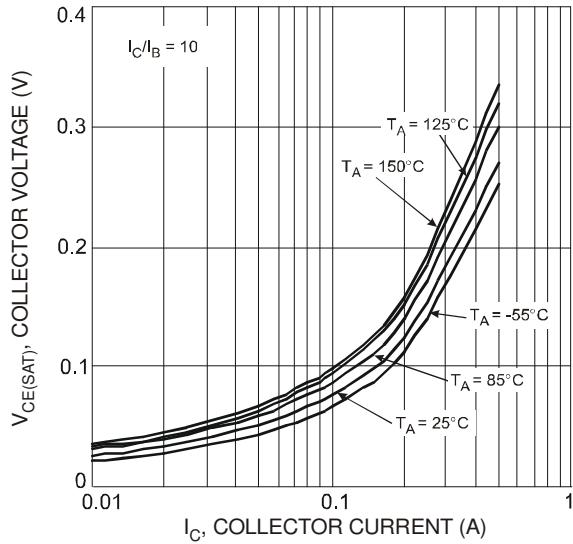

Fig. 4 $V_{CE(SAT)}$ vs. I_C

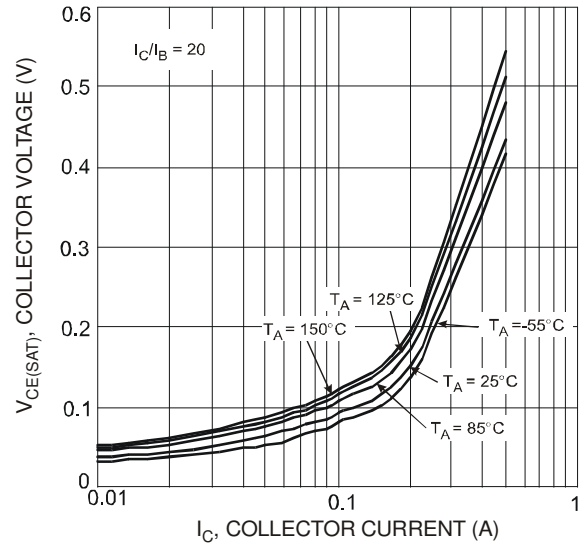

Fig. 5 $V_{CE(SAT)}$ vs. I_C

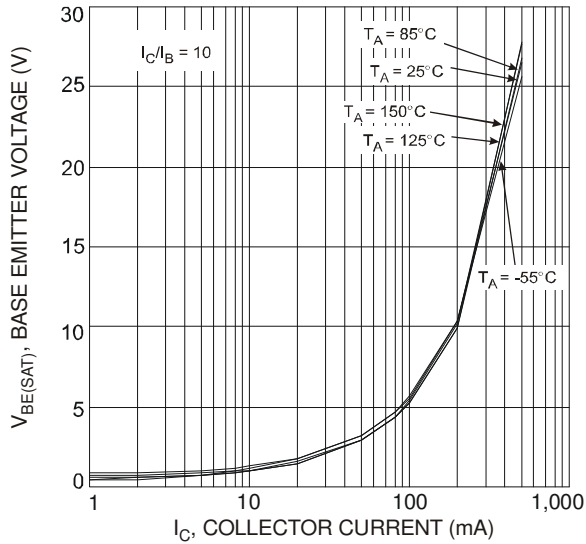

Fig. 6 $V_{BE(SAT)}$ vs. I_C

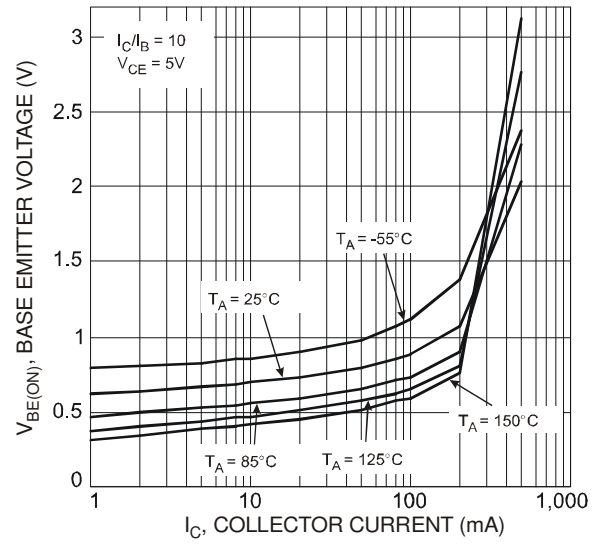

Fig. 7 $V_{BE(ON)}$ vs. I_C

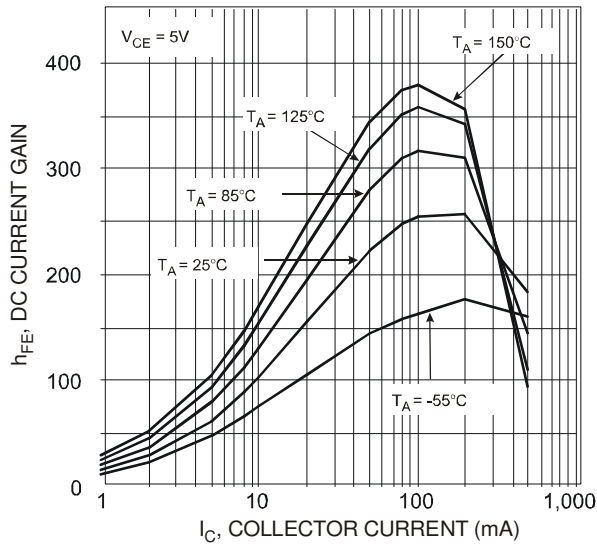

Fig. 8 h_{FE} vs. I_C

Typical N-Channel MOSFET (Q2) Characteristics

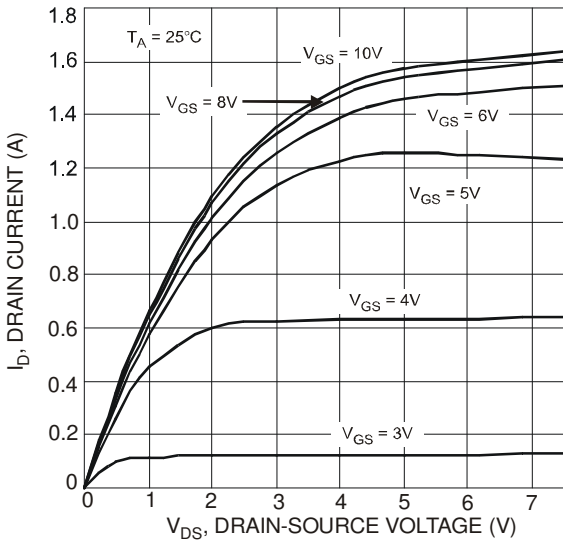

Fig. 9 Output Characteristics

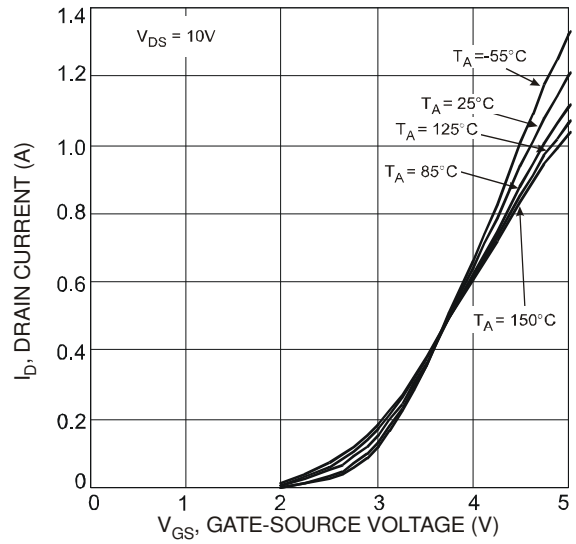

Fig. 10 Transfer Characteristics

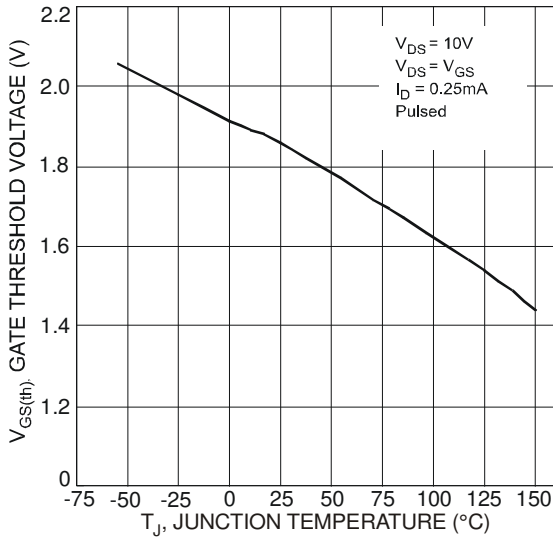

Fig. 11 Gate Threshold Voltage vs. Junction Temperature

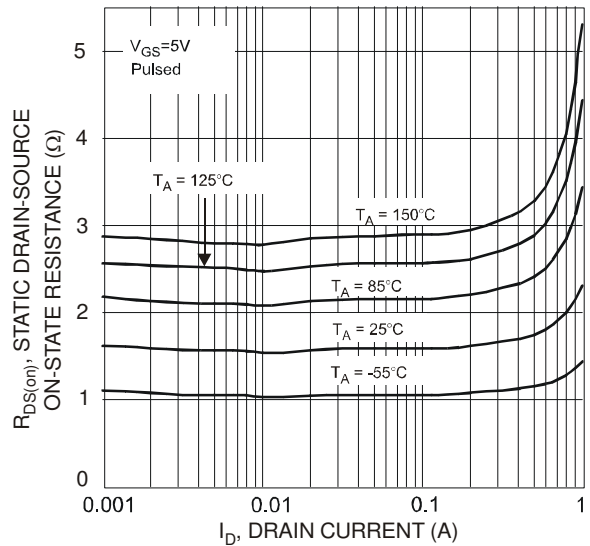

Fig. 12 Static Drain-Source On-Resistance vs. Drain Current

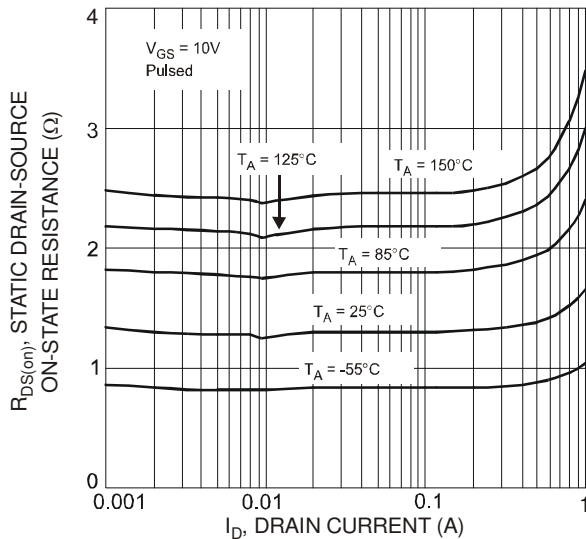

Fig. 13 Static Drain-Source On-Resistance vs. Drain Current

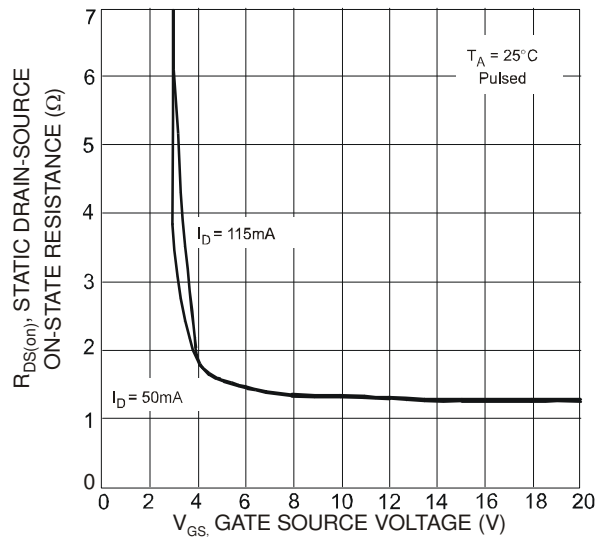

Fig. 14 Static Drain-Source On-Resistance vs. Gate-Source Voltage

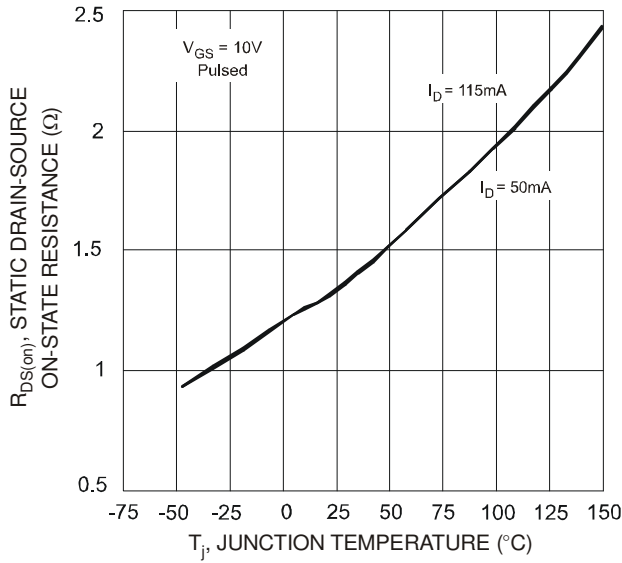

Fig. 15 Static Drain-Source On-State Resistance vs. Junction Temperature

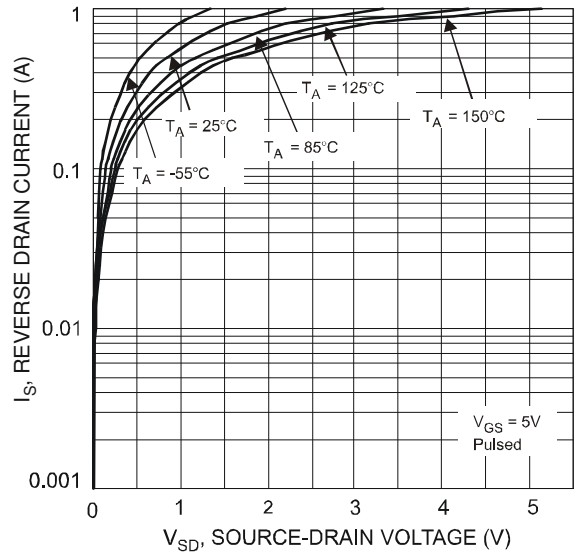

Fig. 16 Reverse Drain Current vs. Source-Drain Voltage

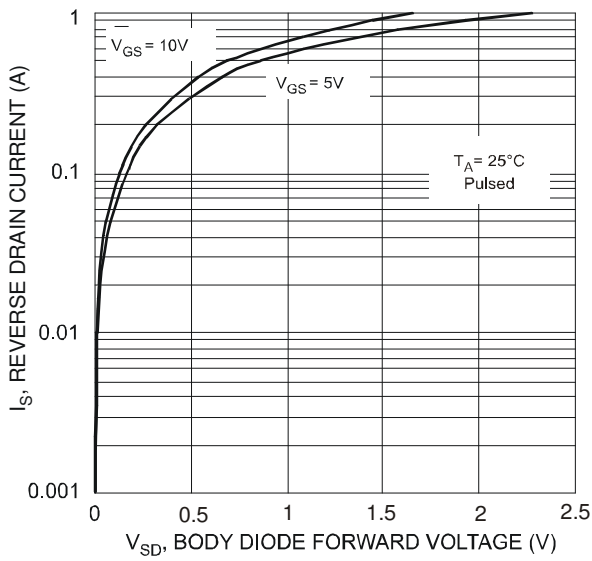

Fig. 17 Reverse Drain Current vs. Body Diode Forward Voltage

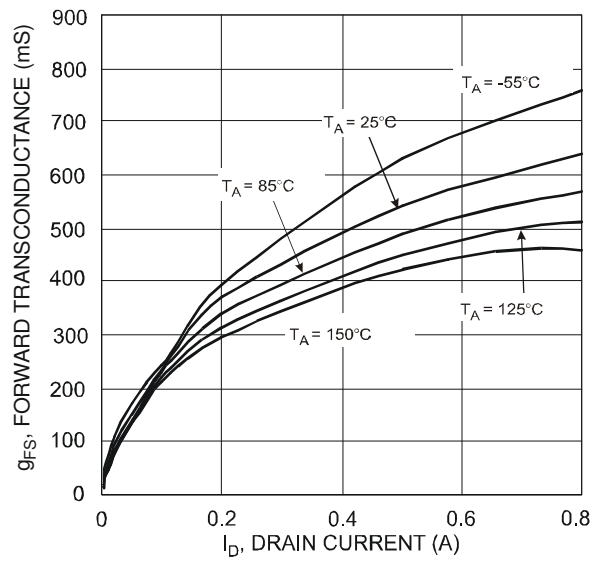

Fig. 18 Forward Transfer Conductance vs. Drain Current ($V_{DS} > I_D R_{DS(on)}$)

Application Details

PNP Transistor (DDTB142JU) and N-MOSFET (DSNM6047) with gate pull-down resistor integrated as one in LMN200B02 can be used as a discrete entity for general purpose applications or as an integrated circuit to function as a Load Switch. When it is used as the latter as shown in Fig 19, various input voltage sources can be used as long as it does not exceed the maximum ratings of the device. These devices are designed to deliver continuous output load current up to a maximum of 200 mA. The MOSFET Switch draws no current, hence loading of control circuit is prevented. Care must be taken for higher levels of dissipation while designing for higher load conditions. These devices provide high power and also consume less space. The product mainly helps in optimizing power usage, thereby conserving battery life in a controlled load system like portable battery powered applications. (Please see Fig. 20 for one example of a typical application circuit used in conjunction with voltage regulator as a part of a power management system)

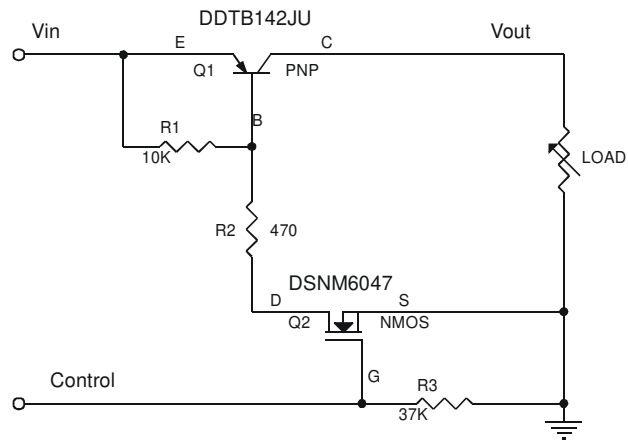

Fig. 19 Circuit Diagram

Typical Application Circuit

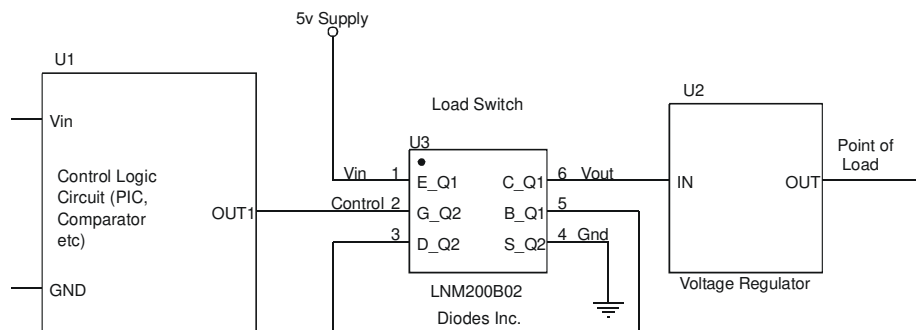

Fig. 20

Ordering Information (Note 5)

Device	Packaging	Shipping
LMN200B02-7	SOT-363	3000/Tape & Reel

Notes: 5. For packaging details, go to our website at <http://www.diodes.com/datasheets/ap02007.pdf>.

Marking Information

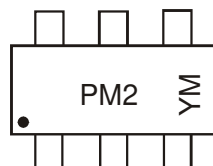

PM2 = Product Type Marking Code,
 YM = Date Code Marking
 Y = Year (ex: T = 2006)
 M = Month (ex: 9 = September)

Date Code Key

Year	2006	2007	2008	2009	2010	2011	2012	2013	2014	2015
Code	T	U	V	W	X	Y	Z	A	B	C

Month	Jan	Feb	Mar	Apr	May	Jun	Jul	Aug	Sep	Oct	Nov	Dec
Code	1	2	3	4	5	6	7	8	9	O	N	D

Mechanical Details

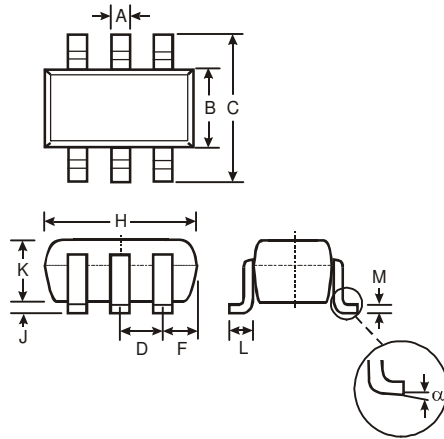

SOT-363		
Dim	Min	Max
A	0.10	0.30
B	1.15	1.35
C	2.00	2.20
D	0.65 Typ	
F	0.40	0.45
H	1.80	2.20
J	0	0.10
K	0.90	1.00
L	0.25	0.40
M	0.10	0.22
α	0°	8°
All Dimensions in mm		

Suggested Pad Layout

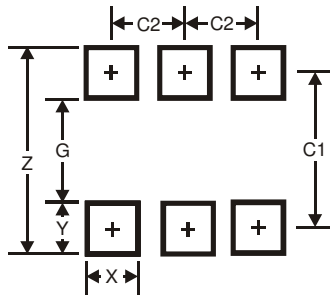

Dimensions	Value (in mm)
Z	2.5
G	1.3
X	0.42
Y	0.6
C1	1.9
C2	0.65

IMPORTANT NOTICE

DIODES INCORPORATED MAKES NO WARRANTY OF ANY KIND, EXPRESS OR IMPLIED, WITH REGARDS TO THIS DOCUMENT, INCLUDING, BUT NOT LIMITED TO, THE IMPLIED WARRANTIES OF MERCHANTABILITY AND FITNESS FOR A PARTICULAR PURPOSE (AND THEIR EQUIVALENTS UNDER THE LAWS OF ANY JURISDICTION).

Diodes Incorporated and its subsidiaries reserve the right to make modifications, enhancements, improvements, corrections or other changes without further notice to this document and any product described herein. Diodes Incorporated does not assume any liability arising out of the application or use of this document or any product described herein; neither does Diodes Incorporated convey any license under its patent or trademark rights, nor the rights of others. Any Customer or user of this document or products described herein in such applications shall assume all risks of such use and will agree to hold Diodes Incorporated and all the companies whose products are represented on Diodes Incorporated website, harmless against all damages.

Diodes Incorporated does not warrant or accept any liability whatsoever in respect of any products purchased through unauthorized sales channel. Should Customers purchase or use Diodes Incorporated products for any unintended or unauthorized application, Customers shall indemnify and hold Diodes Incorporated and its representatives harmless against all claims, damages, expenses, and attorney fees arising out of, directly or indirectly, any claim of personal injury or death associated with such unintended or unauthorized application.

Products described herein may be covered by one or more United States, international or foreign patents pending. Product names and markings noted herein may also be covered by one or more United States, international or foreign trademarks.

LIFE SUPPORT

Diodes Incorporated products are specifically not authorized for use as critical components in life support devices or systems without the express written approval of the Chief Executive Officer of Diodes Incorporated. As used herein:

A. Life support devices or systems are devices or systems which:

1. are intended to implant into the body, or
2. support or sustain life and whose failure to perform when properly used in accordance with instructions for use provided in the labeling can be reasonably expected to result in significant injury to the user.

B. A critical component is any component in a life support device or system whose failure to perform can be reasonably expected to cause the failure of the life support device or to affect its safety or effectiveness.

Customers represent that they have all necessary expertise in the safety and regulatory ramifications of their life support devices or systems, and acknowledge and agree that they are solely responsible for all legal, regulatory and safety-related requirements concerning their products and any use of Diodes Incorporated products in such safety-critical, life support devices or systems, notwithstanding any devices- or systems-related information or support that may be provided by Diodes Incorporated. Further, Customers must fully indemnify Diodes Incorporated and its representatives against any damages arising out of the use of Diodes Incorporated products in such safety-critical, life support devices or systems.

Copyright © 2009, Diodes Incorporated

www.diodes.com