



Chipsmall Limited consists of a professional team with an average of over 10 year of expertise in the distribution of electronic components. Based in Hongkong, we have already established firm and mutual-benefit business relationships with customers from,Europe,America and south Asia,supplying obsolete and hard-to-find components to meet their specific needs.

With the principle of "Quality Parts,Customers Priority,Honest Operation,and Considerate Service",our business mainly focus on the distribution of electronic components. Line cards we deal with include Microchip,ALPS,ROHM,Xilinx,Pulse,ON,Everlight and Freescale. Main products comprise IC,Modules,Potentiometer,IC Socket,Relay,Connector.Our parts cover such applications as commercial,industrial, and automotives areas.

We are looking forward to setting up business relationship with you and hope to provide you with the best service and solution. Let us make a better world for our industry!



Contact us

Tel: +86-755-8981 8866 Fax: +86-755-8427 6832

Email & Skype: info@chipsmall.com Web: www.chipsmall.com

Address: A1208, Overseas Decoration Building, #122 Zhenhua RD., Futian, Shenzhen, China



小

形

Small Type

ダブルエンド Double End

Type No. Lighting Color
 LN247RP Red
 LN347GP Green
 LN447YP Amber

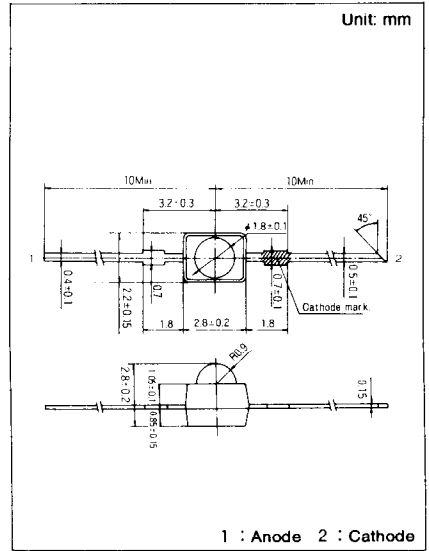

絶対最大定格 Absolute Maximum Ratings (Ta=25 °C)

Lighting Color	P _D (mW)	I _F (mA)	I _{FP} (mA)*	V _R (V)	Topr (°C)	Tstg (°C)
Red	70	25	100	4	-25~+85	-30~+100
Green	90	30	100	4	-25~+85	-30~+100
Amber	90	30	100	4	-25~+85	-30~+100

* I_{FP}の条件は, duty 10%, Pulse width 1 msec. The condition of I_{FP} is duty 10%, Pulse width 1 msec

電気的光学的特性 Electro-Optical Characteristics (Ta=25 °C)

Type No.	Lighting Color	Lens Color	I ₀			V _F		λ _P	Δλ	I _F	I _R	
			Typ.	Min.	I _F	Typ.	Max.				I _F	Max.
LN247RP	Red	Red Diffused	0.7	0.25	15	2.2	2.8	700	100	20	10	4
LN347GP	Green	Green Diffused	4.5	1.50	20	2.2	2.8	565	30	20	10	4
LN447YP	Amber	Amber Diffused	4.0	1.00	20	2.2	2.8	590	30	20	10	4
Unit	—	—	mcd	mcd	mA	V	V	nm	nm	mA	μA	V

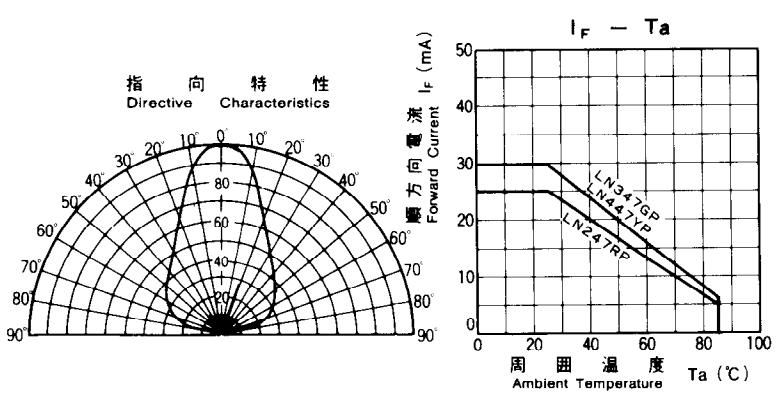
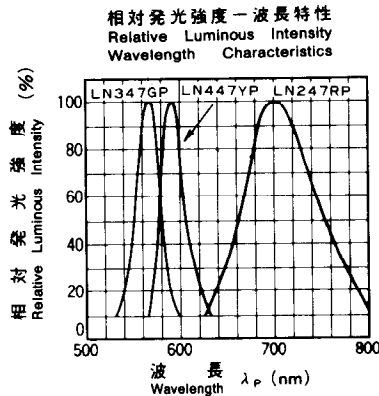
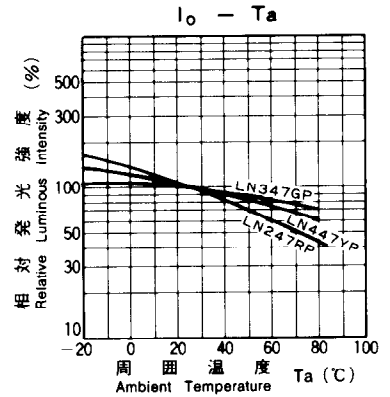
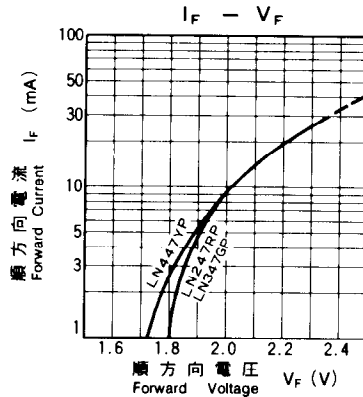
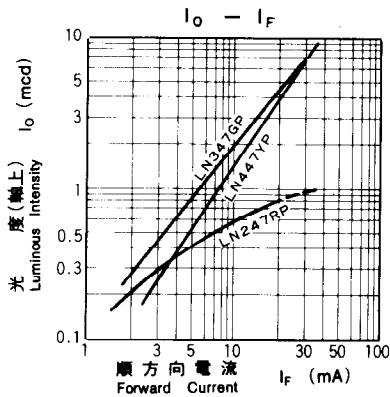

指向特性 Directive Characteristics

