



Chipsmall Limited consists of a professional team with an average of over 10 year of expertise in the distribution of electronic components. Based in Hongkong, we have already established firm and mutual-benefit business relationships with customers from,Europe,America and south Asia,supplying obsolete and hard-to-find components to meet their specific needs.

With the principle of "Quality Parts,Customers Priority,Honest Operation,and Considerate Service",our business mainly focus on the distribution of electronic components. Line cards we deal with include Microchip,ALPS,ROHM,Xilinx,Pulse,ON,Everlight and Freescale. Main products comprise IC,Modules,Potentiometer,IC Socket,Relay,Connector.Our parts cover such applications as commercial,industrial, and automotives areas.

We are looking forward to setting up business relationship with you and hope to provide you with the best service and solution. Let us make a better world for our industry!



Contact us

Tel: +86-755-8981 8866 Fax: +86-755-8427 6832

Email & Skype: info@chipsmall.com Web: www.chipsmall.com

Address: A1208, Overseas Decoration Building, #122 Zhenhua RD., Futian, Shenzhen, China



Transil™ for low noise block protection

Datasheet - production data

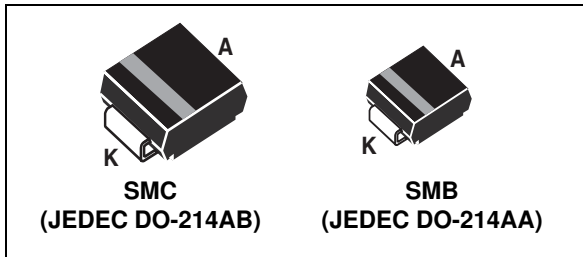

Description

The LNBTVS series has been designed to protect LNB voltage regulators in satellite set top boxes against electrostatic discharges according to IEC 61000-4-2, and MIL STD 883, method 3015, and electrical over stress according to IEC 61000-4-4 and 5. These devices can protect against surges up to 6 kV over the whole consumer temperature range (up to 85 °C).

Planar technology makes these devices suitable for high-end set top boxes to provide reliability and stability over time.

LNBTVS are packaged in either SMB or SMC (footprints in accordance with IPC 7531 standard).

Features

- Peak pulse power:
 - up to 3 kW (10/1000 μ s)
 - up to 22.5 kW (8/20 μ s)
- Breakdown voltage range: from 23.1 V to 30 V
- Low clamping factor
- Unidirectional with low V_F ($V_F = 1.2$ V at 3 A)
- Low leakage current: 0.2 μ A at 25 °C
- Operating $T_{j\max}$: 150 °C
- Still IEC 61000-4-5 compliant at $T_j = 85$ °C with standard footprint
- High power capability at $T_{j\max}$:
 - 1250 W (10/1000 μ s)
- JEDEC registered package outline
- Compatible with LNBH supply and control ICs

Table 1. Device summary

Part number	I_{PP} A (8/20 μ s, IEC 61000-4-5)	Package
LNBTVS3	250 (3 kV, 12 Ω)	SMB
LNBTVS4	334 (4 kV, 12 Ω)	SMC
LNBTVS6	500 (6 kV, 12 Ω)	SMC

Complies with the following standards

- IEC 61000-4-2 level 4:
 - 15 kV (air discharge)
 - 8 kV (contact discharge)
- IEC 61000-4-5
- MIL STD 883G, method 3015-7: class 3B:
 - 25 kV HBM (human body model)
- Resin meets UL 94, V0
- MIL-STD-750, method 2026 solderability
- EIA STD RS-481 and IEC 60286-3 packing
- IPC 7531 footprint

TM: Transil is a trademark of STMicroelectronics

1 Characteristics

Table 2. Absolute maximum ratings ($T_{amb} = 25\text{ }^{\circ}\text{C}$)

Symbol	Parameter	Value	Unit	
P_{PP}	Peak pulse power dissipation ⁽¹⁾ (8/20 μs)	$T_{j\text{ initial}} = T_{amb}$	up to 22.5	kW
T_{stg}	Storage temperature range		-65 to + 150	$^{\circ}\text{C}$
T_j	Operating junction temperature range		-55 to + 150	$^{\circ}\text{C}$
T_L	Maximum lead temperature for soldering during 10 s.		260	$^{\circ}\text{C}$

1. For a surge greater than the maximum values, the diode will fail in short-circuit.

Table 3. Thermal parameter

Symbol	Parameter	Value	Unit	
$R_{th(j-l)}$	Junction to leads	SMC	15	$^{\circ}\text{C}/\text{W}$
		SMB	20	$^{\circ}\text{C}/\text{W}$

Figure 1. Electrical characteristics - definitions

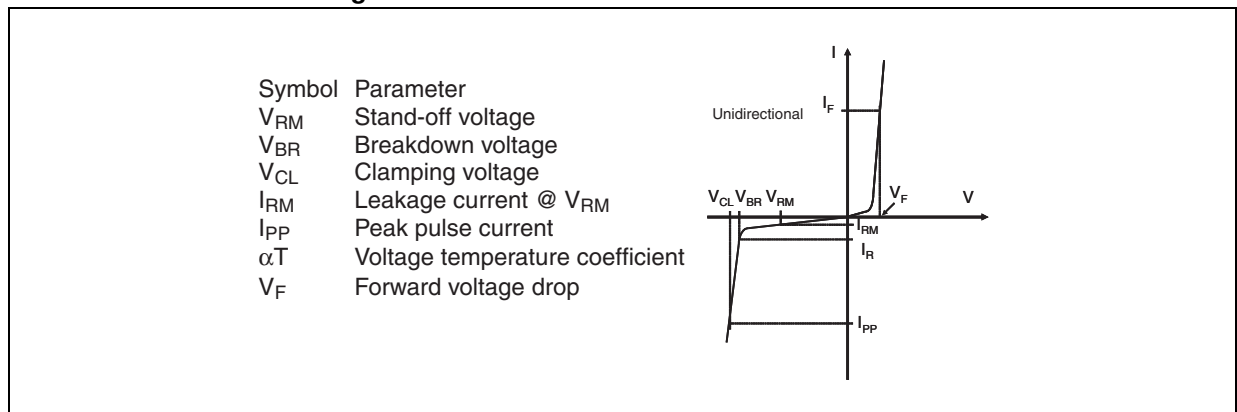

Figure 2. Pulse definition for electrical characteristics

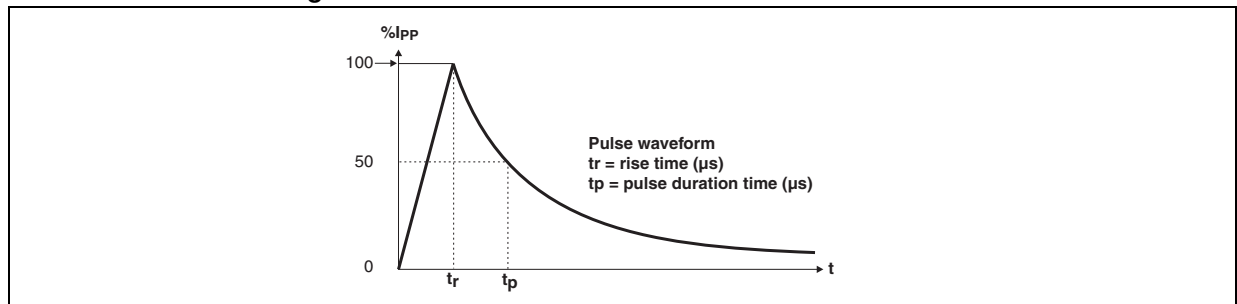

Table 4. Electrical characteristics, parameter values ($T_{amb} = 25\text{ }^{\circ}\text{C}$)

Order code	$I_{RM} \text{ max @ } V_{RM}$			$V_{BR} \text{ @ } I_R$				$V_{CL} \text{ @ } I_{PP}$ 10/1000 μs		$V_{CL} \text{ @ } I_{PP}$ 8/20 μs		$\alpha T^{(1)}$	C
	25 $^{\circ}\text{C}$	85 $^{\circ}\text{C}$		min.	typ.	max.		max.		max.		max.	typ.
	μA		V	V			mA	V	A ⁽²⁾	V	A ⁽²⁾	10-4/ $^{\circ}\text{C}$	nF
LNBTVS3-220U	0.2	1.0	20	22	23.1	24.2	1	33.2	45	35	250	9.3	3
LNBTVS4-220S	0.2	1.0	20	22	23.1	24.2	1	33.2	55	35	334	9.3	3.5
LNBTVS4-221S	0.2	1.0	20	22	23.1	24.2	1	33.2	60	32	334	9.3	5.5
LNBTVS4-222S	0.2	1.0	20	22	23.1	24.2	1	33.2	90	30	334	9.3	6
LNBTVS4-304S	0.2	1.0	28	30	31.5	33	1	45	56	45	334	9.8	4
LNBTVS6-220S	0.2	1.0	20	22	23.1	24.2	1	33.2	90	35	500	9.3	6
LNBTVS6-221S	0.2	1.0	20	22	23.1	24.2	1	33.2	90	32	500	9.3	6
LNBTVS6-304S	0.2	1.0	28	30	31.5	33	1	45	67	45	500	9.8	5

1. To calculate V_{BR} versus junction temperature, use the following formula: $V_{BR} \text{ @ } T_J = V_{BR} \text{ @ } 25^{\circ}\text{C} \times (1 + \alpha T \times (T_J - 25))$.
2. Surge capability given for both directions.

Figure 3. Peak pulse current versus initial junction temperature with regular footprints (typical values)

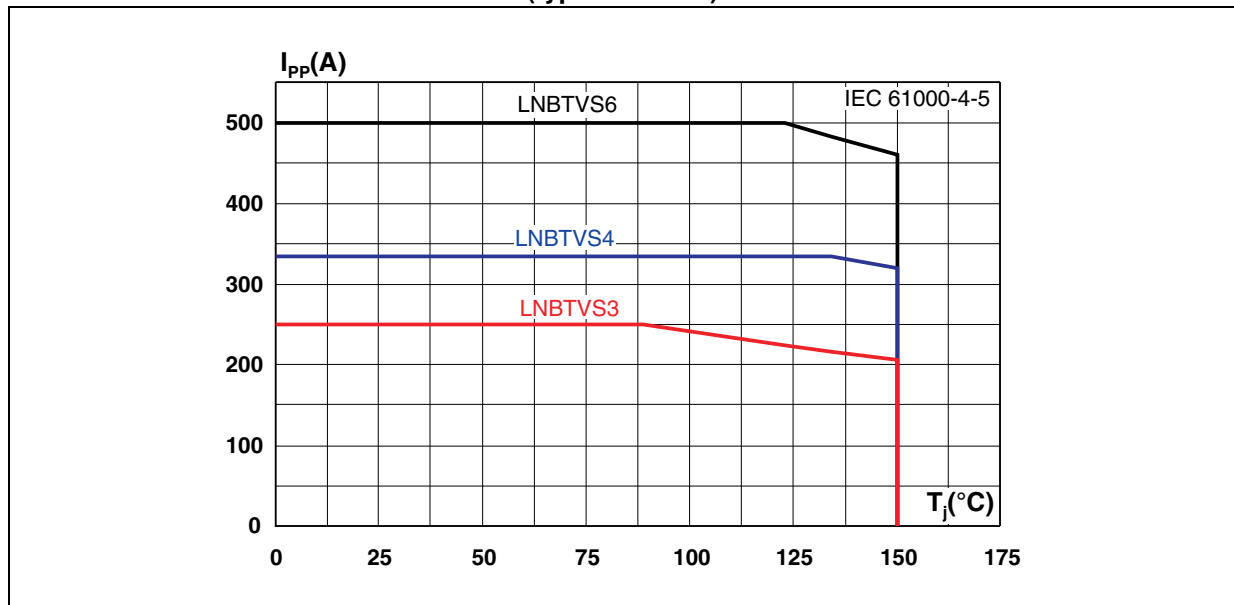

Figure 4. Surge test examples at +4 kV - IEC 61000-4-5, R = 12 Ω

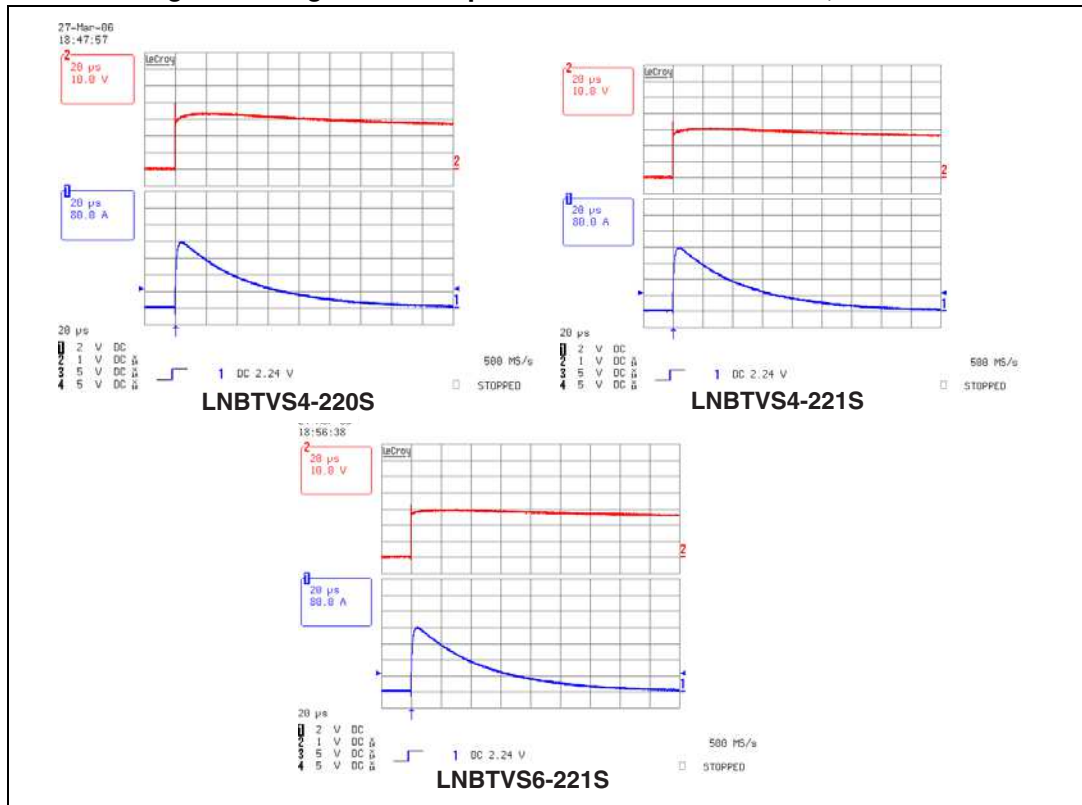
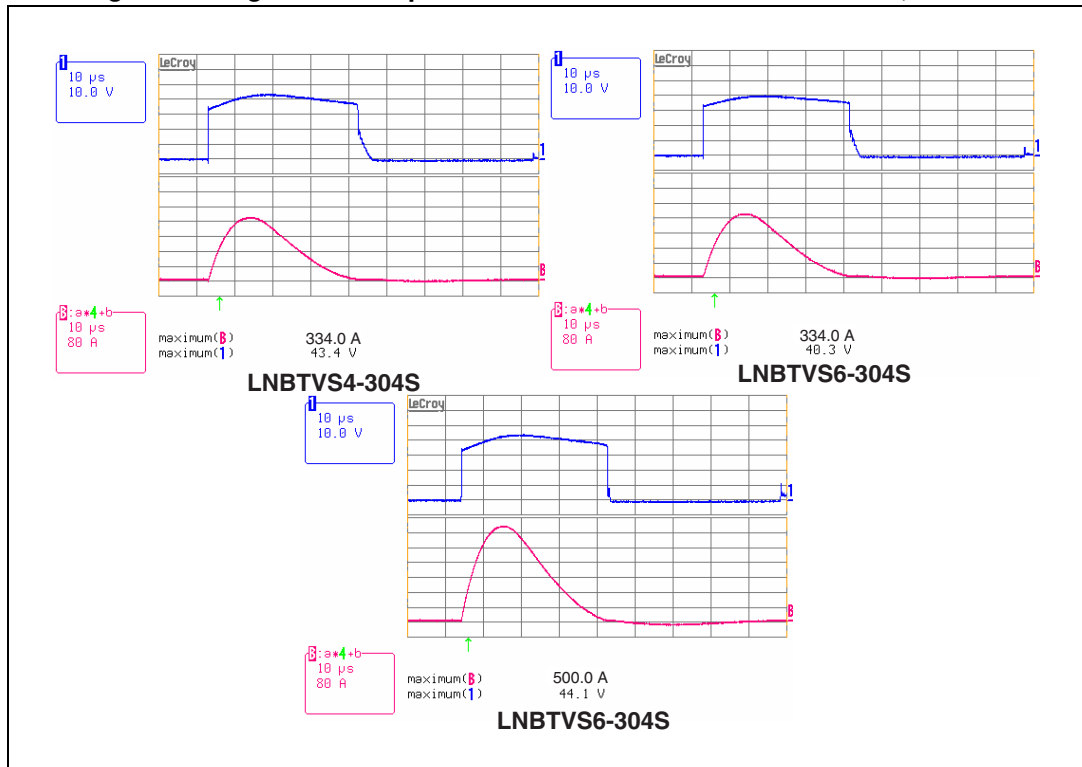

Figure 5. Surge test examples at 334 A and 500 A - IEC 61000-4-5, R = 2 Ω



2 Application information

Figure 6. Application schematic with LNBH23 and LNBTVSx

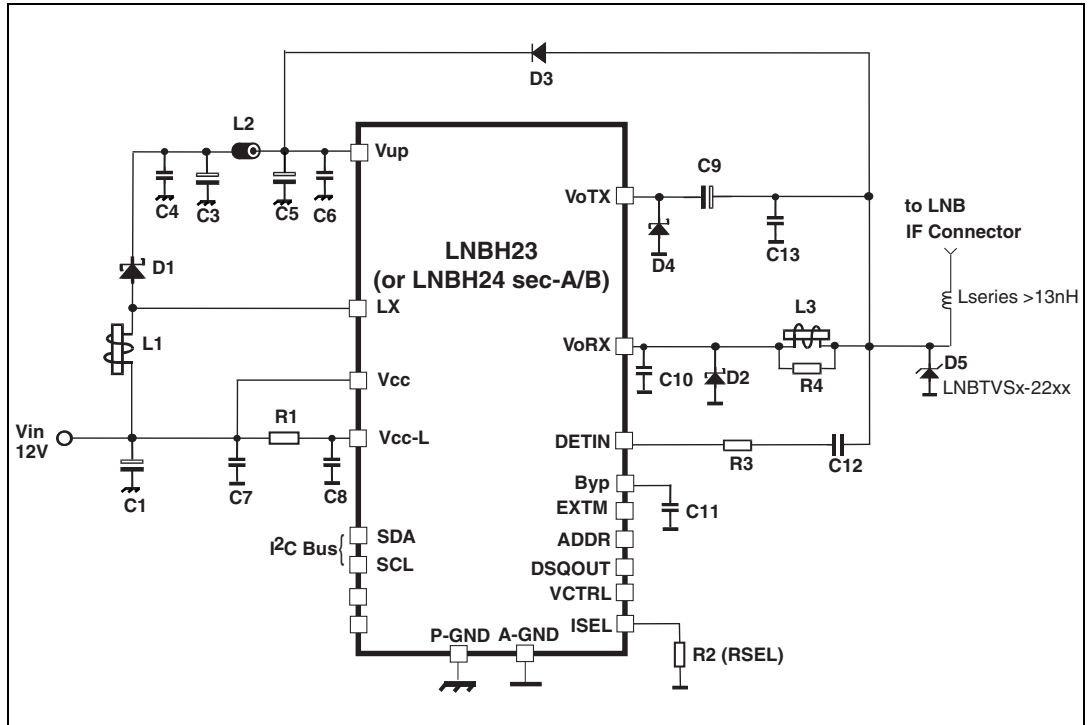

Figure 7. Application schematic with LNBH23L and LNBTVSx

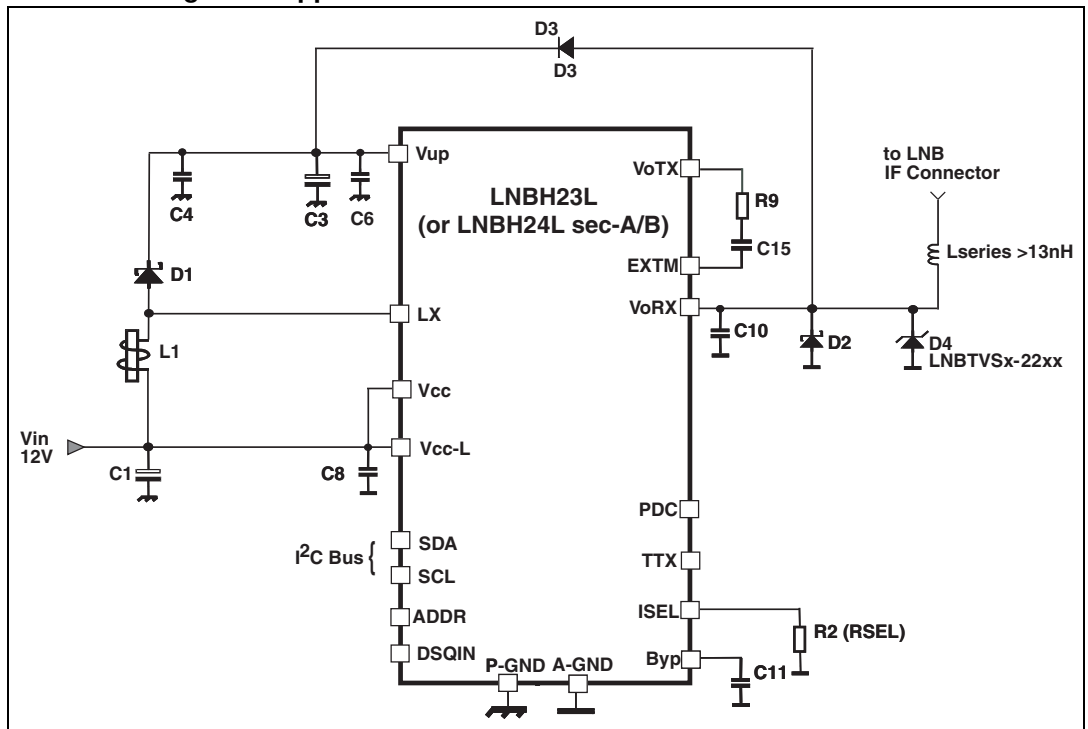
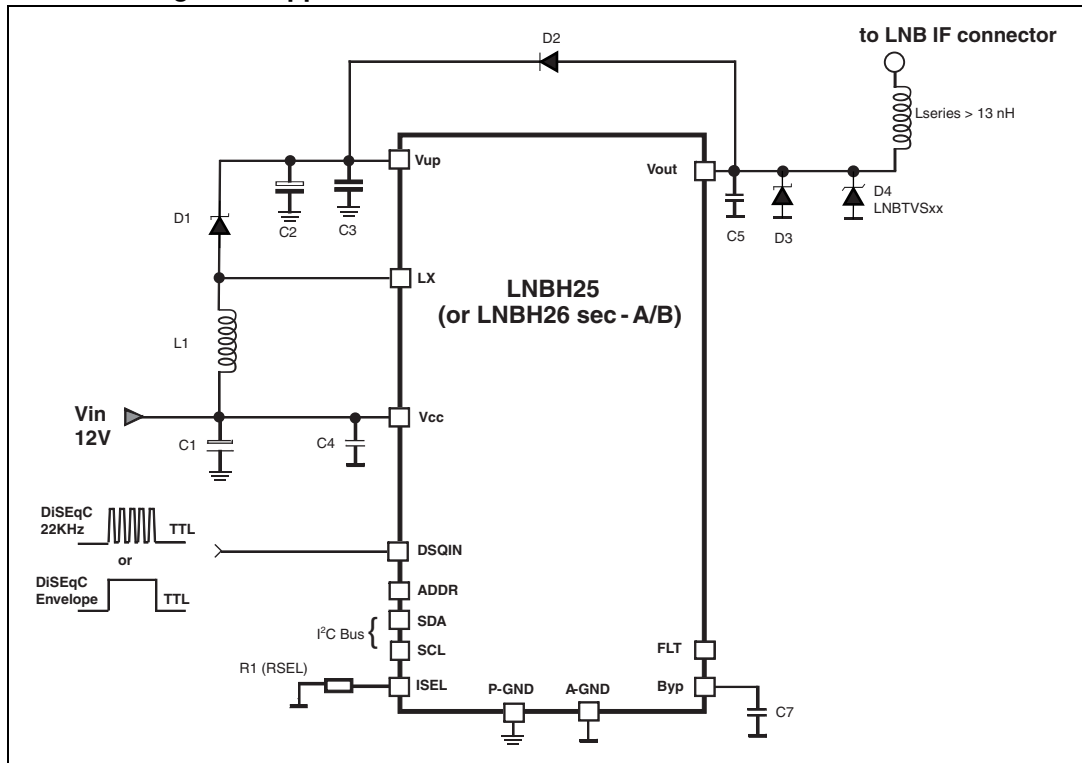

Figure 8. Application schematic with LNBH25/26 and LNBTVSx



LNBHxx output is usually connected to the antenna cable of digital satellite receivers. Atmospheric phenomenon can cause high voltage discharges on the antenna cable causing damages to the attached devices.

In applications where it is required to be protected against lightning surges, transient voltage suppressor (TVS) devices like LNBTVSx-22xx can be used to protect LNBHxx and the other devices electrically connected to the antenna cable.

The LNBTVSx-22xx diodes are dedicated lightning and electrical overstress surge protection for LNBHxx voltage regulators. These protection diodes were designed to comply with the stringent IEC 61000-4-5 standard with surges up to 500 A with a whole range of products.

TVS diodes have intrinsic capacitance that attenuates the RF signal. For this reason, the LNBTVSx-22xx cannot be directly connected to the IF (RX/TX) cable connector that carries the RF signals coming from the LNB. To suppress the effect of the intrinsic capacitance, an inductance must be placed in series with the TVS diode (see [Figure 9](#)). The goal of the L series and LNBTVC inductance is to be transparent at 22 kHz and to reject frequencies higher than 900 MHz.

The value of the series inductance is usually > 13 nH, with a current capability higher than the I_{pp} (peak pulse current) expected during the surge.

Figure 9. Example of LNBTVS diode connection

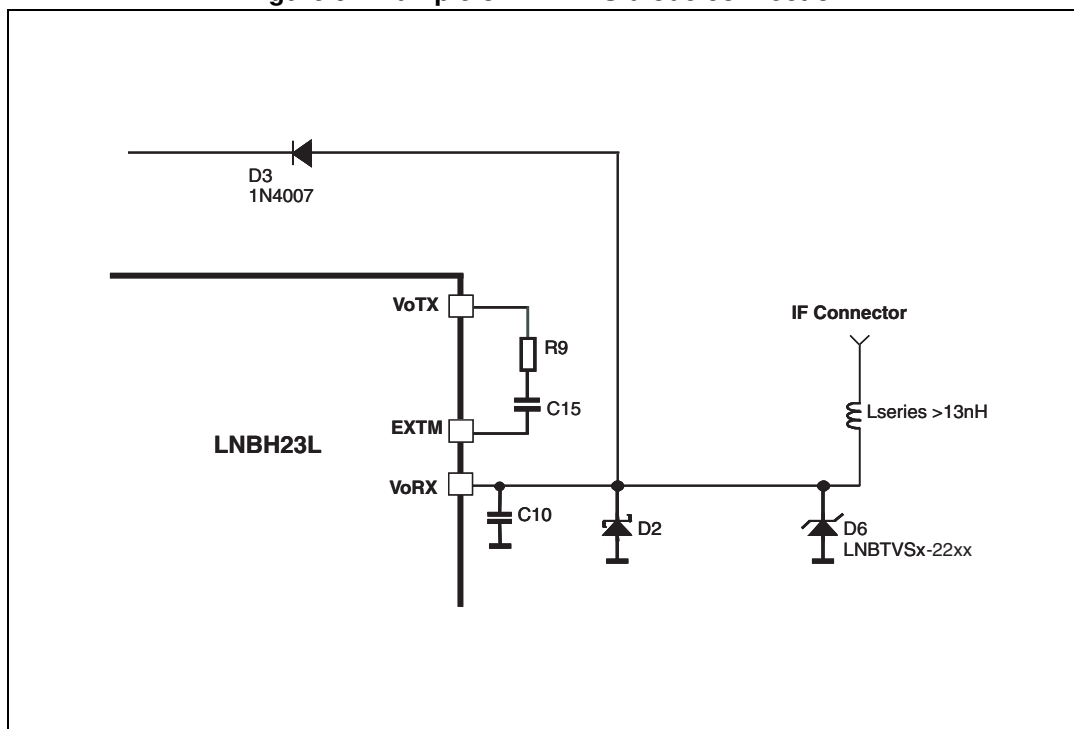

3 Package information

- Case: JEDEC DO-214AB or JEDEC DO-214AA molded plastic over planar junction
- Terminals: solder plated, solderable as per MIL-STD-750, Method 2026
- Polarity: for unidirectional types the band indicates cathode
- Flammability: epoxy is rated UL 94, V0
- RoHS package

In order to meet environmental requirements, ST offers these devices in different grades of ECOPACK® packages, depending on their level of environmental compliance. ECOPACK® specifications, grade definitions and product status are available at: www.st.com. ECOPACK® is an ST trademark.

Figure 10. SMC dimension definitions

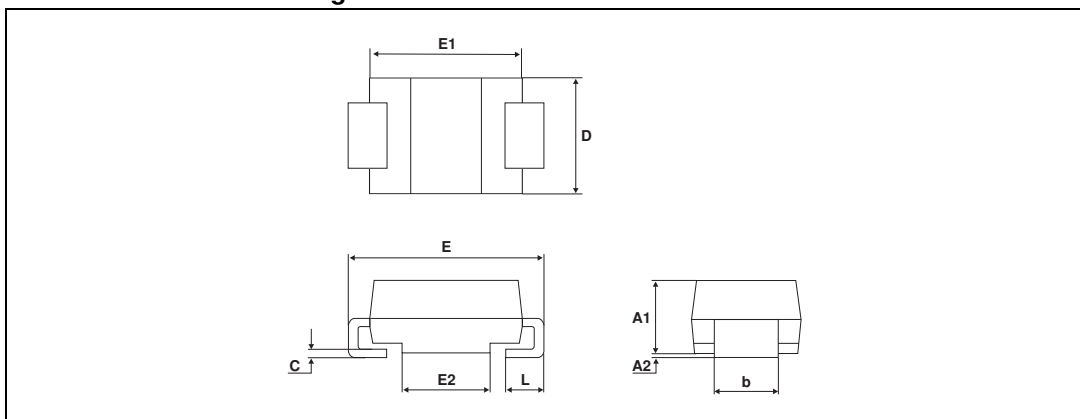

Table 5. SMC dimension values

Ref.	Dimensions			
	Millimeters		Inches	
	Min.	Max.	Min.	Max.
A1	1.90	2.45	0.075	0.096
A2	0.05	0.20	0.002	0.008
b	2.90	3.20	0.114	0.126
c	0.15	0.40	0.006	0.016
D	5.55	6.25	0.218	0.246
E	7.75	8.15	0.305	0.321
E1	6.60	7.15	0.260	0.281
E2	4.40	4.70	0.173	0.185
L	0.75	1.50	0.030	0.059

Figure 11. SMB dimension definitions

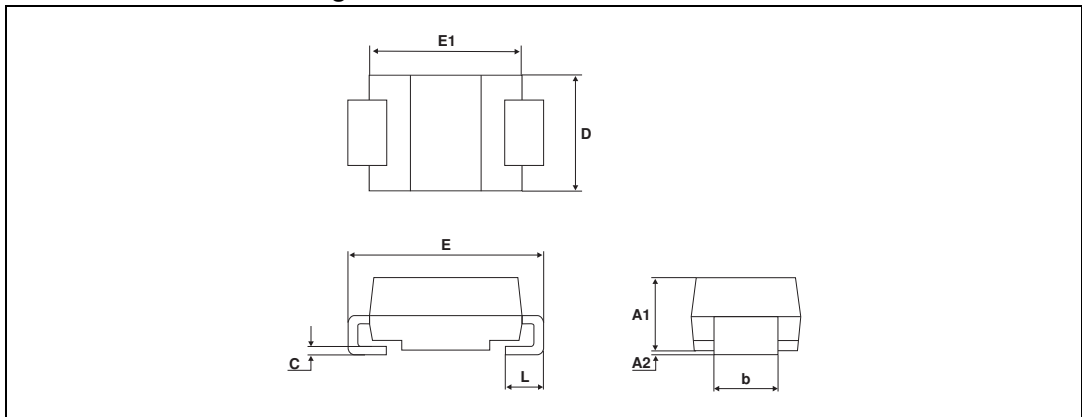

Table 6. SMB dimension values

Ref.	Dimensions			
	Millimeters		Inches	
	Min.	Max.	Min.	Max.
A1	1.90	2.45	0.075	0.096
A2	0.05	0.20	0.002	0.008
b	1.95	2.20	0.077	0.087
c	0.15	0.40	0.006	0.016
D	3.30	3.95	0.130	0.156
E	5.10	5.60	0.201	0.220
E1	4.05	4.60	0.159	0.181
L	0.75	1.50	0.030	0.059

Figure 12. SMC footprint dimensions in mm (inches)

Figure 13. SMB footprint dimensions in mm (inches)

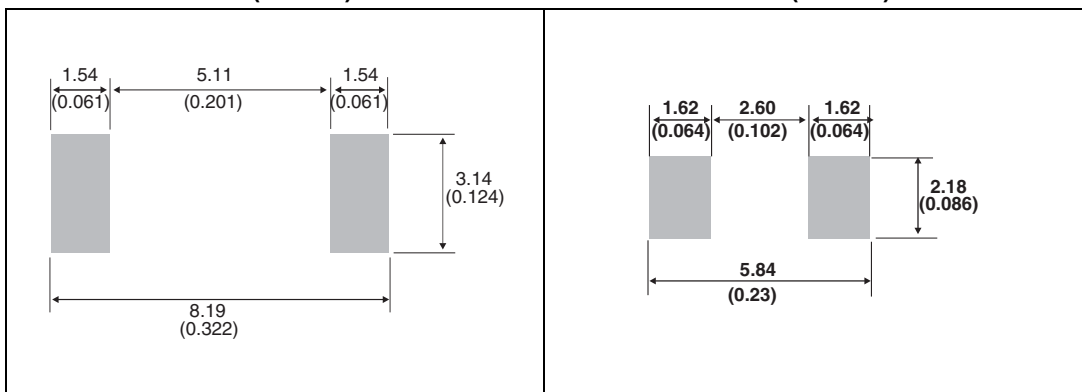
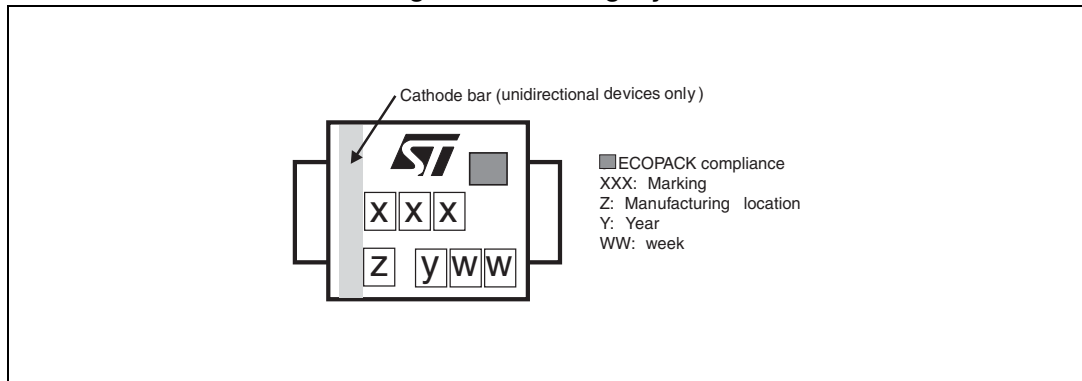

Figure 14. Marking layout



Note: Marking layout can vary according to assembly location.

4 Ordering information

Figure 15. Ordering information scheme

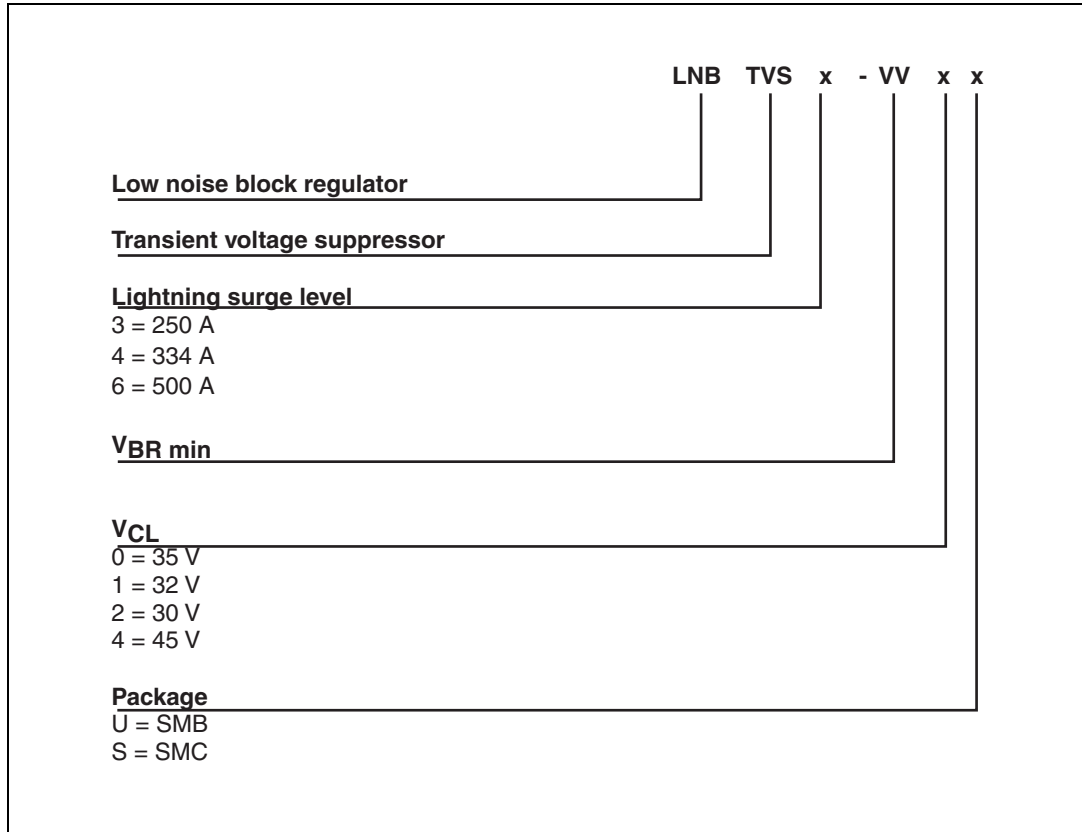

Table 7. Ordering information

Order code	Marking	Package	Weight (g)	Base qty	Delivery mode
LNBTVS3-220U	LC	SMB	0.107	2500	Tape and reel
LNBTVS4-220S	LAA	SMC	0.245	2500	Tape and reel
LNBTVS4-221S	LAB	SMC	0.245	2500	Tape and reel
LNBTVS4-222S	LAC	SMC	0.245	2500	Tape and reel
LNBTVS6-220S	LBA	SMC	0.245	2500	Tape and reel
LNBTVS6-221S	LBB	SMC	0.245	2500	Tape and reel
LNBTVS4-304S	LAD	SMC	0.245	2500	Tape and reel
LNBTVS6-304S	LBC	SMC	0.245	2500	Tape and reel

5 Revision history

Table 8. Document revision history

Date	Revision	Changes
30-Aug-2010	1	First release. This document merges and updates the content of datasheets LNBTVSx-22xx Revision 3, 20-Jan-2007, and LNBTVSx-304 Revision 1, 01-Apr-2008.
22-Oct-2010	2	Updated Figure 13 .
05-Sep-2011	3	Added Figure 8 .
21-May-2013	4	Added Table 1: Device summary .

Please Read Carefully:

Information in this document is provided solely in connection with ST products. STMicroelectronics NV and its subsidiaries ("ST") reserve the right to make changes, corrections, modifications or improvements, to this document, and the products and services described herein at any time, without notice.

All ST products are sold pursuant to ST's terms and conditions of sale.

Purchasers are solely responsible for the choice, selection and use of the ST products and services described herein, and ST assumes no liability whatsoever relating to the choice, selection or use of the ST products and services described herein.

No license, express or implied, by estoppel or otherwise, to any intellectual property rights is granted under this document. If any part of this document refers to any third party products or services it shall not be deemed a license grant by ST for the use of such third party products or services, or any intellectual property contained therein or considered as a warranty covering the use in any manner whatsoever of such third party products or services or any intellectual property contained therein.

UNLESS OTHERWISE SET FORTH IN ST'S TERMS AND CONDITIONS OF SALE ST DISCLAIMS ANY EXPRESS OR IMPLIED WARRANTY WITH RESPECT TO THE USE AND/OR SALE OF ST PRODUCTS INCLUDING WITHOUT LIMITATION IMPLIED WARRANTIES OF MERCHANTABILITY, FITNESS FOR A PARTICULAR PURPOSE (AND THEIR EQUIVALENTS UNDER THE LAWS OF ANY JURISDICTION), OR INFRINGEMENT OF ANY PATENT, COPYRIGHT OR OTHER INTELLECTUAL PROPERTY RIGHT.

ST PRODUCTS ARE NOT AUTHORIZED FOR USE IN WEAPONS. NOR ARE ST PRODUCTS DESIGNED OR AUTHORIZED FOR USE IN: (A) SAFETY CRITICAL APPLICATIONS SUCH AS LIFE SUPPORTING, ACTIVE IMPLANTED DEVICES OR SYSTEMS WITH PRODUCT FUNCTIONAL SAFETY REQUIREMENTS; (B) AERONAUTIC APPLICATIONS; (C) AUTOMOTIVE APPLICATIONS OR ENVIRONMENTS, AND/OR (D) AEROSPACE APPLICATIONS OR ENVIRONMENTS. WHERE ST PRODUCTS ARE NOT DESIGNED FOR SUCH USE, THE PURCHASER SHALL USE PRODUCTS AT PURCHASER'S SOLE RISK, EVEN IF ST HAS BEEN INFORMED IN WRITING OF SUCH USAGE, UNLESS A PRODUCT IS EXPRESSLY DESIGNATED BY ST AS BEING INTENDED FOR "AUTOMOTIVE, AUTOMOTIVE SAFETY OR MEDICAL" INDUSTRY DOMAINS ACCORDING TO ST PRODUCT DESIGN SPECIFICATIONS. PRODUCTS FORMALLY ESCC, QML OR JAN QUALIFIED ARE DEEMED SUITABLE FOR USE IN AEROSPACE BY THE CORRESPONDING GOVERNMENTAL AGENCY.

Resale of ST products with provisions different from the statements and/or technical features set forth in this document shall immediately void any warranty granted by ST for the ST product or service described herein and shall not create or extend in any manner whatsoever, any liability of ST.

ST and the ST logo are trademarks or registered trademarks of ST in various countries.

Information in this document supersedes and replaces all information previously supplied.

The ST logo is a registered trademark of STMicroelectronics. All other names are the property of their respective owners.

© 2013 STMicroelectronics - All rights reserved

STMicroelectronics group of companies

Australia - Belgium - Brazil - Canada - China - Czech Republic - Finland - France - Germany - Hong Kong - India - Israel - Italy - Japan - Malaysia - Malta - Morocco - Philippines - Singapore - Spain - Sweden - Switzerland - United Kingdom - United States of America

www.st.com

