



Chipsmall Limited consists of a professional team with an average of over 10 year of expertise in the distribution of electronic components. Based in Hongkong, we have already established firm and mutual-benefit business relationships with customers from,Europe,America and south Asia,supplying obsolete and hard-to-find components to meet their specific needs.

With the principle of “Quality Parts,Customers Priority,Honest Operation,and Considerate Service”,our business mainly focus on the distribution of electronic components. Line cards we deal with include Microchip,ALPS,ROHM,Xilinx,Pulse,ON,Everlight and Freescale. Main products comprise IC,Modules,Potentiometer,IC Socket,Relay,Connector.Our parts cover such applications as commercial,industrial, and automotives areas.

We are looking forward to setting up business relationship with you and hope to provide you with the best service and solution. Let us make a better world for our industry!



## Contact us

Tel: +86-755-8981 8866 Fax: +86-755-8427 6832

Email & Skype: info@chipsmall.com Web: www.chipsmall.com

Address: A1208, Overseas Decoration Building, #122 Zhenhua RD., Futian, Shenzhen, China



# Multi TOPLED® Bright Green Die

LOG T671, LSG T671



**Non-RoHS compliant version of product will be discontinued acc. to OS-PD-2005-005.  
The product itself will remain within RoHS compliant version.**

## Besondere Merkmale

- **Gehäusetypp:** weißes P-LCC-4 Gehäuse, farbloser klarer Verguss
- **Besonderheit des Bauteils:** extrem breite Abstrahlcharakteristik; ideal für Hinterleuchtungen und Einkopplungen in Lichtleiter
- **Wellenlänge:** 628 nm (super-rot), 606 nm (orange), 570 nm (grün)
- **Abstrahlwinkel:** Lambertscher Strahler (120°)
- **Technologie:** GaAIP
- **optischer Wirkungsgrad:** 1,5 lm/W (super-rot, orange), 2,5 lm/W (grün)
- **Gruppierungsparameter:** Lichtstärke
- **Verarbeitungsmethode:** für alle SMT-Bestücktechniken geeignet
- **Lötmethode:** IR Reflow Löten und Wellenlöten (TTW)
- **Vorbehandlung:** nach JEDEC Level 2
- **Gurtung:** 8-mm Gurt mit 2000/Rolle, ø180 mm oder 8000/Rolle, ø330 mm

## Anwendungen

- optischer Indikator
- Hinterleuchtung (LCD, Handy, Schalter, Tasten, Displays, Werbebeleuchtung, Allgemeinbeleuchtung)
- Innenbeleuchtung im Automobilbereich (z.B. Instrumentenbeleuchtung u. ä.)

## Features

- **package:** white P-LCC-4 package, colorless clear resin
- **feature of the device:** extremely wide viewing angle; ideal for backlighting and coupling in light guides
- **wavelength:** 628 nm (super-red), 606 nm (orange), 570 nm (green)
- **viewing angle:** Lambertian Emitter (120°)
- **technology:** GaAIP
- **optical efficiency:** 1.5 lm/W (super-red, orange), 2.5 lm/W (green)
- **grouping parameter:** luminous intensity
- **assembly methods:** suitable for all SMT assembly methods
- **soldering methods:** IR reflow soldering and TTW soldering
- **preconditioning:** acc. to JEDEC Level 2
- **taping:** 8 mm Gurt mit 2000/reel, ø180 mm oder 8000/reel, ø330 mm

## Applications

- optical indicators
- backlighting (LCD, cellular phones, switches, keys, displays, illuminated advertising, general lighting)
- interior automotive lighting (e.g. dashboard backlighting)

**Bestellinformation**  
**Ordering Information**

Typ Type	Emissionsfarbe Color of Emission	Lichtstärke <sup>1)</sup> Seite 15 Luminous Intensity <sup>1)</sup> page 15	
		color 1	color 2
LOG T671	orange / green	2.8 ... 18.0	7.1 ... 18.0
LSG T671	super-red / green	4.5 ... 18.0	7.1 ... 28.0

**Bestellinformation**  
**Ordering Information**

Typ Type	Bestellnummer Ordering Code
LOG T671-HL-1+KL-1	Q62703Q4320
LSG T671-JL-1+KM-1	Q62703Q4321

**Grenzwerte**  
**Maximum Ratings**

Bezeichnung Parameter	Symbol Symbol	Wert Value	Einheit Unit
Betriebstemperatur Operating temperature range	$T_{op}$	- 40 ... + 100	°C
Lagertemperatur Storage temperature range	$T_{stg}$	- 40 ... + 100	°C
Sperrschichttemperatur Junction temperature	$T_j$	+ 100	°C
Durchlassstrom Forward current ( $T_A=25^\circ\text{C}$ )	$I_F$	30	mA
Stoßstrom Surge current $t \leq 10 \mu\text{s}$ , $D = 0.005$ , $T_A=25^\circ\text{C}$	$I_{FM}$	0.5	A
Sperrspannung <sup>2) Seite 15</sup> Reverse voltage <sup>2) page 15</sup> ( $T_A=25^\circ\text{C}$ )	$V_R$	12	V
Leistungsaufnahme Power consumption ( $T_A=25^\circ\text{C}$ )	$P_{tot}$	95	mW
Wärmewiderstand Thermal resistance			
Sperrschicht/Umgebung <sup>3) Seite 15</sup> Junction/ambient <sup>3) page 15</sup>	1 chip on $R_{th JA}$	480	K/W
	2 chips on $R_{th JA}$	650	K/W
Sperrschicht/Lötpad Junction/solder point	1 chip on $R_{th JS}$	260	K/W
	2 chips on $R_{th JS}$	360	K/W



**Kennwerte**  
**Characteristics**
 $(T_A = 25\text{ °C})$ 

Bezeichnung Parameter	Symbol Symbol	Werte Values			Einheit Unit
		super red	orange	green	
Wellenlänge des emittierten Lichtes (typ.) Wavelength at peak emission $I_F = 10\text{ mA}$	$\lambda_{\text{peak}}$	635	610	572	nm
Dominantwellenlänge <sup>4) Seite 15</sup> Dominant wavelength <sup>4) page 15</sup> $I_F = 10\text{ mA}$	$\lambda_{\text{dom}}$	628 $\pm 6$	606 $\pm 6$	570 $\pm 6$	nm
Spektrale Bandbreite bei 50 % $I_{\text{rel max}}$ (typ.) Spectral bandwidth at 50 % $I_{\text{rel max}}$ $I_F = 10\text{ mA}$	$\Delta\lambda$	45	40	25	nm
Abstrahlwinkel bei 50 % $I_V$ (Vollwinkel) (typ.) Viewing angle at 50 % $I_V$	$2\phi$	120	120	120	Grad deg.
Durchlassspannung <sup>5) Seite 15</sup> (typ.) Forward voltage <sup>5) page 15</sup> (max.) $I_F = 10\text{ mA}$	$V_F$ $V_F$	2.0 2.5	2.0 2.5	2.0 2.5	V V
Sperrstrom (typ.) Reverse current (max.) $V_R = 12\text{ V}$	$I_R$ $I_R$	0.01 10	0.01 10	0.01 10	$\mu\text{A}$ $\mu\text{A}$
Temperaturkoeffizient von $\lambda_{\text{peak}}$ (typ.) Temperature coefficient of $\lambda_{\text{peak}}$ $I_F = 10\text{ mA}; -10\text{ °C} \leq T \leq 100\text{ °C}$	$TC_{\lambda_{\text{peak}}}$	0.11	0.12	0.11	nm/K
Temperaturkoeffizient von $\lambda_{\text{dom}}$ (typ.) Temperature coefficient of $\lambda_{\text{dom}}$ $I_F = 10\text{ mA}; -10\text{ °C} \leq T \leq 100\text{ °C}$	$TC_{\lambda_{\text{dom}}}$	0.07	0.07	0.07	nm/K
Temperaturkoeffizient von $V_F$ (typ.) Temperature coefficient of $V_F$ $I_F = 10\text{ mA}; -10\text{ °C} \leq T \leq 100\text{ °C}$	$TC_V$	-1.9	-1.9	-1.4	mV/K
Optischer Wirkungsgrad (typ.) Optical efficiency $I_F = 10\text{ mA}$	$\eta_{\text{opt}}$	1.5	1.5	2.5	lm/W

## Helligkeits-Gruppierungsschema Brightness Groups

Helligkeitsgruppe Brightness Group	Lichtstärke <sup>1)</sup> Seite 15 Luminous Intensity <sup>1)</sup> page 15	Lichtstrom <sup>6)</sup> Seite 15 Luminous Flux <sup>6)</sup> page 15
	$I_V$ (mcd)	$\Phi_V$ (lm)
H	2.8 ... 4.5	11 (typ.)
J	4.5 ... 7.1	17 (typ.)
K	7.1 ... 11.2	27 (typ.)
L	11.2 ... 18.0	35 (typ.)
M	18.0 ... 28.0	68 (typ.)

Anm.: Die Standardlieferform von Serientypen beinhaltet eine Familiengruppe. Einzelne Helligkeitsgruppen sind nicht bestellbar.

Note: The standard shipping format for serial types includes a family group. Individual brightness groups cannot be ordered.

## Gruppenbezeichnung auf Etikett

### Group Name on Label

Beispiel: J-1+M-1

Example: J-1+M-1

Helligkeitsgruppe Brightness Group	Wellenlänge (keine Gruppierung) Wavelength (no grouping)	Helligkeitsgruppe Brightness Group	Wellenlänge (keine Gruppierung) Wavelength (no grouping)
(super-red)	(super-red)	(green)	(green)
J	1	M	1

Anm.: In einer Verpackungseinheit / Gurt ist immer nur eine Helligkeitsgruppe pro Farbe enthalten.

Note: No packing unit / tape ever contains more than one brightness group per color.

## Gruppenbezeichnung auf Etikett

### Group Name on Label

Beispiel: H-1+K-1

Example: H-1+K-1

Helligkeitsgruppe Brightness Group	Wellenlänge (keine Gruppierung) Wavelength (no grouping)	Helligkeitsgruppe Brightness Group	Wellenlänge (keine Gruppierung) Wavelength (no grouping)
(orange)	(orange)	(green)	(green)
H	1	K	1

Anm.: In einer Verpackungseinheit / Gurt ist immer nur eine Helligkeitsgruppe pro Farbe enthalten.

Note: No packing unit / tape ever contains more than one brightness group per color.

**Relative spektrale Emission**<sup>6)</sup> Seite 15

**Relative Spectral Emission**<sup>6)</sup> page 15

$V(\lambda)$  = spektrale Augenempfindlichkeit / Standard eye response curve

$I_{rel} = f(\lambda)$ ;  $T_A = 25\text{ °C}$ ;  $I_F = 10\text{ mA}$

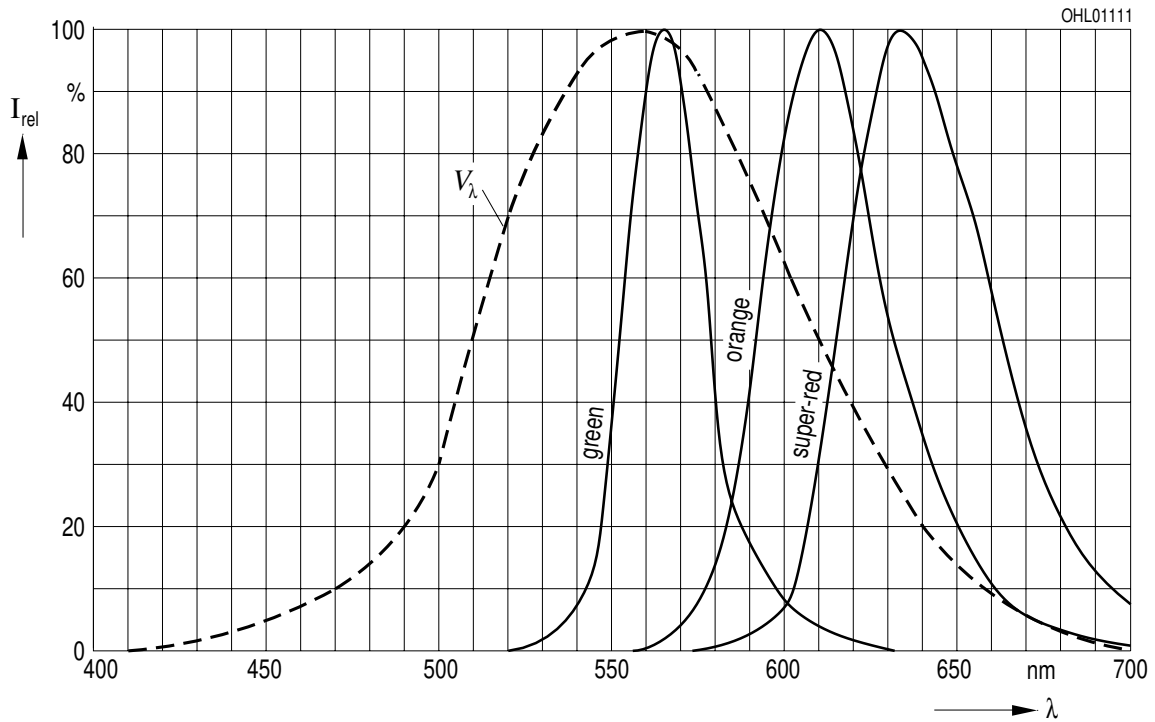

**Abstrahlcharakteristik**<sup>6)</sup> Seite 15

**Radiation Characteristic**<sup>6)</sup> page 15

$I_{rel} = f(\varphi)$ ;  $T_A = 25\text{ °C}$

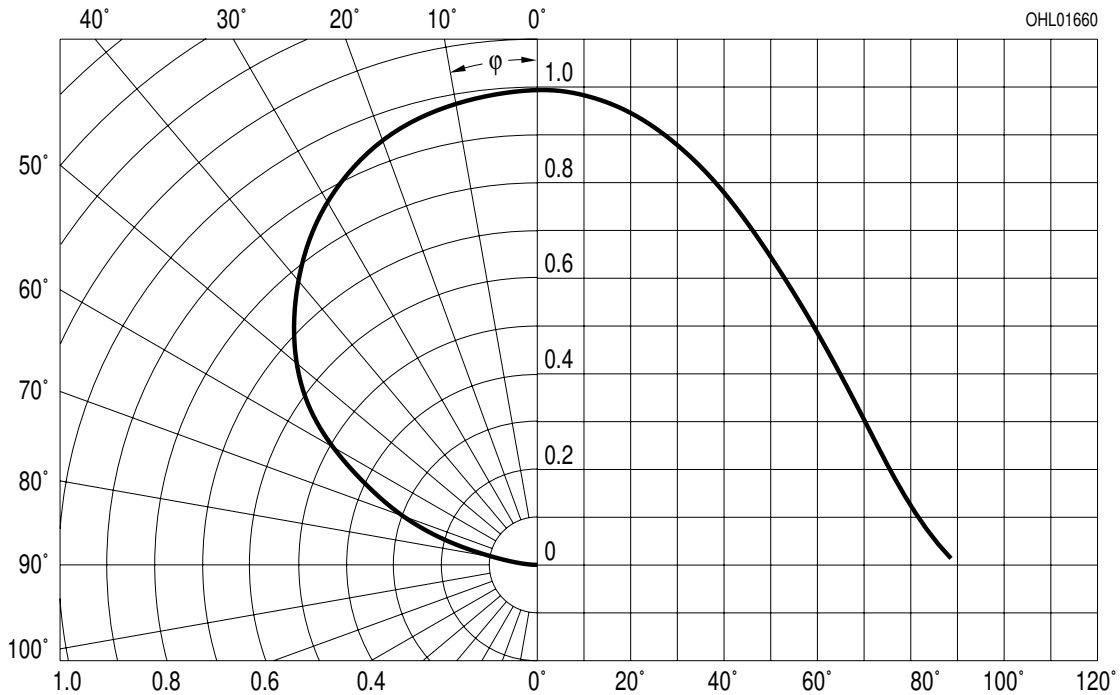

**Durchlassstrom**<sup>6) 7) Seite 15</sup>  
**Forward Current**<sup>6) 7) page 15</sup>

$I_F = f(V_F); T_A = 25\text{ °C}$

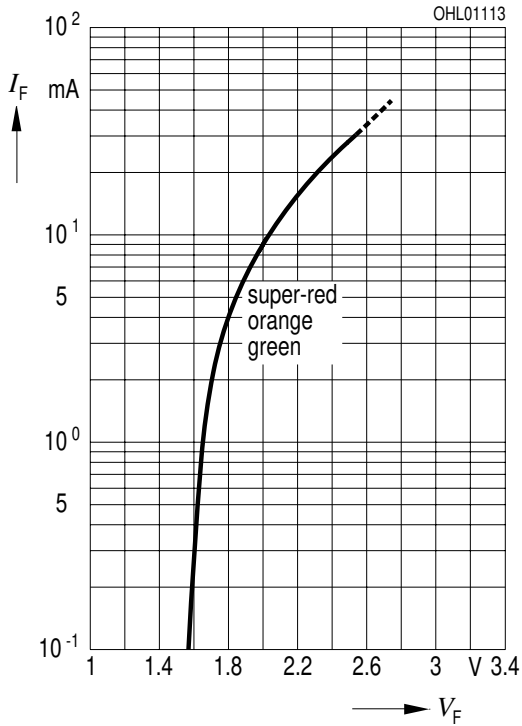

**Relative Lichtstärke**<sup>6) 7) Seite 15</sup>

**Relative Luminous Intensity**<sup>6) 7) page 15</sup>

$I_V/I_{V(10\text{ mA})} = f(I_F); T_A = 25\text{ °C}$

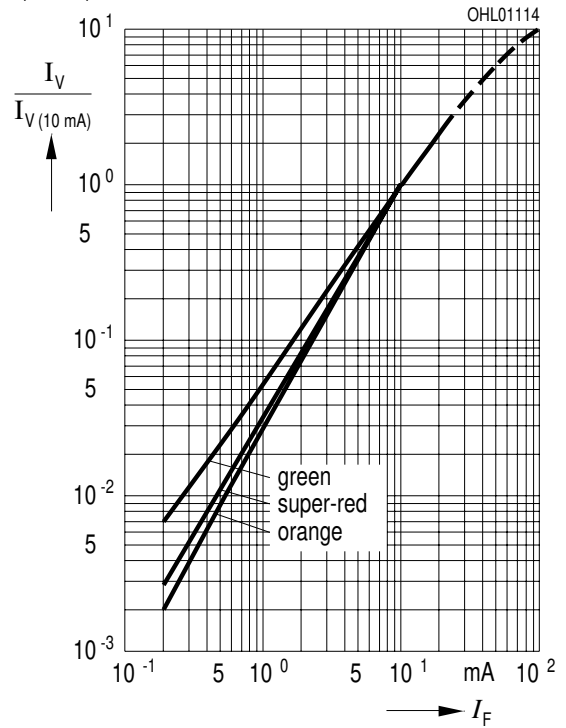

**Relative Lichtstärke**<sup>6) Seite 15</sup>

**Relative Luminous Intensity**<sup>6) page 15</sup>

$I_V/I_{V(25\text{ °C})} = f(T_j); I_F = 10\text{ mA}$

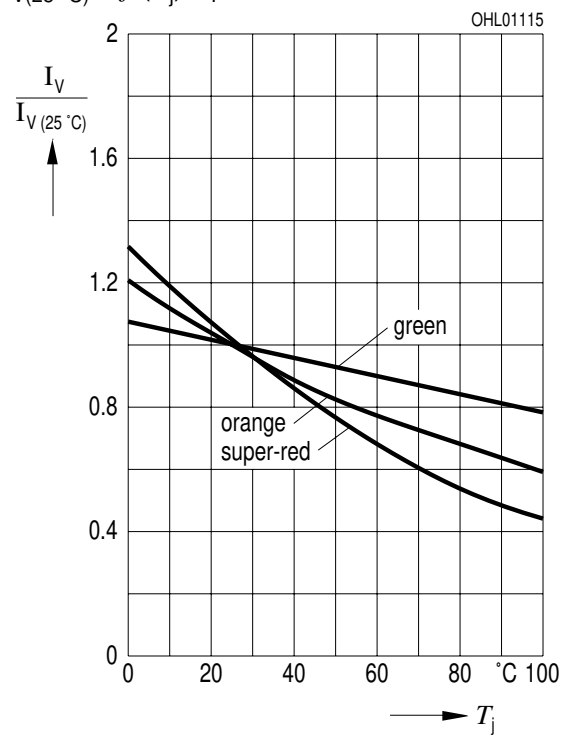



**Maximal zulässiger Durchlassstrom**  
**Max. Permissible Forward Current**

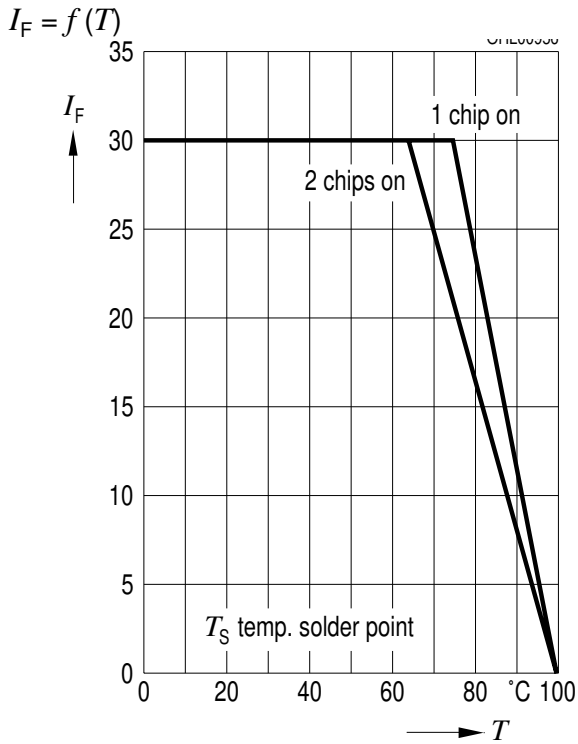

**Maximal zulässiger Durchlassstrom**  
**Max. Permissible Forward Current**

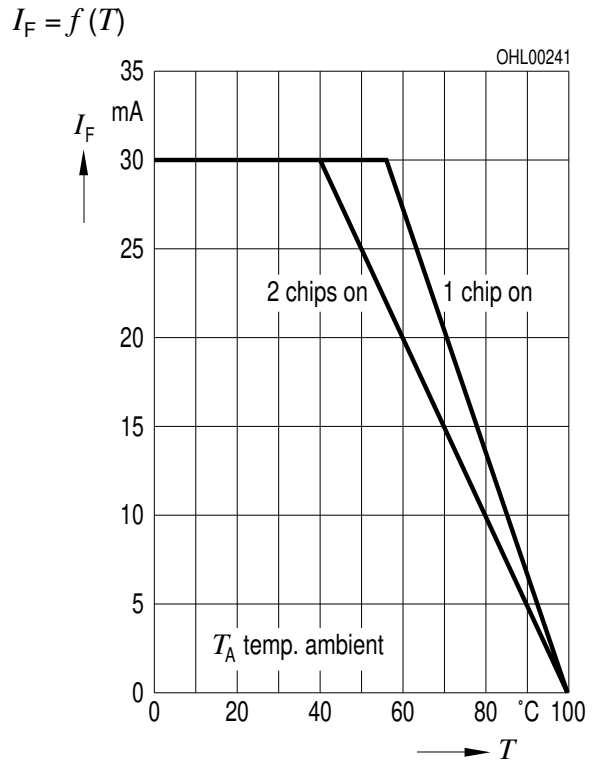

**Zulässige Impulsbelastbarkeit**  $I_F = f(t_p)$   
**Permissible Pulse Handling Capability**  
 Duty cycle  $D =$  parameter,  $T_A = 25\text{ °C}$

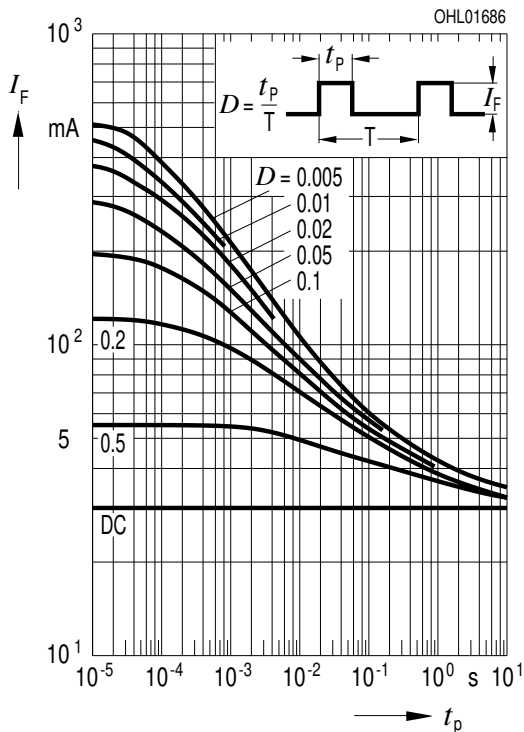

Maßzeichnung<sup>8)</sup> Seite 15  
 Package Outlines<sup>8)</sup> page 15

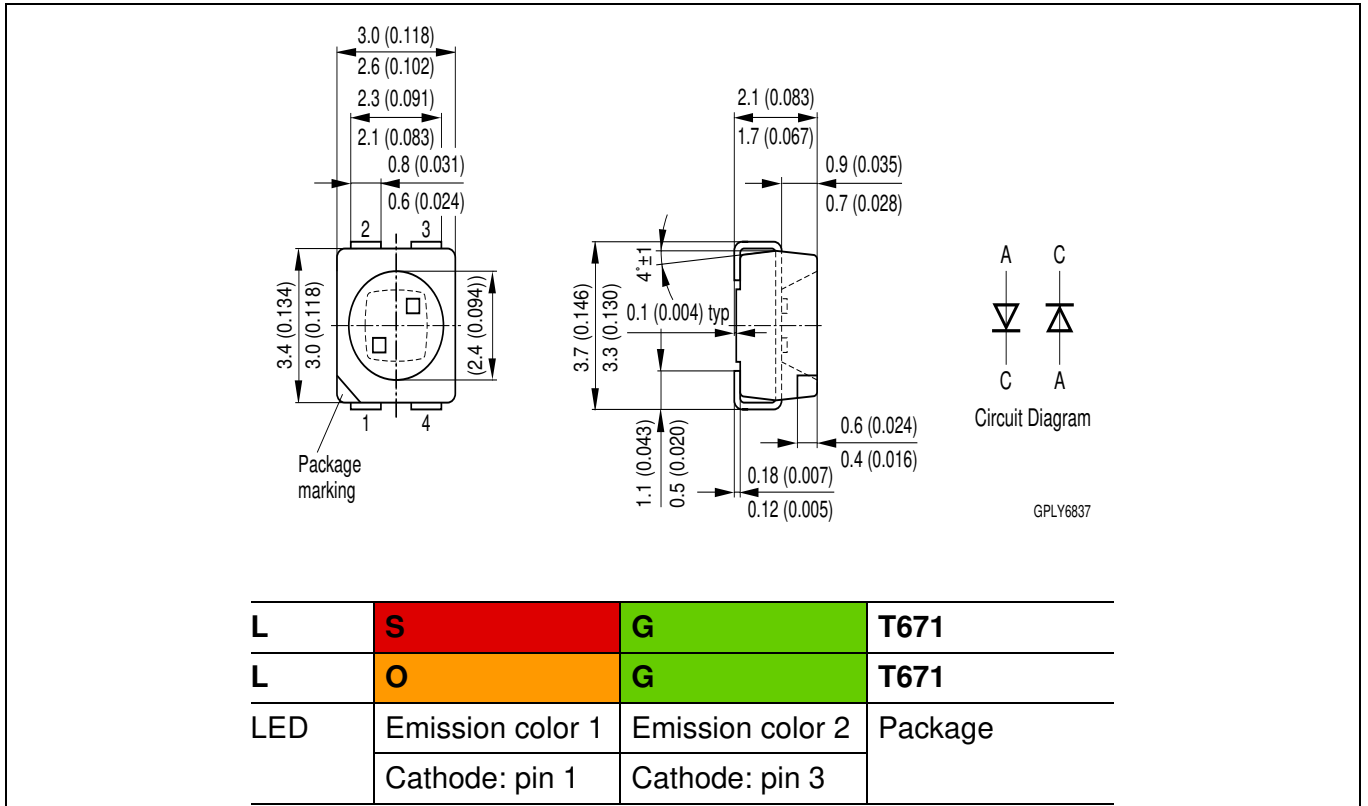

**Kathodenkennung:** abgeschrägte Ecke  
**Cathode mark:** bevelled edge  
**Gewicht / Approx. weight:** 35 mg

**Gurtung / Polarität und Lage<sup>8)</sup> Seite 15** Verpackungseinheit 2000/Rolle, ø180 mm  
 oder 8000/Rolle, ø330 mm

**Method of Taping / Polarity and Orientation<sup>8)</sup> page 15** Packing unit 2000/reel, ø180 mm  
 or 8000/reel, ø330 mm

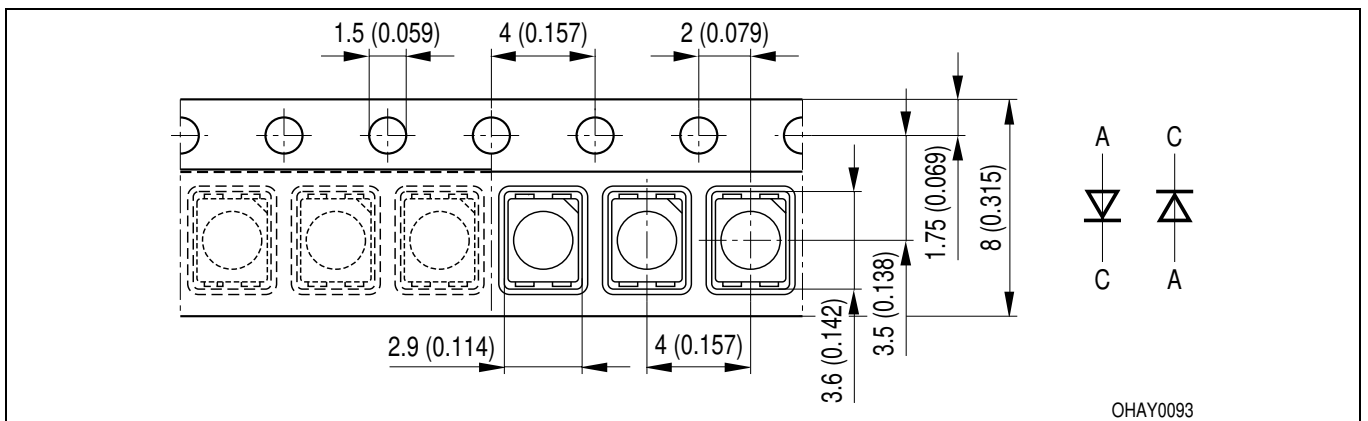

**Empfohlenes Lötpad Design<sup>8)</sup> Seite 15**  
**Recommended Solder Pad<sup>8)</sup> page 15**

**IR Reflow Löten**  
**IR Reflow Soldering**

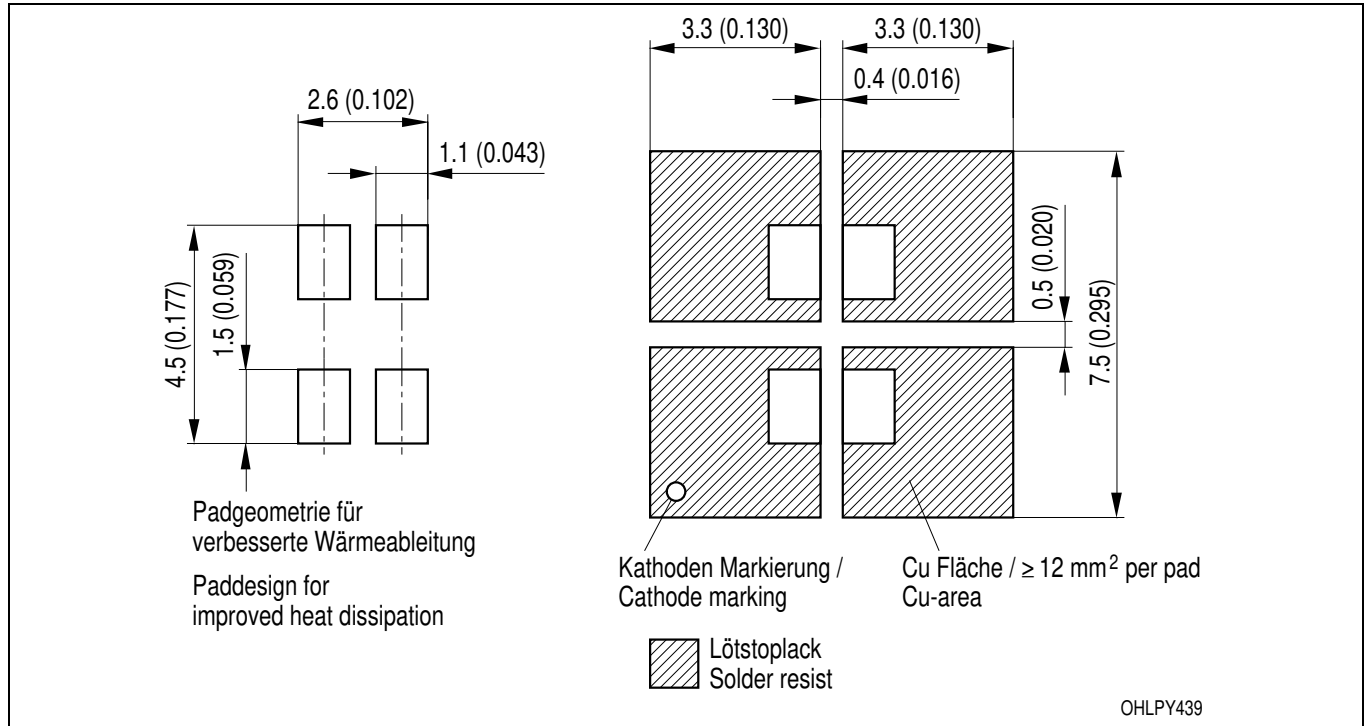

**Empfohlenes Lötpad Design<sup>8)</sup> Seite 15**  
**Recommended Solder Pad<sup>8)</sup> page 15**

**Wellenlöten (TTW)**  
**TTW Soldering**

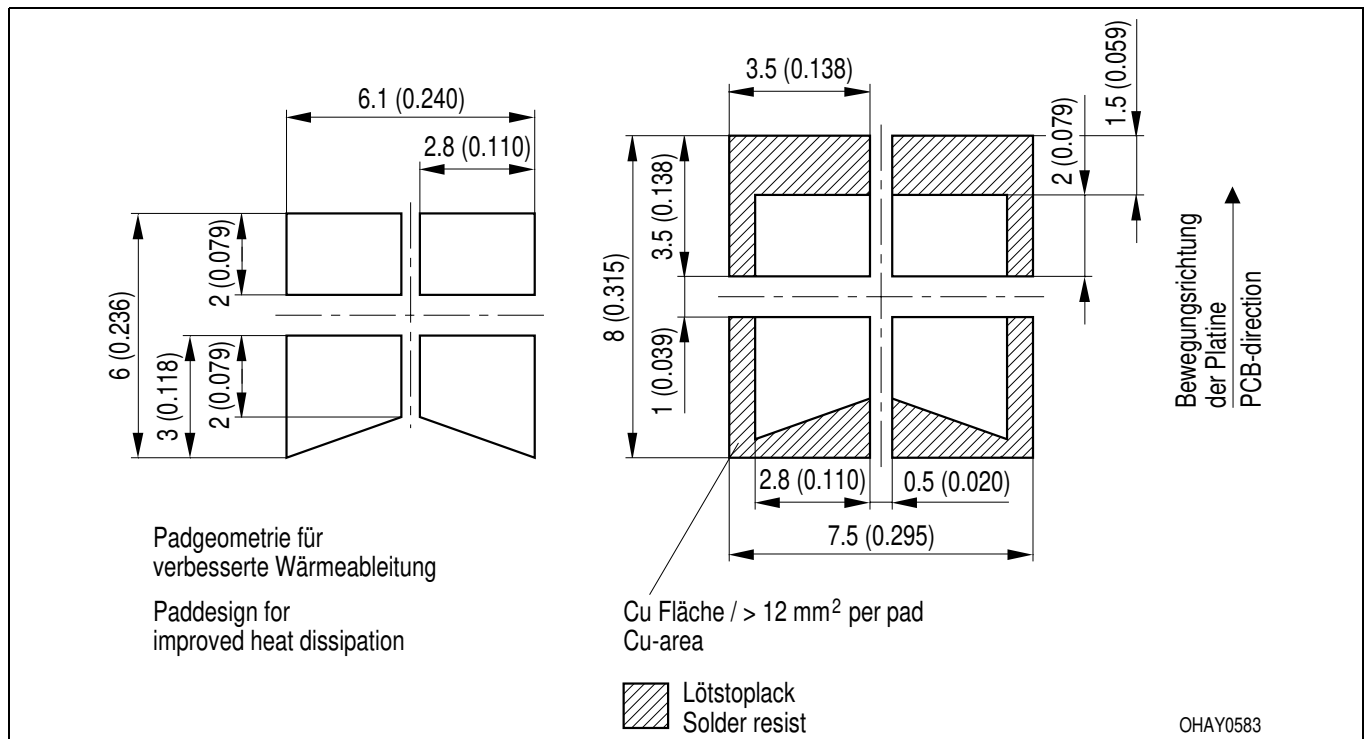

**Lötbedingungen**  
**Soldering Conditions**

Vorbehandlung nach JEDEC Level 2  
Preconditioning acc. to JEDEC Level 2

**IR-Reflow Lötprofil**  
**IR Reflow Soldering Profile**

(nach IPC 9501)  
(acc. to IPC 9501)

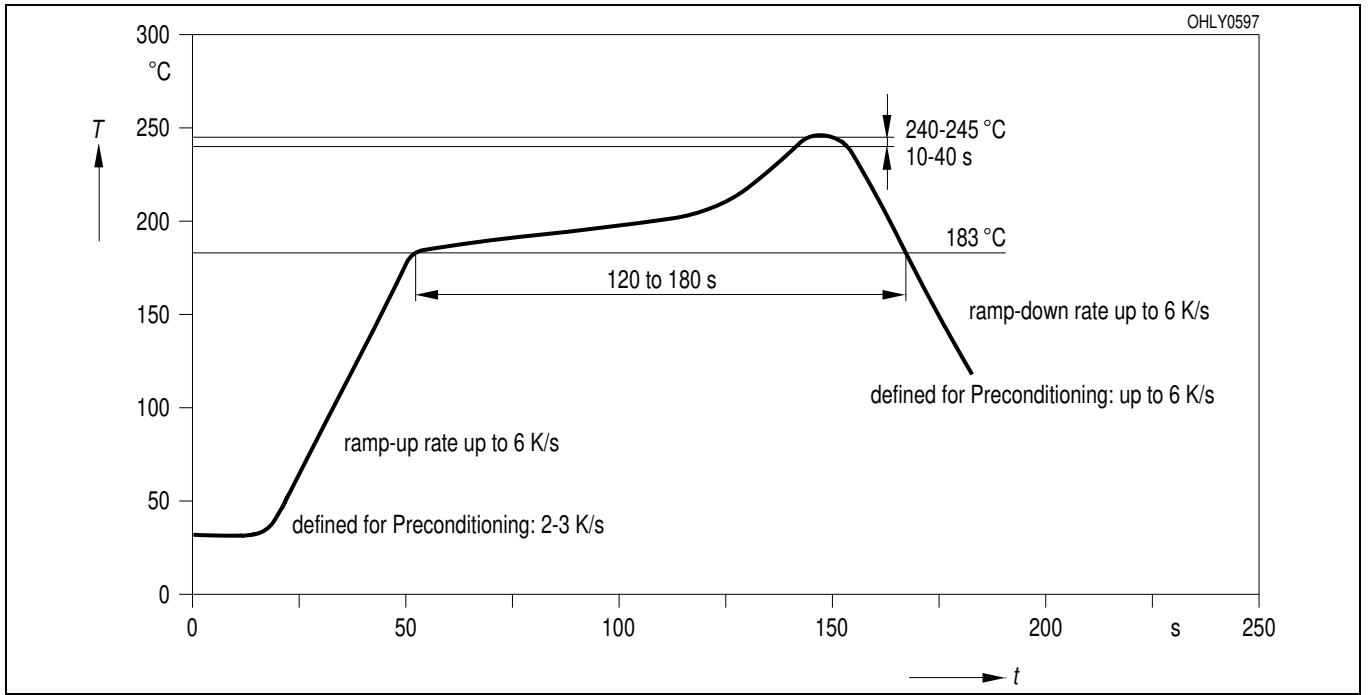

**Wellenlöten (TTW)**  
**TTW Soldering**

(nach CECC 00802)  
(acc. to CECC 00802)

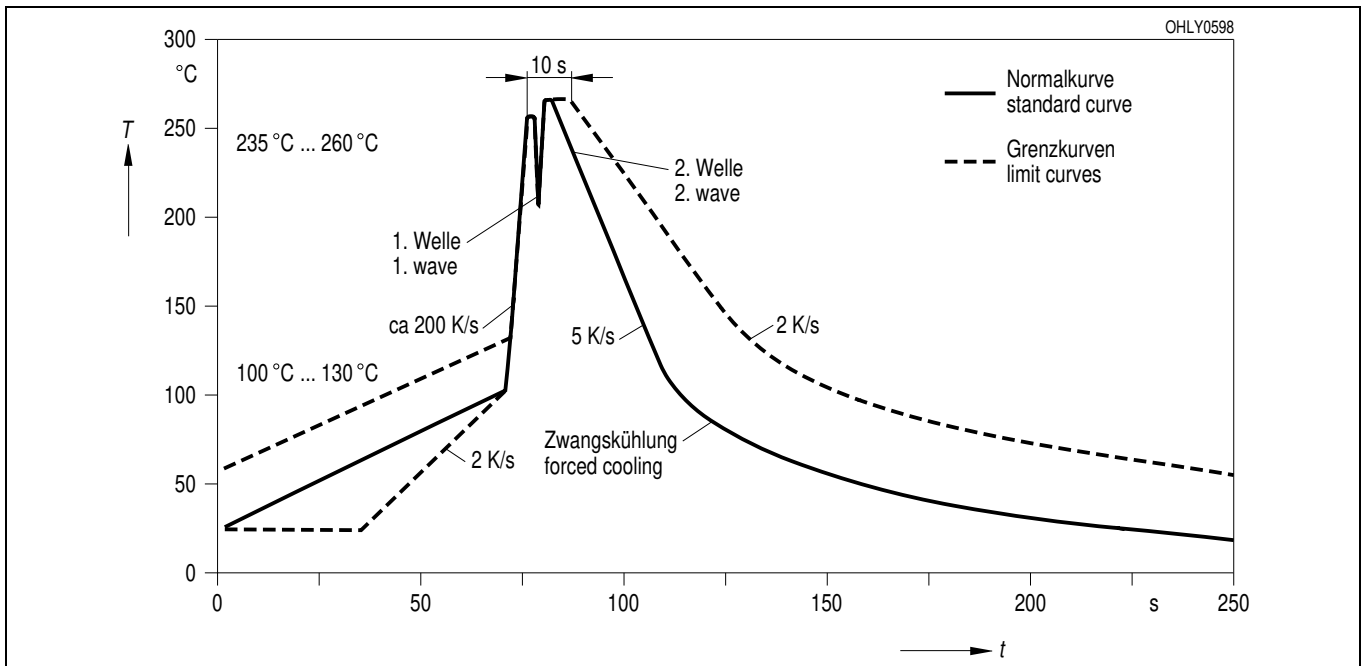

**Barcode-Produkt-Etikett (BPL)**  
**Barcode-Product-Label (BPL)**

**OSRAM Opto Semiconductors**

Lx xxxx Bin1: Bin Information Color 1  
 Product Name Bin2:  
 Bin3:

(6P) BATCH NO: Batch Number  
**Bar Code**

(1T) LOT NO: Lot Number (9D) D/C: Date Code  
**Bar Code**

(X) PROD NO: Product Code (Q) QTY: Product Quantity per Reel (G) GROUP: X - X - X  
**Bar Code**

ML Temp ST  
 2 245 C R  
 2 260 C T

Additional TEXT  
 R077 DEMY  
 PACKVAR: Packing Type

Forward Voltage Rank  
 Wavelength Rank  
 Brightness Rank

OHA02043

**Gurtverpackung**  
**Tape and Reel**

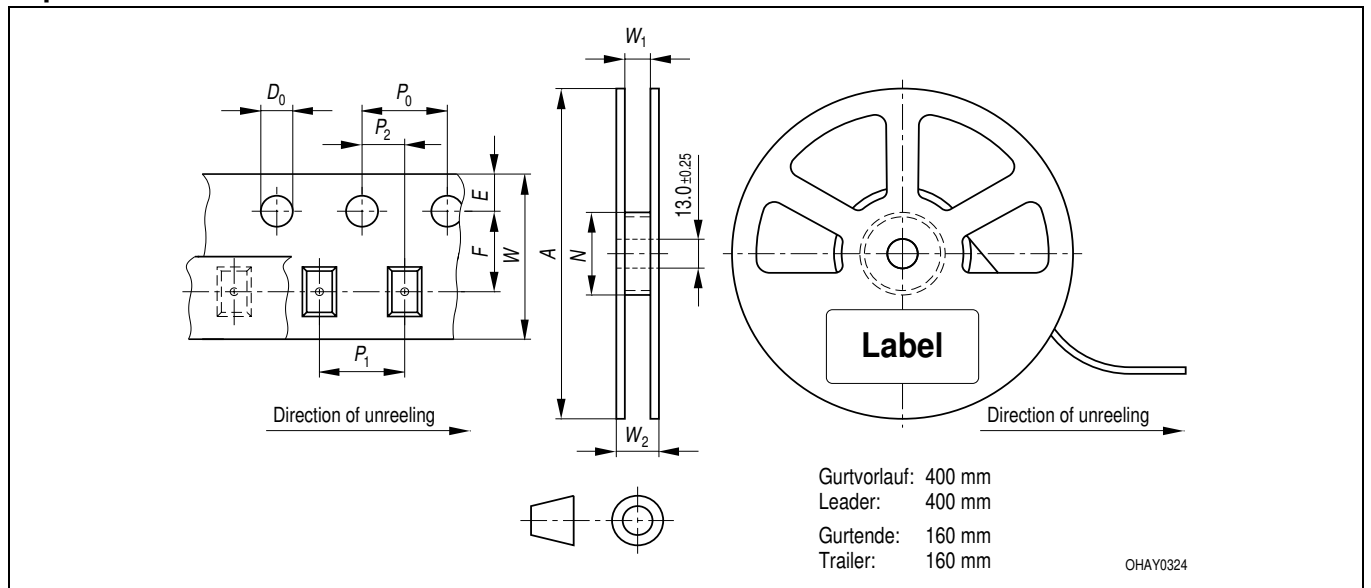

Tape dimensions in mm (inch)

W	P <sub>0</sub>	P <sub>1</sub>	P <sub>2</sub>	D <sub>0</sub>	E	F
8 <sup>+0.3</sup> -0.1	4 ± 0.1 (0.157 ± 0.004)	4 ± 0.1 (0.157 ± 0.004)	2 ± 0.05 (0.079 ± 0.002)	1.5 ± 0.1 (0.059 ± 0.004)	1.75 ± 0.1 (0.069 ± 0.004)	3.5 ± 0.05 (0.138 ± 0.002)

Reel dimensions in mm (inch)

A	W	N <sub>min</sub>	W <sub>1</sub>	W <sub>2 max</sub>
180 (7)	8 (0.315)	60 (2.362)	8.4 + 2 (0.331 + 0.079)	14.4 (0.567)
330 (13)	8 (0.315)	60 (2.362)	8.4 + 2 (0.331 + 0.079)	14.4 (0.567)

## Trockenverpackung und Materialien Dry Packing Process and Materials

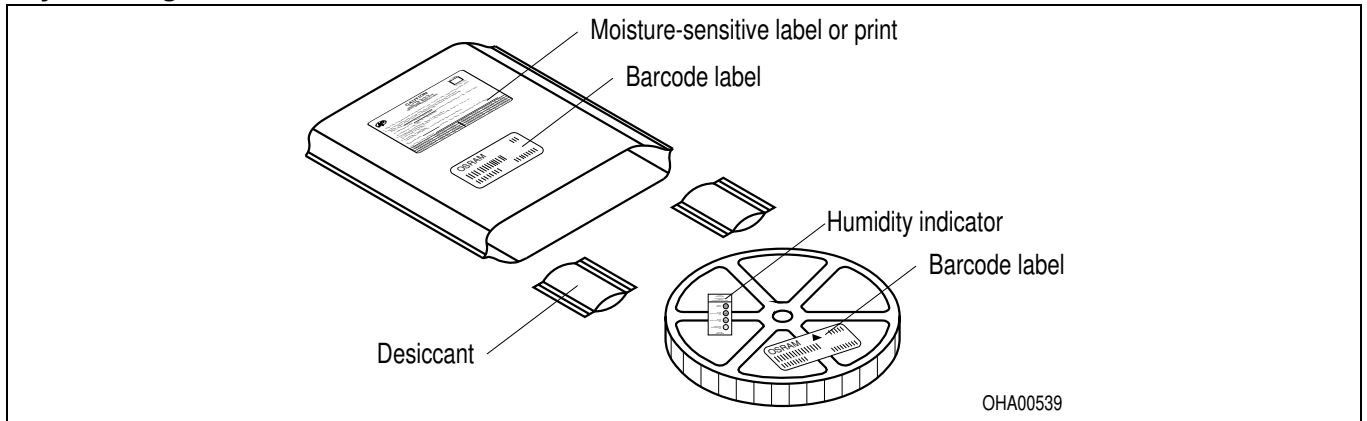

Anm.: Feuchteempfindliche Produkte sind verpackt in einem Trockenbeutel zusammen mit einem Trockenmittel und einer Feuchteindikatorkarte

Bezüglich Trockenverpackung finden Sie weitere Hinweise im Internet und in unserem Short Form Catalog im Kapitel "Gurtung und Verpackung" unter dem Punkt "Trockenverpackung". Hier sind Normenbezüge, unter anderem ein Auszug der JEDEC-Norm, enthalten.

Note: Moisture-sensitive product is packed in a dry bag containing desiccant and a humidity card.

Regarding dry pack you will find further information in the internet and in the Short Form Catalog in chapter "Tape and Reel" under the topic "Dry Pack". Here you will also find the normative references like JEDEC.

## Kartonverpackung und Materialien Transportation Packing and Materials

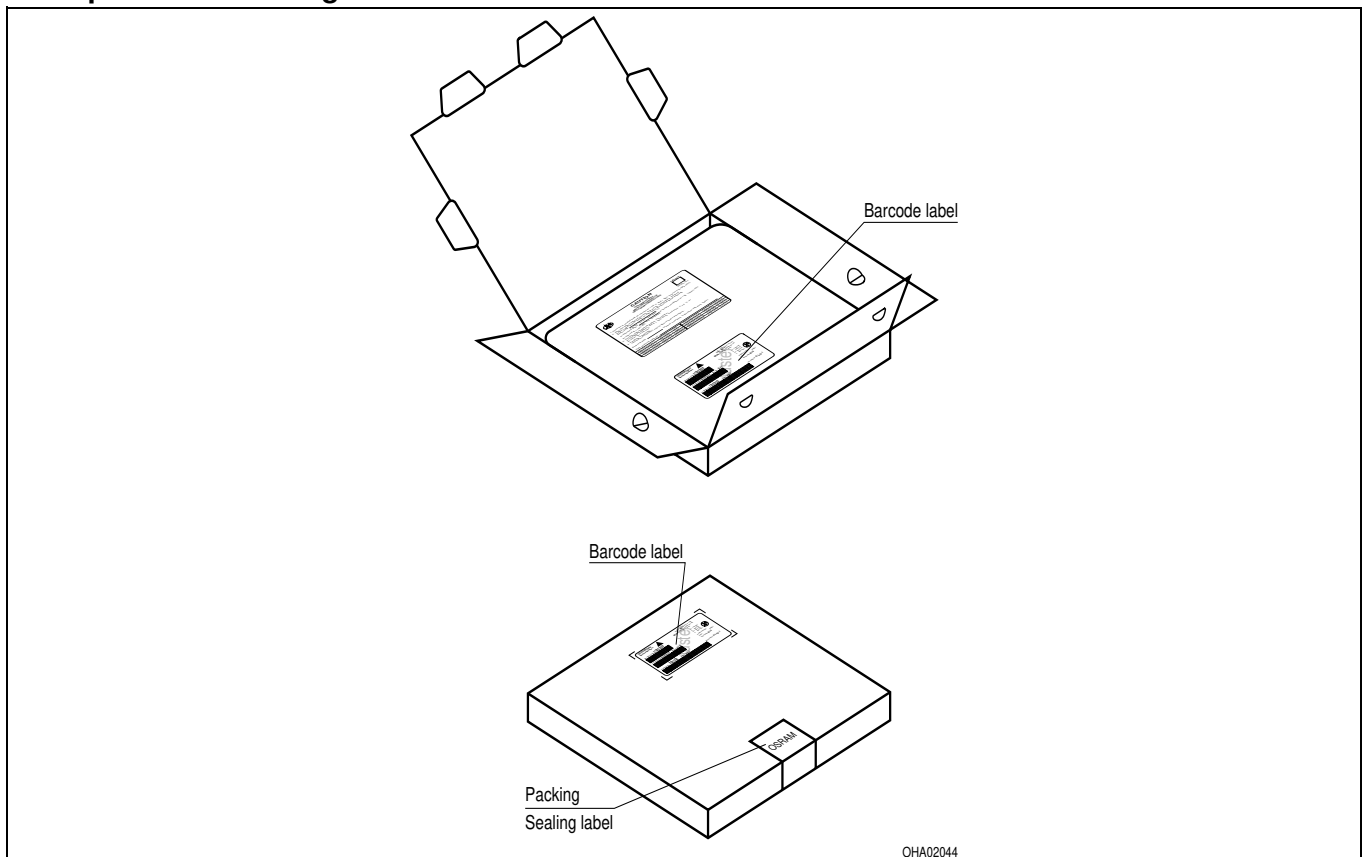



**Revision History: 2005-04-05**

Previous Version: 2004-08-13

Page	Subjects (major changes since last revision)	Date of change
13	annotations	2002-07-23
3, 4	value (reverse voltage from 5 V to 12 V)	2002-09-18
3	ambient temperature	2003-09-09
all	new template	2004-03-11
all	Discontinuation of non-RoHS compliant product versions	2005-04-05

**Attention please!**

The information describes the type of component and shall not be considered as assured characteristics. Terms of delivery and rights to change design reserved. Due to technical requirements components may contain dangerous substances. For information on the types in question please contact our Sales Organization. If printed or downloaded, please find the latest version in the Internet.

**Packing**

Please use the recycling operators known to you. We can also help you – get in touch with your nearest sales office. By agreement we will take packing material back, if it is sorted. You must bear the costs of transport. For packing material that is returned to us unsorted or which we are not obliged to accept, we shall have to invoice you for any costs incurred.

**Components used in life-support devices or systems must be expressly authorized for such purpose!** Critical components<sup>9) page 15</sup> may only be used in life-support devices or systems<sup>10) page 15</sup> with the express written approval of OSRAM OS.

**Fußnoten:**

- 1) Helligkeitswerte werden mit einer Stromeinprägedauer von 25 ms und einer Genauigkeit von  $\pm 11\%$  ermittelt.
- 2) Die LED kann kurzzeitig in Sperrichtung betrieben werden.
- 3)  $R_{thJA}$  ergibt sich bei Montage auf PC-Board FR 4 (Padgröße  $\geq 16 \text{ mm}^2$  je Pad)
- 4) Wellenlängen werden mit einer Stromeinprägedauer von 25 ms und einer Genauigkeit von  $\pm 1 \text{ nm}$  ermittelt.
- 5) Spannungswerte werden mit einer Stromeinprägedauer von 1 ms und einer Genauigkeit von  $\pm 0,1 \text{ V}$  ermittelt.
- 6) Wegen der besonderen Prozessbedingungen bei der Herstellung von LED können typische oder abgeleitete technische Parameter nur aufgrund statistischer Werte wiedergegeben werden. Diese stimmen nicht notwendigerweise mit den Werten jedes einzelnen Produktes überein, dessen Werte sich von typischen und abgeleiteten Werten oder typischen Kennlinien unterscheiden können. Falls erforderlich, z.B. aufgrund technischer Verbesserungen, werden diese typischen Werte ohne weitere Ankündigung geändert.
- 7) Im gestrichelten Bereich der Kennlinien muss mit erhöhten Helligkeitsunterschieden zwischen Leuchtdioden innerhalb einer Verpackungseinheit gerechnet werden.  
Dimmverhältnis im Gleichstrom-Betrieb max. 5:1 für amber
- 8) Maße werden wie folgt angegeben: mm (inch)
- 9) Ein kritisches Bauteil ist ein Bauteil, das in lebenserhaltenden Apparaten oder Systemen eingesetzt wird und dessen Defekt voraussichtlich zu einer Fehlfunktion dieses lebenserhaltenden Apparates oder Systems führen wird oder die Sicherheit oder Effektivität dieses Apparates oder Systems beeinträchtigt.
- 10) Lebenserhaltende Apparate oder Systeme sind für
  - (a) die Implantierung in den menschlichen Körper oder
  - (b) für die Lebenserhaltung bestimmt.
 Falls sie versagen, kann davon ausgegangen werden, dass die Gesundheit und das Leben des Patienten in Gefahr ist.

**Remarks:**

- 1) Brightness groups are tested at a current pulse duration of 25 ms and a tolerance of  $\pm 11\%$ .
- 2) Driving the LED in reverse direction is suitable for short term application.
- 3)  $R_{thJA}$  results from mounting on PC board FR 4 (pad size  $\geq 16 \text{ mm}^2$  per pad)
- 4) Wavelengths are tested at a current pulse duration of 25 ms and a tolerance of  $\pm 1 \text{ nm}$ .
- 5) Forward voltages are tested at a current pulse duration of 1 ms and a tolerance of  $\pm 0.1 \text{ V}$ .
- 6) Due to the special conditions of the manufacturing processes of LED, the typical data or calculated correlations of technical parameters can only reflect statistical figures. These do not necessarily correspond to the actual parameters of each single product, which could differ from the typical data and calculated correlations or the typical characteristic line. If requested, e.g. because of technical improvements, these typ. data will be changed without any further notice.
- 7) In the range where the line of the graph is broken, you must expect higher brightness differences between single LEDs within one packing unit.  
Dimming range for direct current mode max. 5:1 for amber
- 8) Dimensions are specified as follows: mm (inch)
- 9) A critical component is a component used in a life-support device or system whose failure can reasonably be expected to cause the failure of that life-support device or system, or to affect its safety or the effectiveness of that device or system.
- 10) Life support devices or systems are intended
  - (a) to be implanted in the human body,
  - or
  - (b) to support and/or maintain and sustain human life.
 If they fail, it is reasonable to assume that the health and the life of the user may be endangered.