



Chipsmall Limited consists of a professional team with an average of over 10 year of expertise in the distribution of electronic components. Based in Hongkong, we have already established firm and mutual-benefit business relationships with customers from,Europe,America and south Asia,supplying obsolete and hard-to-find components to meet their specific needs.

With the principle of “Quality Parts,Customers Priority,Honest Operation,and Considerate Service”,our business mainly focus on the distribution of electronic components. Line cards we deal with include Microchip,ALPS,ROHM,Xilinx,Pulse,ON,Everlight and Freescale. Main products comprise IC,Modules,Potentiometer,IC Socket,Relay,Connector.Our parts cover such applications as commercial,industrial, and automotives areas.

We are looking forward to setting up business relationship with you and hope to provide you with the best service and solution. Let us make a better world for our industry!



Contact us

Tel: +86-755-8981 8866 Fax: +86-755-8427 6832

Email & Skype: info@chipsmall.com Web: www.chipsmall.com

Address: A1208, Overseas Decoration Building, #122 Zhenhua RD., Futian, Shenzhen, China



REV.	DESCRIPTION	DATE	APPROVED
F	Production Release	02/27/04	M. C.
G	Added Notes 4, 5, 6 & Color Options Sheet #2	05/16/16	J. C.

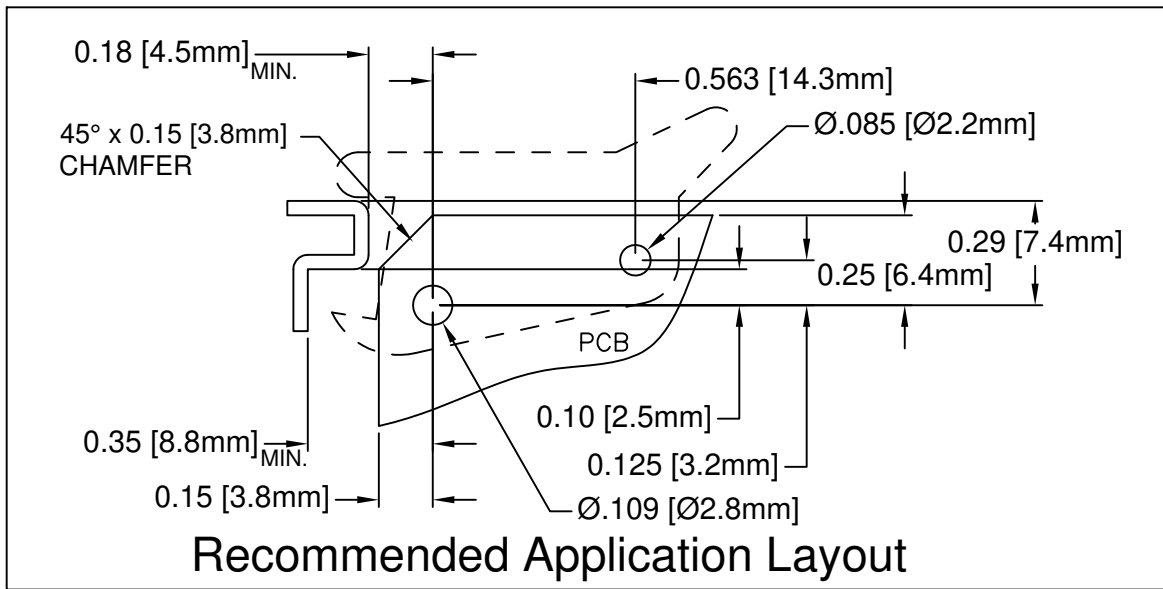
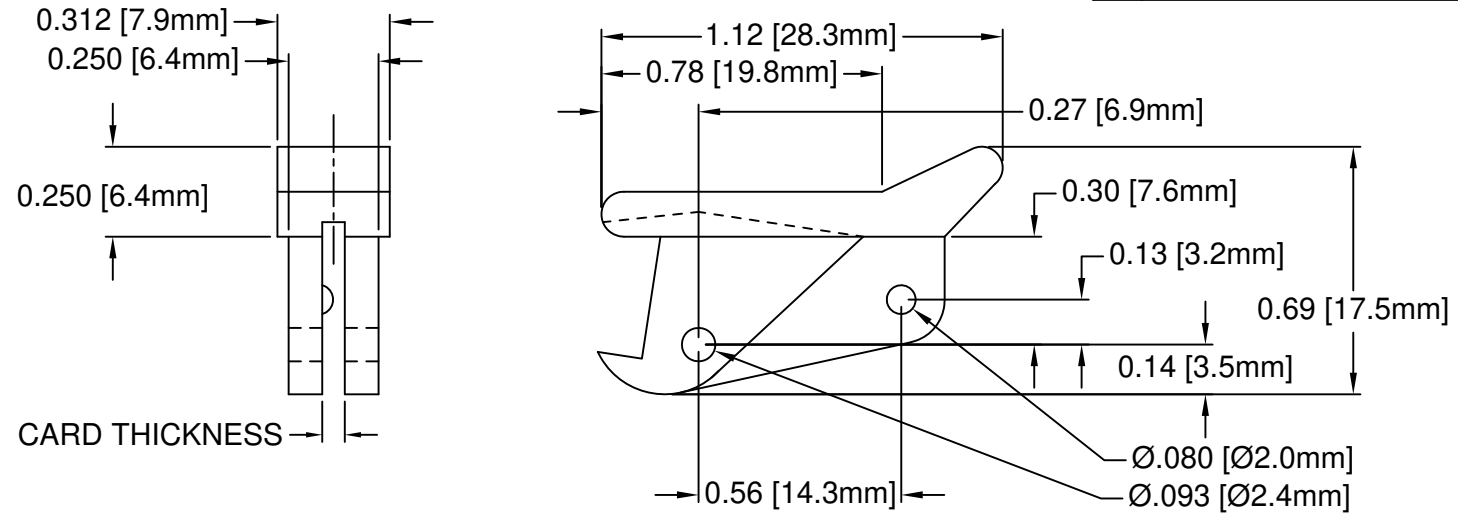

PART NO.	COLOR	ROLL PIN	CARD THICKNESS
LP-06 NT	NATURAL	RP-250	1/16" (1.6mm)
LP-06 WE	WHITE	RP-250	
LP-06 XX	SEE S.#2	RP-250	

Recommended Application Layout

5. PRE-ASSEMBLED ROLL PINS AVAILABLE UPON REQUEST.
4. ROLL PINS INCLUDED. PACKAGED SEPARATELY.
3. MATERIAL: NYLON 6/6, 94V-2, WHITE.
2. MATERIAL: NYLON 6/6, 94V-2, NATURAL.
1. GENERAL SPECIFICATIONS: BIVAR MOLDED COMPONENT SPECIFICATION BV00-E101.

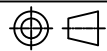
STANDARD TOLERANCE (UNLESS OTHERWISE SPECIFIED)		 4 THOMAS, IRVINE, CA. 92618 TEL.: (949) 951-8808 FAX: (949) 951-3974	
DECIMALS	ANGULAR		
.X ± .1	X° ± 1°	 TITLE: CIRCUIT BOARD CARD EJECTOR	
.XX ± .01			
.XXX ± .005		PART NO: LP-06	
DESIGNED: S. Irving	DATE: 09/21/98	REVISION: G	
CHECKED: R. Dienst	DATE: 04/06/00	CAGE CODE : 32559 SHEET # 1 OF 2	
CAD GENERATED DOCUMENT. DO NOT MEASURE DRAWING.			

OTHER AVAILABLE COLORS

* SEE TABLE FOR ORDERING INFORMATION

REV.	DESCRIPTION	DATE	APPROVED
	SEE SHEET #1		

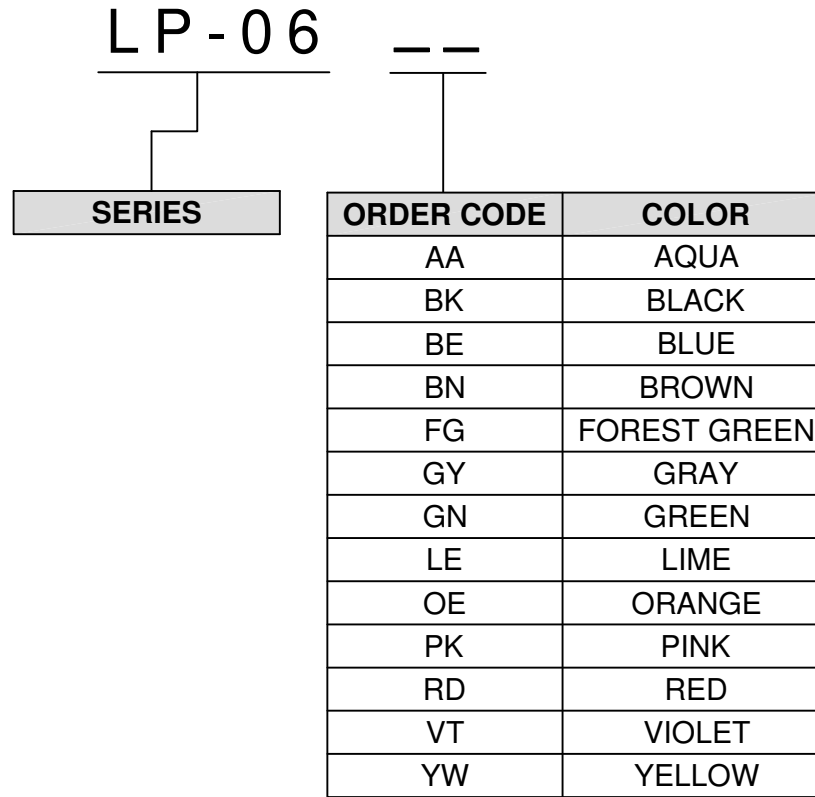

6. PARTS ARE DYED TO COLOR UPON REQUEST.

STANDARD TOLERANCE (UNLESS OTHERWISE SPECIFIED) <small>DECIMALS ANGULAR</small>		BIVAR [®] 4 THOMAS, IRVINE, CA. 92618 <small>TEL.: (949) 951-8808 FAX: (949) 951-3974</small>	
DESIGNED: S. Irving		<div style="display: flex; align-items: center;"> TITLE: CIRCUIT BOARD CARD EJECTOR </div>	
DATE: 09/21/98		PART NO: LP-06	REVISION: G
CHECKED: R. Dienst		DATE: 04/06/00	
CAGE CODE : 32559		SHEET # 2 OF 2	
<small>CAD GENERATED DOCUMENT. DO NOT MEASURE DRAWING.</small>			