



Chipsmall Limited consists of a professional team with an average of over 10 year of expertise in the distribution of electronic components. Based in Hongkong, we have already established firm and mutual-benefit business relationships with customers from,Europe,America and south Asia,supplying obsolete and hard-to-find components to meet their specific needs.

With the principle of "Quality Parts,Customers Priority,Honest Operation,and Considerate Service",our business mainly focus on the distribution of electronic components. Line cards we deal with include Microchip,ALPS,ROHM,Xilinx,Pulse,ON,Everlight and Freescale. Main products comprise IC,Modules,Potentiometer,IC Socket,Relay,Connector.Our parts cover such applications as commercial,industrial, and automotives areas.

We are looking forward to setting up business relationship with you and hope to provide you with the best service and solution. Let us make a better world for our industry!



Contact us

Tel: +86-755-8981 8866 Fax: +86-755-8427 6832

Email & Skype: info@chipsmall.com Web: www.chipsmall.com

Address: A1208, Overseas Decoration Building, #122 Zhenhua RD., Futian, Shenzhen, China



Type LPW 85 °C Snap-In Aluminum Electrolytic Capacitors

Low Voltage, High Value Capacitors



Type LPW radial leaded snap-in aluminum electrolytic capacitors are a compact design for high density packaging and is ideal for low voltage, general purpose input filtering applications.

Highlights

- Low voltage
- High Capacitance
- 85 °C
- Good for input filtering in consumer applications
- 22 to 35 mm diameter with 10 mm lead spacing

Specifications



Complies with the EU Directive 2002/95/EC requirement restricting the use of Lead (Pb), Mercury (Hg), Cadmium (Cd), Hexavalent chromium (Cr(VI)), PolyBrominated Biphenyls (PBB) and PolyBrominated Diphenyl Ethers (PBDE).

Capacitance Range: 820 to 22,000 μF
Voltage Range: 10 to 100 Vdc
Capacitance tolerance: $\pm 20\%$
Operating Temperature Range: $-40\text{ }^\circ\text{C}$ to $+85\text{ }^\circ\text{C}$
Dissipation Factor

DF at 120 Hz, +25 °C				
Vdc	10 - 16	25 - 35	50 - 63	100
DF %	30	25	20	15

For values that are $>1000\text{ }\mu\text{F}$, the DF (%) increases 2% for every additional $1000\text{ }\mu\text{F}$

DC Leakage Test: $I \leq 0.03CV$ or 3 mA
 C = capacitance in μF
 V = rated voltage
 I = leakage current in μA

Frequency Ripple Multipliers:

Rated Vdc	Ripple Multipliers				
	60 Hz	120 Hz	1 kHz	10 kHz	100 kHz
10 to 35	0.90	1.00	1.05	1.10	1.10
50 to 100	0.90	1.00	1.15	1.20	1.20

Temperature Ripple Multipliers:

Temperature	Ripple Multiplier
+70 °C	1.20
+60 °C	1.30
+45 °C	1.55

Part Numbering System

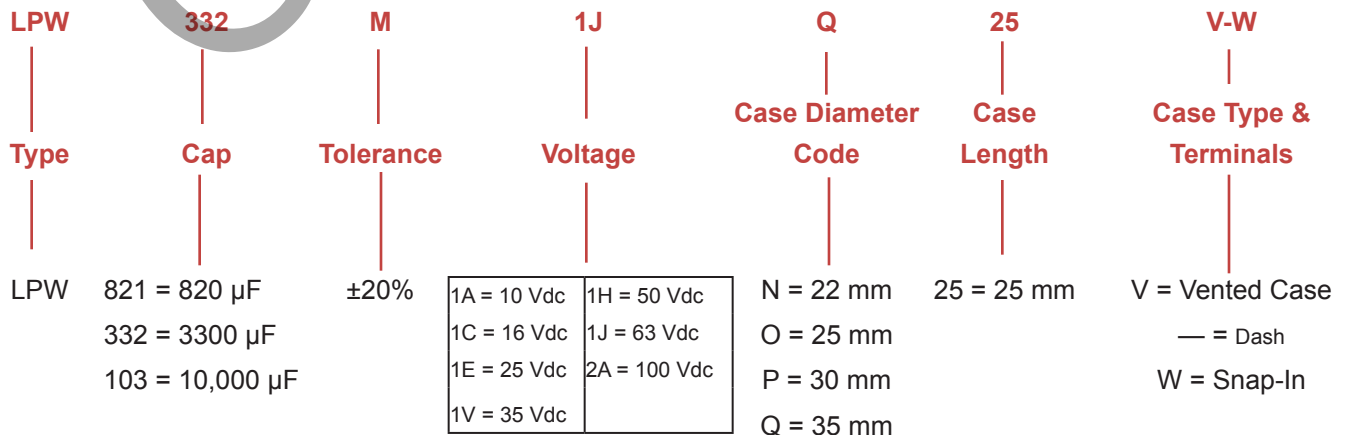

Type LPW 85 °C Snap-In Aluminum Electrolytic Capacitors

Outline Drawing

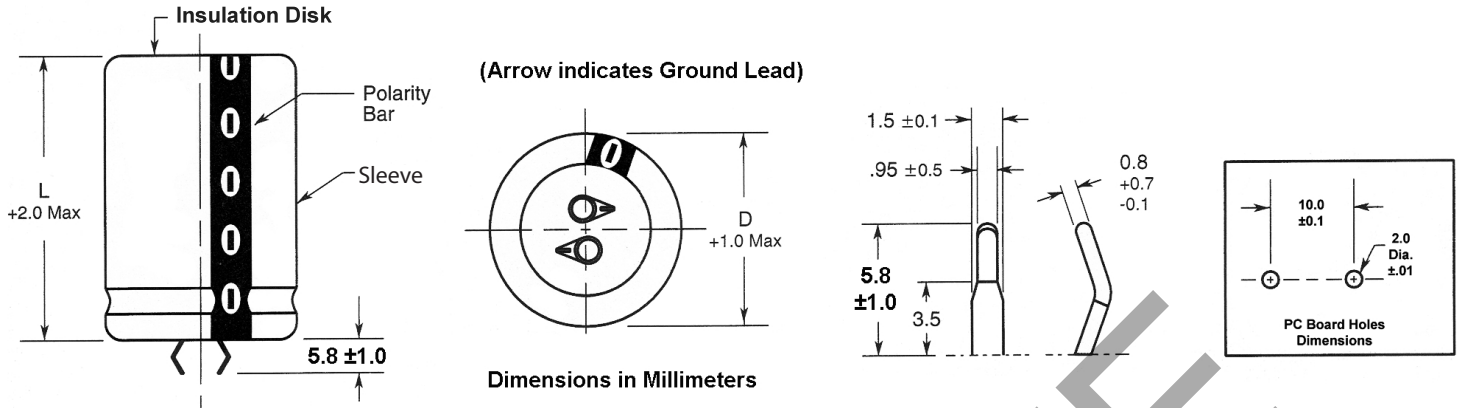

Ratings

Cap (µF)	Catalog Part Number	Max ESR @ 120 Hz +25 °C (Ω)	Max Ripple @ 120 Hz +85 °C (A)	Size (Inches)		Size (mm)	
				D	L	D	L
10 Vdc; 13 Vdc Surge							
8,200	LPW822M1AN25V-W	0.101	2.39	0.866	0.984	22	25
8,200	LPW822M1AO25V-W	0.101	2.46	0.984	0.984	25	25
10,000	LPW103M1AN30V-W	0.083	2.69	0.866	1.181	22	30
10,000	LPW103M1AO25V-W	0.083	2.57	0.984	0.984	25	25
12,000	LPW123M1AN30V-W	0.083	2.81	0.866	1.181	22	30
12,000	LPW123M1AP25V-W	0.083	2.84	1.181	0.984	30	25
15,000	LPW153M1AN35V-W	0.066	3.14	0.866	1.378	22	35
15,000	LPW153M1AP25V-W	0.066	2.97	1.181	0.984	30	25
22,000	LPW223M1AN45V-W	0.045	3.79	0.866	1.772	22	45
22,000	LPW223M1AP30V-W	0.045	3.45	1.181	1.181	30	30
16 Vdc; 20 Vdc Surge							
4,700	LPW472M1CN25V-W	0.141	1.81	0.866	0.984	22	25
4,700	LPW472M1CO25V-W	0.141	2.21	0.984	0.984	25	25
6,800	LPW682M1CN25V-W	0.122	2.40	0.866	0.984	22	25
6,800	LPW682M1CO25V-W	0.122	2.47	0.984	0.984	25	25
8,200	LPW822M1CN30V-W	0.101	2.70	0.866	1.181	22	30
8,200	LPW822M1CP25V-W	0.101	2.73	1.181	0.984	30	25
10,000	LPW103M1CN35V-W	0.083	3.00	0.866	1.378	22	35
10,000	LPW103M1CP25V-W	0.083	2.84	1.181	0.984	30	25
12,000	LPW123M1CN40V-W	0.069	3.30	0.866	1.575	22	40
12,000	LPW123M1CP30V-W	0.069	3.16	1.181	1.181	30	30
15,000	LPW153M1CN45V-W	0.055	3.62	0.866	1.772	22	45
15,000	LPW153M1CQ25V-W	0.055	3.55	1.378	0.984	35	25
22,000	LPW223M1CO45V-W	0.038	4.25	0.984	1.772	25	45
22,000	LPW223M1CQ30V-W	0.038	4.37	1.378	1.181	35	30
25 Vdc; 32 Vdc Surge							
3,300	LPW332M1EN25V-W	0.176	2.03	0.866	0.984	22	25
3,300	LPW332M1EO25V-W	0.176	2.09	0.984	0.984	25	25
4,700	LPW472M1EN30V-W	0.159	2.49	0.866	1.181	22	30
4,700	LPW472M1EO25V-W	0.159	2.31	0.984	0.984	25	25
6,800	LPW682M1EN35V-W	0.110	2.87	0.866	1.378	22	35

Cap (µF)	Catalog Part Number	Max ESR @ 120 Hz +25 °C (Ω)	Max Ripple @ 120 Hz +85 °C (A)	Size (Inches)		Size (mm)	
				D	L	D	L
25 Vdc; 32 Vdc Surge							
6,800	LPW682M1EP25V-W	0.110	2.72	1.181	0.984	30	25
8,200	LPW822M1EN40V-W	0.091	3.16	0.866	1.575	22	40
8,200	LPW822M1EP30V-W	0.091	3.03	1.181	1.181	30	30
10,000	LPW103M1EN45V-W	0.075	3.45	0.866	1.772	22	45
10,000	LPW103M1EP30V-W	0.075	3.14	1.181	1.181	30	30
12,000	LPW123M1EN50V-W	0.062	3.74	0.866	1.969	22	50
12,000	LPW123M1EQ30V-W	0.062	3.75	1.378	1.181	35	30
15,000	LPW153M1EO45V-W	0.050	3.78	0.984	1.772	25	45
15,000	LPW153M1EQ30V-W	0.050	3.89	1.378	1.181	35	30
22,000	LPW223M1EP50V-W	0.034	4.94	1.181	1.969	30	50
35 Vdc; 44 Vdc Surge							
3,300	LPW332M1VN25V-W	0.176	2.04	0.866	0.984	22	25
3,300	LPW332M1VO25V-W	0.176	2.10	0.984	0.984	25	25
4,700	LPW472M1VN30V-W	0.123	2.41	0.866	1.181	22	30
4,700	LPW472M1VP25V-W	0.123	2.44	1.181	0.984	30	25
6,800	LPW682M1VN40V-W	0.085	2.98	0.866	1.575	22	40
6,800	LPW682M1VP30V-W	0.085	2.86	1.181	1.181	30	30
8,200	LPW822M1VN45V-W	0.071	3.25	0.866	1.772	22	45
8,200	LPW822M1VQ30V-W	0.071	3.42	1.378	1.181	35	30
10,000	LPW103M1VO45V-W	0.058	3.41	0.984	1.772	25	45
10,000	LPW103M1VQ30V-W	0.058	3.51	1.378	1.181	35	30
12,000	LPW123M1VO50V-W	0.048	3.68	0.984	1.969	25	50
12,000	LPW123M1VQ35V-W	0.048	3.84	1.378	1.378	35	35
15,000	LPW153M1VP45V-W	0.039	4.08	1.181	1.772	30	45
50 Vdc; 63 Vdc Surge							
2,200	LPW222M1HN25V-W	0.226	1.92	0.866	0.984	22	25
2,200	LPW222M1HO25V-W	0.226	1.98	0.984	0.984	25	25
3,300	LPW332M1HN35V-W	0.151	2.51	0.866	1.378	22	35
3,300	LPW332M1HP25V-W	0.151	2.38	1.181	0.984	30	25
4,700	LPW472M1HN40V-W	0.106	2.89	0.866	1.575	22	40
4,700	LPW472M1HQ25V-W	0.106	2.99	1.378	0.984	35	25

Type LPW 85 °C Snap-In Aluminum Electrolytic Capacitors

Cap (μ F)	Catalog Part Number	Max ESR @ 120 Hz +25 °C (Ω)	Max Ripple @ 120 Hz +85 °C (A)	Size (Inches)		Size (mm)	
				D	L	D	L
				50 Vdc; 63 Vdc Surge			
6,800	LPW682M1HO45V-W	.073	3.37	0.984	1.772	25	45
6,800	LPW682M1HQ30V-W	0.073	3.46	1.378	1.181	35	30
8,200	LPW822M1HO50V-W	0.061	3.62	0.984	1.969	25	50
8,200	LPW822M1HQ35V-W	0.061	3.79	1.378	1.378	35	35
10,000	LPW103M1HP45V-W	0.050	3.72	1.181	1.772	30	45
63 Vdc; 79 Vdc Surge							
1,000	LPW102M1JN25V-W	0.414	1.42	0.866	0.984	22	25
1,000	LPW102M1JO25V-W	0.414	1.46	0.984	0.984	25	25
1,500	LPW152M1JN25V-W	0.276	1.74	0.866	0.984	22	25
1,500	LPW152M1JP25V-W	0.276	1.81	1.181	0.984	30	25
2,200	LPW222M1JN30V-W	0.226	2.08	0.866	1.181	22	30
2,200	LPW222M1JP25V-W	0.226	2.10	1.181	0.984	30	25
3,300	LPW332M1JN45V-W	0.151	2.81	0.866	1.772	22	45
3,300	LPW332M1JQ25V-W	0.151	2.76	1.378	0.984	35	25
4,700	LPW472M1JO45V-W	0.106	3.11	0.984	1.772	25	45
4,700	LPW472M1JQ30V-W	0.106	3.20	1.378	1.181	35	30
6,800	LPW682M1JP45V-W	0.073	3.54	1.181	1.772	30	45

Cap (μ F)	Catalog Part Number	Max ESR @ 120 Hz +25 °C (Ω)	Max Ripple @ 120 Hz +85 °C (A)	Size (Inches)		Size (mm)	
				D	L	D	L
				100 Vdc; 125 Vdc Surge			
820	LPW821M2AN30V-W	0.404	1.55	0.866	1.181	22	30
820	LPW821M2AO25V-W	0.404	1.54	0.984	0.984	25	25
1,000	LPW102M2AN30V-W	0.332	1.71	0.866	1.181	22	30
1,000	LPW102M2AP25V-W	0.332	2.20	1.181	0.984	30	25
1,500	LPW152M2AN40V-W	0.276	2.38	0.866	1.575	22	40
1,500	LPW152M2AQ30V-W	0.276	2.54	1.378	1.181	35	30
2,200	LPW222M2AO45V-W	0.188	2.77	0.984	1.772	25	45
2,200	LPW222M2AQ30V-W	0.188	3.07	1.378	1.181	35	30
3,300	LPW332M2AP45V-W	0.126	3.27	1.181	1.772	30	45

Notice and Disclaimer: All product drawings, descriptions, specifications, statements, information and data (collectively, the "Information") in this datasheet or other publication are subject to change. The customer is responsible for checking, confirming and verifying the extent to which the Information contained in this datasheet or other publication is applicable to an order at the time the order is placed. All Information given herein is believed to be accurate and reliable, but it is presented without any guarantee, warranty, representation or responsibility of any kind, expressed or implied. Statements of suitability for certain applications are based on the knowledge that the Cornell Dubilier company providing such statements ("Cornell Dubilier") has of operating conditions that such Cornell Dubilier company regards as typical for such applications, but are not intended to constitute any guarantee, warranty or representation regarding any such matter – and Cornell Dubilier specifically and expressly disclaims any guarantee, warranty or representation concerning the suitability for a specific customer application, use, storage, transportation, or operating environment. The Information is intended for use only by customers who have the requisite experience and capability to determine the correct products for their application. Any technical advice inferred from this Information or otherwise provided by Cornell Dubilier with reference to the use of any Cornell Dubilier products is given gratis (unless otherwise specified by Cornell Dubilier), and Cornell Dubilier assumes no obligation or liability for the advice given or results obtained. Although Cornell Dubilier strives to apply the most stringent quality and safety standards regarding the design and manufacturing of its products, in light of the current state of the art, isolated component failures may still occur. Accordingly, customer applications which require a high degree of reliability or safety should employ suitable designs or other safeguards (such as installation of protective circuitry or redundancies or other appropriate protective measures) in order to ensure that the failure of an electrical component does not result in a risk of personal injury or property damage. Although all product-related warnings, cautions and notes must be observed, the customer should not assume that all safety measures are indicated in such warnings, cautions and notes, or that other safety measures may not be required.