



Chipsmall Limited consists of a professional team with an average of over 10 year of expertise in the distribution of electronic components. Based in Hongkong, we have already established firm and mutual-benefit business relationships with customers from,Europe,America and south Asia,supplying obsolete and hard-to-find components to meet their specific needs.

With the principle of “Quality Parts,Customers Priority,Honest Operation,and Considerate Service”,our business mainly focus on the distribution of electronic components. Line cards we deal with include Microchip,ALPS,ROHM,Xilinx,Pulse,ON,Everlight and Freescale. Main products comprise IC,Modules,Potentiometer,IC Socket,Relay,Connector.Our parts cover such applications as commercial,industrial, and automotives areas.

We are looking forward to setting up business relationship with you and hope to provide you with the best service and solution. Let us make a better world for our industry!



Contact us

Tel: +86-755-8981 8866 Fax: +86-755-8427 6832

Email & Skype: info@chipsmall.com Web: www.chipsmall.com

Address: A1208, Overseas Decoration Building, #122 Zhenhua RD., Futian, Shenzhen, China



PRODUCT SPECIFICATIONS

SHARP

AVC Liquid Crystal Displays Group

LQ084S3DG01

TFT-LCD Module

Spec. Issue Date: April 11, 2006

No: LCY-03115D

PREPARED BY: <i>Kanayo Tazuta</i>	SHARP	SPEC No. LCY-03115D
APPROVED BY: <i>Nobuki Yabumichi</i>		FILE No.
	MOBILE LIQUID CRYSTAL DISPLAY GROUP	ISSUED: April. 11.2006
	SHARP CORPORATION	PAGE : 15 pages
	SPECIFICATION	APPLICABLE GROUP
		MOBILE LIQUID CRYSTAL DISPLAY GROUP

DEVICE SPECIFICATION FOR
TFT-LCD module
 MODEL No. LQ084S3DG01

CUSTOMER'S APPROVAL

DATE _____

BY _____

PRESENTED

H. Hamada

H. HAMADA
 Department General manager
 Engineering Department. 1
 Mobile LCD Design Center
 Mobile Liquid Crystal Display Group 1
 SHARP CORPORATION

RECORDS OF REVISION

MODEL No:LQ084S3DG01

SPEC No :LCY-03115

	NO.	PAGE	SUMMARY	NOTE				
2003.10.17		-	-	1st Issue				
2004.06.03	03115A	4	A clerical error "CNA,CNB" is corrected.	2nd Issue				
		6	"Lamp voltage" is added.					
		14	"Bezel Open Area" is added.					
2004.11.15	03115B	13	Lot No. Label : LQ084S3DG01 "A"	3rd Issue				
2005.04.06	03115C	2	Addition:"This module is adapted to RoHS compliance."	4th Issue				
		3,14	Change:Used connector DF19G-30P-1H→DF19G-30P-1H(56)					
		4	Addition:4-2【Note】"The input voltage...phase."					
		6	Addition:6-2【Note3】"The input voltage...of life."					
		11	Addition:【Note2】"The best viewing angle...reversed."					
		13	Change : 14 .Others LotNo.Label "A" → "R" (after "Model name")					
2006.04.11	03115D	4	Change : Tsg -25℃~70℃→30℃~80℃ Topp -10℃~+65℃→-30℃~80℃	5th Issue				
		7	Revise : Clock MAX 41MHz→42MHz					
		10	Change: Viewing angle range θ 21, θ 22, θ 12 TYP 65→80 Change:Contrast ratio 250→320 Change: Response time τ r 20→7, τ d 40→23					
		13	Change:No1 High temperature Ta=70℃→80℃ No2 Low temperature Ta=-25℃→-30℃ No4 High temperature Ta=65℃→80℃ No5 Low temperature Ta=-10℃→-30℃ No.6 Gravity 9.8→19.6m/s ² Addition: 14 . Others LotNo.Label Assembling in Hungary					
		<table border="1" style="margin: auto;"> <tr> <td style="padding: 5px;">LQ084S3DG01 I *****</td> </tr> </table>			LQ084S3DG01 I *****			
		LQ084S3DG01 I *****						
		<table style="margin: auto;"> <tr> <td style="border: none; padding: 0 10px;"> </td> <td style="border: none; padding: 0 10px;"> </td> </tr> <tr> <td style="border: none; text-align: center;">Model No.</td> <td style="border: none; text-align: center;">Serial No.</td> </tr> </table>					Model No.	Serial No.
		Model No.	Serial No.					
		14	Addition: •Assembling in Hungary •Barcord label(in Hungarian assembling) •label of origin country(in Hungarian assembling)					

NOTICE

This publication is the proprietary of SHARP and is copyrighted, with all rights reserved. Under the copyright laws, no part of this publication may be reproduced or transmitted in any form or by any means, electronic or mechanical for any purpose, in whole or in part, without the express written permission of SHARP. Express written permission is also required before any use of this publication may be made by a third party.

The application circuit examples in this publication are provided to explain the representative applications of SHARP's devices and are not intended to guarantee any circuit design or permit any industrial property right or other rights to be executed. SHARP takes no responsibility for any problems related to any industrial property right or a third party resulting from the use of SHARP's devices, except for those resulting directly from device manufacturing processes.

In the absence of confirmation by device specification sheets, SHARP takes no responsibility for any defects that occur in equipment using any of SHARP's devices, shown in catalogs, data books, etc. Contact SHARP in order to obtain the latest device specification sheets before using any SHARP's device.

SHARP reserves the right to make changes in the specifications, characteristics, data, materials, structures and other contents described herein at any time without notice in order to improve design or reliability. Contact SHARP in order to obtain the latest specification sheets before using any SHARP's device. Manufacturing locations are also subject to change without notice.

Observe the following points when using any device in this publication. SHARP takes no responsibility for damage caused by improper use of the devices.

The devices in this publication are designed for general electronic equipment use.

The appropriate design measures should be taken to ensure reliability and safety when SHARP's devices are used for equipment such as:

- Transportation control and safety equipment (i. e., aircraft, trains, automobiles, etc.)
- Traffic signals • Gas leakage sensor breakers • Alarm equipment • Various safety devices etc.

SHARP's devices shall not be used for equipment that requires extremely high level of reliability, such as:

- Military and space applications • Nuclear power control equipment
- Medical equipment for life support

Contact a SHARP representative, in advance, when intending to use SHARP's devices for any "specific" applications other than those recommended by SHARP.

Contact and consult with a SHARP representative if there are any questions about the contents of this publication.

1. Application

This specification applies to color TFT-LCD module, LQ084S3DG01.

2. Overview

- This module is a color active matrix LCD module incorporating amorphous silicon TFT (Thin Film Transistor).
- It is composed of a color TFT-LCD panel, driver ICs, control circuit and powersupply circuit and a backlight unit. Graphics and texts can be displayed on a $800 \times 3 \times 600$ dots panel with 262,144 colors by supplying 18 bit data signal (6bit/color), two timing signals, +3.3V DC supply voltage for TFT-LCD panel driving and supply voltage for backlight.
- The TFT-LCD panel used for this module is a low-reflection and higher-color-saturation type. Therefore, this module is also suitable for the multimedia use.
- Viewing angle is 6 o'clock direction.
- This module is the type of wide viewing angle and high brightness(350cd/m^2).
Backlight-driving DC/AC inverter is not built in this module.
- This module is adapted to RoHS compliance.

3. Mechanical Specifications

Parameter	Specifications	Unit
Display size (Diagonal)	21.3 (8.4" type)	cm
Active Display area	170.4(H) × 127.8(V)	mm
Pixel format	800(H) × 600(V)	pixel
	(1 pixel=R+G+B dots)	—
Pixel pitch	0.213(H) × 0.213(V)	mm
Pixel configuration	R,G,B vertical stripe	—
Display mode	Normally white	—
Dimension *1	199.5(W) × 149.5(H) × 11.6 (D)	mm
Mass	405 (MAX.)	g

*1. Protrusions not included. Refer to Fig.1 TFT-LCD Module Structure Diagram for details.

4. Input Terminals

4-1. TFT-LCD Panel driving section

CN1 Used connector:DF19G-30P-1H(56) (HROSE ELECTRIC CO.,LTD)

Table 4-1

Pin No.	Symbol	Function	Remarks
1	GND	—	—
2	Vcc	+3.3V power supply	—
3	Vcc	+3.3V power supply	—
4	GND	—	—
5	ENAB	DATA ENABLE signal(Horizontal-Vertical composite signal)	—
6	B5	BLUE data signal(MSB)	—
7	B4	BLUE data signal	—
8	B3	BLUE data signal	—
9	B2	BLUE data signal	—
10	B1	BLUE data signal	—
11	B0	BLUE data signal(LSB)	—
12	GND	—	—
13	G5	GREEN data signal(MSB)	—
14	G4	GREEN data signal	—
15	G3	GREEN data signal	—
16	G2	GREEN data signal	—
17	G1	GREEN data signal	—
18	G0	GREEN data signal(LSB)	—
19	GND	—	—
20	R5	RED data signal(MSB)	—
21	R4	RED data signal	—
22	R3	RED data signal	—
23	R2	RED data signal	—
24	R1	RED data signal	—
25	R0	RED data signal(LSB)	—
26	GND	—	—
27	NC	—	—
28	NC	—	—
29	CK	Clock signal for sampling each data signal	—
30	GND	—	—

4-2. Backlight fluorescent tube driving section

Used connector : BHR-04VS-1(JST)

Corresponding connector :SM04(4.0)B-BHS(JST)

Pin no.	Symbol	Function
1	V _{HIGH}	Power supply for lamp (High voltage terminal)
2	V _{HIGH}	Power supply for lamp (High voltage terminal)
3	NC	This is electrically opened.
4	V _{LOW}	Power supply for lamp (Low voltage terminal)

【Note】

The input voltage wave forms to terminal ① and terminal ② should be in a same phase.

It has the possibility to discharge abnormally between the terminals in case of input in a reversed phase.

5. Absolute Maximum Ratings

Parameter	Symbol	Condition	Ratings	Unit	Remark
Input voltage	V _I	T _a =25°C	-0.3 ~ V _{CC} +0.3	V	【Note1】
+3.3V supply voltage	V _{CC}	T _a =25°C	0 ~ +5.5	V	—
Storage temperature	T _{stg}	—	-30 ~ +80	°C	【Note2,3】
Operating temperature (Panel surface)	T _{opp}	—	-30 ~ +80	°C	【Note2,3,4,5】

【Note1】CK, R0~R5, G0~G5, B0~B5, ENAB

【Note2】No parameter is allowed to exceed the range.

【Note3】Humidity: 95%RH Max. at T_a ≤ 40°C.

Maximum wet-bulb temperature should be 39°C or less at T_a > 40°C. No condensation.

【Note4】The Panel surface, When backlight is on.(Reference)

【Note5】Only operation is guaranteed at operating temperature. Contrast, response time, and other display quality should be evaluated at +25°C.

6. Electrical characteristics

6-1. TFT-LCD Panel driving

Ta=25°C

Parameter	Symbol	Min	Typ	Max	Unit	Remarks	
+3.3V	Supply voltage	Vcc	+3.0	+3.3	+3.6	V	【Note1】
	Current dissipation	Icc	—	430	580	mA	【Note2】
Permissible input ripple voltage		VRF	—	—	100	mVp-p	Vcc=+3.3V
Input voltage (Low)		VIL	0	—	0.3Vcc	V	【Note3】
Input voltage (High)		VIH	0.7Vcc	—	Vcc	V	
Input current (low)		IOL1	—	—	1.0	μA	VI=0V 【Note4】
		IOL2	—	—	3.0	μA	VI=0V 【Note5】
Input current (High)		IOH1	—	—	1.0	μA	VI=Vcc 【Note6】
		IOH2	10	—	100	μA	VI=Vcc 【Note7】

【Note1】

Vcc-turn-on conditions

- $0 < t_1 \leq 15 \text{ ms}$
- $0 < t_2 \leq 80 \text{ ms}$
- $0 < t_3 \leq 1 \text{ s}$
- $t_4 > 1 \text{ s}$

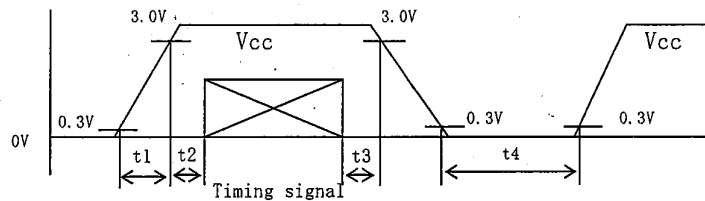

and data

Vcc-dip conditions

- 1) $2.7 \text{ V} \leq V_{cc} < 3.0 \text{ V}$
 $t_d \leq 10 \text{ ms}$
- 2) $V_{cc} < 2.7 \text{ V}$

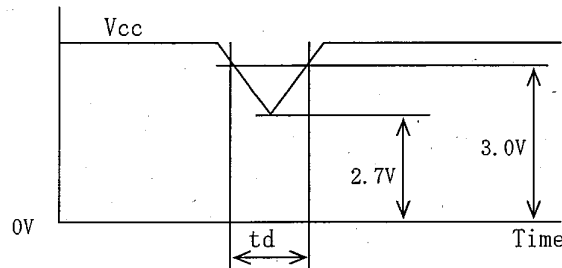

※Vcc-dip conditions should also follow the Vcc-turn-on conditions

【Note2】Vcc=+3.3V

Typical current situation : 16-gray-bar pattern. Timing : Typical signal

Maximum current situation : Vertical stripe pattern by GS0 and GS42 signal on every other lines.

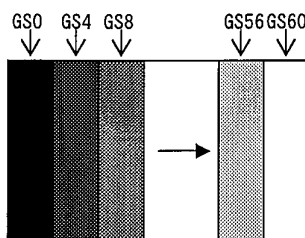

Typical current situation

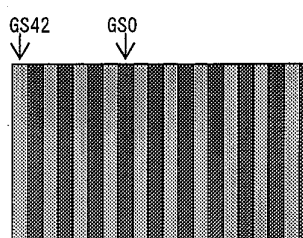

Maximum current situation

【Note3】CK,R0~R5, G0~G5,B0~B5,ENAB 【Note4】 CK,R0~R5,G0~G5,B0~B5

【Note5】 ENAB 【Note6】 CK,R0~R5,G0~G5,B0~B5 【Note7】 ENAB

6-2. Backlight Driving Section

The backlight system is an edge-lighting type with two CCFTs (Cold Cathode Fluorescent Tube).

The characteristics of single lamp are shown in the following table.

Ta=25°C

Parameter	Symbol	Min.	Typ.	Max.	Unit	Remarks
Lamp voltage	VL	340	380	420	Vrms	IL=6mArms
Lamp current	IL	3.0	6.0	6.5	mArms	【Note1】
Lamp power consumption	PL	—	2.3	—	W	【Note2】
Lamp frequency	FL	45	—	100	KHz	
Kick-off voltage	Vs	—	—	890	Vrms	Ta=25°C
		—	—	1,000		Ta=-10°C【Note3】
Lamp life time	LL	—	50,000	—	hour	【Note4】

【Note1】Lamp current is measured with current meter for high frequency as shown below.

【Note2】At the condition of $Y_L = 350 \text{ cd/m}^2$

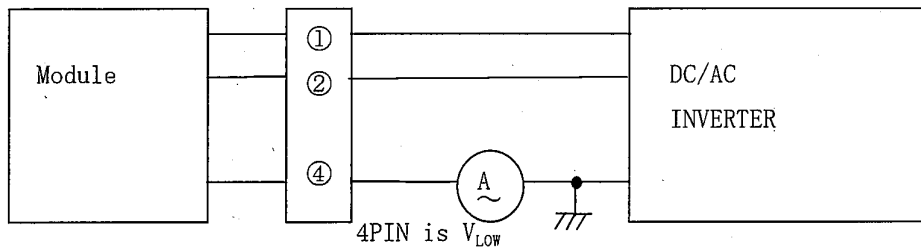

【Note3】The open output voltage of the inverter shall be maintained for more than 1sec; otherwise the lamp may not be turned on.

The input voltage wave forms to terminal ① and terminal ② should be in a same phase. It has the possibility to discharge abnormally between the terminals in case of input of a reversed phase.

For the sake of the safety, please so design the inveter as to prevent abnormal discharge when one of the two lamps is broken or reaches the end of life.

【Note4】 a)Lamp life time is defined as the time until it becomes the conditions either ① or ② by continuous lighting under the standard condition(Ta= 25°C, IL= 6m Arms*2).

① When a brightness of lamp surface became 50% of the initial value under the standard condition.

② When a kick-off voltage in Ta= -10°C exceeded maximum value 1,000 Vrms.

b) In case of operating under lower temp. environment, the lamp exhaustion is accelerated and the brightness becomes lower.

(Continuous operating for around 1 month under lower temp. condition may reduce the brightness to half of the original brightness.)

In case of such usage under lower temp. environment, periodical lampexchange is recommended.

【Note】The performance of the backlight, for example life time or brightness, is much influenced by the characteristics of the DC-AC inverter for the lamp. When you design or order the inverter, please make sure that an inadequate lighting caused by the mismatch of the backlight and the inverter (miss-lighting, flicker, etc.) never occur. When you confirm it, the module should be operated in the same condition as it is installed in your instrument.

7. Timing Characteristics of Input Signals

Timing diagrams of input signal are shown in Fig.2.

7-1. Timing Characteristics

Parameter		Symbol	Min.	Typ.	Max.	Unit
Clock	Frequency	1/Tc	—	40	42	MHz
	Period	Tc	23.8	25	—	ns
	High time	Tch	9	—	—	ns
	Low time	Tcl	9	—	—	ns
	Duty	Tch:Tcl	40:60	50:50	60:40	—
Data	Setup time	Tds	7	—	—	ns
	Hold time	Tdh	7	—	—	ns
ENAB	Setup time	Tes	7			ns
	One line scanning time	TH	944*Tc	1056*Tc	1064*Tc	—
			26.3	26.4	—	μs
	Horizontal Pulse width	THp	2	800	TH-10	clock
	Frame period	TV	604*TH	628*TH	677*TH	—
—			16.58	17.85	ms	
Horizontal display period		THd	800	800	800	clock
Vertical display period		THc	600	600	600	Line

Note) In case of lower frame frequency, the deterioration of display quality, flicker etc., may be occurred.

7-2. Input Data Signals and Display Position on the screen

Display position of input data

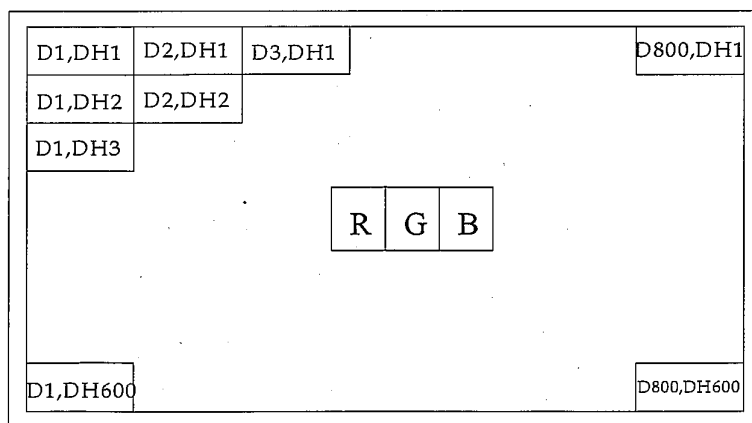

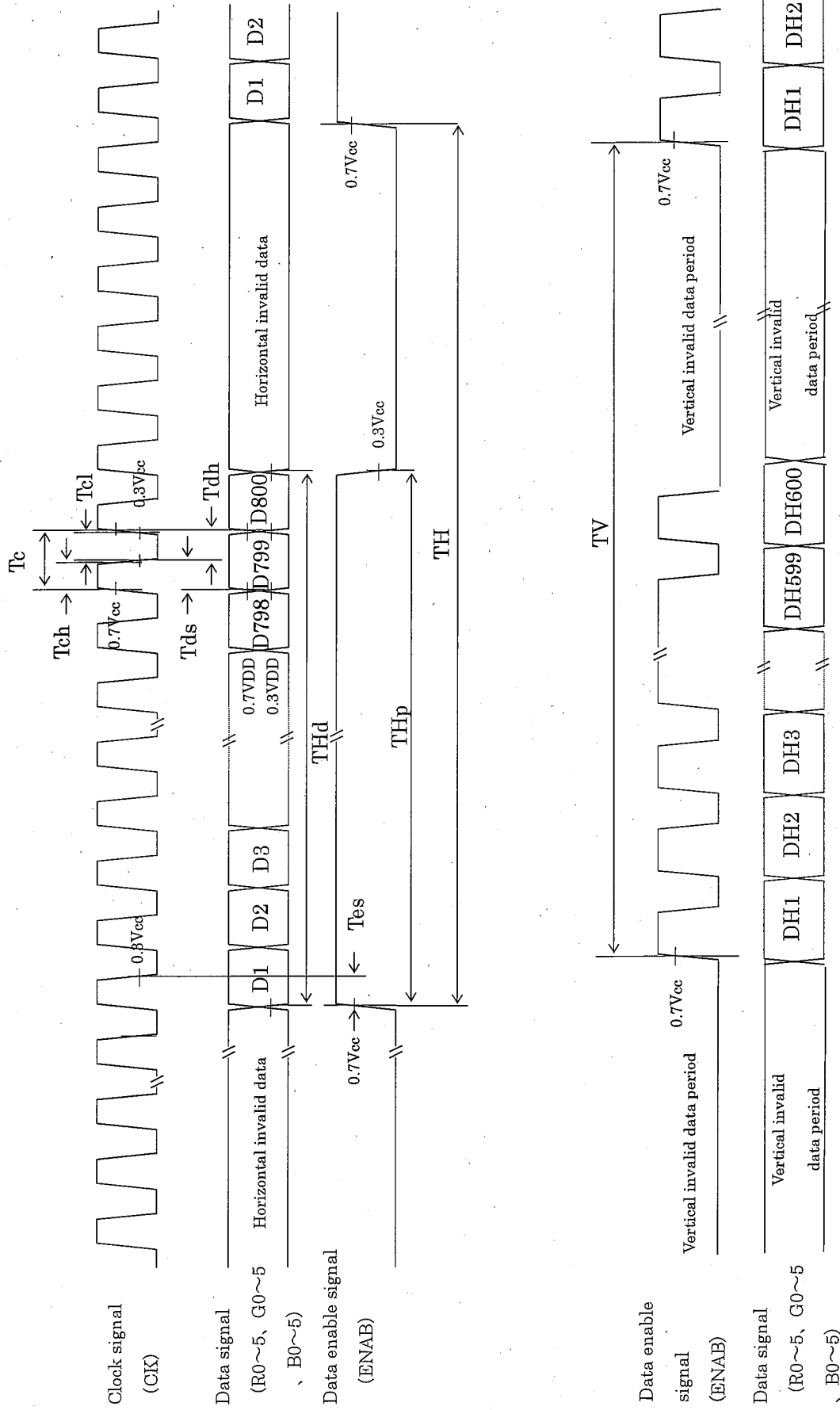

fig1. Input signal timing

8. Input Signals, primary Display Colors and Gray Scale of Each Color

	Colors & Gray scale	Data signal																		
		Gray Scale	R0	R1	R2	R3	R4	R5	G0	G1	G2	G3	G4	G5	B0	B1	B2	B3	B4	B5
Basic Color	Black	—	0	0	0	0	0	0	0	0	0	0	0	0	0	0	0	0	0	0
	Blue	—	0	0	0	0	0	0	0	0	0	0	0	0	1	1	1	1	1	1
	Green	—	0	0	0	0	0	0	1	1	1	1	1	1	0	0	0	0	0	0
	Cyan	—	0	0	0	0	0	0	1	1	1	1	1	1	1	1	1	1	1	1
	Red	—	1	1	1	1	1	1	0	0	0	0	0	0	0	0	0	0	0	0
	Magenta	—	1	1	1	1	1	1	0	0	0	0	0	0	1	1	1	1	1	1
	Yellow	—	1	1	1	1	1	1	1	1	1	1	1	1	0	0	0	0	0	0
	White	—	1	1	1	1	1	1	1	1	1	1	1	1	1	1	1	1	1	1
Gray Scale of Red	Black	GS0	0	0	0	0	0	0	0	0	0	0	0	0	0	0	0	0	0	0
	↑ Darker	GS1	1	0	0	0	0	0	0	0	0	0	0	0	0	0	0	0	0	0
		GS2	0	1	0	0	0	0	0	0	0	0	0	0	0	0	0	0	0	0
	↑ ↓	↓				↓					↓					↓				
		↓				↓					↓					↓				
	Brighter ↓	GS61	1	0	1	1	1	1	0	0	0	0	0	0	0	0	0	0	0	0
		GS62	0	1	1	1	1	1	0	0	0	0	0	0	0	0	0	0	0	0
	Red	GS63	1	1	1	1	1	1	0	0	0	0	0	0	0	0	0	0	0	0
Gray Scale of Green	Black	GS0	0	0	0	0	0	0	0	0	0	0	0	0	0	0	0	0	0	0
	↑ Darker	GS1	0	0	0	0	0	0	1	0	0	0	0	0	0	0	0	0	0	0
		GS2	0	0	0	0	0	0	0	1	0	0	0	0	0	0	0	0	0	0
	↑ ↓	↓				↓					↓					↓				
		↓				↓					↓					↓				
	Brighter ↓	GS61	0	0	0	0	0	0	1	0	1	1	1	1	0	0	0	0	0	0
		GS62	0	0	0	0	0	0	0	1	1	1	1	1	0	0	0	0	0	0
	Green	GS63	0	0	0	0	0	0	1	1	1	1	1	1	0	0	0	0	0	0
Gray Scale of Blue	Black	GS0	0	0	0	0	0	0	0	0	0	0	0	0	0	0	0	0	0	0
	↑ Darker	GS1	0	0	0	0	0	0	0	0	0	0	0	0	1	0	0	0	0	0
		GS2	0	0	0	0	0	0	0	0	0	0	0	0	0	1	0	0	0	0
	↑ ↓	↓				↓					↓					↓				
		↓				↓					↓					↓				
	Brighter ↓	GS61	0	0	0	0	0	0	0	0	0	0	0	0	1	0	1	1	1	1
		GS62	0	0	0	0	0	0	0	0	0	0	0	0	0	1	1	1	1	1
	Blue	GS63	0	0	0	0	0	0	0	0	0	0	0	0	1	1	1	1	1	1

0 :Low level voltage, 1 : High level voltage

Each primary color can be displayed in 64 gray scales from 6 bit data signals. According to the combination of total 18 bit data signals, the 262,144-color display can be achieved on the screen.

9. Optical Specification

Ta=25°C, Vcc=+3.3V

Parameter	Symbol	Condition	Min.	Typ.	Max.	Unit	Remark	
Viewing angle range	Horizontal	$\theta 21$	(CR \geq 5)	60	80	—	Deg.	【Note1,4】
		$\theta 22$		60	80	—	Deg.	
	Vertical	$\theta 11$		40	45	—	Deg.	
		$\theta 12$		60	80	—	Deg.	
Contrast ratio	CR	$\theta = 0^\circ$	60	—	—	—	【Note2,4】	
		Best viewing angle	—	320	—	—		
Response time	Rise	τr	$\theta = 0^\circ$	—	7	—	ms	【Note3,4】
	Decay	τd		—	23	—	ms	
Chromaticity of white	X	—	—	0.263	0.313	0.363	—	【Note4,5】
	Y			0.279	0.329	0.379	—	
Luminance	YL	—	—	260	350	—	cd/m ²	—
Direction of panel viewing angle	—	—	—	6		—	o'clock	【Note6】

※ Measured 30 minutes after turning on.

(typical condition:IL=6mAms)

The optical specification must be measured in a dark room or equivalent state with the method shown in Fig.3 below.

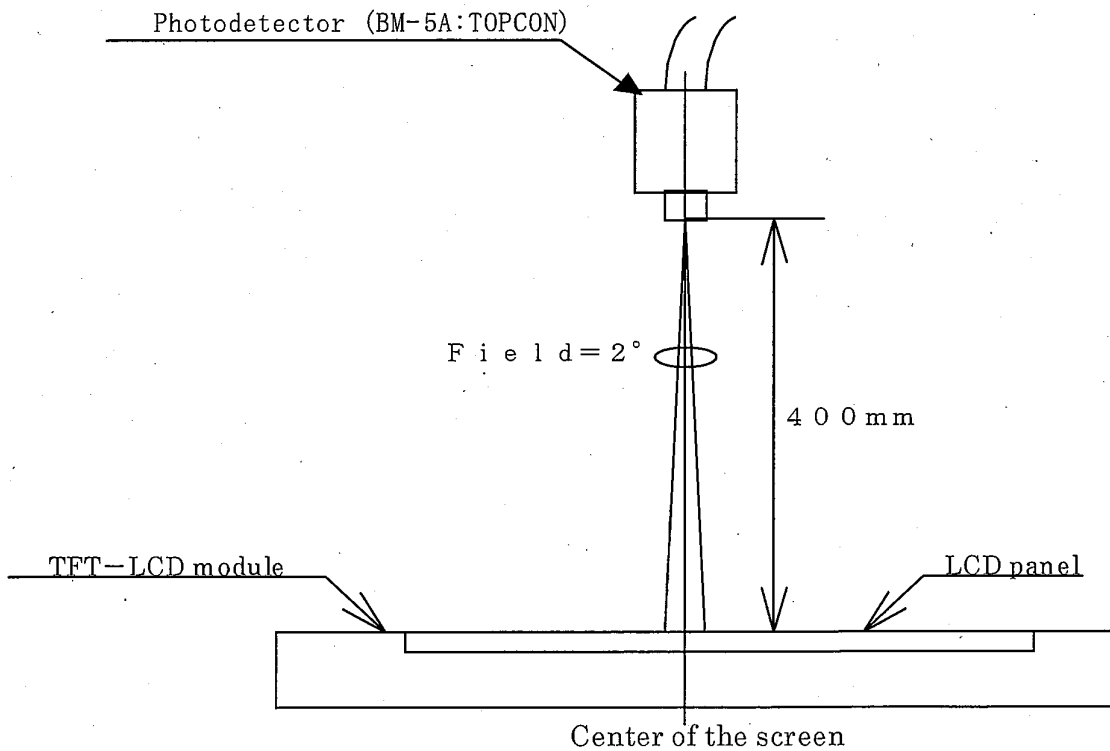
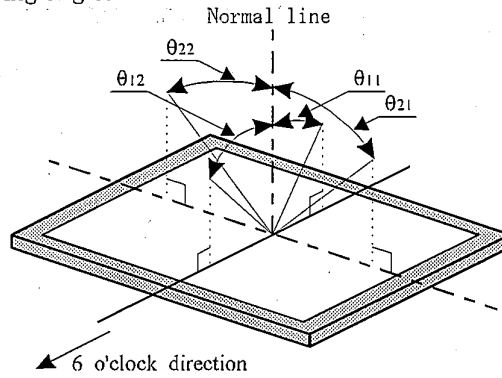

Fig.3 Optical characteristics measurement method

【Note1】Definitions of viewing angle:



【Note2】Definition of contrast ratio:

The contrast ratio is defined as the following.

$$\text{Contrast Ratio (CR)} = \frac{\text{Luminance (brightness) with all pixels white}}{\text{Luminance (brightness) with all pixels black}}$$

The best viewing angle of this module is slightly leaned to 6 o'clock from normal line. In the field where θ_{12} exceeds this angle, gray-scale is reversed partially. The gray-scale in the field of 12 o'clock direction is brighter than that of 6 o'clock direction and isn't reversed.

【Note3】Definition of response time:

The response time is defined as the following figure and shall be measured by switching the input signal for "black" and "white".

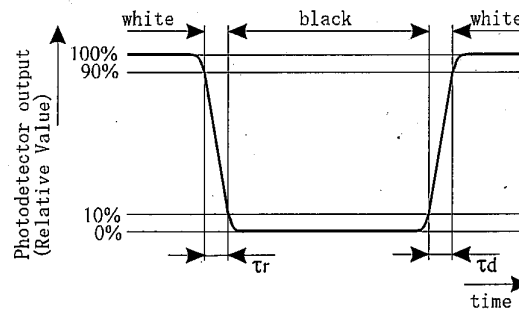

【Note4】This shall be measured at center of the screen.

【Note5】Backlight :ON , TFT-LCD :Power and Signal OFF(Normally White state)

【Note6】In the direction of 6 o'clock, Gray scale reverse occurs.

10. Display Quality

The criteria for the display quality of the color LCD module depends on Incoming Inspection Standard.

11. Handling Precautions

- a) Be sure to turn off the power and signals for module before plugging/unplugging cable to/from the connector.
- b) Be sure to design the cabinet so that the module can be installed without any extra stress such as warp or twist.
- c) Since the front polarizer is easily damaged, pay attention to avoid rubbing with something hard or sharp.
- d) Wipe off water drop immediately. Long contact with water may cause discoloration or spots.
- e) When the panel surface is soiled, wipe it with absorbent cotton or other soft cloth.
- f) Since the panel is made of glass and refined wires and components, it may break, crack or internal wire breaking if dropped or bumped on hard surface. Handle with care.
- g) Since CMOS LSI is used in this module, pay attention to static electricity and ground the human body when handling to prevent failure.
- h) Observe all other precautionary requirements in handling electronic components.
- i) This module has its circuitry PWBs on the rear side and should be carefully handled in order not to be stressed.
- j) The polarizer surface on the panel is treated with Anti-Glare for low reflection. In case of attaching protective board over the LCD. Be careful about the optical interference fringe etc. which degrades display quality.
- k) Connect GND to 4 place of mounting holes to stabilize against EMI and external noise.
- l) There are high voltage portions on the backlight and very dangerous. Careless touch may lead to electrical shock. When you exchange lamps or service, please turn off the power .
- m) Be sure not to apply tensile stress to the lamp lead cable.

12. Packing Form

- a) Piling number of cartons: MAX. 6
- b) Package quantity in one carton: 10 pcs
- c) Carton size : 408(W)×203(D)×244(H)mm
- d) Total mass of 1 carton filled with full modules: 6 kg

13. Reliability Test Items

No.	Test item	Conditions
1	High temperature storage test	Ta= 80°C 240h
2	Low temperature storage test	Ta=-30°C 240h
3	High temperature & high humidity operation test	Ta= 40°C ; 95%RH 240h (No condensation)
4	High temperature operation test	Ta= 80°C(Panel surface) 240h
5	Low temperature operation test	Ta=-30°C 240h
6	Vibration test (non- operating)	Frequency : 10~57Hz/Vibration width (one side):0.075mm : 58~500Hz/Gravity:19.6m/s ² Sweep time : 11 minutes Test period : 3 hours (1 hour for each direction of X, Y, Z)
7	Shock test (non- operating)	Max. acceleration : 490m/s ² Pulse width : 11ms, half sine wave Direction : ±X, ±Y, ±Z once for each direction.

【Result Evaluation Criteria】

Under the display quality test conditions with normal operation state, these shall be no change which may affect practical display function.

14. Others

1) Lot No. Label:

Assembling in Japan

LQ084S3DG01 R *****

Model No.

Serial No.

Assembling in Hungary

LQ084S3DG01 I *****

Model No.

Serial No.

- 2) Adjusting volume have been set optimally before shipment, so do not change any adjusted value. If adjusted value is changed, the specification may not be satisfied.
- 3) Disassembling the module can cause permanent damage and should be strictly avoided.
- 4) Please be careful since image retention may occur when a fixed pattern is displayed for a long time.
- 5) If any problem occurs in relation to the description of this specification , it shall be resolved through discussion with spirit of cooperation.
- 6) Do not use LCD module in the atmosphere of corrosive gases, such as sulfide gas or chlorine gases. Polarizer may be deteriorated or cause chemical reaction that can lead to short circuits at the terminal points. Do not use the material, which compounds contain sulfide or chlorine compounds in the vicinity of LCD module. At high temperature, these compounds may produce corrosive gases.
- 7) Do not expose the module to direct sunlight or intensive ultraviolet rays for many hours; liquid crystal is deteriorated by ultraviolet rays.

SHARP

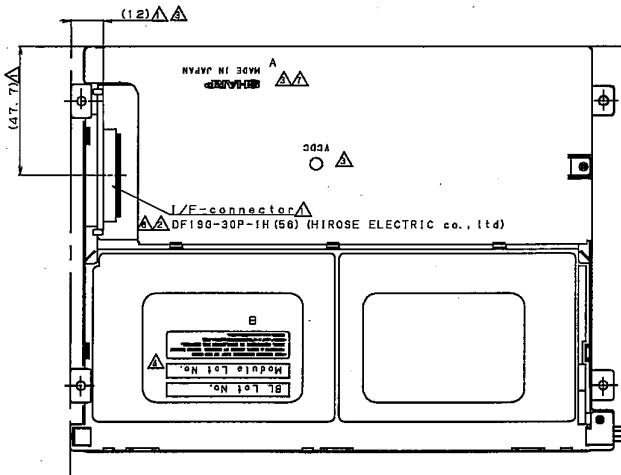
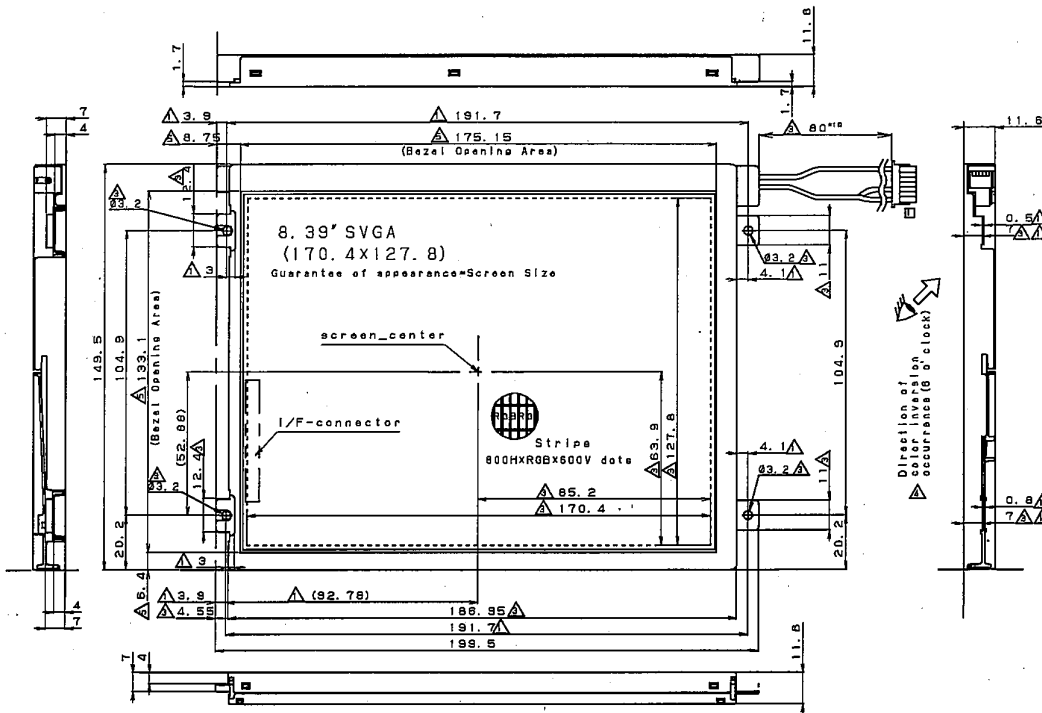

(Country of origin display)	
Assembling in Japan	Assembling in Hungary
MADE IN JAPAN (detail A)	(detail A)
(detail B)	(detail B)

BHR-04VS-1:J.S.T Mfg co., Ltd

General tolerance is ±0.5.
Take care in set design to hide the scratches and bubbles appeared on the polarizer or other frame area which is located outside of active area.

unit:mm	Please do not copy this material and do not disclose this to third party.	△06.03.30	ADD BARCODE LABEL	ITOH
		△05.12.14	ADD COUNTRY OF ORIGIN	ITOU
DATE	2003.01.14	△05.04.05	CHANGE I/F CONNECTOR MODEL No.	ITOH
MODEL	LQ0834S3DG0	△04.06.03	ADD Bezel opening area dimensions.	KATO
DRAWING NO	CM-030091	△03.11.05	ADD Module Lot No. Labels and Direction of color inversion occurrence	KATO
		△03.08.25	ADD BL wire length and Module fix position height (Right side). ADD hole for VR adjustment and standpad end dimensions.	KATO
SCALE	free	△03.07.30	ADD BL and I/F CONNECTOR MODEL No.	KATO
size	A2	△03.03.17	CHANGE BL WIRE POSITION/CHANGE HOLE POSITION FOR FIX THE MODULE	KATO
		No.	DATE	REVISION
ENGINEERING DEPARTMENT I MOBILE LCD DESIGN CENTER MOBILE LIQUID CRYSTAL DISPLAY GROUP SHARP CORP.				

OUTLINE DIMENSIONS

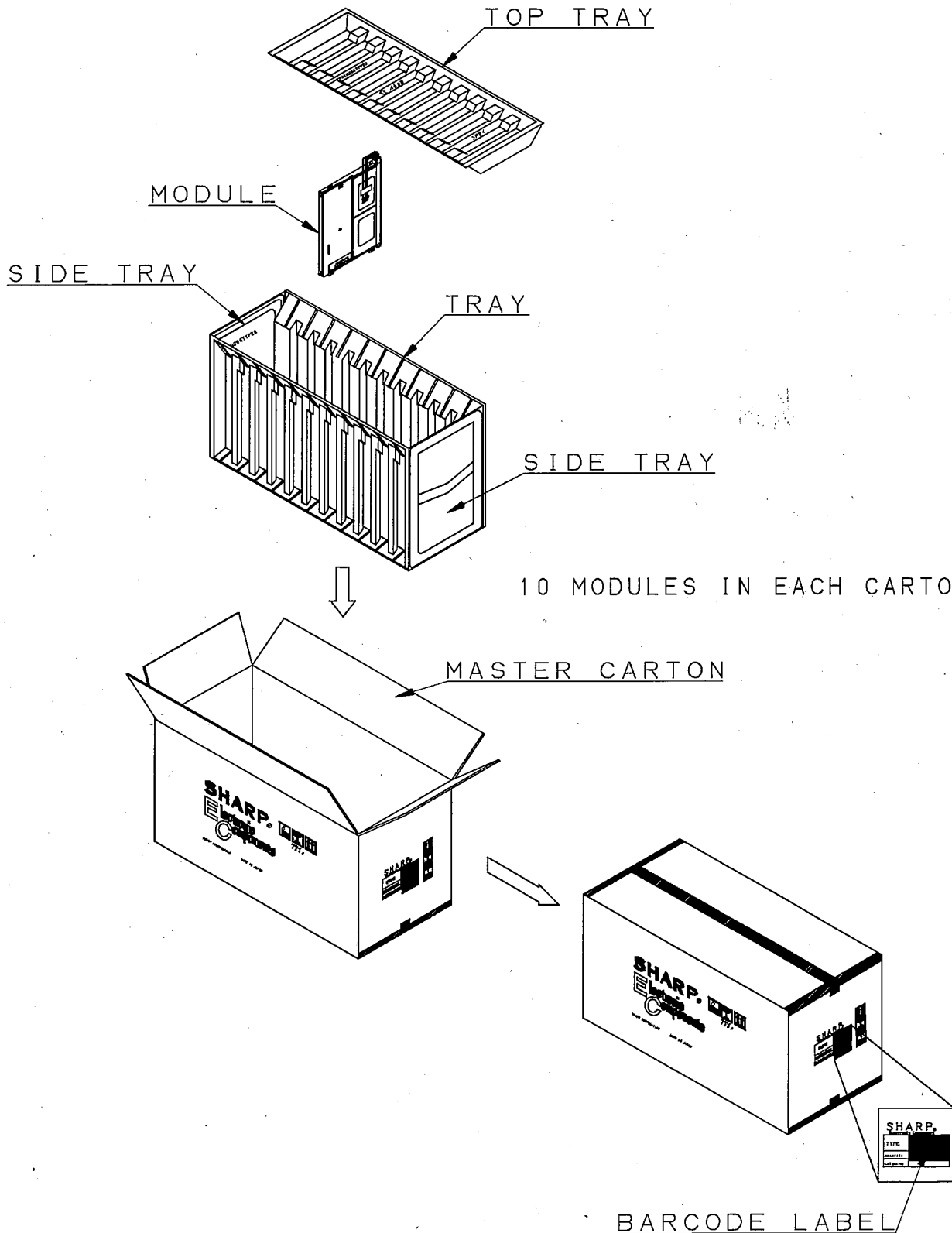

PACKING FORM

NOTICE

This publication is the proprietary of SHARP and is copyrighted, with all rights reserved. Under the copyright laws, no part of this publication may be reproduced or transmitted in any form or by any means, electronic or mechanical for any purpose, in whole or in part, without the express written permission of SHARP. Express written permission is also required before any use of this publication may be made by a third party.

The application circuit examples in this publication are provided to explain the representative applications of SHARP's devices and are not intended to guarantee any circuit design or permit any industrial property right or other rights to be executed. SHARP takes no responsibility for any problems related to any industrial property right or a third party resulting from the use of SHARP's devices, except for those resulting directly from device manufacturing processes.

In the absence of confirmation by device specification sheets, SHARP takes no responsibility for any defects that occur in equipment using any of SHARP's devices, shown in catalogs, data books, etc. Contact SHARP in order to obtain the latest device specification sheets before using any SHARP's device.

SHARP reserves the right to make changes in the specifications, characteristics, data, materials, structures and other contents described herein at any time without notice in order to improve design or reliability. Contact SHARP in order to obtain the latest specification sheets before using any SHARP's device. Manufacturing locations are also subject to change without notice.

Observe the following points when using any device in this publication. SHARP takes no responsibility for damage caused by improper use *of the devices*.

The appropriate design measures should be taken to ensure reliability and safety when SHARP's devices are used for equipment such as:

- Transportation control and safety equipment (i.e., aircraft, trains, automobiles, etc.)
- Traffic signals
- Alarm equipment
- Gas leakage sensor breakers
- Various safety devices etc.

SHARP's devices shall not be used for equipment that requires extremely high level of reliability, such as:

- Military and space applications
- Medical equipment for life support
- Nuclear power control equipment

Contact a SHARP representative, in advance, when intending to use SHARP's devices for any "specific" applications other than those recommended by SHARP.

Contact and consult with a SHARP representative if there are any questions about the contents of this publication.

SPECIFICATIONS ARE SUBJECT TO CHANGE WITHOUT NOTICE.

Suggested applications (if any) are for standard use; See Important Restrictions for limitations on special applications. See Limited Warranty for SHARP's product warranty. The Limited Warranty is in lieu, and exclusive of, all other warranties, express or implied. ALL EXPRESS AND IMPLIED WARRANTIES, INCLUDING THE WARRANTIES OF MERCHANTABILITY, FITNESS FOR USE AND FITNESS FOR A PARTICULAR PURPOSE, ARE SPECIFICALLY EXCLUDED. In no event will SHARP be liable, or in any way responsible, for any incidental or consequential economic or property damage.

SHARP®

NORTH AMERICA

SHARP Microelectronics of the Americas
5700 NW Pacific Rim Blvd.
Camas, WA 98607, U.S.A.
Phone: (1) 360-834-2500
Fax: (1) 360-834-8903
Fast Info: (1) 800-833-9437
www.sharpsma.com

EUROPE

SHARP Microelectronics Europe
Division of Sharp Electronics (Europe) GmbH
Sonninstrasse 3
20097 Hamburg, Germany
Phone: (49) 40-2376-2286
Fax: (49) 40-2376-2232
www.sharpsme.com

JAPAN

SHARP Corporation
Electronic Components & Devices
22-22 Nagaike-cho, Abeno-Ku
Osaka 545-8522, Japan
Phone: (81) 6-6621-1221
Fax: (81) 6117-725300/6117-725301
www.sharp-world.com

TAIWAN

SHARP Electronic Components
(Taiwan) Corporation
8F-A, No. 16, Sec. 4, Nanking E. Rd.
Taipei, Taiwan, Republic of China
Phone: (886) 2-2577-7341
Fax: (886) 2-2577-7326/2-2577-7328

SINGAPORE

SHARP Electronics (Singapore) PTE., Ltd.
438A, Alexandra Road, #05-01/02
Alexandra Technopark,
Singapore 119967
Phone: (65) 271-3566
Fax: (65) 271-3855

KOREA

SHARP Electronic Components
(Korea) Corporation
RM 501 Geosung B/D, 541
Dohwa-dong, Mapo-ku
Seoul 121-701, Korea
Phone: (82) 2-711-5813 ~ 8
Fax: (82) 2-711-5819

CHINA

SHARP Microelectronics of China
(Shanghai) Co., Ltd.
28 Xin Jin Qiao Road King Tower 16F
Pudong Shanghai, 201206 P.R. China
Phone: (86) 21-5854-7710/21-5834-6056
Fax: (86) 21-5854-4340/21-5834-6057

Head Office:

No. 360, Bashen Road,
Xin Development Bldg. 22
Waigaoqiao Free Trade Zone Shanghai
200131 P.R. China
Email: smc@china.global.sharp.co.jp

HONG KONG

SHARP-ROXY (Hong Kong) Ltd.
3rd Business Division,
17/F, Admiralty Centre, Tower 1
18 Harcourt Road, Hong Kong
Phone: (852) 28229311
Fax: (852) 28660779
www.sharp.com.hk

Shenzhen Representative Office:

Room 13B1, Tower C,
Electronics Science & Technology Building
Shen Nan Zhong Road
Shenzhen, P.R. China
Phone: (86) 755-3273731
Fax: (86) 755-3273735