



Chipsmall Limited consists of a professional team with an average of over 10 year of expertise in the distribution of electronic components. Based in Hongkong, we have already established firm and mutual-benefit business relationships with customers from,Europe,America and south Asia,supplying obsolete and hard-to-find components to meet their specific needs.

With the principle of "Quality Parts,Customers Priority,Honest Operation,and Considerate Service",our business mainly focus on the distribution of electronic components. Line cards we deal with include Microchip,ALPS,ROHM,Xilinx,Pulse,ON,Everlight and Freescale. Main products comprise IC,Modules,Potentiometer,IC Socket,Relay,Connector.Our parts cover such applications as commercial,industrial, and automotives areas.

We are looking forward to setting up business relationship with you and hope to provide you with the best service and solution. Let us make a better world for our industry!



## Contact us

Tel: +86-755-8981 8866 Fax: +86-755-8427 6832

Email & Skype: info@chipsmall.com Web: www.chipsmall.com

Address: A1208, Overseas Decoration Building, #122 Zhenhua RD., Futian, Shenzhen, China



PREPARED BY :      DATE	<h1>SHARP</h1> <p>MOBILE LIQUID CRYSTAL DISPLAY GROUP SHARP CORPORATION</p> <h2>SPECIFICATION</h2>	SPEC No. LD-22303A
APPROVED BY :      DATE		FILE No.
		ISSUE : March. 5. 2010
		PAGE : 14 pages
		APPLICABLE GROUP MOBILE LIQUID CRYSTAL DISPLAY GROUP

DEVICE SPECIFICATION FOR  
**TFT-LCD Module**  
 MODEL No.  
**LQ085Y3DW01**

**These parts have corresponded with the RoHS directive.**

CUSTOMER'S APPROVAL

DATE \_\_\_\_\_

BY \_\_\_\_\_

PRESENTED BY J. Kawanishi

J. Kawanishi  
 General manager  
 ENGINEERING DEPARTMENT I  
 MOBILE LIQUID CRYSTAL DISPLAY DIVISION II  
 MOBILE LIQUID CRYSTAL DISPLAY GROUP  
 SHARP CORPORATION



**NOTICE**

This publication is the proprietary of SHARP and is copyrighted, with all rights reserved. Under the copyright laws, no part of this publication may be reproduced or transmitted in any form or by any means, electronic or mechanical for any purpose, in whole or in part, without the express written permission of SHARP. Express written permission is also required before any use of this publication may be made by a third party.

The application circuit examples in this publication are provided to explain the representative applications of SHARP's devices and are not intended to guarantee any circuit design or permit any industrial property right or other rights to be executed. SHARP takes no responsibility for any problems related to any industrial property right or a third party resulting from the use of SHARP's devices, except for those resulting directly from device manufacturing processes.

SHARP reserves the right to make changes in the specifications, characteristics, data, materials, structures and other contents described herein at any time without notice in order to improve design or reliability. Contact SHARP in order to obtain the latest specification sheets before using any SHARP's device. Manufacturing locations are also subject to change without notice.

Observe the following points when using any device in this publication. SHARP takes no responsibility for damage caused by improper use of the devices.

The devices in this publication are designed for general electronic equipment use.

- The appropriate design measures should be taken to ensure reliability and safety when SHARP's devices are used for equipment such as:
  - Transportation control and safety equipment(i.e.,aircraft, trains, automobiles, etc.)
  - Traffic signals • Gas leakage sensor breakers • Alarm equipment • Various safety devices etc.

SHARP's devices shall not be used for equipment that requires extremely high level of reliability, such as:

- Military and space applications
- Nuclear power control equipment
- Medical equipment for life support

Contact a SHARP representative, in advance, when intending to use SHARP's devices for any "specific" applications other than those recommended by SHARP.

Contact and consult with a SHARP representative if there are any questions about the contents of this publication.

## Applicable TFT-LCD module

This specification applies to the color TFT-LCD module, LQ085Y3DW01

### Overview

This module is a color active matrix transmissive LCD module incorporating amorphous silicon TFT (Thin Film Transistor).

It is composed of a color TFT-LCD panel, driver ICs, control circuits and power supply circuitry and a backlight unit. Graphics and texts can be displayed on a 800 x 480 x RGB dots panel with 16,777,216 colors by feeding 24 bit data signal (8bit/each of R,G,B), 3 timing signals, +3.3V DC power supply for TFT-LCD and AC power supply for backlight.

Fine images with stripe aligned 384,000 pixels on 8.5 inch diagonal screen.

Color display capability of 16,777,216 colors with 24 bit data signal (8 bits for each RGB).

- It is a wide viewing-angle-module for ASV technology
- High contrast, thanks to active matrix drive system.
- AG (Anti Glare) polarizing filter.
- Light and slim compact module achieved by (COG assemble technology. )
- These LCD modules have corresponded with the RoHS directive.

## 3 Mechanical Specifications

Items	Specifications	Unit
Display size (Diagonal)	21.6 (8.5")	cm
Active display area	184.8 (H) x 110.88 (V)	mm
Pixel format	800(H) x 480(V) x RGB	dot
	(1 pixel=R+G+B dots)	-
Pixel pitch	0.231[H] x 0.231[V]	mm
Pixel configuration	R,G,B horizontal stripe	-
LCD mode	ASV	-
Dimension*	210.0(W) x 134.0(H) x 7.0(D)	mm
Mass	210 (Typ )	g

\*. Protrusion such as backlight cable and I/F Connector are not included.

Fig.1 shows dimensions of the module.

## 4 Input Signal Assignment

### 4.1 TFT-LCD Panel driving section

CN1 FH12-50S-0.5SH(55) (HIROSE) \ Terminal :Au plating 【Note 4-1】

端子	記号	機能	極性
1	( Test 1 )	Test pin (Please be sure to open)	
2	G N D	Ground	
3	C K	Clock signal for sampling each data signal	
4	G N D	Ground	
5	( Test 2 )	Test pin (Please be sure to open)	
6	( Test 3 )	Test pin (Please be sure to open)	
7	R 0	RED Data signal ( L S B )	
8	R 1	RED Data signal	
9	R 2	RED Data signal	
1 0	R 3	RED Data signal	
1 1	G N D	Ground	
1 2	R 4	RED Data signal	
1 3	R 5	RED Data signal	
1 4	R 6	RED Data signal	
1 5	R 7	RED Data signal ( M S B )	
1 6	G N D	Ground	
1 7	G 0	GREEN Data signal ( L S B )	
1 8	G 1	GREEN Data signal	
1 9	G 2	GREEN Data signal	
2 0	G 3	GREEN Data signal	
2 1	G N D	Ground	
2 2	G 4	GREEN Data signal	
2 3	G 5	GREEN Data signal	
2 4	G 6	GREEN Data signal	
2 5	G 7	GREEN Data signal ( M S B )	
2 6	G N D	Ground	
2 7	B 0	Blue Data signal ( L S B )	
2 8	B 1	Blue Data signal	
2 9	B 2	Blue Data signal	
3 0	B 3	Blue Data signal	
3 1	G N D	Ground	
3 2	B 4	Blue Data signal	
3 3	B 5	Blue Data signal	
3 4	B 6	Blue Data signal	
3 5	B 7	Blue Data signal ( M S B )	
3 6	G N D	Ground	
3 7	G N D	Ground	
3 8	( Test 4 )	Test pin (Please be sure to open)	
3 9	( Test 5 )	Test pin (Please be sure to open)	
4 0	G N D	Ground	
4 1	Hsync	Horizontal synchronous signal	Low active
4 2	G N D	Ground	
4 3	Vsync	Vertical synchronous signal	Low active
4 4	( Test 6 )	Test pin (Please be sure to open)	
4 5	( E N A B )	Invalid in LCD.	
4 6	( Test 7 )	Test pin (Please be sure to open)	
4 7	V C C	+3.3V power supply	
4 8	V C C	+3.3V power supply	
4 9	V C C	+3.3V power supply	
5 0	V C C	+3.3V power supply	

【Note 4-1】 Refer to the one that the size of FFC/FPC was recommended it of input connector.  
The terminal of FFC/FPC of input connector recommend gold or gold plating specification.  
Because point of contact with its is gold plating specification.

## 4.2 Backlight section

### LED-FPC terminal arrangement

Pin No.	Symbol	Function
1	+ C H 4	Power Supply for LED (CH4 High voltage side)
2	+ C H 3	Power Supply for LED (CH3 High voltage side)
3	+ C H 2	Power Supply for LED (CH2 High voltage side)
4	+ C H 1	Power Supply for LED (CH1 High voltage side)
5	- C H 1	Power Supply for LED (CH1 Low voltage side)
6	- C H 2	Power Supply for LED (CH2 Low voltage side)
7	- C H 3	Power Supply for LED (CH3 Low voltage side)
8	- C H 4	Power Supply for LED (CH4 Low voltage side)

Fig.1 shows dimensions of the FPC.

## 5 Absolute Maximum Ratings

Parameter	Symbol	Condition	Ratings	Unit	Remark
Input voltage	$V_I$	$T_a=25^{\circ}\text{C}$	-0.3 ~ +3.6	V	【Note 5-1】
Supply voltage	$V_{cc}$	$T_a=25^{\circ}\text{C}$	0 ~ +4.0	V	-
Storage temperature	$T_{stg}$	-	-10 ~ +60	$^{\circ}\text{C}$	【Note 5-2】
Operating temperature (Panel surface)	$T_{opp}$	-	0 ~ +50	$^{\circ}\text{C}$	

【Note 5-1】 CK, R0 ~ R7, G0 ~ G7, B0 ~ B7, Hsync, Vsync

【Note 5-2】 Humidity: 95%RH Max. at  $T_a \leq 40^{\circ}\text{C}$ .

Maximum wet-bulb temperature at  $39^{\circ}\text{C}$  or less at  $T_a > 40^{\circ}\text{C}$ .

No condensation.

It may stop acting normally, when it operates it for a long time with having condensed.

## 6 Electrical characteristics

### 6.1 TFT-LCD Panel driving section

$T_a=25^{\circ}\text{C}$

Parameter	Symbol	Min.	Typ.	Max.	Unit	Remarks
Supply voltage	$V_{cc}$	+3.0	+3.3	+3.6	V	[Note6-1]
Current dissipation	$I_{cc}$	-	160	350	mA	$V_{cc}=3.3\text{V}$ [Note6-2]
Input voltage ("Low" state)	$V_{IL}$	0	-	$0.3 \times V_{cc}$	V	[Note6-3]
Input voltage ("High" state)	$V_{IH}$	$0.7 \times V_{cc}$	-	$V_{cc}$	V	
Input leakage current(low)	$I_{OL1}$	-1	-	1	$\mu\text{A}$	$V_{cc}=0\text{V}$ [Note6-3]
Input leakage current(High)	$I_{OH1}$	-1	-	1	$\mu\text{A}$	$V_{cc}=3.3\text{V}$ [Note6-3]

[Note6-1]  $V_{cc}$  turn-on/off conditions  
 $1.0\text{s} < t_0$

[Note6-2] Current dissipation : When  
Black pattern is displayed.

[Note6-3] CK, R0~R7, G0~G7, B0~B7,  
Hsync, Vsync

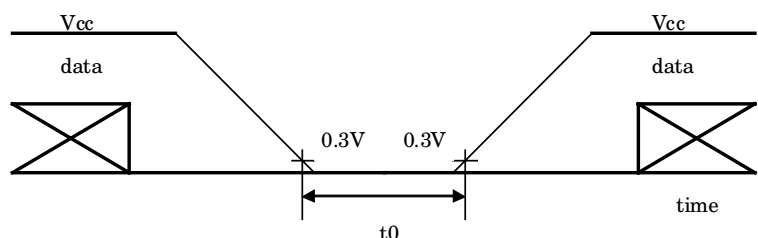

## 6.2 Vcc turn-on/off conditions

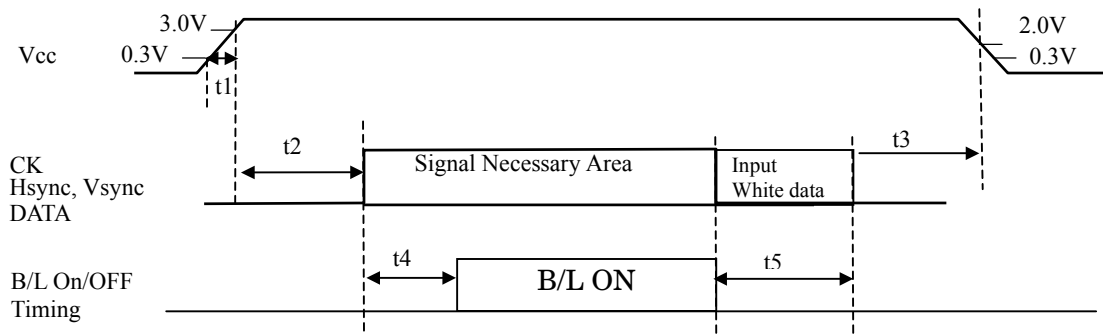

- ⊙ Every Signal is CMOS Input, Hi-Z is prohibited when VCC is on level.
- ⊙ Input CK, Hsync, Vsync, and DATA after it becomes regular amplitude and a frequency.

It is recommended to consider some timing difference between CMOS input and Backlight input as shown above.

If the Backlight lights on before LCD starting, or if the Backlight is kept on after LCD stopping, the screen may look white for a moment or abnormal image may be displayed. This is caused by variation in output signal from timing generator at CMOS input on or off. It does not cause the damage to the LCD module.

	Min.	Typ.	Max.	Unit
t1	0	-	10	ms
t2	0	-	20	ms
t3	-10	-	0.001	ms
t4	4	-	-	flame
t5	3	-	-	flame

## 6.3 Backlight driving Section

The backlight system is an edge-lighting type with white-LED.

The characteristics of LED are shown in the following table.

(It is usually required to measure under the following condition.

condition:  $I_L=20\text{mA}$  / Constant current drive,  $T_a=25^\circ\text{C}\pm 2^\circ\text{C}$ )

Parameter	Symbol	Min.	Typ.	Max.	Unit	Remark
LED voltage	$V_L$	-	28.8	31.5	V	Value for one channel
LED current range	$I_L$	-	20	21	mA	Value for one channel
Number of circuit channel		-	4	-		[Note6-4]
LED power consumption	$W_L$	-	-	2.65	W	[Note6-5]
Life time ( LCD module )	$L_L$	-	10000	-	Hour	[Note6-6]

[Note6-4] The LED backlight is composed of 4 channels which 9 LED is connected in series.

[Note6-5] Calculated value for reference ( $I_L \times V_L \times 4\text{channel}$ )

[Note6-6] ①Lighting condition:

- The state of the LCD module installation: Landscape position and standing position
- Atmosphere temperature:  $25^\circ\text{C}$
- Lighting current: 20mA (Constant current drive / Continuous turning on)

②Definition of Life time:

Brightness becomes 50% of the original value .(under condition ①)

[Note6-7]In the method of the parallel connection of the input of each channel and the drive, an excessive current flows to the channel side where the voltage is low, and, as a result, there is a possibility of causing the LED longevity decrease. It is preferable to do the fixed current drive only for each channel to each channel.



## 7 Timing Characteristics of Input Signals

Timing diagrams of input signal are shown in Fig.2.

### 7.1 Timing Characteristics

Parameter		Symbol	Min.	Typ.	Max.	Unit	Note
Clock	Frequency	1/Tc	31.95	33.26	34.6	MHz	
	“High” time	Tch	12	-	-	ns	
	“Low” time	Tcl	12	-	-	ns	
Data	Setup time	Tds	8	-	-	ns	
	Hold time	Tdh	8	-	-	ns	
Hsync	Period	TH	31.45	31.75	32.05	μs	
			1024	1056	1088	clock	
	Pulse width	THp	5	128	186	clock	
	Back porch + THp	THb		216(fixed)	-	line	
	Setup time	THs	8	-	Tc-8	ns	
Vsync	Period	TV	520	525	530	line	60Hz
	Pulse width	TVp	2	-	TV-515	line	
	Back porch	TVb		35(fixed)	-	line	
	Setup time	TVs	8	-	Tc-8	ns	
Phase difference between Hsync and Vsync		TVh	0	-	50	clock	
Horizontal display period		THd	-	800	-	clock	
Vertical display period		TVd	-	480	-	line	

Note) In case of lower frequency, the deterioration of display quality, flicker etc., may occur.

### 7.2 Display position in vertical direction.

↑ UP

Display position of input data (H,V)

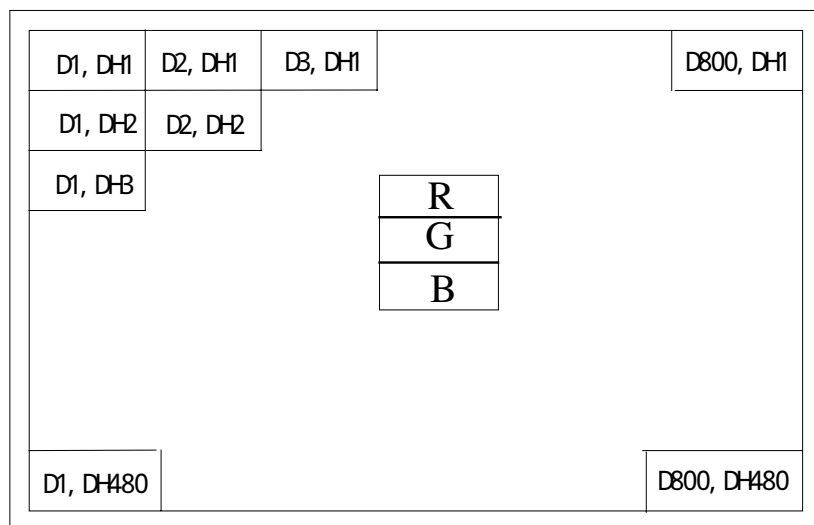

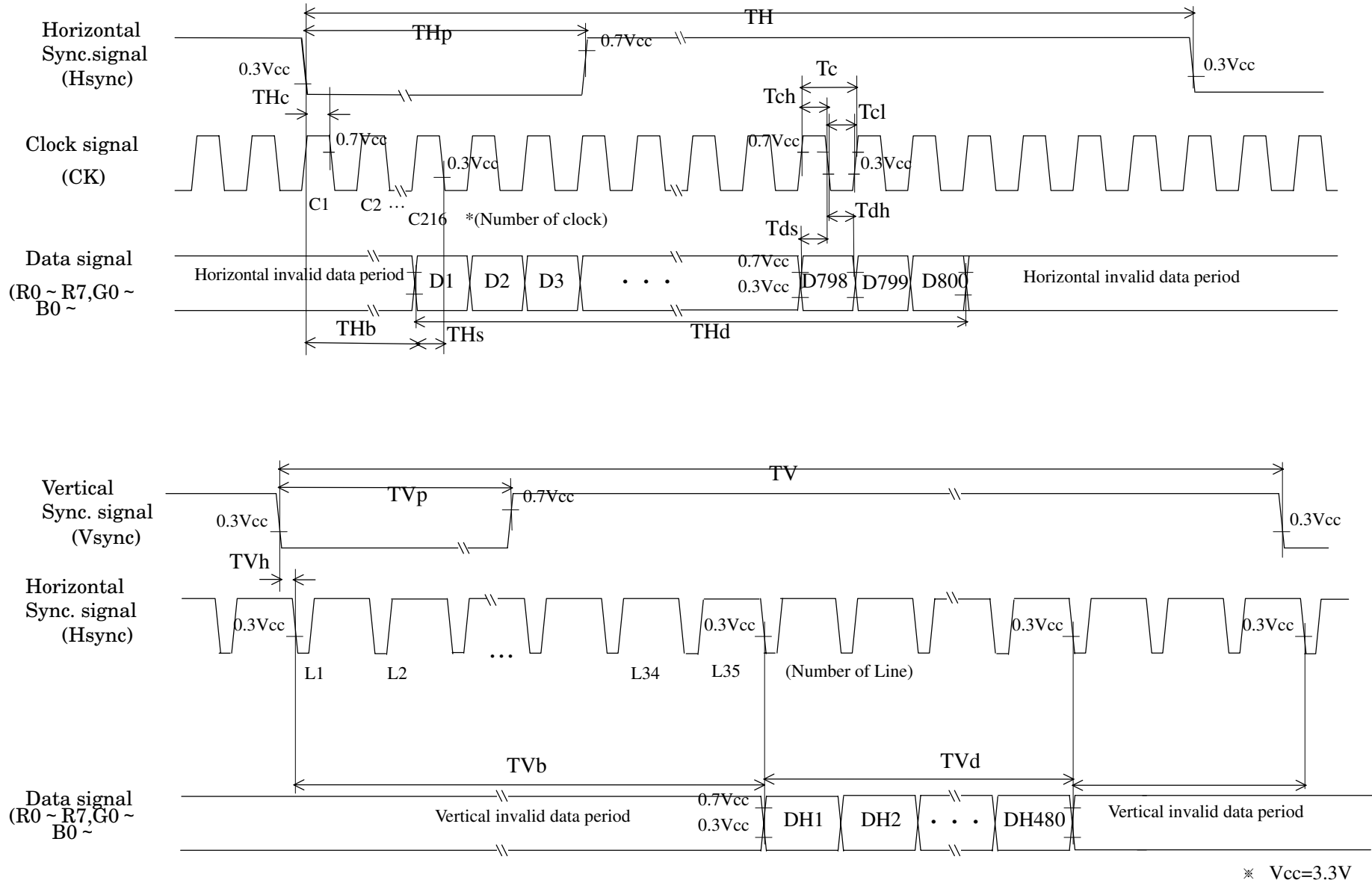

Fig.2 Input signal waveform

8 Input Signals, Basic Display Colors and Gray Scale of Each Color

	Colors & Gray scale	Data signal																								
		Gray Scale	R0	R1	R2	R3	R4	R5	R6	R7	G0	G1	G2	G3	G4	G5	G6	G7	B0	B1	B2	B3	B4	B5	B6	B7
Basic Color	Black	-	0	0	0	0	0	0	0	0	0	0	0	0	0	0	0	0	0	0	0	0	0	0	0	0
	Blue	-	0	0	0	0	0	0	0	0	0	0	0	0	0	0	0	0	1	1	1	1	1	1	1	1
	Green	-	0	0	0	0	0	0	0	0	1	1	1	1	1	1	1	1	0	0	0	0	0	0	0	0
	Cyan	-	0	0	0	0	0	0	0	0	1	1	1	1	1	1	1	1	1	1	1	1	1	1	1	1
	Red	-	1	1	1	1	1	1	1	1	0	0	0	0	0	0	0	0	0	0	0	0	0	0	0	0
	Magenta	-	1	1	1	1	1	1	1	1	0	0	0	0	0	0	0	0	1	1	1	1	1	1	1	1
	Yellow	-	1	1	1	1	1	1	1	1	1	1	1	1	1	1	1	1	0	0	0	0	0	0	0	0
	White	-	1	1	1	1	1	1	1	1	1	1	1	1	1	1	1	1	1	1	1	1	1	1	1	1
Gray Scale of Red	Black	GS0	0	0	0	0	0	0	0	0	0	0	0	0	0	0	0	0	0	0	0	0	0	0	0	0
	↑	GS1	1	0	0	0	0	0	0	0	0	0	0	0	0	0	0	0	0	0	0	0	0	0	0	0
	Darker	GS2	0	1	0	0	0	0	0	0	0	0	0	0	0	0	0	0	0	0	0	0	0	0	0	0
	↑	↓					↓							↓								↓				
	↓	↓					↓							↓								↓				
	Brighter	GS253	1	0	1	1	1	1	1	1	0	0	0	0	0	0	0	0	0	0	0	0	0	0	0	0
	↓	GS254	0	1	1	1	1	1	1	1	0	0	0	0	0	0	0	0	0	0	0	0	0	0	0	0
	Red	GS255	1	1	1	1	1	1	1	1	0	0	0	0	0	0	0	0	0	0	0	0	0	0	0	0
Gray Scale of Green	Black	GS0	0	0	0	0	0	0	0	0	0	0	0	0	0	0	0	0	0	0	0	0	0	0	0	0
	↑	GS1	0	0	0	0	0	0	0	0	1	0	0	0	0	0	0	0	0	0	0	0	0	0	0	0
	Darker	GS2	0	0	0	0	0	0	0	0	0	1	0	0	0	0	0	0	0	0	0	0	0	0	0	0
	↑	↓					↓							↓								↓				
	↓	↓					↓							↓								↓				
	Brighter	GS253	0	0	0	0	0	0	0	0	1	0	1	1	1	1	1	1	0	0	0	0	0	0	0	0
	↓	GS254	0	0	0	0	0	0	0	0	0	1	1	1	1	1	1	1	0	0	0	0	0	0	0	0
	Green	GS255	0	0	0	0	0	0	0	0	1	1	1	1	1	1	1	1	0	0	0	0	0	0	0	0
Gray Scale of Blue	Black	GS0	0	0	0	0	0	0	0	0	0	0	0	0	0	0	0	0	0	0	0	0	0	0	0	0
	↑	GS1	0	0	0	0	0	0	0	0	0	0	0	0	0	0	0	0	1	0	0	0	0	0	0	0
	Darker	GS2	0	0	0	0	0	0	0	0	0	0	0	0	0	0	0	0	0	1	0	0	0	0	0	0
	↑	↓					↓							↓								↓				
	↓	↓					↓							↓								↓				
	Brighter	GS253	0	0	0	0	0	0	0	0	0	0	0	0	0	0	0	0	1	0	1	1	1	1	1	1
	↓	GS254	0	0	0	0	0	0	0	0	0	0	0	0	0	0	0	0	0	1	1	1	1	1	1	1
	Blue	GS255	0	0	0	0	0	0	0	0	0	0	0	0	0	0	0	0	1	1	1	1	1	1	1	1

0 : Low level voltage, 1 : High level voltage.

Each basic color can be displayed in 256 gray scales from 8 bit data signals. According to the combination of total 24 bit data signals, the 16-million-color display can be achieved on the screen.

## 9 Optical Specification

Ta=25°C, Vcc=3.3V

Parameter		Symbol	Condition	Min.	Typ.	Max.	Unit	Remark
Viewing angle Range	Horizontal	θ21,θ22	CR≥10	78	88	-	° (Deg.)	[Note9-1,9-4]
	Vertical	θ11, θ12		78	88	-	° (Deg.)	
Contrast ratio		CR max	Best viewing angle	700	1000	-	-	[Note9-2,9-4]
Response time	Rise	Tr+Td	θ = 0°	-	35	40	ms	[Note9-3,9-4]
Chromaticity of white		x	θ = 0°	0.26	0.31	0.36	-	[Note9-4]
		y		0.28	0.33	0.38	-	
Luminance of white		L	θ = 0°	280	350	-	cd/m <sup>2</sup>	IL=20mAms [Note9-4]

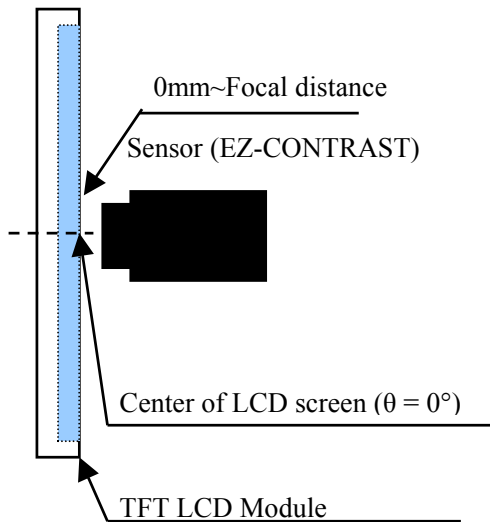

Fig.9-1 Measuring setup for Viewing angle and Contrast ratio

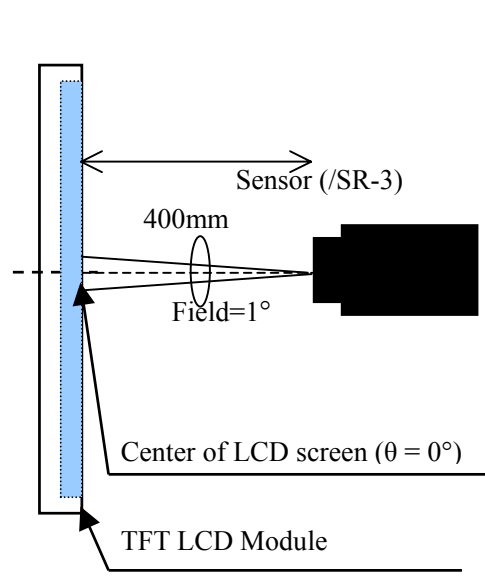
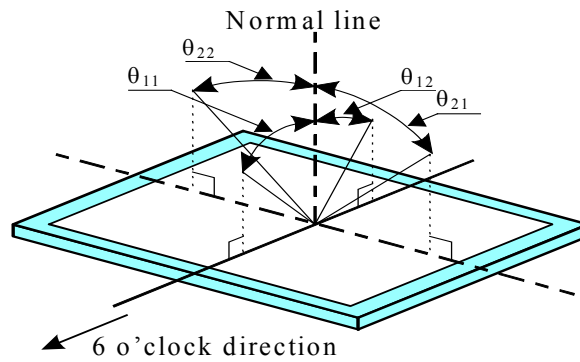

Fig.9-2 Measuring setup for Luminance, Chromaticity and Response time

[Note9-1] Definitions of viewing angle range:



[Note9-2] Definition of contrast ratio:

The contrast ratio is defined as the following.

$$\text{Contrast Ratio (CR)} = \frac{\text{Central luminance (brightness) with all pixels white}}{\text{Central luminance (brightness) with all pixels black}}$$

[Note9-3] Definition of response time:

The response time is defined as the following figure and shall be measured by switching the input signal between "black" and "white" alternatively.

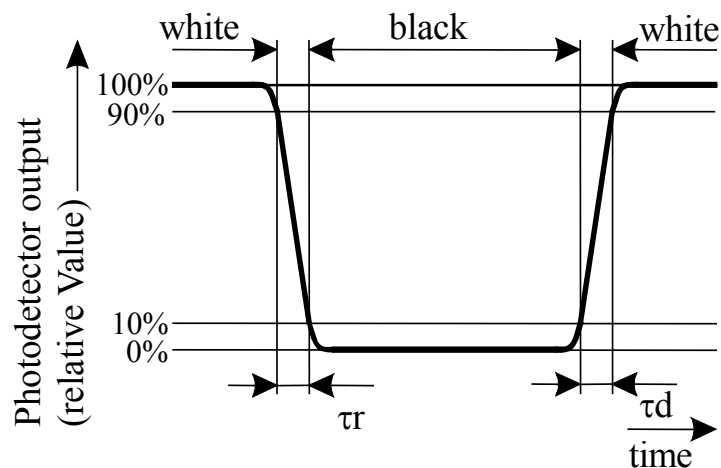

[Note9-4] This parameter should be measured at the center of the screen and 30 minutes after turn-on.

## 10 Display Qualities

Please refer to the Outgoing Inspection Standard.

## 11 Handling Instruction

- a) Be sure to turn off the power supply when inserting or disconnecting the cable.
- b) Be sure to design the cabinet so that the module can be installed without any extra stress such as warp or twist.
- c) Since the front polarizer is easily damaged, pay attention not to scratch it.  
Blow away dust on the polarizer with antistatic N<sub>2</sub> blow. It is undesirable to wipe off because a polarizer is sensitive.  
It is recommended to peel off softly using the adhesive tape when soil or finger oil is stuck to the polarizer.  
When unavoidable, wipe off carefully with a cloth for wiping lenses.
- d) Wipe off water drop immediately. Long contact with water may cause discoloration or spots.
- e) When the panel surface is soiled, wipe it with absorbent cotton or other soft cloth.
- f) Since the panel is made of glass, it may break or crack if dropped or bumped on hard surface. Handle with care.
- g) Since CMOS LSI is used in this module, take care of static electricity and injure the human earth when handling.  
Observe all other precautionary requirements in handling components.
- h) Since there is a circuit board in the module back, stress is not added at the time of a design assembly.  
Please make it like. If stress is added, there is a possibility that circuit parts may be damaged.
- i) Protection film is attached to the module surface to prevent it from being scratched .  
Peel the film off slowly , just before the use, with strict attention to electrostatic charges.  
Blow off 'dust' on the polarizer by using an ionized nitrogen.
- j) The polarizer surface on the panel is treated with Anti-Glare for low reflection. In case of attaching protective board over the LCD, be careful about the optical interface fringe etc. which degrades display quality.
- k) Do not expose the LCD panel to direct sunlight. Lightproof shade etc. should be attached when LCD panel is used under such environment
- l) Connect GND to frame of module to stabilize against EMI and external noise.
- m) If stored at the temperatures lower than the rated storage temperature, the LC may freeze and it may cause LCD panel damage. If storage temperature exceeds the specified rating, the molecular orientation of the LC may change to that of a liquid, and they may not revert to their original state. Store the module in normal room temperature.
- n) When handling LCD modules and assembling them into cabinets, please be avoid that long-term storage in the environment of oxidization or deoxidization gas and the use of such materials as reagent, solvent, adhesive, resin, etc. which generate these gasses, may cause corrosion and discoloration of the LCD modules.
- o) Liquid crystal contained in the panel may leak if the LCD is broken. Rinse it as soon as possible if it gets inside your eye or mouth by mistake.
- p) Notice:Never dismantle the module , because it will cause failure.  
Please don't remove the fixed tape, insulating tape etc that was pasted on the original module.  
(except for protection film of the panel and the crepe tape(yellow tape) of fixing lamp cable temporarily.)
- q) Be careful when using it for long time with fixed pattern display as it may cause afterimage.  
(Please use a screen saver etc., in order to avoid an afterimage. )
- r) If a minute particle enters in the module and adheres to an optical material, it may cause display non-uniformity issue, etc. Therefore, fine-pitch filters have to be installed to cooling and inhalation hole if you intend to install a fan.
- s) Take enough shielding countermeasure not to interfere to peripheral electronic device.
- t) The LED used for this product is very sensitive to the temperature. Luminance decreases rapidly when it is used for a long time under the environment of the high temperature.  
Please consult our company when it is used under the environment like the above mentioned.
- u) Epoxy resin (amine series curing agent), silicone adhesive material (dealcoholization series and oxime series), tray forming agent (azo compound) etc, in the cabinet or the packing materials may induce abnormal display with polarizer film deterioration regardless of contact or noncontact to polarizer film.  
Be sure to confirm the component of them.

## 12 Packing Form

12.1 Fig.4 shows packing form.

12.2 Carton stock conditions

- a) Maximum number of Carton being stuck: Max. 6 cartons
- b) Maximum number of product contained: 20 Unit
- c) Carton size: 571mm(W) × 241mm(H) × 356mm(D)
- d) Total mass (for 20Unit): Approximately 7.0 kg
- e) Carton stock environment:
  - 1) Temperature: 0 ~ 40°C
  - 2) Humidity: Up to 60%RH
  - 3) Ambiance: No gases bite into electronic components and wiring materials
  - 4) Period: Approximately 3month
  - 5) Unpacking: To prevent LCD module from damaging by ESD, unpack the module with effective measure after controlling humidity 50%RH or more.

## 13 Marking of product name

13.1. Serial No. indication.

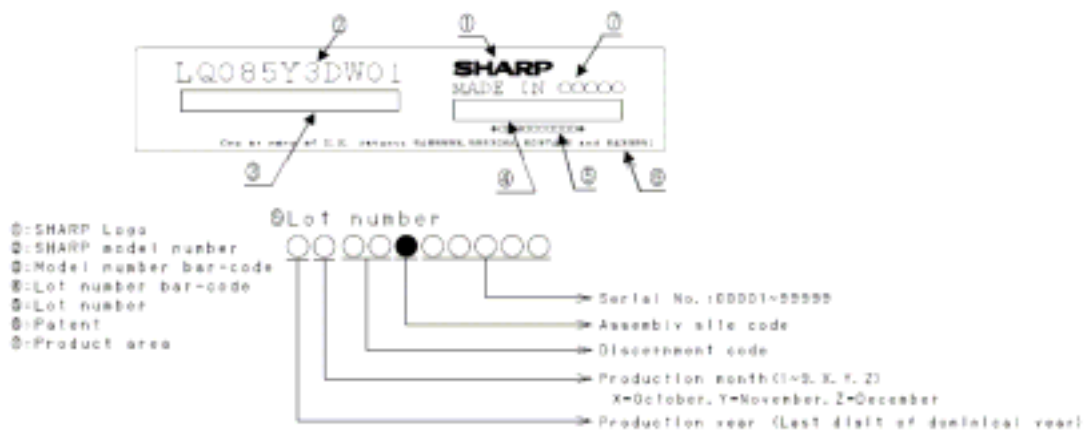

## 14 Reliability Test Items

[Note] Temperature condition is based on operating temperature condition of Absolute Maximum Ratings.

No.	Test parameter	Conditions
1	High temperature storage test	Leaves the module at Ta=60°C for 240h
2	Low temperature storage test	Leaves the module at Ta=-10°C for 240h
3	High temperature & high humidity operation test	Operates the module at Ta=40°C; 90~95%RH for 240h (No condensation)
4	High temperature operation test	Operates the module with +50°C at panel surface for 240h
5	Low temperature operation test	Operates the module at Ta=0°C for 240h (Exclude LED life time)
6	Shock test (non- operating)	Max. acceleration : 490m/s <sup>2</sup> Pulse width : 11ms, half sine wave Direction : ±X,±Y,±Z once for each direction.
7	Vibration test (non- operating)	Frequency : 10~57Hz/Vibration width (one side):0.076mm : 57~500Hz/ acceleration:9.8m/s <sup>2</sup> Sweep time : 11 minutes Test period :1 hour for each direction of X,Y,Z (total 3 hours)

[Result Evaluation Criteria]

Under the display quality test conditions with normal operation state, these shall be no change which may affect practical display function.

(normal operation state : Temperature:15 ~ 35°C, Humidity:45 ~ 75%, Atmospheric pressure:86 ~ 106kpa)

[Note] The directions of X, Y, Z are defined as below:

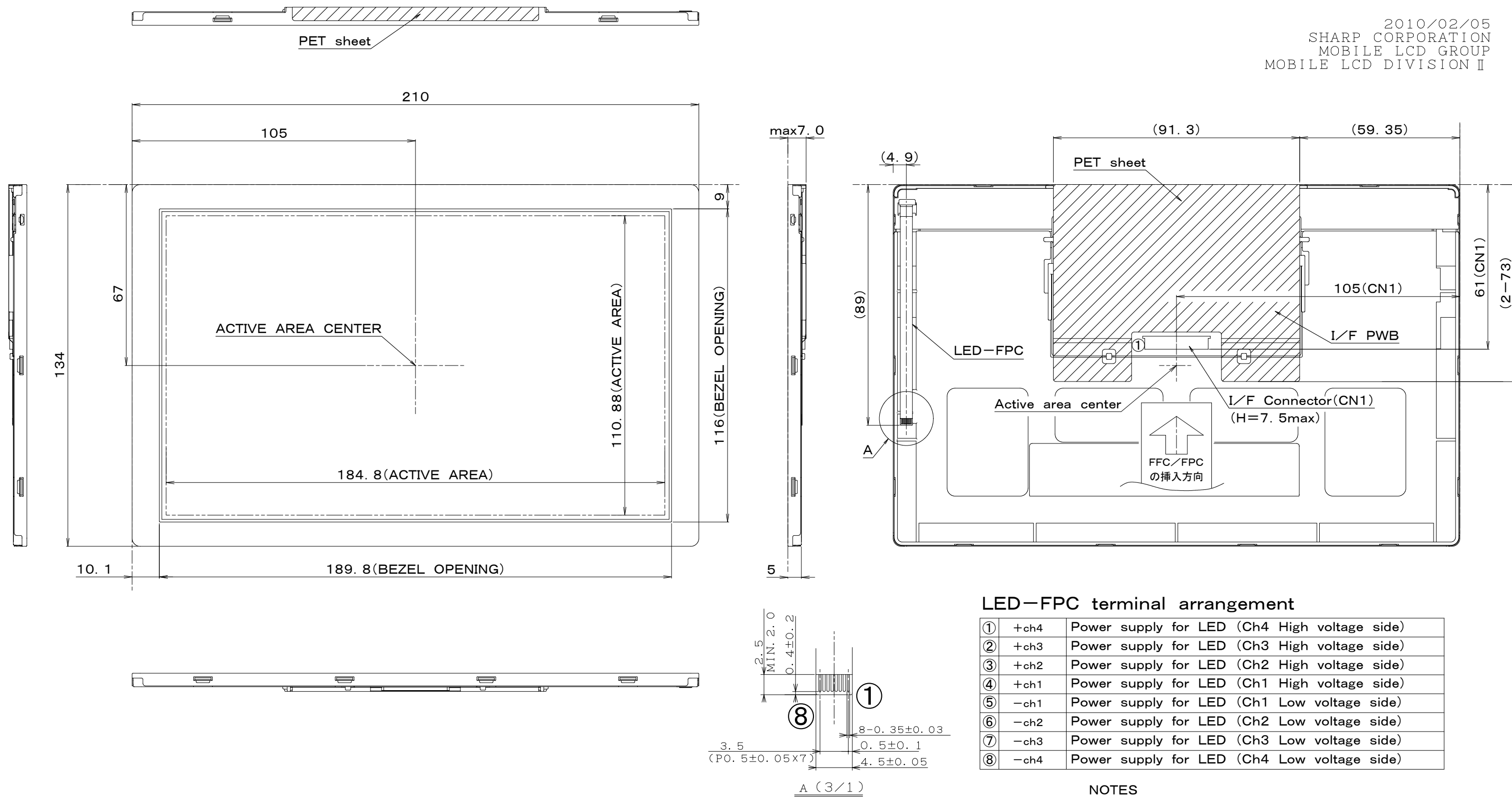

LED-FPC terminal arrangement

①	+ch4	Power supply for LED (Ch4 High voltage side)
②	+ch3	Power supply for LED (Ch3 High voltage side)
③	+ch2	Power supply for LED (Ch2 High voltage side)
④	+ch1	Power supply for LED (Ch1 High voltage side)
⑤	-ch1	Power supply for LED (Ch1 Low voltage side)
⑥	-ch2	Power supply for LED (Ch2 Low voltage side)
⑦	-ch3	Power supply for LED (Ch3 Low voltage side)
⑧	-ch4	Power supply for LED (Ch4 Low voltage side)

- NOTES
- UNSPECIFIED TOLERANCE TO BE ±0.3
  - WARP AND FLATING FOR PCB AND CHASSIS ARE EXCLUDED FROM THICKNESS AND DIMENSION OF THE UNIT.

Fig1 OUTLINE DIMENSIONS  
LQ085Y3DW01



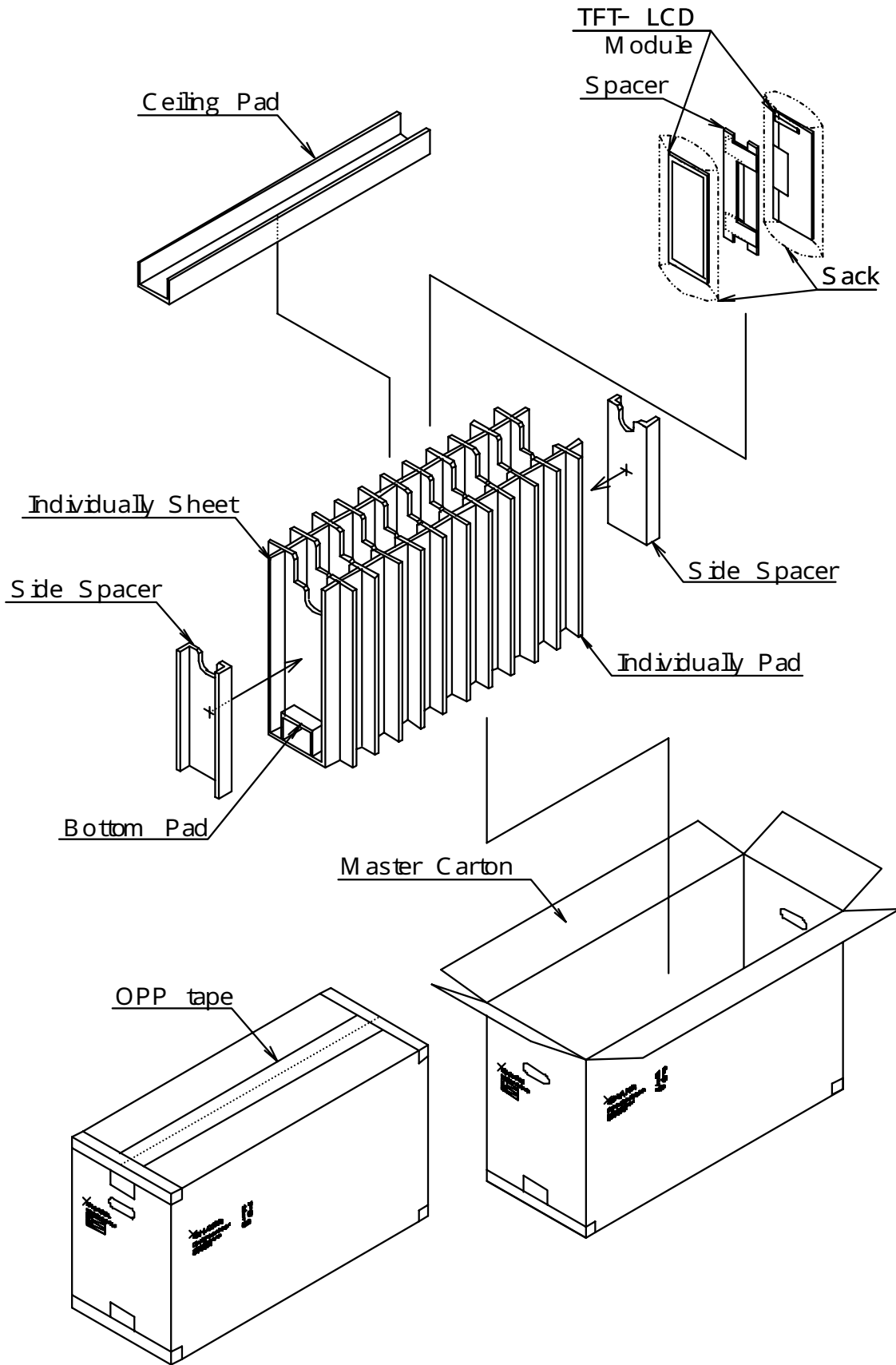

Fig4. Packing Form