



Chipsmall Limited consists of a professional team with an average of over 10 year of expertise in the distribution of electronic components. Based in Hongkong, we have already established firm and mutual-benefit business relationships with customers from,Europe,America and south Asia,supplying obsolete and hard-to-find components to meet their specific needs.

With the principle of “Quality Parts,Customers Priority,Honest Operation,and Considerate Service”,our business mainly focus on the distribution of electronic components. Line cards we deal with include Microchip,ALPS,ROHM,Xilinx,Pulse,ON,Everlight and Freescale. Main products comprise IC,Modules,Potentiometer,IC Socket,Relay,Connector.Our parts cover such applications as commercial,industrial, and automotives areas.

We are looking forward to setting up business relationship with you and hope to provide you with the best service and solution. Let us make a better world for our industry!



Contact us

Tel: +86-755-8981 8866 Fax: +86-755-8427 6832

Email & Skype: info@chipsmall.com Web: www.chipsmall.com

Address: A1208, Overseas Decoration Building, #122 Zhenhua RD., Futian, Shenzhen, China



LQ150X1LGN2A

TFT-LCD Module

Spec. Issue Date: Aug. 29, 2005

No: LD-16823

PREPARED BY : DATE	<p style="text-align: center;">SHARP</p> <p style="text-align: center;">Mobile Liquid Crystal Display GROUP SHARP CORPORATION</p> <p style="text-align: center;">SPECIFICATION</p>	SPEC No. LD-16823
APPROVED BY : DATE		FILE No.
		ISSUE : Aug.29.2005
		PAGE : 24 pages
		APPLICABLE GROUP Mobile Liquid Crystal Display Group

DEVICE SPECIFICATION

TFT-LCD Module

MODEL

LQ150X1LGN2A

These parts have corresponded with the RoHS directive.

CUSTOMER: SMA

CUSTOMER'S APPROVAL

DATE _____

BY _____

PRESENTED

BY *K. Shiono*

K.SHIONO
 Department General Manager
 Engineering Department 7
 MOBIL LCD DESIGN CENTER 1
 MOBIL LIQUID CRYSTAL DISPLAY GROUP
 SHARP Corporation

1. Application

This specification applies to the color 15.0 XGA TFT-LCD module LQ150X1LGN2A.

- ⊙ This specification are the proprietary product of SHARP CORPORATION("SHARP) and include materials protected under copyright of SHARP. Do not reproduce or cause any third party to reproduce them in any form or by any means, electronic or mechanical, for any purpose, in whole or in part, without the express written permission of SHARP.
- ⊙ The device listed in this technical literature was designed and manufactured for use in OA equipment.
- ⊙ In case of using the device for applications such as control and safety equipment for transportation(aircraft, trains, automobiles, etc.), rescue and security equipment and various safety related equipment which require higher reliability and safety, take into consideration that appropriate measures such as fail-safe functions and redundant system design should be taken.
- ⊙ Do not use the device for equipment that requires an extreme level of reliability, such as aerospace applications, telecommunication equipment(trunk lines), nuclear power control equipment and medical or other equipment for life support.
- ⊙ SHARP assumes no responsibility for any damage resulting from the use of the device which does not comply with the instructions and the precautions specified in these specification sheets.
- ⊙ Contact and consult with a SHARP sales representative for any questions about this device.

2. Overview

This module is a color active matrix LCD module incorporating amorphous silicon TFT (Thin Film Transistor). It is composed of a color TFT-LCD panel, driver ICs, control circuit, power supply circuit and a back light unit. Graphics and texts can be displayed on a 1024× RGB× 768 dots panel with about 16 million colors by using LVDS (Low Voltage Differential Signaling) and supplying +3.3V DC supply voltages for TFT-LCD panel driving and supply voltage for backlight.

3. Mechanical Specifications

Parameter	Specifications	Unit
Display size	38 (Diagonal)	cm
	15.0 (Diagonal)	Inch
Active area	304.1 (H)× 228.1 (V)	mm
Pixel format	1024 (H)× 768 (V)	Pixel
	(1 pixel = R+G+B dots)	
Pixel pitch	0.297 (H)× 0.297 (V)	mm
Pixel configuration	R, G, B vertical stripe	
Display mode	Normally white	
Unit outline dimensions *1	326.0(W)× 252.0(H)× 11.5(D)	mm
Mass	1100 (MAX)	g
Surface treatment	Anti-glare and hard-coating 2H (Haze value = 28)	

*1.Note: excluding back light cables, cover and pet sheet.

The thickness of module (D) doesn't contain the projection.

Outline dimensions are shown in Fig.1.

4. Input Terminals

4-1. TFT-LCD panel driving

CN1 (Interface signals and +3.3V DC power supply)

Using connectors : DF14H-20P-1.25H (Hirose Electric Co., Ltd.)

Corresponding connectors : DF14-20S-1.25C(Connector)
DF14-2628SCFA(Terminal)

Corresponding LVDS Transmitter : THC63LVDM83R(Thine) or compatible

Pin No.	Symbol	Function	Remark
1	Vcc	+3.3V Power supply	
2	Vcc	+3.3V Power supply	
3	GND		
4	GND		
5	RXIN0-	Receiver signal (-)	LVDS
6	RXIN0+	Receiver signal (+)	LVDS
7	GND		
8	RXIN1-	Receiver signal (-)	LVDS
9	RXIN1+	Receiver signal (+)	LVDS
10	GND		
11	RXIN2-	Receiver signal (-)	LVDS
12	RXIN2+	Receiver signal (+)	LVDS
13	GND		
14	RXCKIN-	Clock signal (-)	LVDS
15	RXCKIN+	Clock signal (+)	LVDS
16	GND		
17	RXIN3-	Receiver signal (-)	LVDS
18	RXIN3+	Receiver signal (+)	LVDS
19	GND		
20	LVDS_SET	LVDS_SET	【note1】

4-2 Data Mapping

1) 8 bit input

【note1】 pin assignment with LVDS_SET pin (Thine:THC63LVDM83R)

Transmitter		20pin LVDS_SET	
Pin No	Data	=L (GND) or Open	=H (3.3V)
51	TA0	R2	R0 (LSB)
52	TA1	R3	R1
54	TA2	R4	R2
55	TA3	R5	R3
56	TA4	R6	R4
3	TA5	R7 (MSB)	R5
4	TA6	G2	G0 (LSB)
6	TB0	G3	G1
7	TB1	G4	G2
11	TB2	G5	G3
12	TB3	G6	G4
14	TB4	G7 (MSB)	G5
15	TB5	B2	B0 (LSB)
19	TB6	B3	B1
20	TC0	B4	B2
22	TC1	B5	B3
23	TC2	B6	B4
24	TC3	B7 (MSB)	B5
27	TC4	(NA)	(NA)
28	TC5	(NA)	(NA)
30	TC6	DE	DE
50	TD0	R0 (LSB)	R6
2	TD1	R1	R7 (MSB)
8	TD2	G0 (LSB)	G6
10	TD3	G1	G7 (MSB)
16	TD4	B0 (LSB)	B6
18	TD5	B1	B7 (MSB)
25	TD6	(NA)	(NA)

<LVDS_SET=L or Open>

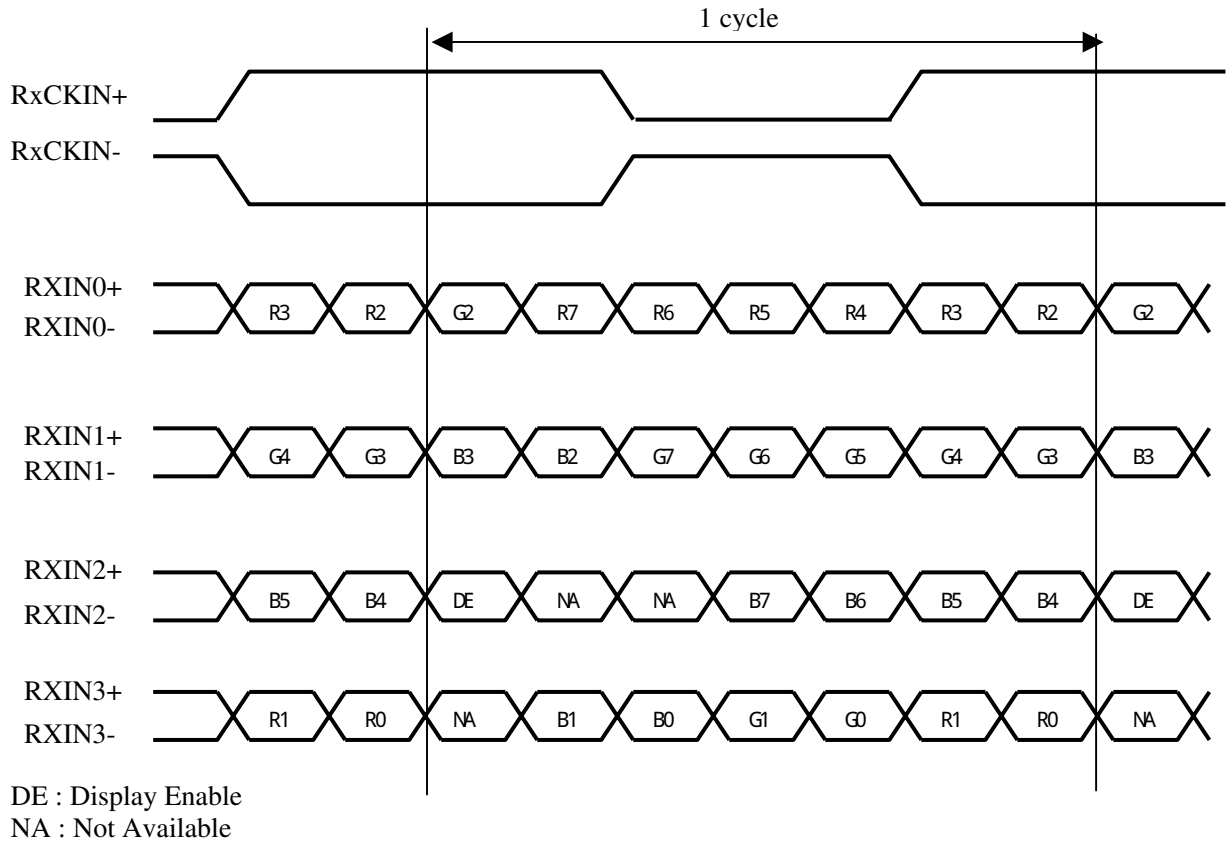

<LVDS_SET =H>

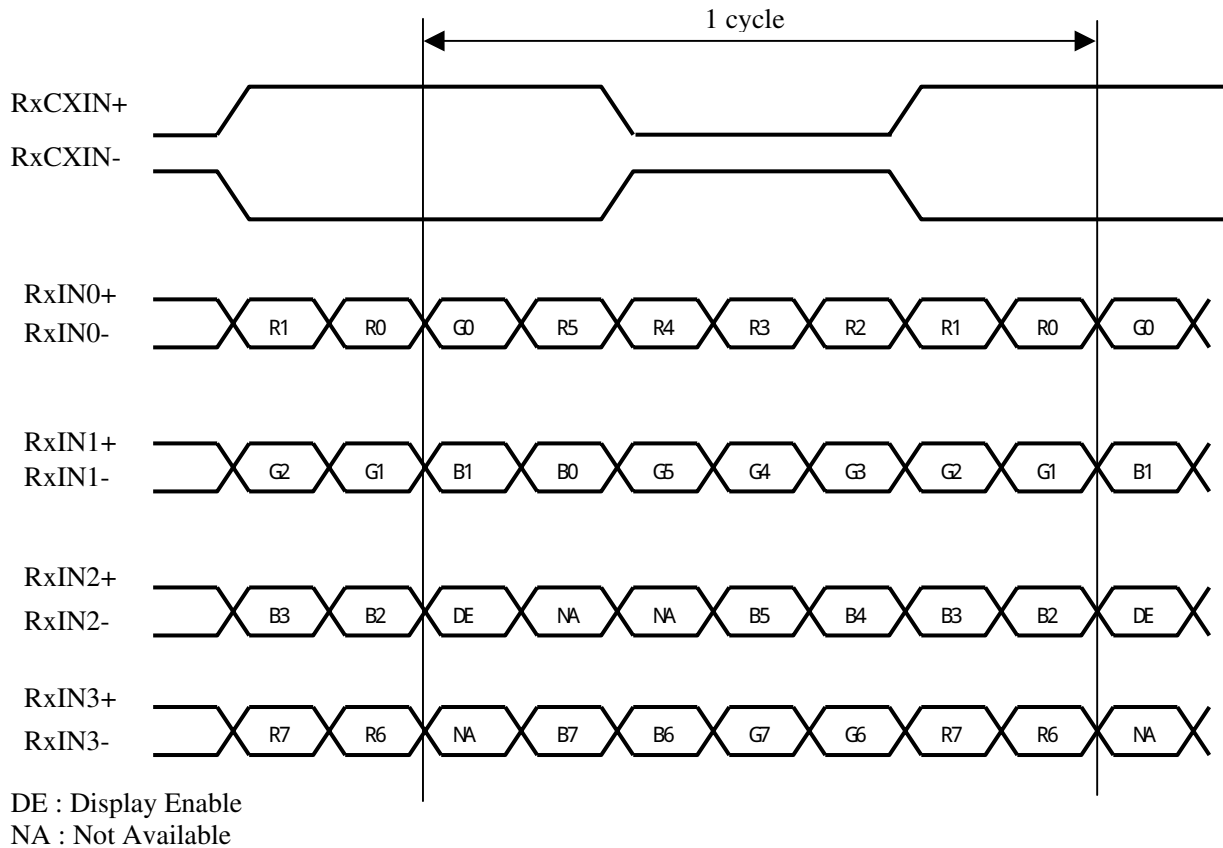

2) 6 bit input

【note1】 pin assignment with LVDS_SET pin (Thine:THC63LVDM83R)

Transmitter		20pin LVDS_SET	
Pin No	Data	=L (GND) or Open	=H (3.3V)
51	TA0	R0 (LSB)	-
52	TA1	R1	-
54	TA2	R2	-
55	TA3	R3	-
56	TA4	R4	-
3	TA5	R5 (MSB)	-
4	TA6	G0 (LSB)	-
6	TB0	G1	-
7	TB1	G2	-
11	TB2	G3	-
12	TB3	G4	-
14	TB4	G5 (MSB)	-
15	TB5	B0 (LSB)	-
19	TB6	B1	-
20	TC0	B2	-
22	TC1	B3	-
23	TC2	B4	-
24	TC3	B5 (MSB)	-
27	TC4	(NA)	-
28	TC5	(NA)	-
30	TC6	DE	-
50	TD0	GND	-
2	TD1	GND	-
8	TD2	GND	-
10	TD3	GND	-
16	TD4	GND	-
18	TD5	GND	-
25	TD6	(NA)	-

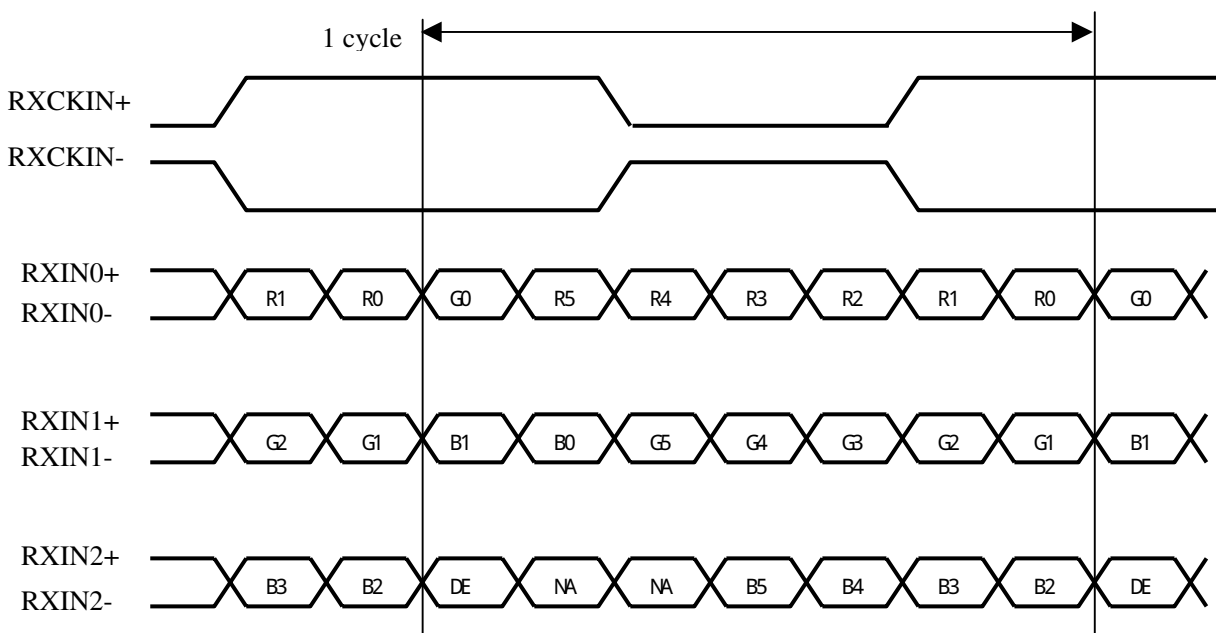

DE : Display Enable

NA : Not Available

※ In case of supplying 6 bit signal, it is recommended to connect pin No.17(Rx3-) with VCC(3.3V), and No.18(Rx3+) with GND(0V).

(Computer Side)

(TFT-LCD side)

① 8Bit Mode

LVDS_SET=H (20 pin=3.3[V])

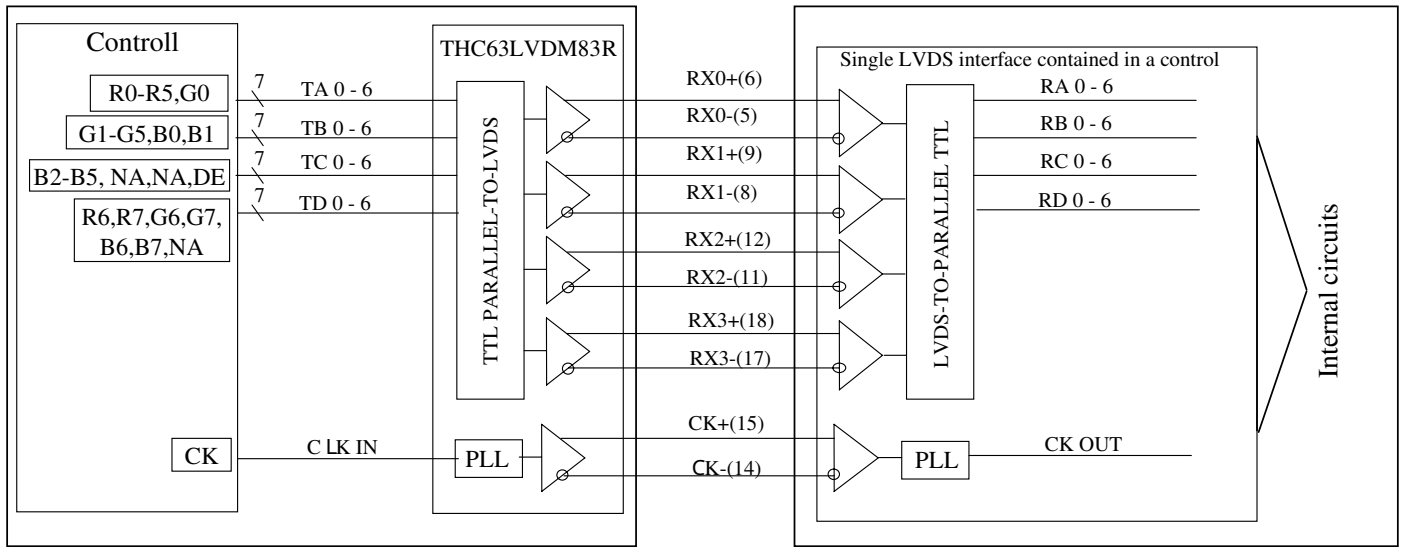

② 8Bit Mode

LVDS_SET=L (20 pin=GND or OPEN)

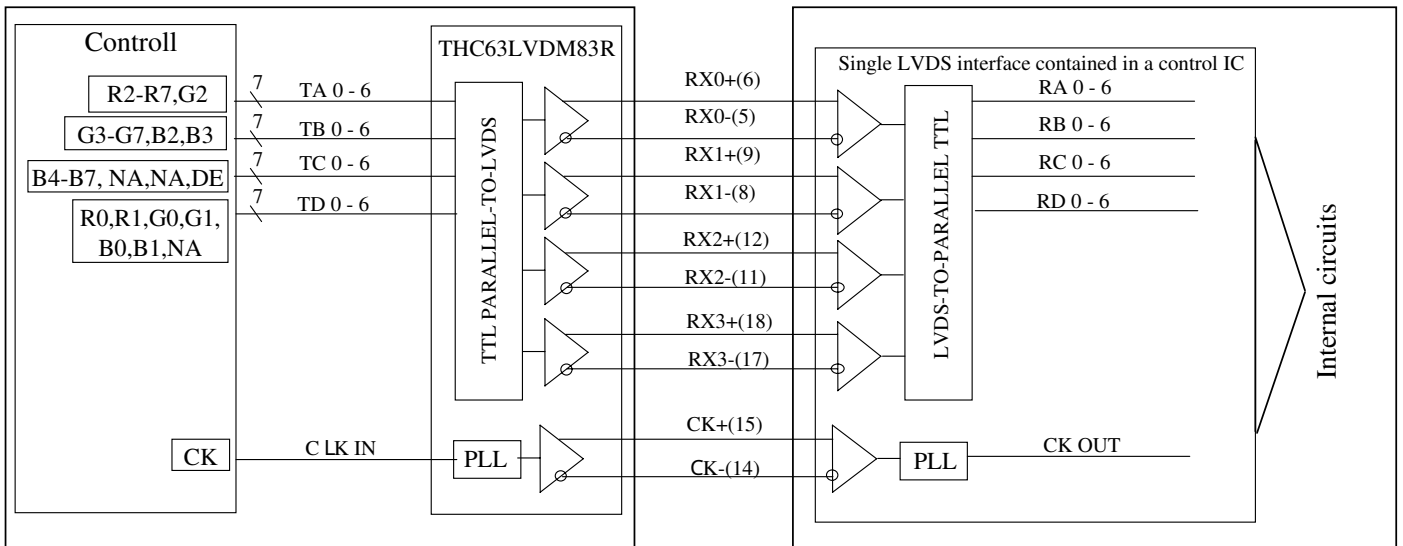

③ 6Bit Mode

LVDS_SET=L (20 pin=GND or OPEN)

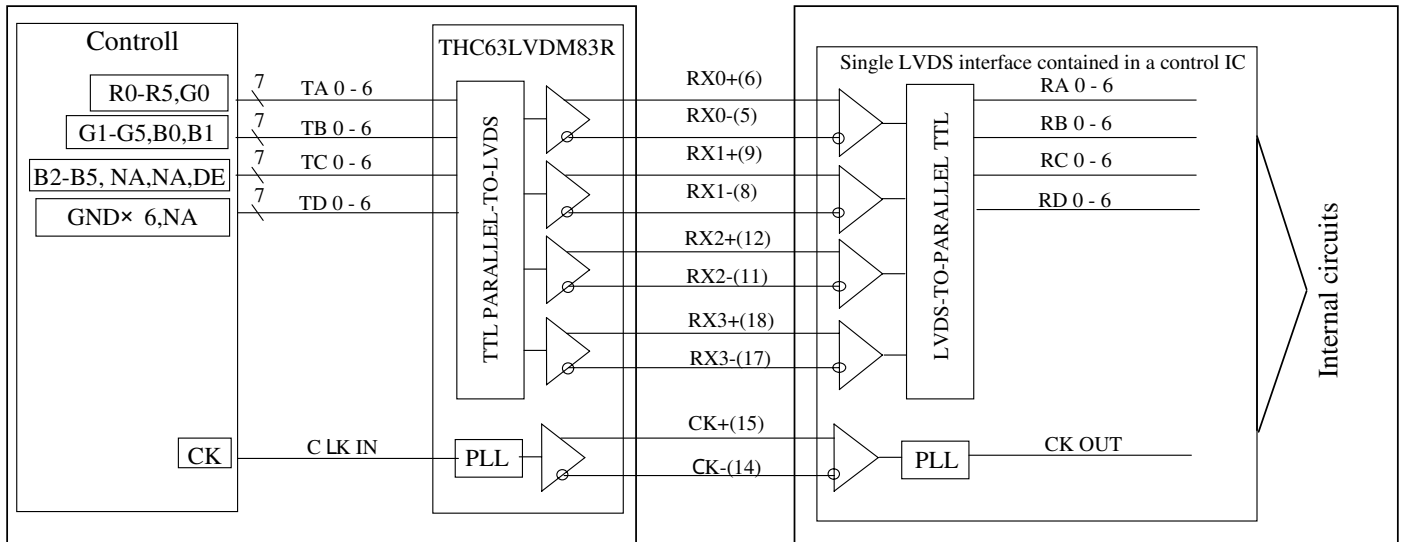

4-4 Backlight

CN 2, 3

The module-side connector : BHSR-02VS-1 (JST)

The user-side connector : SM02B-BHSS-1-TB (JST)

Pin no.	symbol	I/O	Function
1	V _{HIGH}	I	Power supply for lamp (High voltage side)
2	V _{LOW}	I	Power supply for lamp (Low voltage side)

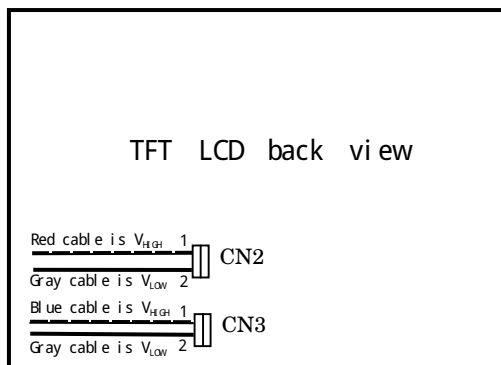

5. Absolute Maximum Ratings

Parameter	Symbol	Condition	Ratings	Unit	Remark
Supply voltage	V _{CC}	T _a =25°C	0 ~ +4.0	V	
Lamp Input voltage	V _{HIGH}	-	0 ~ +2700	V _{rms}	
Storage temperature	T _{STG}	-	-25 ~ +60	°C	【Note1】
Operating temperature	T _{OPA}	-	0 ~ +50	°C	

【Note1】 Humidity : 95%RH Max. (T_a ≤ 40°C)

Maximum wet-bulb temperature at 39°C or less. (T_a>40°C)

No condensation.

6. Electrical Characteristics

6-1. TFT-LCD panel driving

Ta = 25°C

Parameter		Symbol	Min.	Typ.	Max.	Unit	Remark
Vcc	Supply voltage	Vcc	+3.0	+3.3	+3.6	V	【Note2】
	Current dissipation	Icc	-	425	700	mA	【Note3】
Permissible input ripple voltage		V _{RF}	-	-	100	mVp-p	V _{CC} =+3.3V
Differential input threshold voltage	High	V _{TH}	-	-	+100	mV	V _{CM} =+1.2V 【Note1】
	Low	V _{TL}	-100	-	-	mV	
Input current (High)		I _{OH}	-	-	± 10	μ A	V _I =2.4V, V _{CC} =3.6V
Input current (Low)		I _{OL}	-	-	± 10	μ A	V _I =0V, V _{CC} =3.6V
Terminal resistor		R _T	-	100	-	Ω	Differential input

【Note1】 V_{CM} : Common mode voltage of LVDS driver.

【Note2】

1) On-off sequences of Vcc and data

- 0 < t1 ≤ 10ms
- 0 < t2 ≤ 10ms
- 0 < t3 ≤ 1s
- 1s ≤ t4
- 200ms ≤ t5

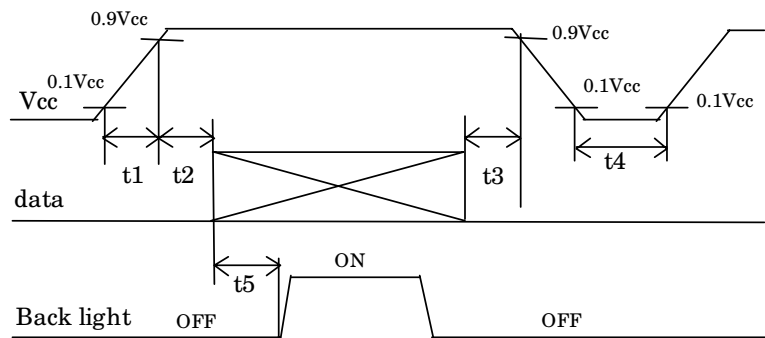

Power sequence for Backlight is not especially specified, however it is recommended to consider some timing difference between LVDS input and Backlight input as shown above.

If the Backlight lights on before LCD starting, or if the Backlight is kept on after LCD stopping, the screen may look white for a moment or abnormal image may be displayed.

This is caused by variation in output signal from timing generator at LVDS input on or off. It does not cause the damage to the LCD module.

2) Dip conditions for supply voltage

- 1) V2 ≤ Vcc < V1
td ≤ 10ms
- 2) Vcc < V2
Vcc-dip conditions should also follow the on-off conditions.

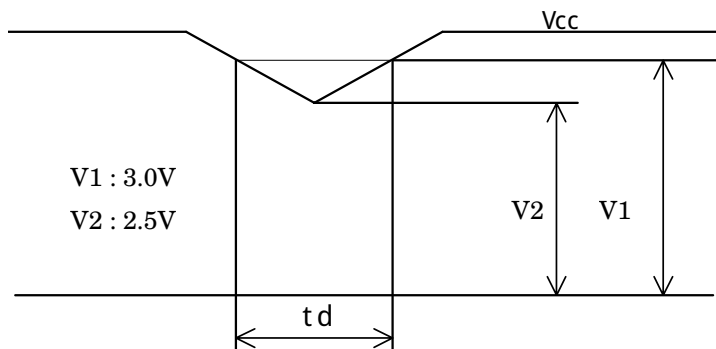

【Note3】 Typical current situation : 16-gray-bar pattern

Vcc=+3.3V, CK=65MHz

Horizontal period =20.7 us

Gray scale : GS(4n)

n=0 ~ 15

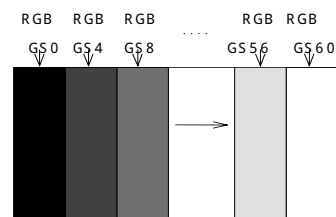

The explanation of each gray scale, GS(4n), is described below section 8-2.

6-2. Backlight

The back light system is an edge-lighting type with 2 CCFTs (Cold Cathode Fluorescent Tube).

The characteristics of the lamp are shown in the following table.

The value mentioned below is at the case of one CCFT.

CCFT Model Name : KTBE24MSTF-530.5KB270-Z-L (STANLEY ELECTRIC CO.,LTD)

Parameter	Symbol	Min.	Typ.	Max.	Unit	Remark
Lamp current range	I_L	3.0	4.5	5.0	mArms	【Note1】
Lamp voltage	V_L	-	1000	1150	Vrms	$I_L=4.5$ mArms $T_a=25^\circ\text{C}$ 60kHz
Lamp power consumption	P_L	-	4.5	5.2	W	【Note2】 $I_L=4.5$ mArms $T_a=25^\circ\text{C}$ 60kHz
Lamp frequency	F_L	40	60	70	kHz	【Note3】
Kick-off voltage	V_s	-	-	2200	Vrms	$T_a=0^\circ\text{C}$ 60kHz 【Note4】
Lamp life time	T_L	50,000	-	-	hour	【Note5】

【Note1】 A lamp can be light in the range of lamp current shown above.

Maximum rating for current is measured by high frequency current measurement equipment connected to V_{LOW} at circuit showed below.

(Note : To keep enough kick-off voltage and necessary steady voltage for CCFT.)

Lamp frequency : 40 ~ 70kHz

Ambient temperature : 0 ~ 50°C

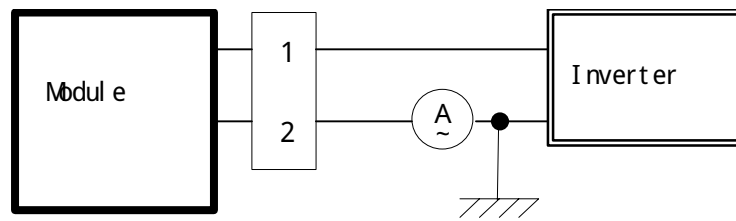

【Note2】 Referential data per one CCFT by calculation ($I_L \times V_L$).

The data don't include loss at inverter.

【Note3】 Lamp frequency of inverter may produce interference with horizontal synchronous frequency, and this may cause horizontal beat on the display. Therefore, adjust lamp frequency, and keep inverter as far as from module or use electronic shielding between inverter and module to avoid interference.

【Note4】 This is transformer output voltage at 33pF for the ballast capacitor of a DC-AC inverter.

The kick-off voltage may rise up in the user set, please decide the open output voltage by checking not to occur lighting failure under operating state.

The open output voltage should be applied to the lamp for more than 1 second to startup. Otherwise the lamp may not be turned on.

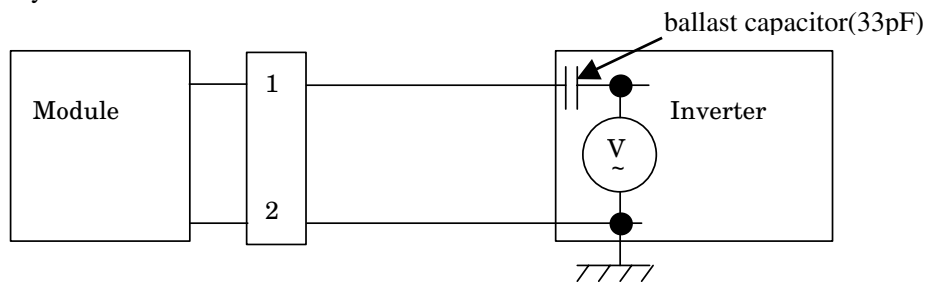

* 2pin V_{LOW}

【Note5】 Lamp life time is defined as the time when either ① or ② occurs in the continuous operation under the condition of $T_a=25^{\circ}\text{C}$ and $I_L=5.0\text{ mA rms}$.

① Brightness becomes 50% of the original value under standard condition.

② Kick-off voltage at $T_a=0^{\circ}\text{C}$ exceeds $2200\text{ V}_{\text{rms}}$ value.

《Note》

The performance of the backlight, for example lifetime or brightness, is much influenced by the characteristics of the DC-AC inverter for the lamp. When you design or order the inverter, please make sure that a poor lighting caused by the mismatch of the backlight and the inverter (miss-lighting, flicker, etc.) never occurs. When you confirm it, the module should be operated in the same condition as it is installed in your instrument.

Use the lamp inverter power source incorporating such safeguard as overvoltage / overcurrent protective circuit or lamp voltage waveform detection circuit, which should have individual control of each lamp.

In case one circuit without such individual control is connected to more than two lamps, excessive current may flow into one lamp when the other one is not in operation.

7. Timing characteristics of input signals

7-1. Timing characteristics

Parameter		Symbol	Min.	Typ.	Max.	Unit
Clock signal	Frequency	$1/T_c$	50.0	65.0	80.0	MHz
ENAB signal	Horizontal period	TH	1056	1344	1720	clock
			16.0	20.7	23.4	μs
	Horizontal period (High)	THd	1024	1024	1024	clock
	Vertical period	TV	773	806	990	line
	Vertical period (High)	TVd	768	768	768	line

【Note】 In case of using the long vertical period, the deterioration of display quality, flicker etc. may occur.

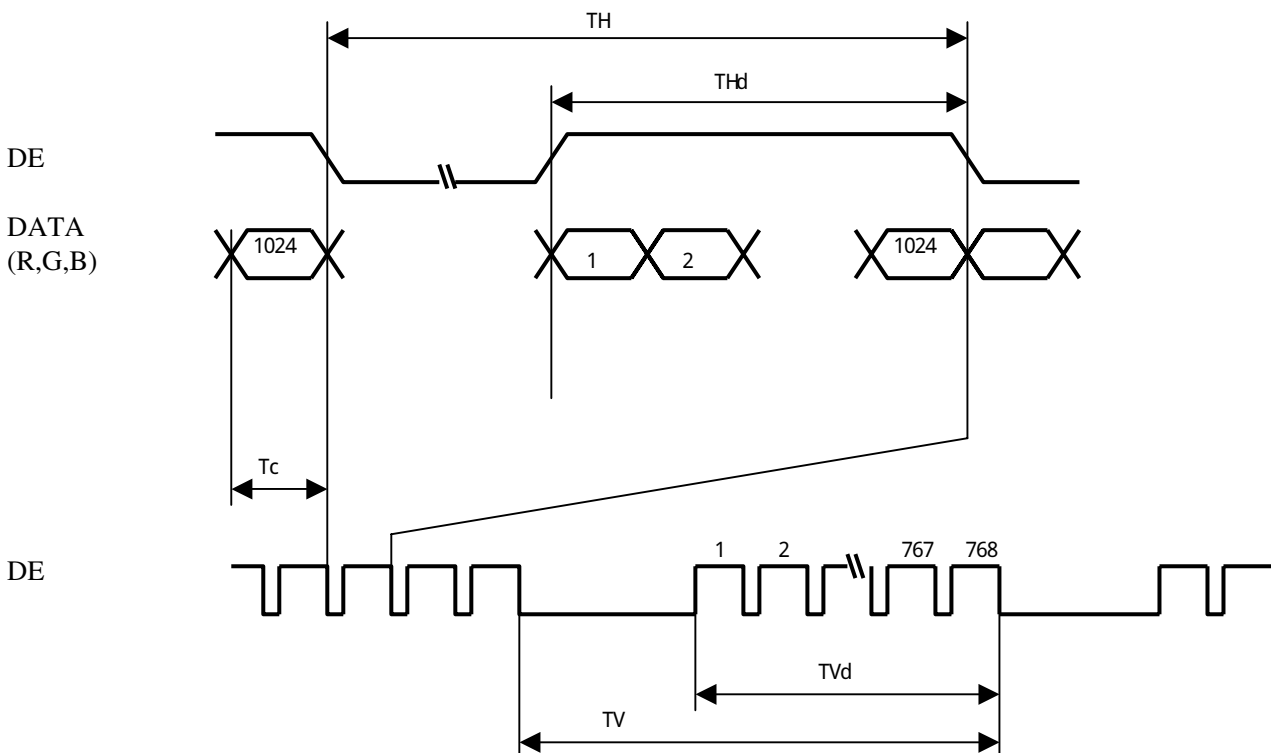

7-2 Input Data Signals and Display Position on the screen

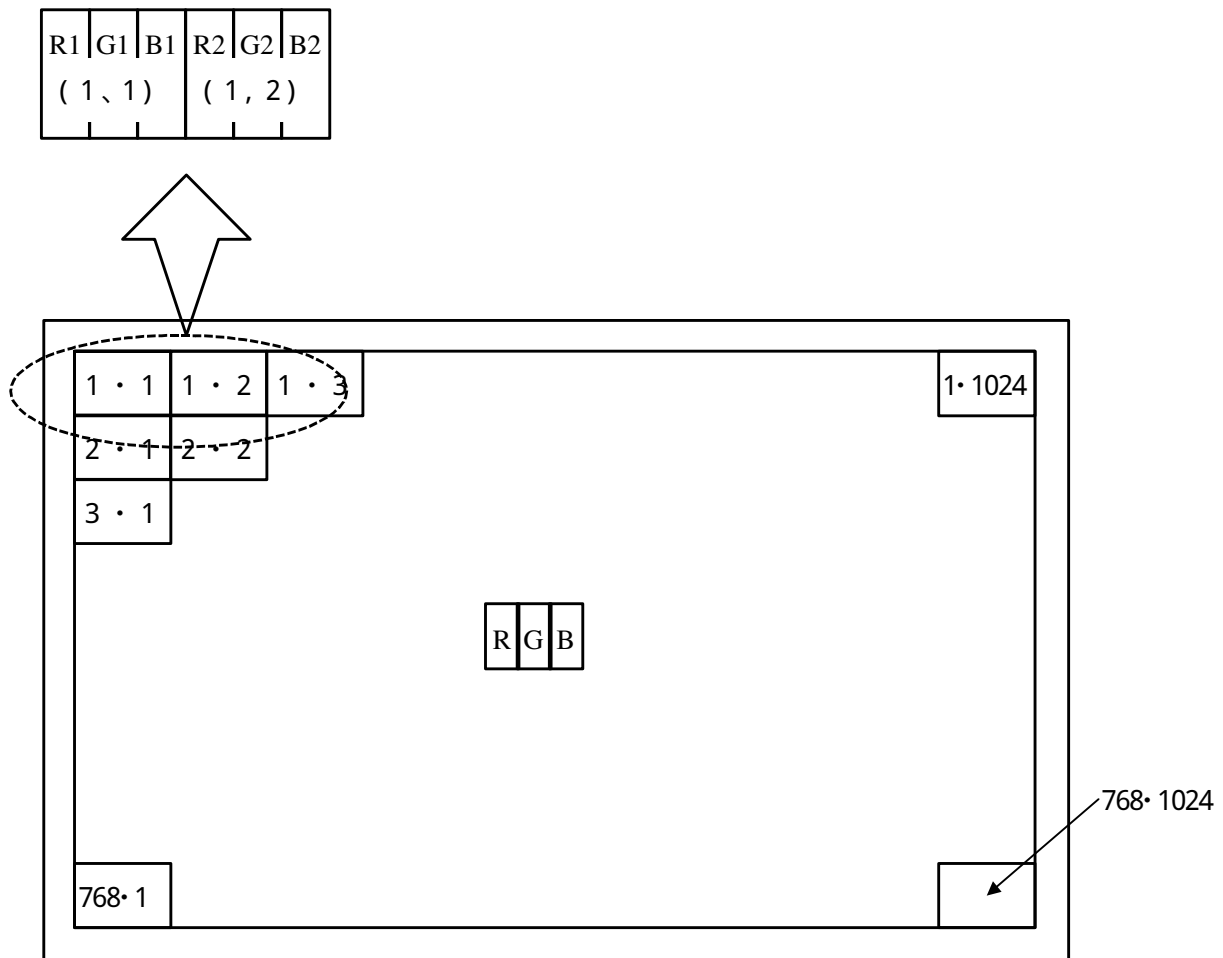

Display Position of Data (V, H)

8. Input Signals, Basic Display Colors and Gray Scale of Each Color

8-1 8bit input

	Colors & Gray scale	Gray Scale	Data signal																							
			R0	R1	R2	R3	R4	R5	R6	R7	G0	G1	G2	G3	G4	G5	G6	G7	B0	B1	B2	B3	B4	B5	B6	B7
Basic Color	Black	-	0	0	0	0	0	0	0	0	0	0	0	0	0	0	0	0	0	0	0	0	0	0	0	0
	Blue	-	0	0	0	0	0	0	0	0	0	0	0	0	0	0	0	0	X	X	1	1	1	1	1	1
	Green	-	0	0	0	0	0	0	0	0	X	X	1	1	1	1	1	1	0	0	0	0	0	0	0	0
	Cyan	-	0	0	0	0	0	0	0	0	X	X	1	1	1	1	1	1	X	X	1	1	1	1	1	1
	Red	-	X	X	1	1	1	1	1	1	0	0	0	0	0	0	0	0	0	0	0	0	0	0	0	0
	Magenta	-	X	X	1	1	1	1	1	1	0	0	0	0	0	0	0	0	X	X	1	1	1	1	1	1
	Yellow	-	X	X	1	1	1	1	1	1	X	X	1	1	1	1	1	1	0	0	0	0	0	0	0	0
	White	-	X	X	1	1	1	1	1	1	X	X	1	1	1	1	1	1	X	X	1	1	1	1	1	1
Gray Scale of Red	Black	GS0	0	0	0	0	0	0	0	0	0	0	0	0	0	0	0	0	0	0	0	0	0	0	0	0
	↑	GS1	1	0	0	0	0	0	0	0	0	0	0	0	0	0	0	0	0	0	0	0	0	0	0	0
	Darker	GS2	0	1	0	0	0	0	0	0	0	0	0	0	0	0	0	0	0	0	0	0	0	0	0	0
	↑	↓					↓							↓								↓				
	↓	↓					↓							↓								↓				
	Brighter	GS250	0	1	0	1	1	1	1	1	0	0	0	0	0	0	0	0	0	0	0	0	0	0	0	0
	↓	GS251	1	1	0	1	1	1	1	1	0	0	0	0	0	0	0	0	0	0	0	0	0	0	0	0
	Red	GS252	X	X	1	1	1	1	1	1	0	0	0	0	0	0	0	0	0	0	0	0	0	0	0	0
Gray Scale of Green	Black	GS0	0	0	0	0	0	0	0	0	0	0	0	0	0	0	0	0	0	0	0	0	0	0	0	0
	↑	GS1	0	0	0	0	0	0	0	0	1	0	0	0	0	0	0	0	0	0	0	0	0	0	0	0
	Darker	GS2	0	0	0	0	0	0	0	0	0	1	0	0	0	0	0	0	0	0	0	0	0	0	0	0
	↑	↓					↓							↓								↓				
	↓	↓					↓							↓								↓				
	Brighter	GS250	0	0	0	0	0	0	0	0	0	1	0	1	1	1	1	1	0	0	0	0	0	0	0	0
	↓	GS251	0	0	0	0	0	0	0	0	1	1	0	1	1	1	1	1	0	0	0	0	0	0	0	0
	Green	GS252	0	0	0	0	0	0	0	0	X	X	1	1	1	1	1	1	0	0	0	0	0	0	0	0
Gray Scale of Blue	Black	GS0	0	0	0	0	0	0	0	0	0	0	0	0	0	0	0	0	0	0	0	0	0	0	0	0
	↑	GS1	0	0	0	0	0	0	0	0	0	0	0	0	0	0	0	0	1	0	0	0	0	0	0	0
	Darker	GS2	0	0	0	0	0	0	0	0	0	0	0	0	0	0	0	0	0	1	0	0	0	0	0	0
	↑	↓					↓							↓								↓				
	↓	↓					↓							↓								↓				
	Brighter	GS250	0	0	0	0	0	0	0	0	0	0	0	0	0	0	0	0	0	1	0	1	1	1	1	1
	↓	GS251	0	0	0	0	0	0	0	0	0	0	0	0	0	0	0	0	1	1	0	1	1	1	1	1
	Blue	GS252	0	0	0	0	0	0	0	0	0	0	0	0	0	0	0	0	X	X	1	1	1	1	1	1

0 : Low level voltage, 1 : High level voltage. X :Don't care.

Each basic color can be displayed in 253 gray scales from 8 bit data signals. According to the combination of total 24 bit data signals, the 16-million-color display can be achieved on the screen.

8-2 6bit input

	Colors & Gray scale	Data signal																		
		Gray Scale	R0	R1	R2	R3	R4	R5	G0	G1	G2	G3	G4	G5	B0	B1	B2	B3	B4	B5
Basic Color	Black	-	0	0	0	0	0	0	0	0	0	0	0	0	0	0	0	0	0	0
	Blue	-	0	0	0	0	0	0	0	0	0	0	0	0	1	1	1	1	1	1
	Green	-	0	0	0	0	0	0	1	1	1	1	1	1	0	0	0	0	0	0
	Cyan	-	0	0	0	0	0	0	1	1	1	1	1	1	1	1	1	1	1	1
	Red	-	1	1	1	1	1	1	0	0	0	0	0	0	0	0	0	0	0	0
	Magenta	-	1	1	1	1	1	1	0	0	0	0	0	0	1	1	1	1	1	1
	Yellow	-	1	1	1	1	1	1	1	1	1	1	1	1	0	0	0	0	0	0
	White	-	1	1	1	1	1	1	1	1	1	1	1	1	1	1	1	1	1	1
Gray Scale of Red	Black	GS0	0	0	0	0	0	0	0	0	0	0	0	0	0	0	0	0	0	0
	↑	GS1	1	0	0	0	0	0	0	0	0	0	0	0	0	0	0	0	0	0
	Darker	GS2	0	1	0	0	0	0	0	0	0	0	0	0	0	0	0	0	0	0
	↑	↓			↓					↓					↓					
	↓	↓			↓					↓					↓					
	Brighter	GS61	1	0	1	1	1	1	0	0	0	0	0	0	0	0	0	0	0	0
	↓	GS62	0	1	1	1	1	1	0	0	0	0	0	0	0	0	0	0	0	0
	Red	GS63	1	1	1	1	1	1	0	0	0	0	0	0	0	0	0	0	0	0
Gray Scale of Green	Black	GS0	0	0	0	0	0	0	0	0	0	0	0	0	0	0	0	0	0	0
	↑	GS1	0	0	0	0	0	0	1	0	0	0	0	0	0	0	0	0	0	0
	Darker	GS2	0	0	0	0	0	0	0	1	0	0	0	0	0	0	0	0	0	0
	↑	↓			↓					↓					↓					
	↓	↓			↓					↓					↓					
	Brighter	GS61	0	0	0	0	0	0	1	0	1	1	1	1	0	0	0	0	0	0
	↓	GS62	0	0	0	0	0	0	0	1	1	1	1	1	0	0	0	0	0	0
	Green	GS63	0	0	0	0	0	0	1	1	1	1	1	1	0	0	0	0	0	0
Gray Scale of Blue	Black	GS0	0	0	0	0	0	0	0	0	0	0	0	0	0	0	0	0	0	0
	↑	GS1	0	0	0	0	0	0	0	0	0	0	0	0	1	0	0	0	0	0
	Darker	GS2	0	0	0	0	0	0	0	0	0	0	0	0	0	1	0	0	0	0
	↑	↓			↓					↓					↓					
	↓	↓			↓					↓					↓					
	Brighter	GS61	0	0	0	0	0	0	0	0	0	0	0	0	1	0	0	1	1	1
	↓	GS62	0	0	0	0	0	0	0	0	0	0	0	0	0	1	1	1	1	1
	Blue	GS63	0	0	0	0	0	0	0	0	0	0	0	0	1	1	1	1	1	1

0 : Low level voltage, 1 : High level voltage.

Each basic color can be displayed in 64 gray scales from 6 bit data signals. According to the combination of total 18 bit data signals, the 262,144-color display can be achieved on the screen.

9. Optical Characteristics

Ta=25°C, Vcc =+3.3V

Parameter		Symbol	Condition	Min.	Typ.	Max.	Unit	Remark		
Viewing angle range	Vertical	θ_{11}	$CR \geq 5$	40	55	-	Deg.	【Note1,4】		
		θ_{12}		70	80	-	Deg.			
	Horizontal	θ_{21}, θ_{22}		70	80	-	Deg.			
	Vertical	θ_{11}	$CR \geq 10$	30	45	-	Deg.			
		θ_{12}		45	55	-	Deg.			
	Horizontal	θ_{21}, θ_{22}		50	60	-	Deg.			
Contrast ratio		C R	$\theta = 0^\circ$	250	350	-		【Note2,4】		
Response Time	Rise	γ_r	$\theta = 0^\circ$	-	5	20	ms	【Note3,4】		
	Fall	γ_d		-	20	40	ms			
Chromaticity of White		x	$\theta = 0^\circ$	0.283	0.313	0.343		【Note4】		
		y		0.299	0.329	0.359				
Chromaticity of Red		x		0.551	0.581	0.611				
		y		0.292	0.322	0.352				
Chromaticity of Green		x		0.277	0.307	0.337				
		y		0.516	0.546	0.576				
Chromaticity of Blue		x		0.121	0.151	0.181				
		y		0.097	0.127	0.157				
Luminance of white		Y_L			200	260	-		cd/m ²	IL=4.5mA rms fL=60kHz 【Note4】
White Uniformity		δ_w			-	-	1.25		-	【Note5】

※ The measurement shall be executed 30 minutes after lighting at rating.

The optical characteristics shall be measured in a dark room or equivalent state with the method shown in Fig.2 below.

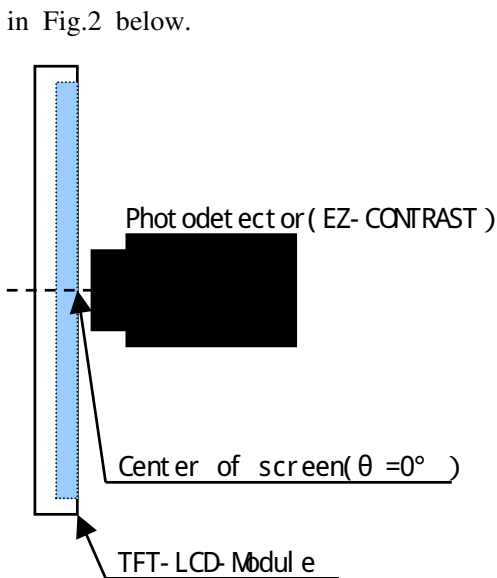

Fig2-1 Viewing angle measurement method

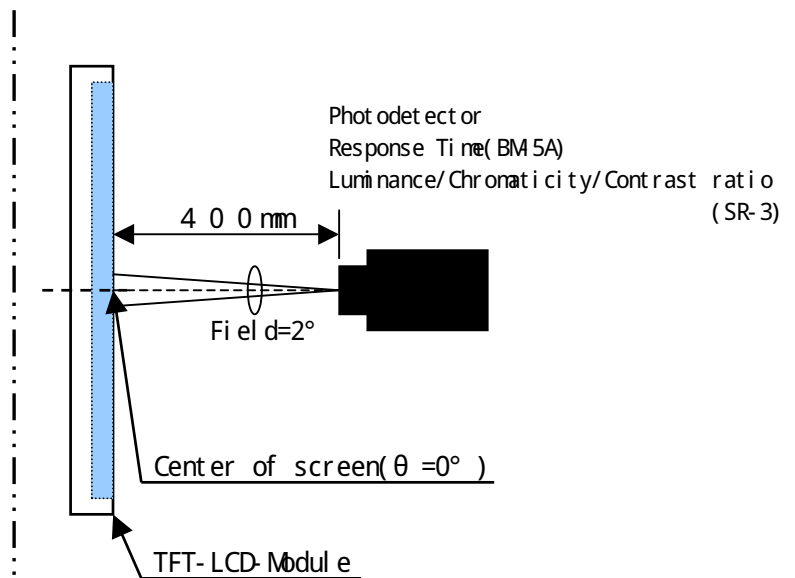
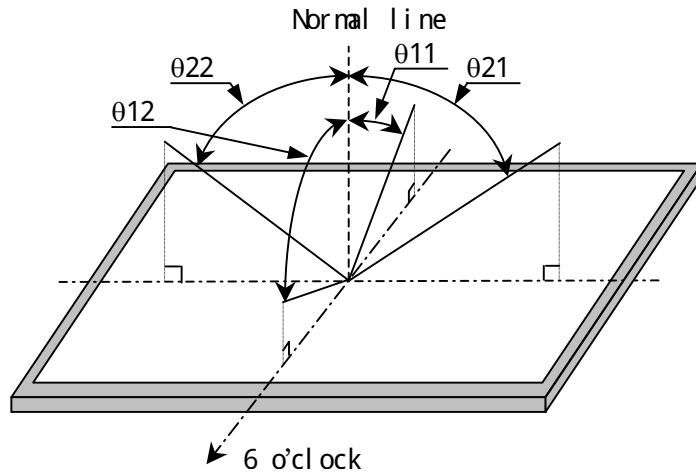

Fig2-2 Luminance/Contrast ratio/Response time/Chromaticity measurement method

【Note1】 Definitions of viewing angle range:



【Note2】 Definition of contrast ratio:

The contrast ratio is defined as the following.

$$\text{Contrast Ratio (CR)} = \frac{\text{Luminance (brightness) with all pixels white}}{\text{Luminance (brightness) with all pixels black}}$$

【Note3】 Definition of response time:

The response time is defined as the following figure and shall be measured by switching the input signal for "black" and "white".

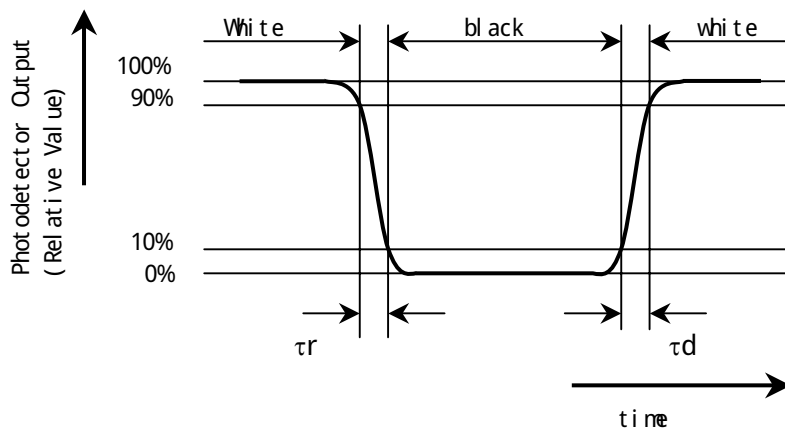

【Note4】 This shall be measured at center of the screen.

【Note5】 Definition of white uniformity:

White uniformity is defined as the following with five measurements (A ~ E).

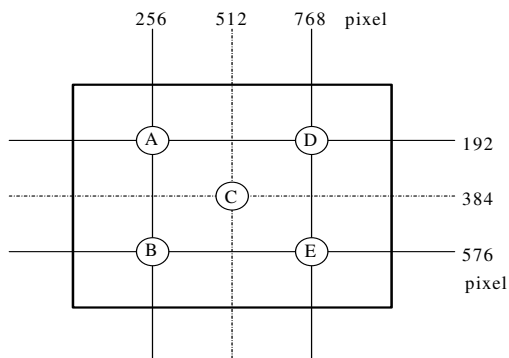

$$\delta w = \frac{\text{Maximum Luminance of five points (brightness)}}{\text{Minimum Luminance of five points (brightness)}}$$

10. Handling Precautions

- a) Be sure to turn off the power supply when inserting or disconnecting the cable.
- b) Be sure to design the cabinet so that the module can be installed without any extra stress such as warp or twist.
- c) Since the front polarize is easily damaged, pay attention not to scratch it.
- d) Since long contact with water may cause discoloration or spots, wipe off water drop immediately.
- e) When the panel surface is soiled, wipe it with absorbent cotton or other soft cloth.
- f) Since the panel is made of glass, it may break or crack if dropped or bumped on hard surface. Handle with care.
- g) Since CMOS LSI is used in this module, take care of static electricity and take the human earth into consideration when handling.
- h) Make sure the four mounting holes of the module are grounded sufficiently. Take electro-magnetic interference (EMI) into consideration.
- i) The module has some printed circuit boards (PCBs) on the back side. Take care to keep them from any stress or pressure when handling or installing the module; otherwise some of electronic parts on the PCBs may be damaged.
- j) Observe all other precautionary requirements in handling components.
- k) When some pressure is added onto the module from rear side constantly, it causes display non-uniformity issue, functional defect, etc. So, please avoid such design.
- l) When handling LCD modules and assembling them into cabinets, please be noted that long-term storage in the environment of oxidization or deoxidization gas and the use of such materials as reagent, solvent, adhesive, resin, etc. which generate these gasses, may cause corrosion and discoloration of the LCD modules.

11. Packing form

- a) Production country : JAPAN , TAIWAN, CHINA
- b) Piling number of cartons : maximum 6 cartons
- c) Packing quantity in one carton : 10 modules
- d) Carton size : 408mm(W)× 340mm(H)× 398mm(D)
- e) total mass of one carton filled with full modules : 12.0kg(typ.)
- f) Packing form is shown in Fig.3

12 . Reliability test items

No	Test item	Conditions
1	High temperature storage test	Ta = 60°C 240h
2	Low temperature storage test	Ta = -25°C 240h
3	High temperature & high humidity operation test	Ta = 40°C ; 95%RH 240h (No condensation)
4	High temperature operation test	Ta = 60°C 240h (The temperature of panel surface)
5	Low temperature operation test	Ta = 0°C 240H
6	Vibration test (non- operating)	Waveform : Sine wave Frequency : 10 ~ 57Hz/Vibration width (one side) : 0.075mm : 58 ~ 500Hz/Gravity : 9.8m/s ² Sweep time : 11minutes Test period : 3 hours (1 hour for each direction of X,Y,Z)
7	Shock test (non- operating)	Max. gravity : 490m/s ² Pulse width : 11ms, sine wave Direction : ± X, ± Y, ± Z, once for each direction.
8	Thermal shock test (Storage)	Ta=-25°C ~ 60°C ; 5 cycles Test period : 10 hours (1 hour for each temperature)
9	Altitude	Ta=50°C,70kPa,3,048m(10,000ft), t=24h (Operating) Ta=70°C,12kPa,15,240m(50,000ft), t=24h (Storage)

【Result Evaluation Criteria】

Under the display quality test conditions with normal operation state, these shall be no change which may affect practical display function.

13 . Others

1) Lot No. and indication Bar Code Label:

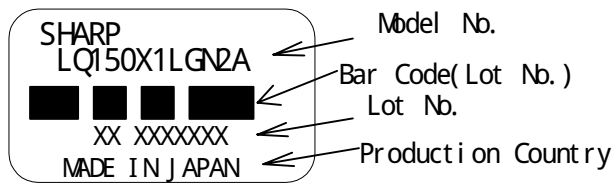

Production country

Japan	MADE IN JAPAN
Taiwan	MADE IN TAIWAN
China	MADE IN CHINA

How to express Lot No.

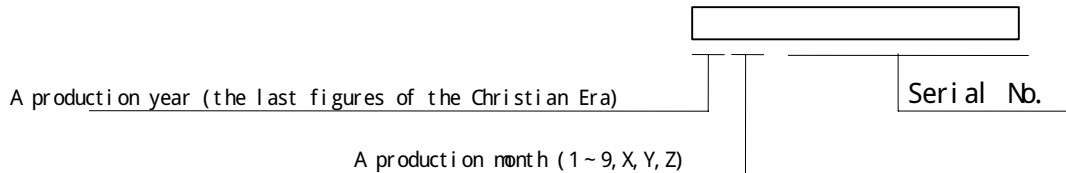

2) Packing Label

社内品番 : (4 S) LQ150X1LGN2A

Bar code (①)

Lot NO. : (1 T) 2 0 0 4 . X . X X

Bar code (②)

Quantity : (Q) 1 0 p c s

Bar code (③)

ユーザ品番 :

シャープ物流用ラベルです。

Made in JAPAN / CHINA

TYPE	L Q 1 5 0 X 1 L G N 2 A	①
QUANTITY	1 0	③
LOT(DATA)	0 4 . 0 9 . 2 4	②

Made in TAIWAN

- ① Model No. (LQ150X1LGN2A)
- ② Lot No. (Date)
- ③ Quantity

- 3) Adjusting volume have been set optimally before shipment, so do not change any adjusted value.
If adjusted value is changed, the specification may not be satisfied.
- 4) Disassembling the module can cause permanent damage and should be strictly avoided.
- 5) Please be careful since image retention may occur when a fixed pattern is displayed for a long time.
- 6) The chemical compound which causes the destruction of ozone layer is not being used.
- 7) Warning of mercury and material information of LPG (Light Pipe Guide) are printed on the back of the module.

MATERIAL INFORMATION
>PLASTIC LIGHT GUIDE:PMMA<

- 8) Cold cathode fluorescent lamp in LCD PANEL contains a small amount of mercury, Please follow local ordinances or regulations for disposal.

COLD CATHODE FLUORESCENT LAMP IN LCD PANEL
 CONTAINS A SMALL AMOUNT OF MERCURY, PLEASE FOLLOW
 LOCAL ORDINANCES OR REGULATION FOR DISPOSAL
 当該液晶ディスプレイパネルは蛍光管が組み込まれていますので、地方自治体の条
 例、または、規則に従って廃棄ください。

- 9) When any question or issue occurs, it shall be solved by mutual discussion.

14. Carton storage condition

Temperature 0°C to 40°C

Humidity 95%RH or less

Reference condition : 20°C to 35°C , 85%RH or less (summer)

: 5°C to 15°C , 85%RH or less (winter)

• the total storage time (40°C,95%RH) : 240H or less

Sunlight Be sure to shelter a product from the direct sunlight.

Atmosphere Harmful gas, such as acid and alkali which bites electronic components and/or wires must not be detected.

Notes Be sure to put cartons on palette or base, don't put it on floor, and store them with removing from wall

Please take care of ventilation in storehouse and around cartons, and control changing temperature is within limits of natural environment

Storage period 1 year

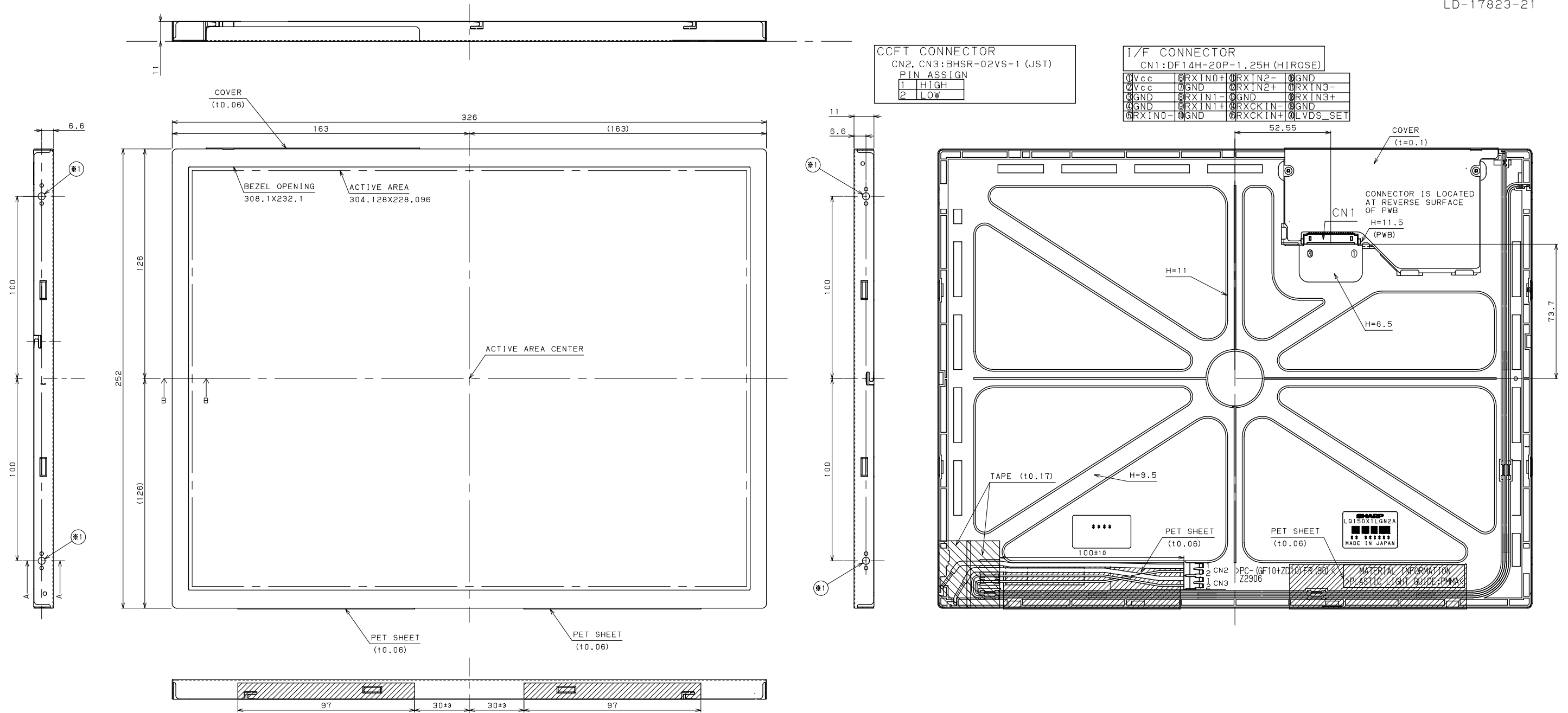

CCFT CONNECTOR
CN2, CN3: BHSR-02VS-1 (JST)
PIN ASSIGN

1	HIGH
2	LOW

I/F CONNECTOR
CN1: DF14H-20P-1, 25H (HIROSE)

① Vcc	② RXIN0+	③ RXIN2-	④ GND
⑤ Vcc	⑥ GND	⑦ RXIN2+	⑧ RXIN3-
⑨ GND	⑩ RXIN1-	⑪ GND	⑫ RXIN3+
⑬ GND	⑭ RXIN1+	⑮ RXCKIN-	⑯ GND
⑰ RXIN0-	⑱ GND	⑳ RXCKIN+	㉑ LVDS_SET

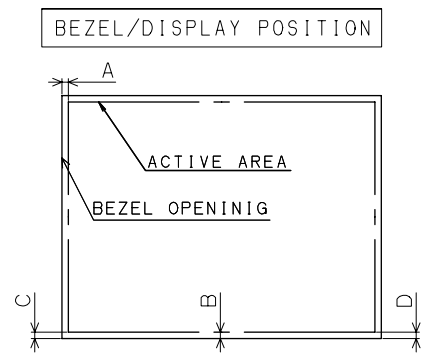
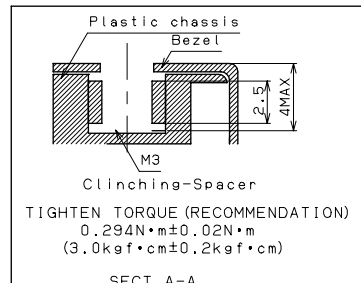
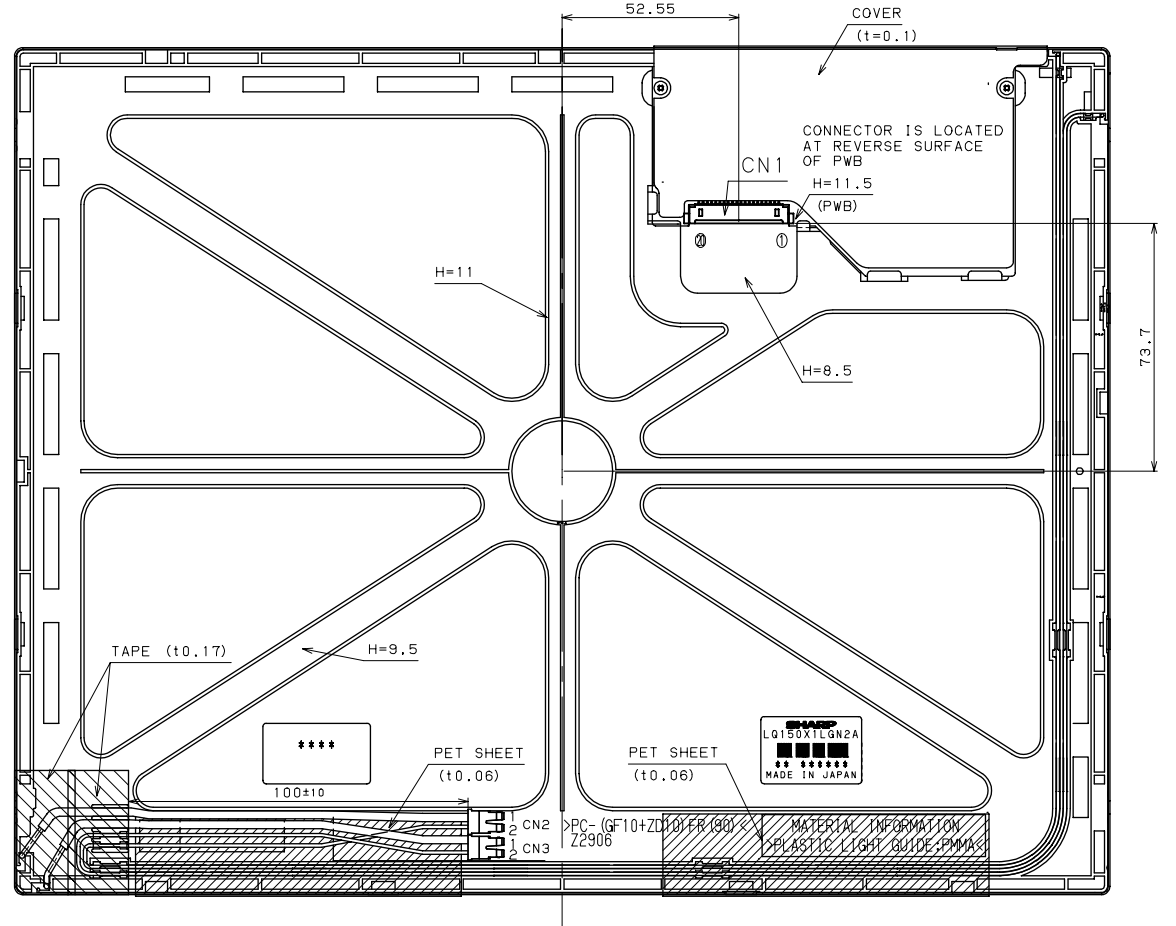

- 1) TOLERANCE X-DIRECTION A: 2.0 ± 0.8
- 2) TOLERANCE Y-DIRECTION B: 2.0 ± 0.8
- 3) OBLIQUITY OF DISPLAY AREA IC-DI < 0.8

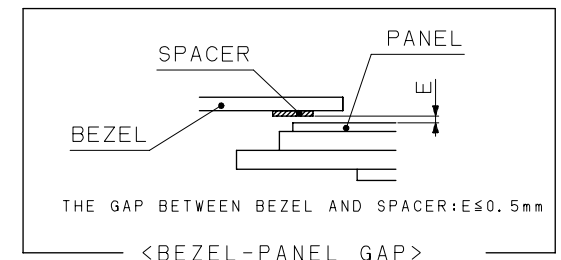
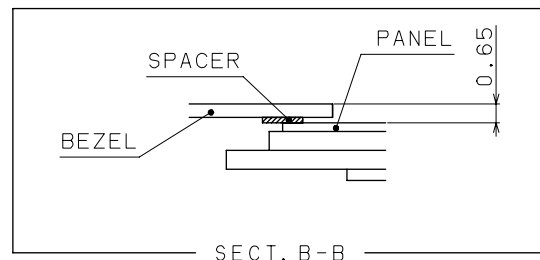
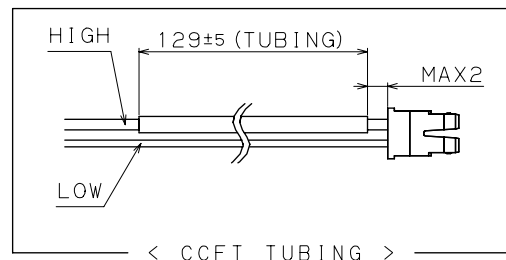

- NOTES)
- 1) UNSPECIFIED TOLERANCE TO BE ± 0.5.
 - 2) WARPING OF COMPONENTS SUCH AS TAPE, BEZEL, PCB, CHASSIS, FPC, PROTECTION COVER, ETC. ARE EXCLUDED FROM THICKNESS AND DIMENSIONS OF THE MODULE.

Fig.1 LQ150X1LGN2A OUTLINE DIMENSIONS

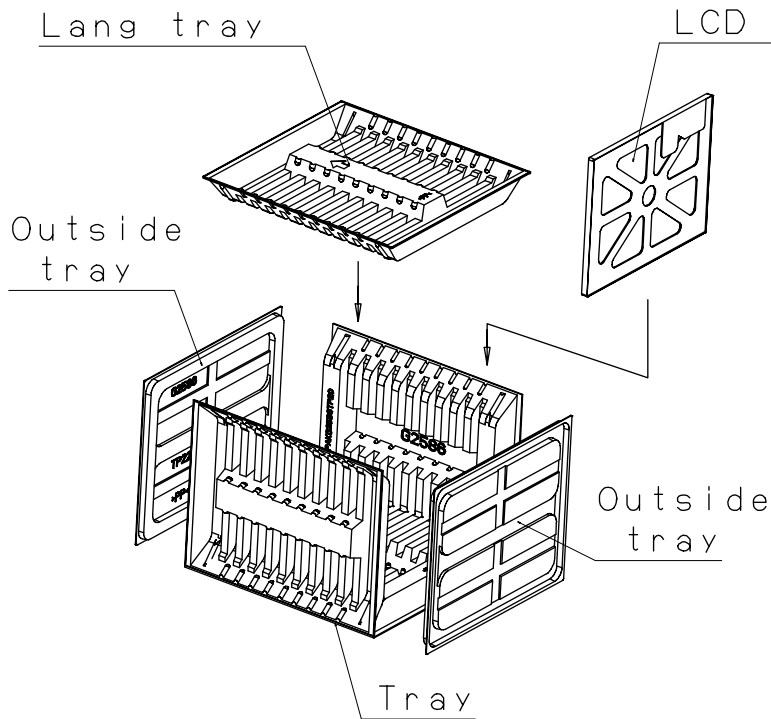

※Made in JAPAN/CHINA

社内品番: (4S) LQ150X1LGN2A	← ①
LotNO. : (1T) 2004. 12. 07	← ②
Quantity: (Q) 10 pcs	← ③
ユーザー品番 :	

シャープ製専用ラベルです。

※Made in TAIWAN

TYPE	LQ150X1LGN2A	← ①
QUANTITY	10	← ③
LOT (DATE)	04. 12. 07	← ②

- ① Model No.
- ② Lot No. (Date)
- ③ Quantity

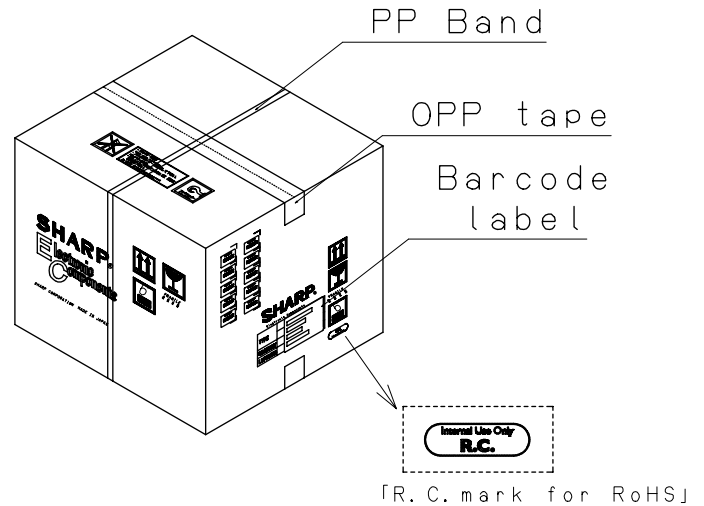
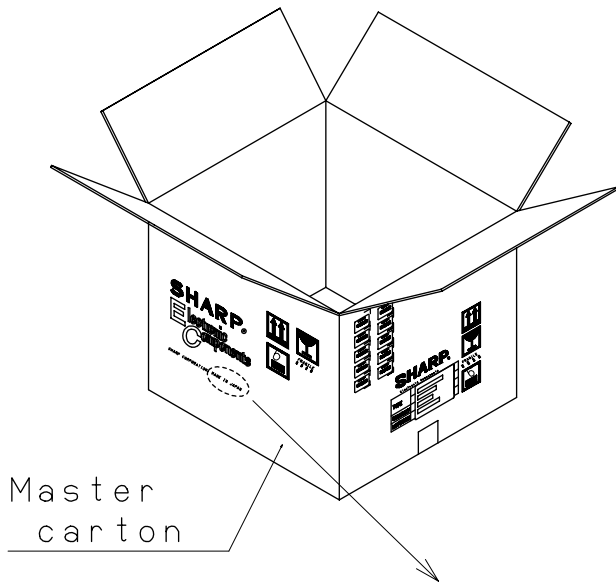

※A production country is JAPAN : "MADE IN JAPAN"
 A production country is CHINA : "MADE IN CHINA"
 A production country is TAIWAN : "MADE IN TAIWAN"

Fig.3 Packing Form (LQ150X1LGN2A)