



Chipsmall Limited consists of a professional team with an average of over 10 year of expertise in the distribution of electronic components. Based in Hongkong, we have already established firm and mutual-benefit business relationships with customers from,Europe,America and south Asia,supplying obsolete and hard-to-find components to meet their specific needs.

With the principle of “Quality Parts,Customers Priority,Honest Operation,and Considerate Service”,our business mainly focus on the distribution of electronic components. Line cards we deal with include Microchip,ALPS,ROHM,Xilinx,Pulse,ON,Everlight and Freescale. Main products comprise IC,Modules,Potentiometer,IC Socket,Relay,Connector.Our parts cover such applications as commercial,industrial, and automotives areas.

We are looking forward to setting up business relationship with you and hope to provide you with the best service and solution. Let us make a better world for our industry!



Contact us

Tel: +86-755-8981 8866 Fax: +86-755-8427 6832

Email & Skype: info@chipsmall.com Web: www.chipsmall.com

Address: A1208, Overseas Decoration Building, #122 Zhenhua RD., Futian, Shenzhen, China



CHIP COIL (CHIP INDUCTORS) LQP03TN□□□□02D REFERENCE SPECIFICATION

1.Scope

This reference specification applies to LQP03TN_02 series, Chip coil (Chip Inductors).

2.Part Numbering

(ex) LQ P 03 T N 0N6 B 0 2 D
 Product ID Structure Dimension Applications Category Inductance Tolerance Features Electrode Packaging
 (L×W) and Characteristics D:Taping
 *B:Bulk

*Bulk packing also available. (A product is put in the plastic bag under the taping conditions.)

3.Rating

- Operating Temperature Range. -55°C to +125°C
 (Ambient temperature: Rated current can be handled in this temperature range.)
- Storage Temperature Range. -55°C to +125°C

Customer Part Number	MURATA Part Number	Inductance		Q (min)	DC Resistance (Ω max)	Self Resonant Frequency (MHz)		Rated Current (mA)
		(nH)	Tolerance			Min.	*Typ.	
	LQP03TN0N6B02D	0.6	B:±0.1nH C:±0.2nH	14	0.07	20000	20000	850
	LQP03TN0N6C02D							
	LQP03TN0N7B02D	0.7			0.08	18000		800
	LQP03TN0N7C02D							
	LQP03TN0N8B02D	0.8			0.10	17000		750
	LQP03TN0N8C02D							
	LQP03TN0N9B02D	0.9			0.15	15000		600
	LQP03TN0N9C02D							
	LQP03TN1N0B02D	1.0			16000	19600		600
	LQP03TN1N0C02D							
	LQP03TN1N1B02D	1.1			17900	20000		600
	LQP03TN1N1C02D							
	LQP03TN1N2B02D	1.2			19100	17700		600
	LQP03TN1N2C02D							
	LQP03TN1N3B02D	1.3			15100	14800		500
	LQP03TN1N3C02D							
	LQP03TN1N4B02D	1.4			13900	13400		500
	LQP03TN1N4C02D							
	LQP03TN1N5B02D	1.5			11000	12900		500
	LQP03TN1N5C02D							
	LQP03TN1N6B02D	1.6			12200	12900		500
	LQP03TN1N6C02D							
	LQP03TN1N7B02D	1.7			10000	12200		500
	LQP03TN1N7C02D							
	LQP03TN1N8B02D	1.8	10000	12200	500			
	LQP03TN1N8C02D							
	LQP03TN1N9B02D	1.9	10000	12200	500			
	LQP03TN1N9C02D							
	LQP03TN2N0B02D	2.0	10000	12200	500			
	LQP03TN2N0C02D							
	LQP03TN2N1B02D	2.1	10000	12200	500			
	LQP03TN2N1C02D							
	LQP03TN2N2B02D	2.2	10000	12200	500			
	LQP03TN2N2C02D							
	LQP03TN2N3B02D	2.3	10000	12200	500			
	LQP03TN2N3C02D							
	LQP03TN2N4B02D	2.4	10000	12200	500			
	LQP03TN2N4C02D							

Customer Part Number	MURATA Part Number	Inductance		Q (min)	DC Resistance (Ω max)	Self Resonant Frequency (MHz)		Rated Current (mA)
		(nH)	Tolerance			Min.	*Typ.	
	LQP03TN2N5B02D	2.5	B:±0.1nH C:±0.2nH	14	0.20	10000	12200	500
	LQP03TN2N5C02D						2.6	
	LQP03TN2N6B02D	2.7						
	LQP03TN2N6C02D					2.8	11800	
	LQP03TN2N7B02D	2.9					9500	
	LQP03TN2N7C02D					3.0	11900	
	LQP03TN2N8B02D	3.1			0.25		8000	11300
	LQP03TN2N8C02D					3.2		10600
	LQP03TN2N9B02D	3.3						10900
	LQP03TN2N9C02D					3.4	7000	9400
	LQP03TN2N0B02D	3.5					7000	9600
	LQP03TN2N0C02D					3.6		0.30
	LQP03TN2N1B02D	3.7	8200					
	LQP03TN2N1C02D		3.8	8100				
	LQP03TN2N2B02D	3.9		5700	7900			
	LQP03TN2N2C02D		4.0	0.40	5300	8600	350	
	LQP03TN2N3B02D	4.1				8400		
	LQP03TN2N3C02D		4.2			8600		
	LQP03TN2N4B02D	4.3			9800			
	LQP03TN2N4C02D		4.7		4400	8800		
	LQP03TN2N5B02D	5.1			4200	8600		
	LQP03TN2N5C02D		5.6	4000	8000			
	LQP03TN2N6B02D	6.2			0.60	7900	300	
	LQP03TN2N6C02D		6.8	3900		8000		
	LQP03TN2N7B02D	7.5		3700		6700		
	LQP03TN2N7C02D		8.2	3600		6600		
	LQP03TN2N8B02D	9.1				0.70		3300
	LQP03TN2N8C02D			5900				

Customer Part Number	MURATA Part Number	Inductance		Q (min)	DC Resistance (Ω max)	Self Resonant Frequency (MHz)		Rated Current (mA)
		(nH)	Tolerance			Min.	*Typ.	
	LQP03TN10NH02D	10	H:±3% J:±5%	14	0.70	3200	5800	250
	LQP03TN10NJ02D							
	LQP03TN11NH02D	11			0.80	2900	5400	
	LQP03TN11NJ02D							
	LQP03TN12NH02D	12		0.70	2600	4300		
	LQP03TN12NJ02D							
	LQP03TN13NH02D	13		0.80	2600	3800		
	LQP03TN13NJ02D							
	LQP03TN15NH02D	15		0.70	2200	3700		
	LQP03TN15NJ02D							
	LQP03TN16NH02D	16		0.95	2200	3400		
	LQP03TN16NJ02D							
	LQP03TN18NH02D	18		0.80	2200	3600		
	LQP03TN18NJ02D							
	LQP03TN20NH02D	20		2.30	2000	3300		
	LQP03TN20NJ02D							
	LQP03TN22NH02D	22		1.90	2000	3200		
	LQP03TN22NJ02D							
	LQP03TN24NH02D	24		2.30	2000	2900		
	LQP03TN24NJ02D							
	LQP03TN27NH02D	27	2.95	1700	2700			
	LQP03TN27NJ02D							
	LQP03TN30NH02D	30	2.95	1700	2600			
	LQP03TN30NJ02D							
	LQP03TN33NH02D	33	3.00	1500	2400			
	LQP03TN33NJ02D							
	LQP03TN36NH02D	36	3.00	1500	2200			
	LQP03TN36NJ02D							
	LQP03TN39NH02D	39	3.60	1300	2000			
	LQP03TN39NJ02D							
	LQP03TN43NH02D	43	3.60	1300	2000			
	LQP03TN43NJ02D							
	LQP03TN47NH02D	47	3.90	1200	1800			
	LQP03TN47NJ02D							
	LQP03TN51NH02D	51	3.90	1200	1500			
	LQP03TN51NJ02D							
	LQP03TN56NH02D	56	8	1100	1400			
	LQP03TN56NJ02D							
	LQP03TN62NH02D	62	8	1100	1400			
	LQP03TN62NJ02D							
	LQP03TN68NH02D	68	10	1000	1300			
	LQP03TN68NJ02D							
	LQP03TN75NH02D	75	10	1000	1400			
	LQP03TN75NJ02D							
	LQP03TN82NH02D	82	12	800	1100			
	LQP03TN82NJ02D							
	LQP03TN91NH02D	91	12	800	1100			
	LQP03TN91NJ02D							
	LQP03TNR10H02D	100	12	800	1100			
	LQP03TNR10J02D							
	LQP03TNR11H02D	110	12	800	1100			
	LQP03TNR11J02D							
	LQP03TNR12H02D	120	12	800	1100			
	LQP03TNR12J02D							

Customer Part Number	MURATA Part Number	Inductance		Q (min)	DC Resistance (Ω max)	Self Resonant Frequency (MHz)		Rated Current (mA)		
		(nH)	Tolerance			Min.	*Typ.			
	LQP03TNR13H02D	130	H: \pm 3% J: \pm 5%	5	9	650	960	80		
	LQP03TNR13J02D						880			
	LQP03TNR15H02D	150				600	11		840	790
	LQP03TNR15J02D									
	LQP03TNR16H02D	160			500	13	750	710		
	LQP03TNR16J02D									
	LQP03TNR18H02D	180			450	15	630	580		
	LQP03TNR18J02D									
	LQP03TNR20H02D	200			750	60	710	630		
	LQP03TNR20J02D									
	LQP03TNR22H02D	220	710	60	630	580				
	LQP03TNR22J02D									
	LQP03TNR24H02D	240	580	60	630	580				
	LQP03TNR24J02D									
	LQP03TNR27H02D	270	580	60	630	580				
	LQP03TNR27J02D									

* Typical value is actual performance.

4. Testing Conditions

《Unless otherwise specified》

Temperature : Ordinary Temperature / 15°C to 35°C
 Humidity : Ordinary Humidity / 25%(RH) to 85 %(RH)

《In case of doubt》

Temperature : 20°C \pm 2°C
 Humidity : 60%(RH) to 70 %(RH)
 Atmospheric Pressure : 86kPa to 106 kPa

5. Appearance and Dimensions

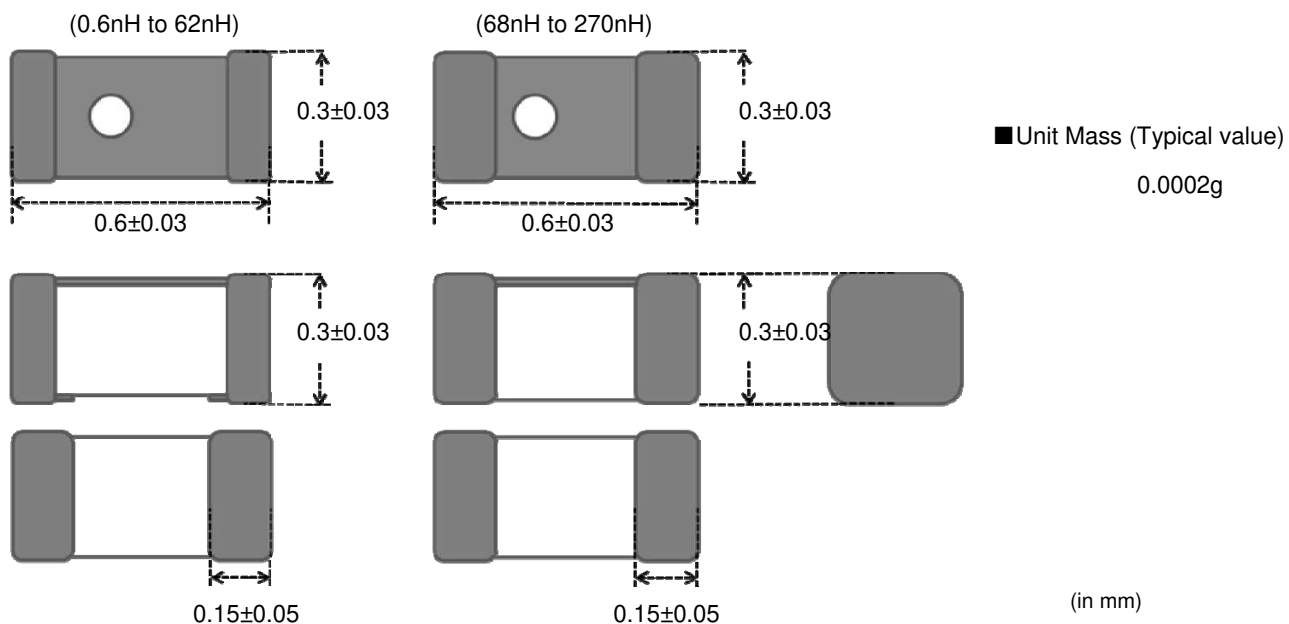

6. Marking

Polarity Marking :white

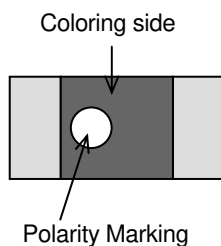
**7. Electrical Performance**

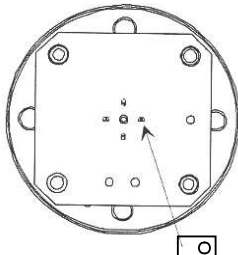
No.	Item	Specification	Test Method
7.1	Inductance	Inductance shall meet item 3.	Measuring Equipment: KEYSIGHT E4991A or equivalent Measuring Frequency: (0.6nH~30nH) 500MHz (33nH~120nH) 300MHz (130nH~270nH) 100MHz Measuring Condition: Test signal level / about 0dBm Electrical length / 10mm Weight / about 1N to 5N Measuring Fixture: KEYSIGHT 16197A Position coil under test as shown in below and contact coil with each terminal by adding weight. Coloring side should be a topside, and should be in the direction of the fixture for position of chip coil.
7.2	Q	Q shall meet item 3.	 <p style="text-align: center;">↑ Polarity Marking</p> Measuring Method: See P.12 <Electrical Performance: Measuring Method of Inductance/Q>
7.3	DC Resistance	DC Resistance shall meet item 3.	Measuring Equipment: Digital multi meter
7.4	Self Resonant Frequency(S.R.F)	S.R.F shall meet item 3.	Measuring Equipment: KEYSIGHT N5230A or equivalent
7.5	Rated Current	Self temperature rise shall be limited to 25°C max.	The rated current is applied.

8. Mechanical Performance

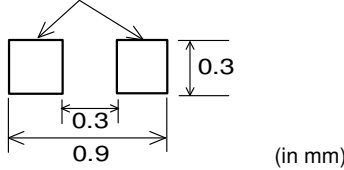
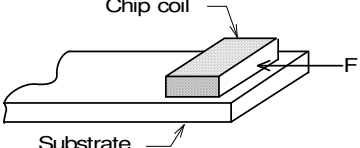
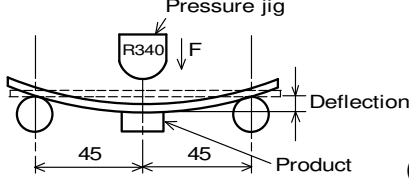
No.	Item	Specification	Test Method
8.1	Shear Test	Chip coil shall not be damaged after tested as test method.	Substrate: Glass-epoxy substrate Land  Force: 2N Hold Duration: 5 s ± 1 s Applied Direction: Parallel to PCB. 
8.2	Bending Test	Chip coil shall not be damaged after tested as test method.	Substrate: Glass-epoxy substrate (100mm × 40mm × 0.8mm) Speed of Applying Force: 1mm / s Deflection: 1mm Hold Duration: 30 s 
8.3	Vibration	Appearance: No damage Inductance Change: within ±10%	Substrate: Glass-epoxy substrate Oscillation Frequency: 10Hz to 2000Hz to 10Hz for 20 min Total amplitude 1.5 mm or Acceleration amplitude 196 m/s ² whichever is smaller. Testing Time: A period of 2h in each of 3 mutually perpendicular directions.
8.4	Solderability	The electrode shall be at least 90% covered with new solder coating.	Flux: Ethanol solution of rosin 25(wt)% (Immersed for 5s to 10s) Solder: Sn-3.0Ag-0.5Cu Pre-Heating: 150°C ± 10°C / 60s to 90s Solder Temperature: 240°C ± 5°C Immersion Time: 3s ± 1s
8.5	Resistance to Soldering Heat	Appearance: No damage Inductance Change: within ±10%	Flux: Ethanol solution of rosin 25(wt)% (Immersed for 5s to 10s) Solder: Sn-3.0Ag-0.5Cu Pre-Heating: 150°C ± 10°C / 60s to 90s Solder Temperature: 260°C ± 5°C Immersion Time: 5s ± 1s Then measured after exposure in the room condition for 24h ± 2h.

9.Environmental Performance

It shall be soldered on the substrate.

No.	Item	Specification	Test Method
9.1	Heat Resistance	Appearance:No damage Inductance Change: within $\pm 10\%$	Substrate:Glass-epoxy substrate Temperature:125°C Time:1000h (+48h,-0h) Then measured after exposure in the room condition for 24h \pm 2h.
9.2	Cold Resistance		Substrate:Glass-epoxy substrate Temperature:-55°C Time:1000 h (+48h,-0h) Then measured after exposure in the room condition for 24h \pm 2h.
9.3	Humidity		Substrate:Glass-epoxy substrate Temperature:40°C \pm 2°C Humidity:90%(RH) to 95%(RH) Time:1000 h(+48h,-0h) Then measured after exposure in the room condition for 24h \pm 2h.
9.4	Temperature Cycle		Substrate:Glass-epoxy substrate 1 cycle: 1 step: -55°C / 30min \pm 3 min 2 step: Ordinary temp. / 10~15 min 3 step: 125°C / 30min \pm 3 min 4 step: Ordinary temp. / 10~15 min Total of 10 cycles Then measured after exposure in the room condition for 24h \pm 2h.

10.Specification of Packaging

10.1 Appearance and Dimensions of paper tape (8mm-wide)

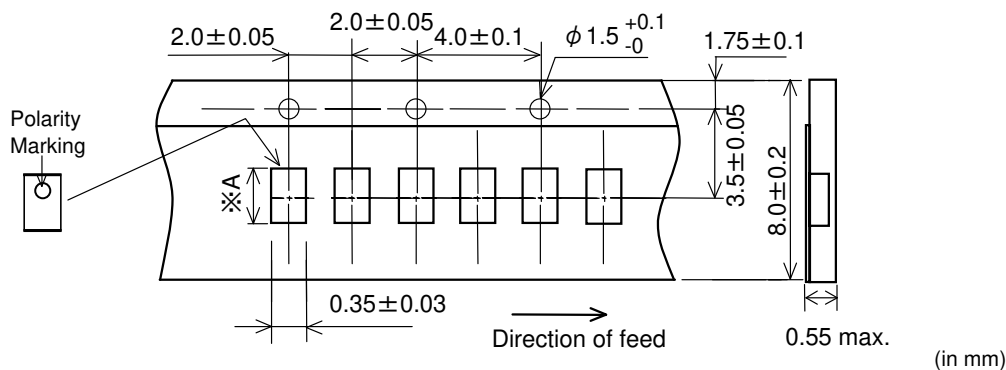

※A 0N6~62N、R13~R27 ; 0.67 \pm 0.03
68N~R12 ; 0.65 \pm 0.03

10.2 Specification of Taping

- (1) Packing quantity (standard quantity)
15,000 pcs. / reel
- (2) Packing Method
Products shall be packed in the cavity of the base tape and sealed by cover tape.
- (3) Sprocket hole
The sprocket holes are to the right as the tape is pulled toward the user.
- (4) Spliced point
Base tape and Cover tape has no spliced point.
- (5) Missing components number
Missing components number within 0.1 % of the number per reel or 1 pc. , whichever is greater, and are not continuous. The Specified quantity per reel is kept.

10.3 Pull Strength

Cover tape	5N min
------------	--------

10.4 Peeling off force of cover tape

Speed of Peeling off	300mm/min
Peeling off force	0.1N to 0.6N (minimum value is typical)

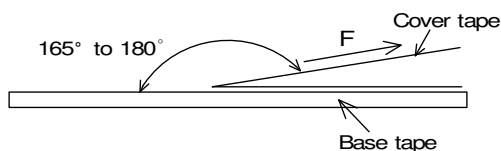

10.5 Dimensions of Leader-tape, Trailer and Reel

There shall be leader-tape (top tape and empty tape) and trailer-tape (empty tape) as follows.

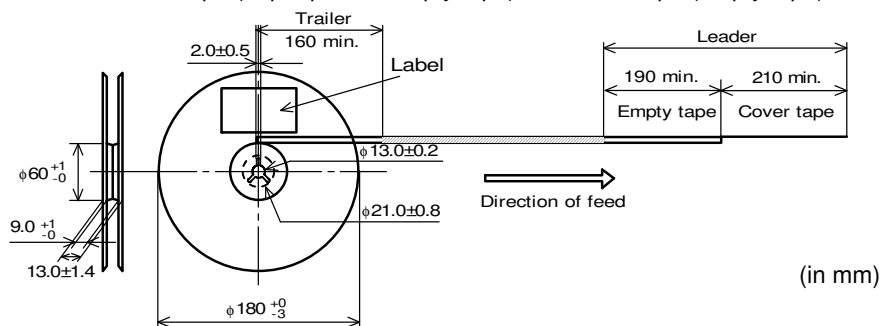

10.6 Marking for reel

Customer part number, MURATA part number, Inspection number(*1) , RoHS Marking (*2), Quantity etc ...

*1) <Expression of Inspection No.>

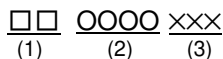

(1) Factory Code

(2) Date

First digit : Year / Last digit of year

Second digit : Month / Jan. to Sep. → 1 to 9, Oct. to Dec. → O,N,D

Third, Fourth digit : Day

(3) Serial No.

*2) <Expression of RoHS Marking>

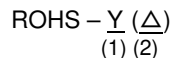

(1) RoHS regulation conformity parts.

(2) MURATA classification number

10.7 Marking for Outside package (corrugated paper box)

Customer name, Purchasing order number, Customer part number, MURATA part number, RoHS Marking (*2) ,Quantity, etc ...

10.8 Specification of Outer Case

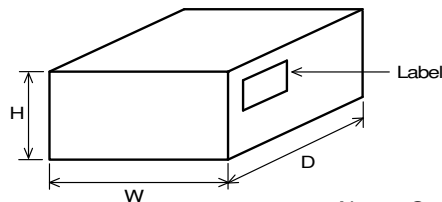

Outer Case Dimensions (mm)			Standard Reel Quantity in Outer Case (Reel)
W	D	H	
186	186	93	5

* Above Outer Case size is typical. It depends on a quantity of an order.

11. ⚠ Caution

Limitation of Applications

Please contact us before using our products for the applications listed below which require especially high reliability for the prevention of defects which might directly cause damage to the third party's life, body or property.

- (1) Aircraft equipment
- (2) Aerospace equipment
- (3) Undersea equipment
- (4) Power plant control equipment
- (5) Medical equipment
- (6) Transportation equipment (vehicles, trains, ships, etc.)
- (7) Traffic signal equipment
- (8) Disaster prevention / crime prevention equipment
- (9) Data-processing equipment
- (10) Applications of similar complexity and /or reliability requirements to the applications listed in the above

12. Notice

Products can only be soldered with reflow.

This product is designed for solder mounting.

Please consult us in advance for applying other mounting method such as conductive adhesive.

12.1 Land pattern designing

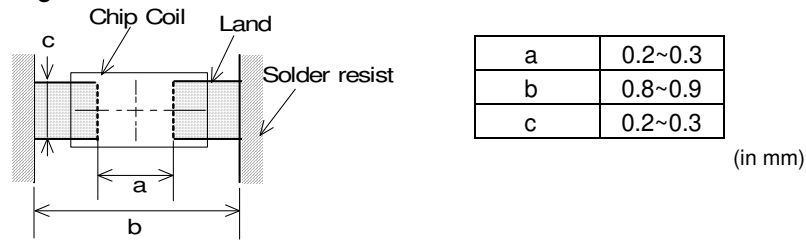

12.2 Flux, Solder

- Use rosin-based flux.
Don't use highly acidic flux with halide content exceeding 0.2(wt)% (chlorine conversion value).
Don't use water-soluble flux.
- Use Sn-3.0Ag-0.5Cu solder.
- Standard thickness of solder paste : 100 μm~150 μm.

12.3 Reflow soldering conditions

- Pre-heating should be in such a way that the temperature difference between solder and product surface is limited to 150°C max. Cooling into solvent after soldering also should be in such a way that the temperature difference is limited to 100°C max.
Insufficient pre-heating may cause cracks on the product, resulting in the deterioration of products quality.
- Standard soldering profile and the limit soldering profile is as follows.
The excessive limit soldering conditions may cause leaching of the electrode and / or resulting in the deterioration of product quality.
- Reflow soldering profile

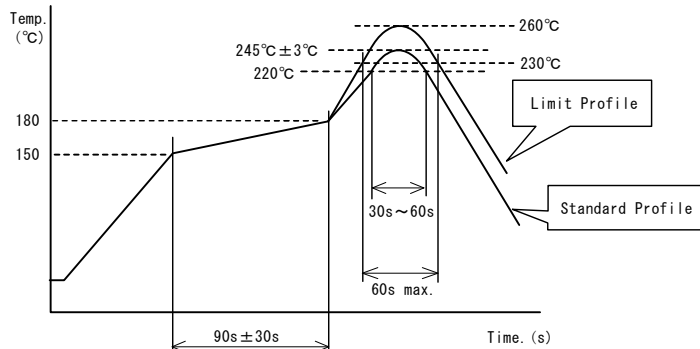

	Standard Profile	Limit Profile
Pre-heating	150°C~180°C , 90s±30s	
Heating	above 220°C, 30s~60s	above 230°C, 60s max.
Peak temperature	245°C±3°C	260°C, 10s
Cycle of reflow	2 times	

12.4 Reworking with soldering iron

The following conditions must be strictly followed when using a soldering iron.

Pre-heating	150°C,1 min
Tip temperature	350°C max.
Soldering iron output	80W max.
Tip diameter	φ 3mm max.
Soldering time	3(+1,-0)s
Time	2 times

Note : Do not directly touch the products with the tip of the soldering iron in order to prevent the crack on the products due to the thermal shock.

12.5 Solder Volume

- Solder shall be used not to be exceeded the upper limits as shown below.

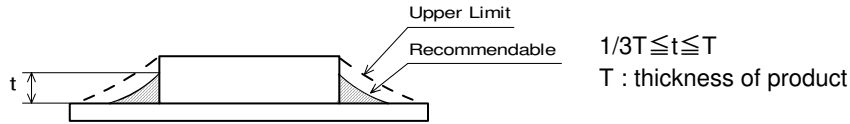

Accordingly increasing the solder volume, the mechanical stress to Chip is also increased. Exceeding solder volume may cause the failure of mechanical or electrical performance.

12.6 Attention regarding P.C.B. bending

The following shall be considered when designing and laying out P.C.B.'s.

- (1) P.C.B. shall be designed so that products are not subject to the mechanical stress due to warping the board.

[Products direction]

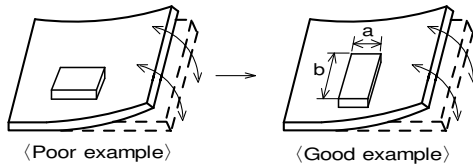

Products shall be located in the sideways direction (Length:a<b) to the mechanical stress.

- (2) Products location on P.C.B. separation

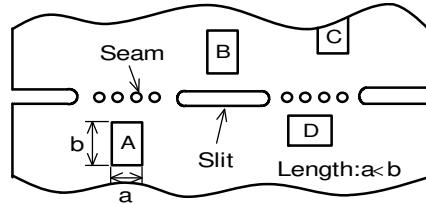

Products (A,B,C,D) shall be located carefully so that products are not subject to the mechanical stress due to warping the board. Because they may be subjected the mechanical stress in order of $A > C > B \cong D$.

12.7 Cleaning Conditions

Products shall be cleaned on the following conditions.

- (1) Cleaning temperature shall be limited to 60°C max.(40°C max for IPA)
- (2) Ultrasonic cleaning shall comply with the following conditions with avoiding the resonance phenomenon at the mounted products and P.C.B.
Power : 20 W / l max. Frequency : 28kHz to 40kHz Time : 5 min max.
- (3) Cleaner
 1. Alcohol type cleaner
Isopropyl alcohol (IPA)
 2. Aqueous agent
PINE ALPHA ST-100S
- (4) There shall be no residual flux and residual cleaner after cleaning.
In the case of using aqueous agent, products shall be dried completely after rinse with de-ionized water in order to remove the cleaner.
- (5) Other cleaning Please contact us.

12.8 Resin coating

When products are coated with resin, please contact us in advance.

12.9 Handling of a substrate

(1) There is a possibility of chip cracking caused by PCB expansion/contraction with heat, because stress on a chip is different depending on PCB material and structure.

When the thermal expansion coefficient greatly differs between the board used for mounting and the chip, it will cause cracking of the chip due to the thermal expansion and contraction.

The chip is assumed to be mounted on the PCB of glass-epoxy material, and we don't test with other PCB material which has different thermal expansion coefficient from Glass-epoxy.

When other PCB materials are considered, please be sure to evaluate by yourself.

(2) After mounting products on a substrate, do not apply any stress to the product caused by bending or twisting to the substrate when cropping the substrate, inserting and removing a connector from the substrate or tightening screw to the substrate.

Excessive mechanical stress may cause cracking in the product.

In case of the mounting on flexible PCB, there is a possibility of chip cracking caused by mechanical stress even from small bending or twisting.

When the flexible PCB is considered, please be sure to evaluate by yourself.

Bending

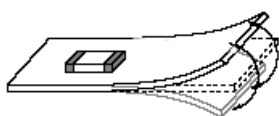

Twisting

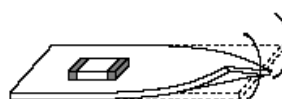
**12.10 Storage and Handling Requirements**

(1) Storage period

Use the products within 12 months after delivered.

Solderability should be checked if this period is exceeded.

(2) Storage conditions

• Products should be stored in the warehouse on the following conditions.

Temperature : -10°C ~ 40°C

Humidity : 15% to 85% relative humidity No rapid change on temperature and humidity.

• Products should not be stored on bulk packaging condition to prevent the chipping of the core and the breaking of winding wire caused by the collision between the products.

• Products should be stored on the palette for the prevention of the influence from humidity, dust and so on.

• Products should be stored in the warehouse without heat shock, vibration, direct sunlight and so on.

(3) Handling Condition

Care should be taken when transporting or handling product to avoid excessive vibration or mechanical shock.

13. ⚠ Note

(1) Please make sure that your product has been evaluated in view of your specifications with our product being mounted to your product.

(2) You are requested not to use our product deviating from the reference specifications.

(3) The contents of this reference specification are subject to change without advance notice.

Please approve our product specifications or transact the approval sheet for product specifications before ordering.

<Electrical Performance:Measuring Method of Inductance/Q>

(1) Residual elements and stray elements of test fixture can be described by F-parameter shown in following.

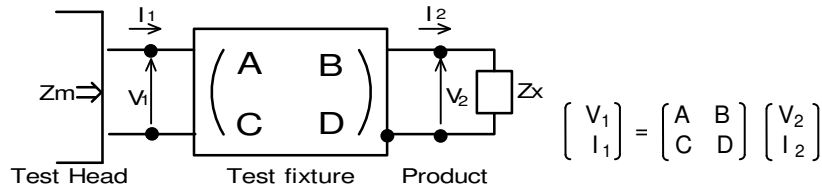

(2) The impedance of chip coil Z_x and measured value Z_m can be described by input/output current/voltage.

$$Z_m = \frac{V_1}{I_1} \quad , \quad Z_x = \frac{V_2}{I_2}$$

(3) Thus,the relation between Z_x and Z_m is following;

$$Z_x = \alpha \frac{Z_m - \beta}{1 - Z_m \Gamma} \quad \text{where, } \alpha = D / A = 1$$

$$\beta = B / D = Z_{sm} - (1 - Y_{om}) Z_{ss}$$

$$\Gamma = C / A = Y_{om}$$

Z_{sm} :measured impedance of short chip
 Z_{ss} :residual impedance of short chip (0.480nH)
 Y_{om} :measured admittance when opening the fixture

(4) L_x and Q_x shall be calculated with the following equation.

$$L_x = \frac{\text{Im}(Z_x)}{2\pi f} \quad , \quad Q_x = \frac{\text{Im}(Z_x)}{\text{Re}(Z_x)}$$

L_x :Inductance of chip coil
 Q_x :Q of chip coil
 f :Measuring frequency