



Chipsmall Limited consists of a professional team with an average of over 10 year of expertise in the distribution of electronic components. Based in Hongkong, we have already established firm and mutual-benefit business relationships with customers from,Europe,America and south Asia,supplying obsolete and hard-to-find components to meet their specific needs.

With the principle of “Quality Parts,Customers Priority,Honest Operation,and Considerate Service”,our business mainly focus on the distribution of electronic components. Line cards we deal with include Microchip,ALPS,ROHM,Xilinx,Pulse,ON,Everlight and Freescale. Main products comprise IC,Modules,Potentiometer,IC Socket,Relay,Connector.Our parts cover such applications as commercial,industrial, and automotives areas.

We are looking forward to setting up business relationship with you and hope to provide you with the best service and solution. Let us make a better world for our industry!



Contact us

Tel: +86-755-8981 8866 Fax: +86-755-8427 6832

Email & Skype: info@chipsmall.com Web: www.chipsmall.com

Address: A1208, Overseas Decoration Building, #122 Zhenhua RD., Futian, Shenzhen, China



LRG-Series

ILLUMINATED DOUBLE POLE ROCKER & PADDLE SWITCHES

The double pole lighted version of the R-Series incorporates the same sleek lines as the original Corvette, in a double pole envelope. This illuminated version features silver-plated butt-action contacts with ratings to 20A/125, 15A 250VAC and withstand peak inrush currents up to 100 amps. Clear or translucent style rocker actuators and a choice of solder lug, .250 Tab and wire lead terminations enable this switch to adapt to high current applications.



Product Highlights:

- ◆ Ratings to 20A
- ◆ Neon or Incandescent Illumination
- ◆ Silver Plated Butt-contact mechanism
- ◆ Clear or translucent style rockers

Typical Applications:

- ◆ Power Supply
- ◆ Appliance
- ◆ Exercise Equipment
- ◆ Music Equipment



Carling Technologies®

Innovative Designs. Powerful Solutions.

Carling Technologies, Inc.
60 Johnson Avenue, Plainville, CT 06062
Email: sales@carlingtech.com
Application Support: team2@carlingtech.com
Phone: 860.793.9281 Fax: 860.793.9231

www.carlingtech.com

Dielectric Strength

UL/CSA:
1000V - live to dead metal parts &
opposite polarity

Electrical Life

50,000 cycles

Mechanical Life

100,000 cycles

Operating Temperature

-40°F to 185°F (-40°C to 85°C)

LRGSCK611 - R S - B - B / 250N

1 Base Part Number

2 Actuator Style

3 Actuator Color

4 Bezel Color

5 Rocker Legend

6 Lamp Voltage

1 BASE PART NUMBER: SERIES / CIRCUITRY / RATING ¹ / TERMINATION

15A 250 VAC, 20A 125 VAC, 3/4 HP 125-250 VAC

	Solder Lugs	.250 Tabs	Wire Leads
Standard Base			
OFF-NONE-ON	LRGSCK610	LRGSCK611	LRGSCK615
European Base (22 x 30 mm cutout)			
OFF-NONE-ON (Single Pole)	LRGSEK610	LRGSEK611	LRGSEK615
15A 6-24 V ³			
Standard Base			
OFF-NONE-ON	LRGSCK510	LRGSCK511	LRGSCK515
European Base (22 x 30 mm cutout)			
OFF-NONE-ON (Single Pole)	LRGSEK510	LRGSEK511	LRGSEK515

4 BEZEL COLOR ¹

B Black	W White
----------------	----------------

5 ROCKER LEGEND

	hot stamp
NO LEGEND	0
OFF-ON vertical	A
OFF-ON horizontal	B
O-I horizontal	D
O-I vertical	E
Dual OFF-ON, O-I vertical	H
Dual OFF-ON, O-I horizontal	J

2 ACTUATOR STYLE

R Rocker (translucent)	C Rocker (clear)
-------------------------------	-------------------------

3 ACTUATOR COLOR

A Amber	L ³ Lime Green
B ^{3,5} Blue	P Yellow
C ⁴ White/Clear	R Red (clear)
G ⁵ Green	S Red
	W Pale Red

6 LAMP VOLTAGE ²

006V 6V incandescent	024V 24V incandescent
012V 12V incandescent	125N 125V neon
018V 18V incandescent	250N 250V neon

Notes:

- Additional ratings, colors and clear style actuators are available. Consult factory.
- Incandescent lamps must specify 15A 24V rating only.
- Available with incandescent lamps only.
- Clear color provided where specified with clear style rocker.
- Available with clear style rocker only.

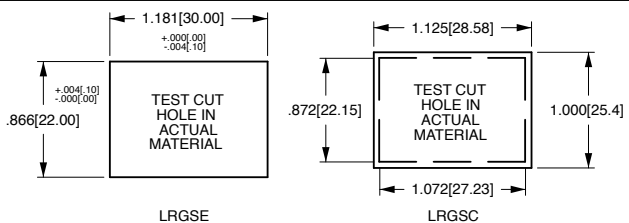
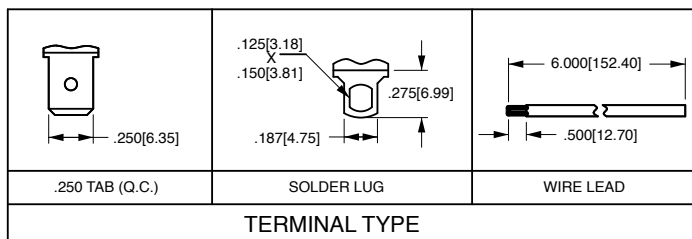
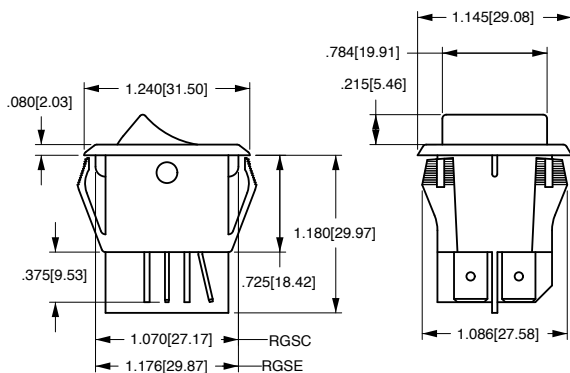

MOUNTING HOLE
Panel Thickness: .025 min - .187 max.
Specific cutout dimension range dependent on panel thickness and material.

*Manufacturer reserves the right to change product specification without prior notice.

Authorized Sales Representatives and Distributors

Click on a region of the map below to find your local representatives and distributors or visit www.carlingtech.com/findarep.



About Carling

Founded in 1920, Carling Technologies is a leading manufacturer of electrical and electronic switches and assemblies, circuit breakers, electronic controls, power distribution units, and multiplexed power distribution systems. With four ISO registered manufacturing facilities and technical sales offices worldwide, Carling Technologies Sales, Service and Engineering teams do much more than manufacture electrical components, they engineer powerful solutions! To learn more about Carling please visit www.carlingtech.com/company-profile.

To view all of Carling's environmental, quality, health & safety certifications please visit www.carlingtech.com/environmental-certifications

Worldwide Headquarters

Carling Technologies, Inc.
60 Johnson Avenue, Plainville, CT 06062
Phone: 860.793.9281 **Fax:** 860.793.9231
Email: sales@carlingtech.com

Northern Region Sales Office: nrsm@carlingtech.com
Southeast Region Sales Office: sersm@carlingtech.com
Midwest Region Sales Office: mrsrm@carlingtech.com
West Region Sales Office: wrsm@carlingtech.com
Latin America Sales Office: larsm@carlingtech.com

Asia-Pacific Headquarters

Carling Technologies, Asia-Pacific Ltd.,
Suite 1607, 16/F Tower 2, The Gateway,
Harbour City, 25 Canton Road,
Tsimshatsui, Kowloon, Hong Kong
Phone: Int + 852-2737-2277 **Fax:** Int + 852-2736-9332
Email: sales@carlingtech.com.hk

Shenzhen, China: shenzhen@carlingtech.com
Shanghai, China: shanghai@carlingtech.com
Pune, India: india@carlingtech.com
Kaohsiung, Taiwan: taiwan@carlingtech.com
Yokohama, Japan: japan@carlingtech.com

Europe | Middle East | Africa Headquarters

Carling Technologies LTD
4 Airport Business Park, Exeter Airport,
Clyst Honiton, Exeter, Devon, EX5 2UL, UK
Phone: Int + 44 1392.364422 **Fax:** Int + 44 1392.364477
Email: ltd.sales@carlingtech.com

Germany: gmbh@carlingtech.com
France: sas@carlingtech.com



Carling Technologies®

Innovative Designs. Powerful Solutions.