



Chipsmall Limited consists of a professional team with an average of over 10 year of expertise in the distribution of electronic components. Based in Hongkong, we have already established firm and mutual-benefit business relationships with customers from,Europe,America and south Asia,supplying obsolete and hard-to-find components to meet their specific needs.

With the principle of “Quality Parts,Customers Priority,Honest Operation,and Considerate Service”,our business mainly focus on the distribution of electronic components. Line cards we deal with include Microchip,ALPS,ROHM,Xilinx,Pulse,ON,Everlight and Freescale. Main products comprise IC,Modules,Potentiometer,IC Socket,Relay,Connector.Our parts cover such applications as commercial,industrial, and automotives areas.

We are looking forward to setting up business relationship with you and hope to provide you with the best service and solution. Let us make a better world for our industry!



Contact us

Tel: +86-755-8981 8866 Fax: +86-755-8427 6832

Email & Skype: info@chipsmall.com Web: www.chipsmall.com

Address: A1208, Overseas Decoration Building, #122 Zhenhua RD., Futian, Shenzhen, China



Multi TOPLED®

LSG T670, LSP T670, LSY T670, LOP T670, LYG T670

**Non-RoHS compliant version of product will be discontinued acc. to OS-PD-2005-005.
The product itself will remain within RoHS compliant version.**



Besondere Merkmale

- **Gehäusotyp:** weißes P-LCC-4 Gehäuse, farbloser klarer Verguss
- **Besonderheit des Bauteils:** beide Leuchtdiodenchips getrennt ansteuerbar, hohe Signalwirkung durch Farbwechsel der LED möglich
- **Wellenlänge:** 628 nm (super-rot), 606 nm (orange), 590 nm (gelb), 570 nm (grün), 560 nm (pure green)
- **Abstrahlwinkel:** Lambertscher Strahler (120°)
- **Technologie:** GaAlP (super-rot, orange, gelb, grün), GaP (pure green)
- **optischer Wirkungsgrad:** 1,5 lm/W (super-rot, orange, gelb), 2,5 lm/W (grün), 0,6 lm/W (pure green)
- **Gruppierungsparameter:** Lichtstärke
- **Verarbeitungsmethode:** für alle SMT-Bestücktechniken geeignet
- **Lötmethode:** IR Reflow Löten und Wellenlöten (TTW)
- **Vorbehandlung:** nach JEDEC Level 2
- **Gurtung:** 8-mm Gurt mit 2000/Rolle, ø180 mm oder 8000/Rolle, ø330 mm

Anwendungen

- Informationsanzeigen im Innen- und Außenbereich
- optischer Indikator
- Hinterleuchtung (Schalter, Tasten, Displays, Werbebeleuchtung, Allgemeinbeleuchtung)
- Innenbeleuchtung im Automobilbereich (z. B. Instrumentenbeleuchtung)
- Markierungsbeleuchtung (z.B. Stufen, Fluchtwege, u.ä.)
- Einkopplung in Lichtleiter
- Laufschriftanzeigen
- Signal- und Symbolleuchten

Features

- **package:** white P-LCC-4 package, colorless clear resin
- **feature of the device:** both chips can be controlled separately, high signal efficiency possible by color change of the LED
- **wavelength:** 628 nm (super-red), 606 nm (orange), 590 nm (yellow), 570 nm (green), 560 nm (pure green)
- **viewing angle:** Lambertian Emitter (120°)
- **technology:** GaAlP (super-red, orange, yellow, green), GaP (pure green)
- **optical efficiency:** 1.5 lm/W (super-red, orange, yellow), 2.5 lm/W (green), 0.6 lm/W (pure green)
- **grouping parameter:** luminous intensity
- **assembly methods:** suitable for all SMT assembly methods
- **soldering methods:** IR reflow soldering and TTW soldering
- **preconditioning:** acc. to JEDEC Level 2
- **taping:** 8 mm tape with 2000/reel, ø180 mm or 8000/reel, ø330 mm

Applications

- indoor and outdoor displays
- optical indicators
- backlighting (switches, keys, displays, illuminated advertising, general lighting)
- interior automotive lighting (e.g. dashboard backlighting)
- marker lights (e.g. steps, exit ways, etc.)
- coupling into light guides
- light writing displays
- signal and symbol luminaire

Bestellinformation
Ordering Information

Typ Type	Emissions- farbe Color of Emission	Lichtstärke ¹⁾ Seite 15 Luminous Intensity ¹⁾ page 15 $I_F = 10 \text{ mA}$ I_V (mcd)		Bestellnummer Ordering Code
		color 1	color 2	
		LSG T670-HL-1+HL-1	super-red / green	
LSP T670-HK-1+GK-1	super-red / pure green	2.8 ... 11.2	1.8 ... 11.2	Q62703Q4318
LSY T670-JL-1+JL-1	super-red / yellow	4.5 ... 18.0	4.5 ... 18.0	Q62703Q4317
LOP T670-JK-1+GJ-1	orange / pure green	4.5 ... 11.2	1.8 ... 7.1	Q65110A0466
LYG T670-JL-1+JL-1	yellow / green	4.5 ... 18.0	4.5 ... 18.0	Q62703Q4502

Anm.: Streuung der Lichtstärke in einer Verpackungseinheit $I_{V \max} / I_{V \min} \leq 2.0$
 Streuung der Lichtstärke in einer LED $I_{V \max} / I_{V \min} \leq 3.0$ (LSG T670, LSY T670),
 ≤ 4.0 (LSP T670, LOP T670)

Note: Luminous intensity ratio in one packaging unit $I_{V \max} / I_{V \min} \leq 2.0$
 Luminous intensity ratio in one LED $I_{V \max} / I_{V \min} \leq 3.0$ (LSG T670, LSY T670),
 ≤ 4.0 (LSP T670, LOP T670)

Grenzwerte
Maximum Ratings

Bezeichnung Parameter	Symbol Symbol	Wert Value		Einheit Unit
		super red	pure green	
Betriebstemperatur Operating temperature range	T_{op}	- 40 ... + 100		°C
Lagertemperatur Storage temperature range	T_{stg}	- 40 ... + 100		°C
Sperrschichttemperatur Junction temperature	T_j	+ 100		°C
Durchlassstrom Forward current ($T_A=25^\circ\text{C}$)	I_F	30		mA
Stoßstrom Surge current $t \leq 10 \mu\text{s}, D = 0.005, T_A=25^\circ\text{C}$	I_{FM}	0.5		A
Sperrspannung ^{2) Seite 15} Reverse voltage ^{2) page 15} ($T_A=25^\circ\text{C}$)	V_R	12		V
Leistungsaufnahme Power consumption ($T_A=25^\circ\text{C}$)	P_{tot}	95	90	mW
Wärmewiderstand Thermal resistance				
Sperrschicht / Umgebung ^{3) Seite 15} Junction / air ^{3) page 15}	1 chip on $R_{th JA}$	480		K/W
	2 chips on $R_{th JA}$	650		K/W
Sperrschicht / Löt看 Junction / solder point	1 chip on $R_{th JS}$	260		K/W
	2 chips on $R_{th JS}$	430		K/W

Kennwerte
Characteristics

($T_A = 25\text{ °C}$)

Bezeichnung Parameter	Symbol Symbol	Wert Value					Einheit Unit
		super red	orange	yellow	green	pure green	
Wellenlänge des emittierten Lichtes (typ.) Wavelength at peak emission $I_F = 10\text{ mA}$	λ_{peak}	635	610	586	572	557	nm
Dominantwellenlänge ^{4) Seite 15} Dominant wavelength ^{4) page 15} $I_F = 10\text{ mA}$	λ_{dom}	628 ± 6	606 ± 6	590 ± 6	570 ± 6	560 ± 6	nm
Spektrale Bandbreite bei 50 % $I_{\text{rel max}}$ (typ.) Spectral bandwidth at 50 % $I_{\text{rel max}}$ $I_F = 10\text{ mA}$	$\Delta\lambda$	45	40	45	25	22	nm
Abstrahlwinkel bei 50 % I_V (Vollwinkel) (typ.) Viewing angle at 50 % I_V	2ϕ	120	120	120	120	120	Grad deg.
Durchlassspannung ^{5) Seite 15} (typ.) Forward voltage ^{5) page 15} (max.) $I_F = 10\text{ mA}$	V_F V_F	2.0 2.5	2.0 2.5	2.0 2.5	2.0 2.5	2.0 2.5	V V
Sperrstrom (typ.) Reverse current (max.) $V_R = 12\text{ V}$	I_R I_R	0.01 10	0.01 10	0.01 10	0.01 10	0.01 10	μA μA
Temperaturkoeffizient von λ_{peak} (typ.) Temperature coefficient of λ_{peak} $I_F = 10\text{ mA}; -10\text{ °C} \leq T \leq 100\text{ °C}$	$TC_{\lambda_{\text{peak}}}$	0.11	0.12	0.10	0.11	0.11	nm/K
Temperaturkoeffizient von λ_{dom} (typ.) Temperature coefficient of λ_{dom} $I_F = 10\text{ mA}; -10\text{ °C} \leq T \leq 100\text{ °C}$	$TC_{\lambda_{\text{dom}}}$	0.07	0.07	0.07	0.07	0.05	nm/K
Temperaturkoeffizient von V_F (typ.) Temperature coefficient of V_F $I_F = 10\text{ mA}; -10\text{ °C} \leq T \leq 100\text{ °C}$	TC_V	-1.9	-1.9	-1.9	-1.4	-2.1	mV/K
Optischer Wirkungsgrad (typ.) Optical efficiency $I_F = 10\text{ mA}$	η_{opt}	1.5	1.5	1.5	2.5	0.6	lm/W

Helligkeits-Gruppierungsschema
Brightness Groups

Helligkeitsgruppe Brightness Group	Lichtstärke ^{1) Seite 15} Luminous Intensity ^{1) page 15}	Lichtstrom ^{6) Seite 15} Luminous Flux ^{6) page 15}
	I_V (mcd)	Φ_V (lm)
G	1.8 ... 2.8	7 (typ.)
H	2.8 ... 4.5	11 (typ.)
J	4.5 ... 7.1	17 (typ.)
K	7.1 ... 11.2	27 (typ.)
L	11.2 ... 18.0	35 (typ.)

Anm.: Die Standardlieferform von Serientypen beinhaltet eine Familiengruppe. Einzelne Helligkeitsgruppen sind nicht bestellbar.

Note: The standard shipping format for serial types includes a family group. Individual brightness groups cannot be ordered.

Gruppenbezeichnung auf Etikett
Group Name on Label

Beispiel: J-1+K-1

Example: J-1+K-1

Helligkeits- gruppe	Wellenlänge (keine Gruppierung)	Helligkeits- gruppe	Wellenlänge (keine Gruppierung)
Brightness Group	Wavelength (no grouping)	Brightness Group	Wavelength (no grouping)
(yellow)	(yellow)	(green)	(green)
J	1	K	1

Anm.: In einer Verpackungseinheit / Gurt ist immer nur eine Helligkeitsgruppe pro Farbe enthalten.

Note: No packing unit / tape ever contains more than one brightness group per color.

Relative spektrale Emission^{6) Seite 15}

Relative Spectral Emission^{6) page 15}

$V(\lambda)$ = spektrale Augenempfindlichkeit / Standard eye response curve

$I_{rel} = f(\lambda); T_A = 25\text{ °C}; I_F = 10\text{ mA}$

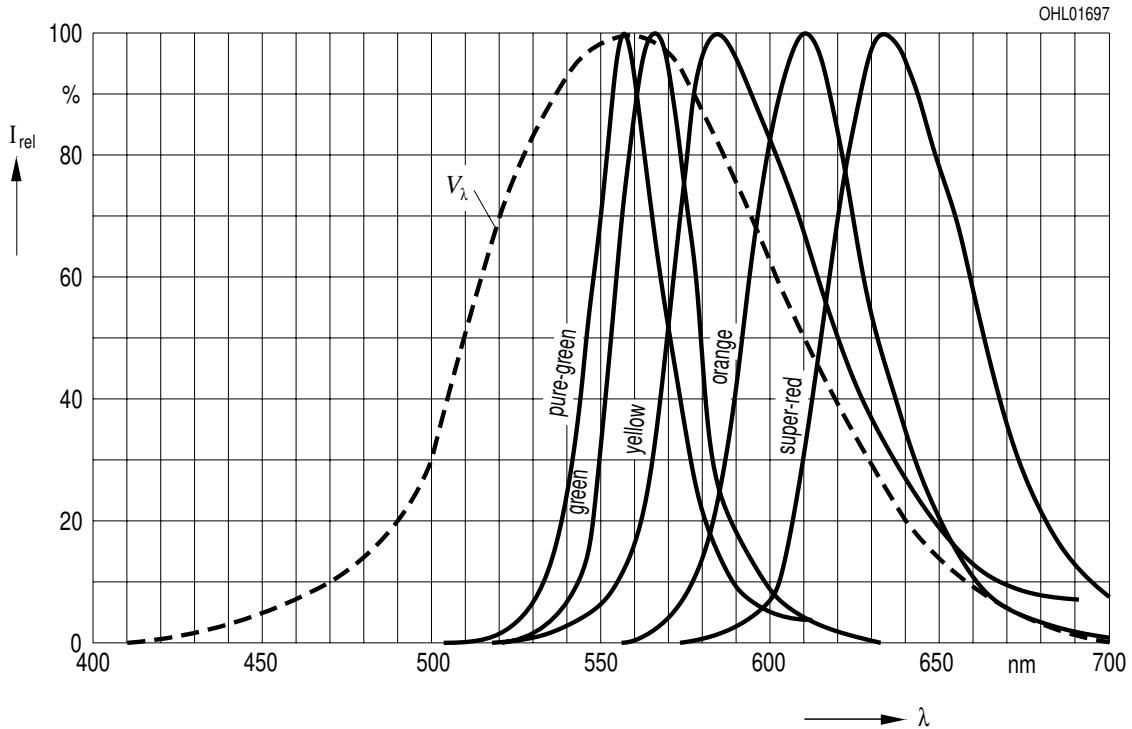

Abstrahlcharakteristik^{6) Seite 15}

Radiation Characteristic^{6) page 15}

$I_{rel} = f(\varphi); T_A = 25\text{ °C}$

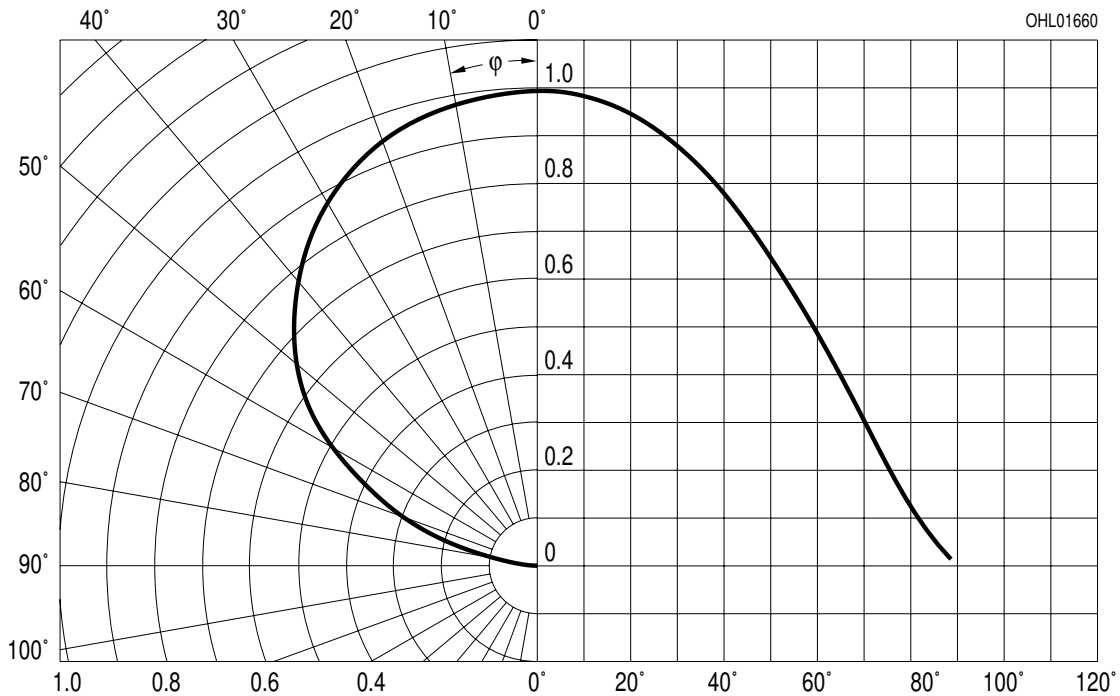

Durchlassstrom ^{6) 7) Seite 15}

Forward Current ^{6) 7) page 15}

$$I_F = f(V_F); T_A = 25\text{ }^\circ\text{C}$$

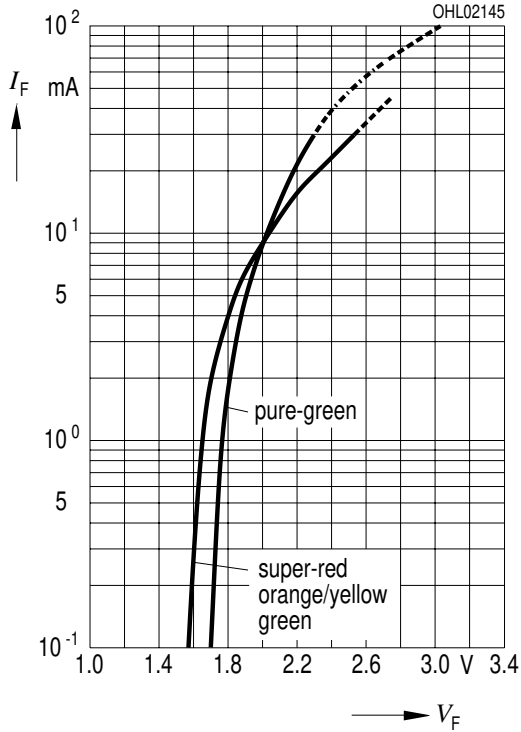

Relative Lichtstärke ^{6) 7) Seite 15}

Relative Luminous Intensity ^{6) 7) page 15}

$$I_V/I_{V(10\text{ mA})} = f(I_F); T_A = 25\text{ }^\circ\text{C}$$

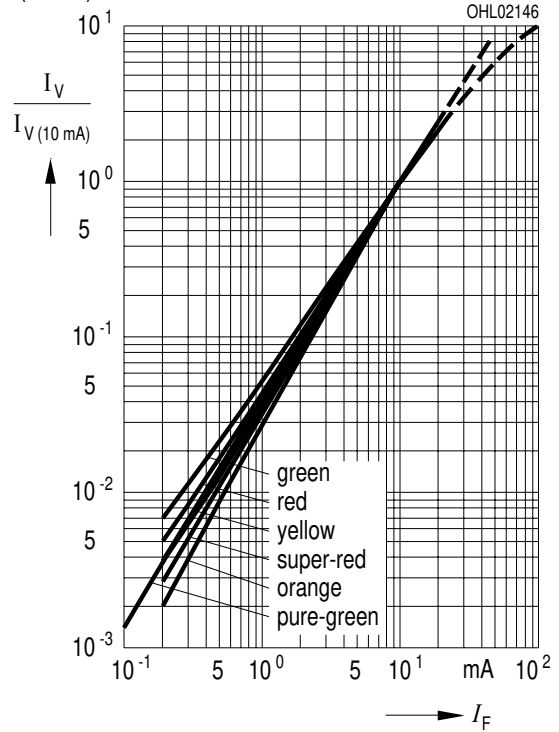

Relative Lichtstärke ^{6) Seite 15}

Relative Luminous Intensity ^{6) page 15}

$$I_V/I_{V(25\text{ }^\circ\text{C})} = f(T_j); I_F = 10\text{ mA}$$

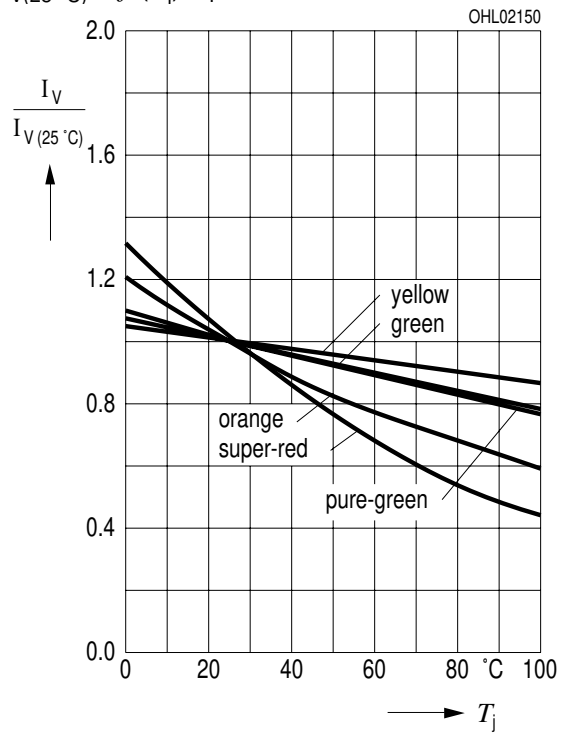

Maximal zulässiger Durchlassstrom
Max. Permissible Forward Current

$I_F = f(T)$

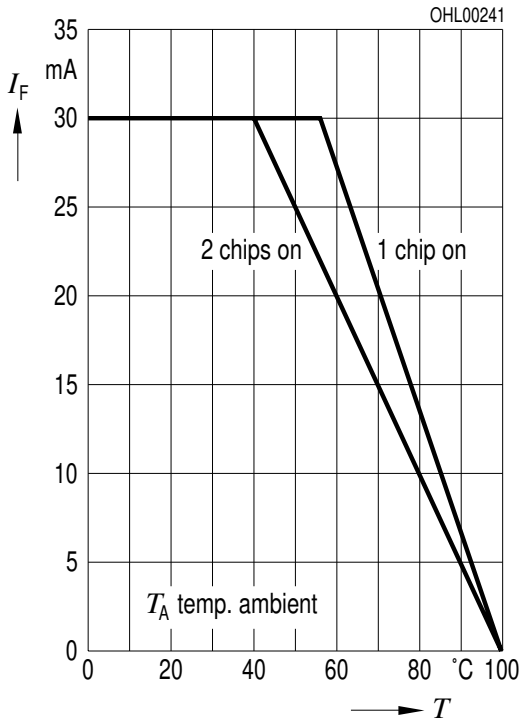

Maximal zulässiger Durchlassstrom
Max. Permissible Forward Current

$I_F = f(T)$

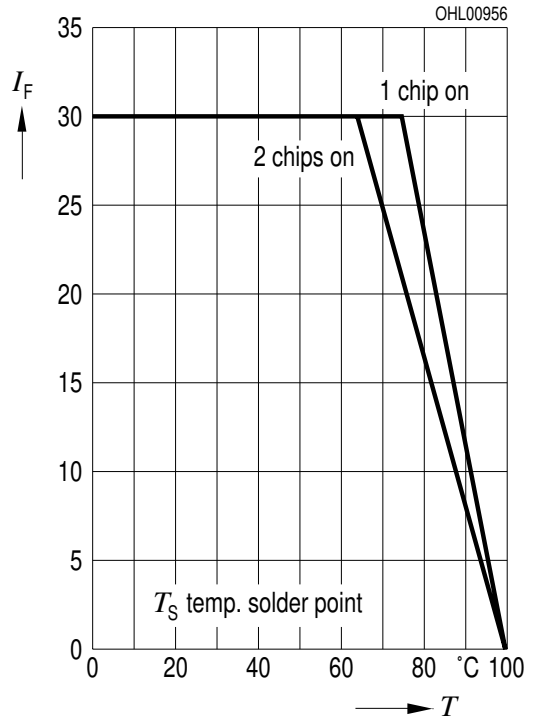

Zulässige Impulsbelastbarkeit $I_F = f(t_p)$
Permissible Pulse Handling Capability

Duty cycle $D =$ parameter, $T_A = 25\text{ °C}$

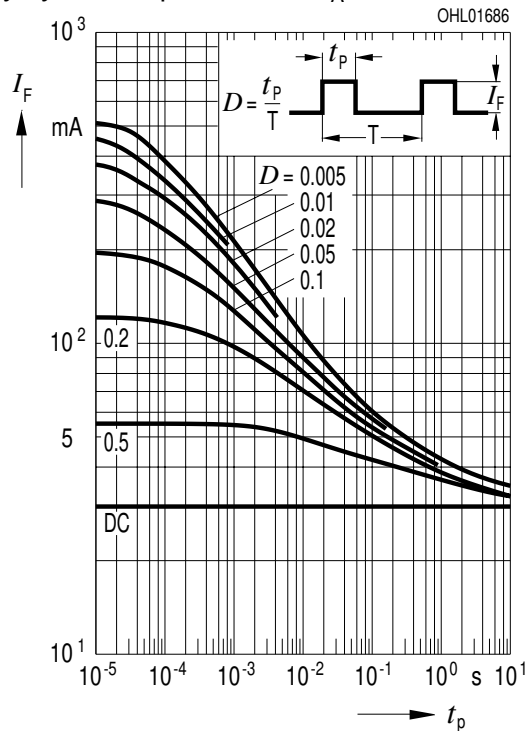

Maßzeichnung⁸⁾ Seite 15
 Package Outlines⁸⁾ page 15

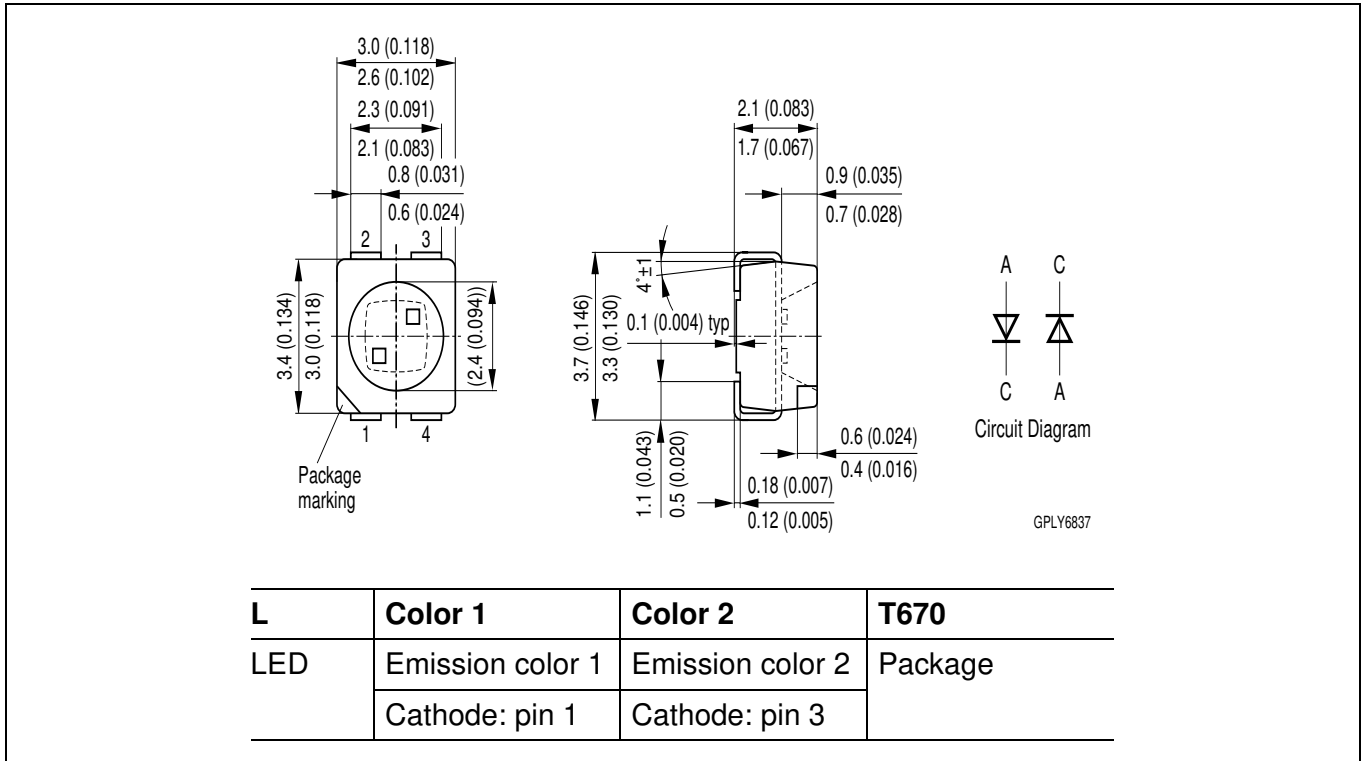

Kathodenkennung: abgeschrägte Ecke
Cathode mark: bevelled edge
Gewicht / Approx. weight: 35 mg

Gurtung / Polarität und Lage⁸⁾ Seite 15 Verpackungseinheit 2000/Rolle, ø180 mm
 oder 8000/Rolle, ø330 mm

Method of Taping / Polarity and Orientation⁸⁾ page 15 Packing unit 2000/reel, ø180 mm
 or 8000/reel, ø330 mm

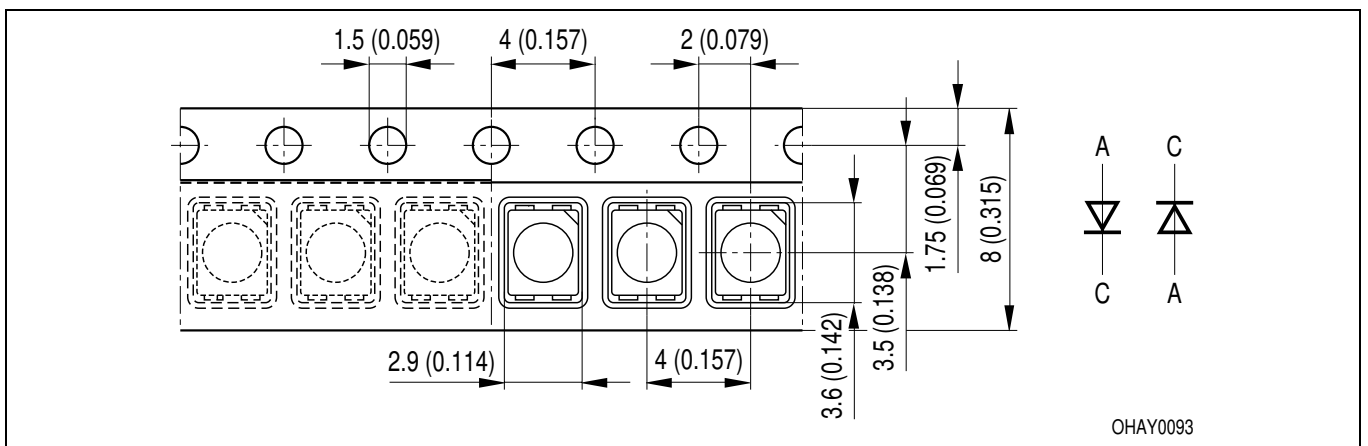

Empfohlenes Lötpad Design⁸⁾ Seite 15
Recommended Solder Pad⁸⁾ page 15

IR Reflow Löten
 IR Reflow Soldering

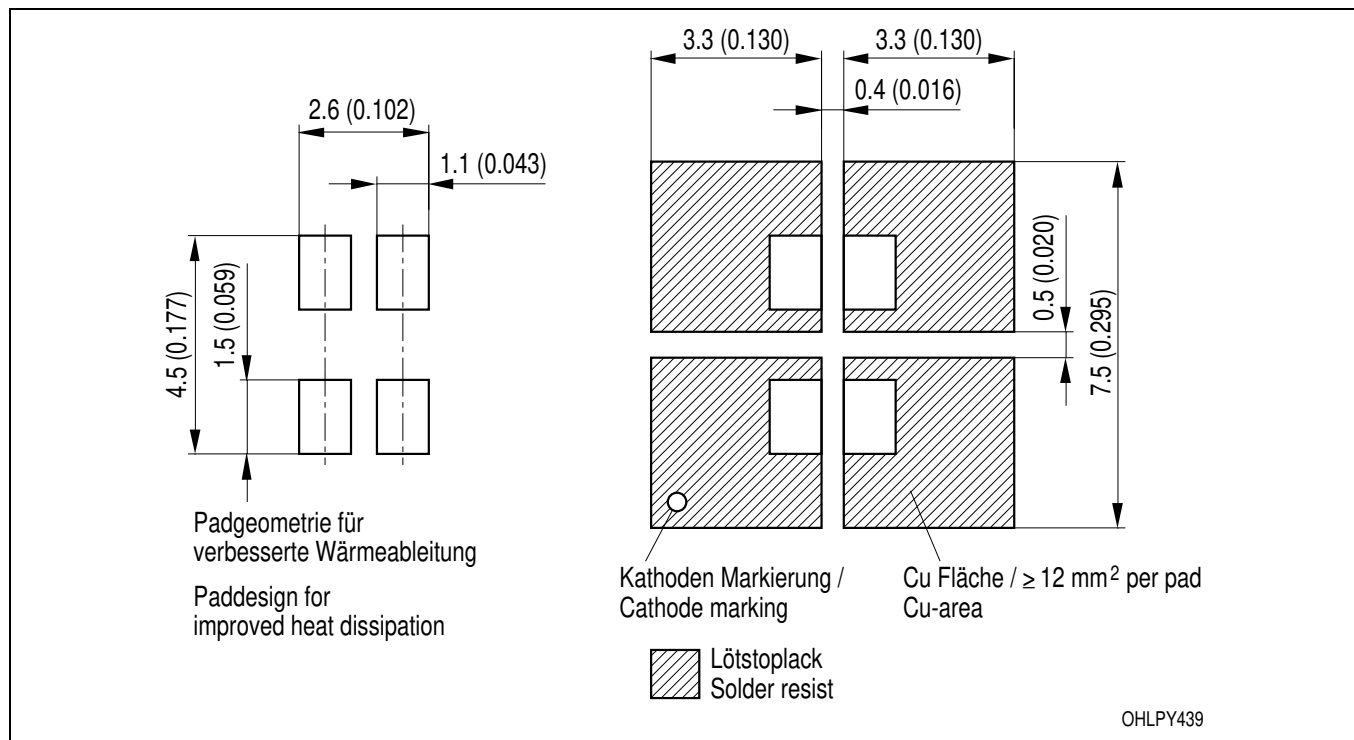

Empfohlenes Lötpad Design⁸⁾ Seite 15
Recommended Solder Pad⁸⁾ page 15

Wellenlöten (TTW)
 TTW Soldering

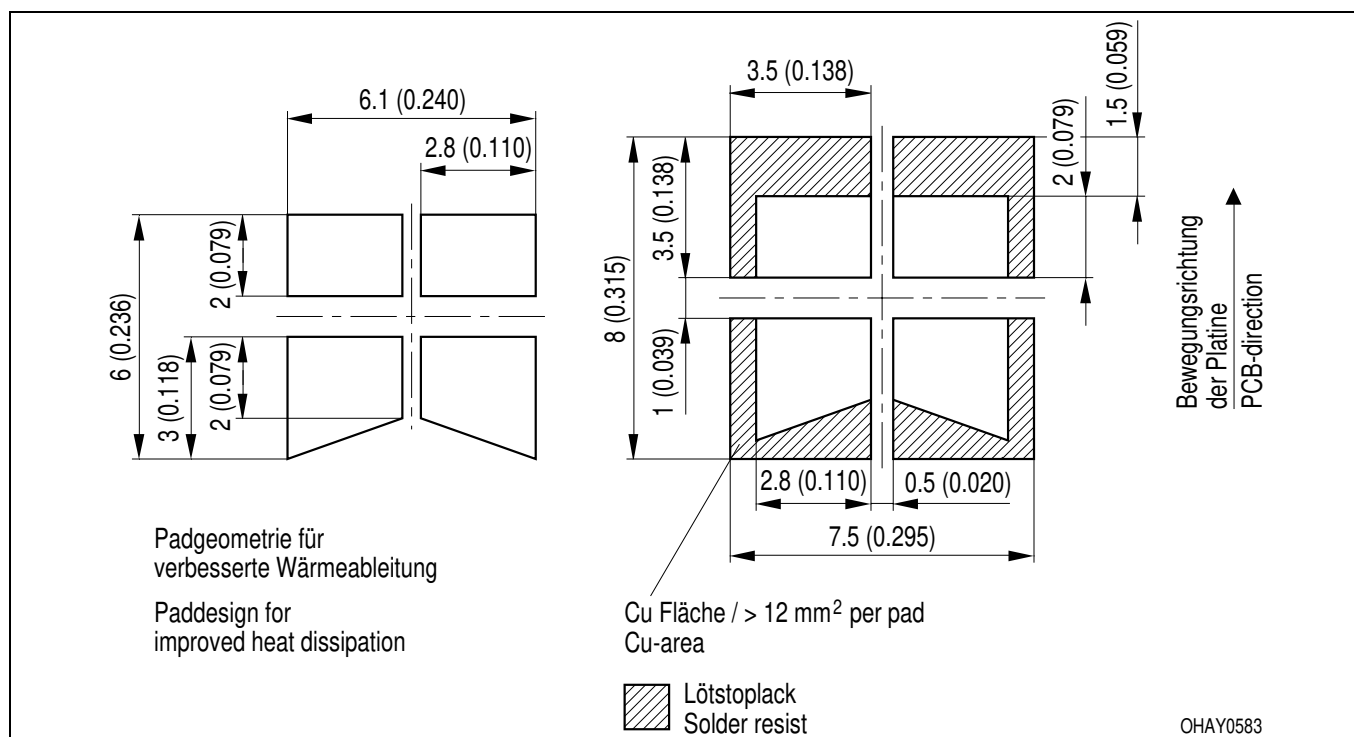

Lötbedingungen
Soldering Conditions

Vorbehandlung nach JEDEC Level 2
Preconditioning acc. to JEDEC Level 2

IR-Reflow Lötprofil
IR Reflow Soldering Profile

(nach IPC 9501)
(acc. to IPC 9501)

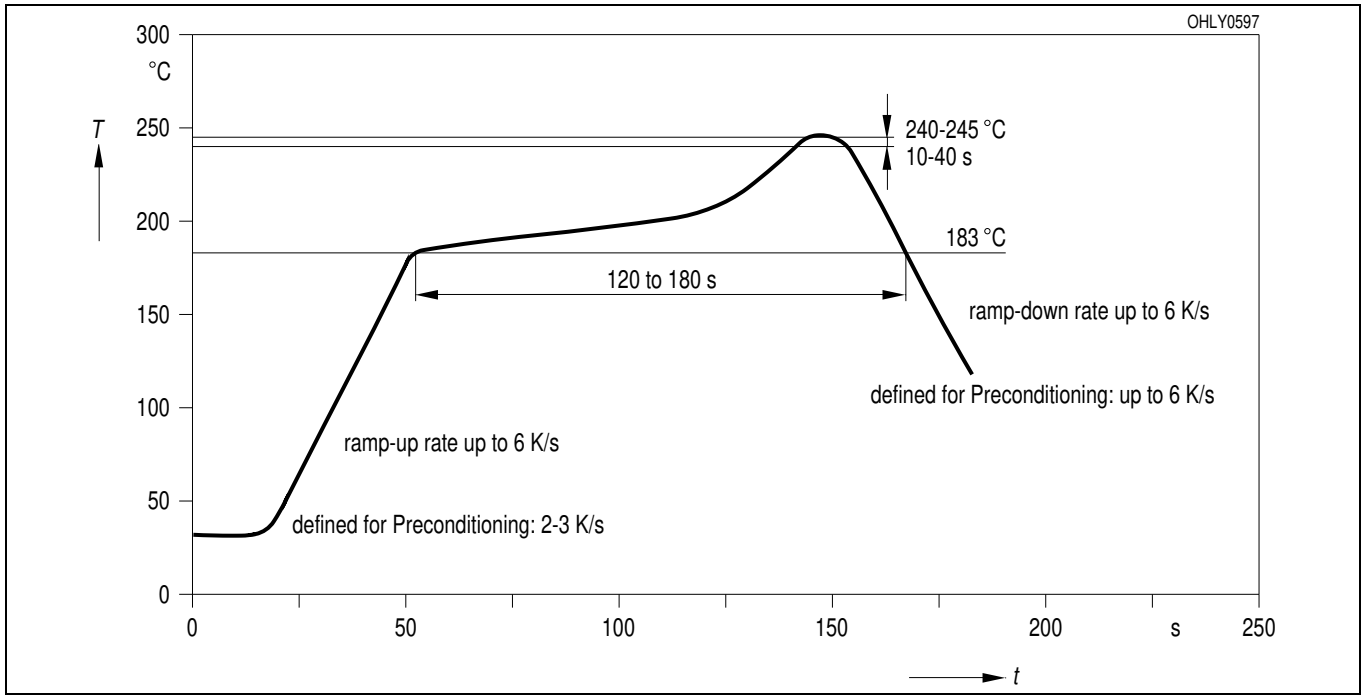

Wellenlöten (TTW)
TTW Soldering

(nach CECC 00802)
(acc. to CECC 00802)

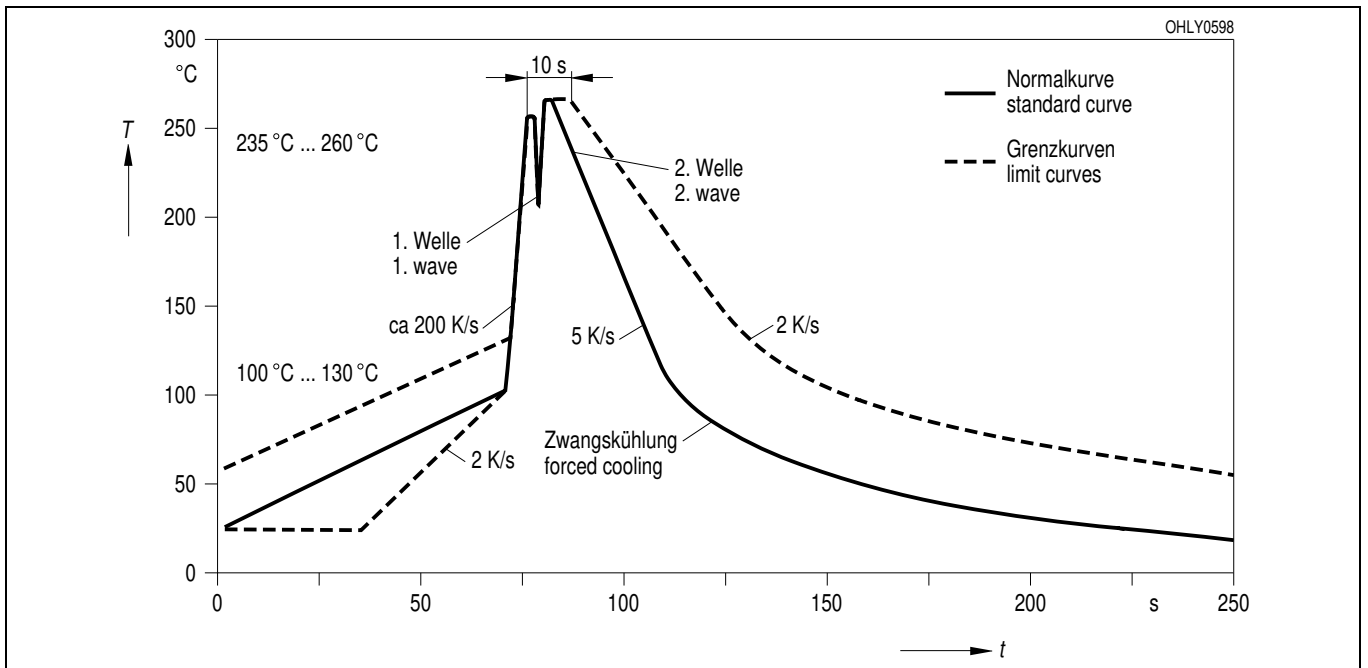

Barcode-Produkt-Etikett (BPL)

Barcode-Product-Label (BPL)

OSRAM Opto Semiconductors

Lx xxxx Bin1: Bin Information Color 1
 Product Name Bin2:
 Bin3:

(6P) BATCH NO: Batch Number
Bar Code

(1T) LOT NO: Lot Number (9D) D/C: Date Code
Bar Code

(X) PROD NO: Product Code (Q) QTY: Product Quantity per Reel (G) GROUP: X - X - X
Bar Code

ML Temp ST
 2 245 C R
 2 260 C T

Additional TEXT
 R077 DEMY
 PACKVAR: Packing Type

Forward Voltage Rank
 Wavelength Rank
 Brightness Rank

OHA02043

Gurtverpackung

Tape and Reel

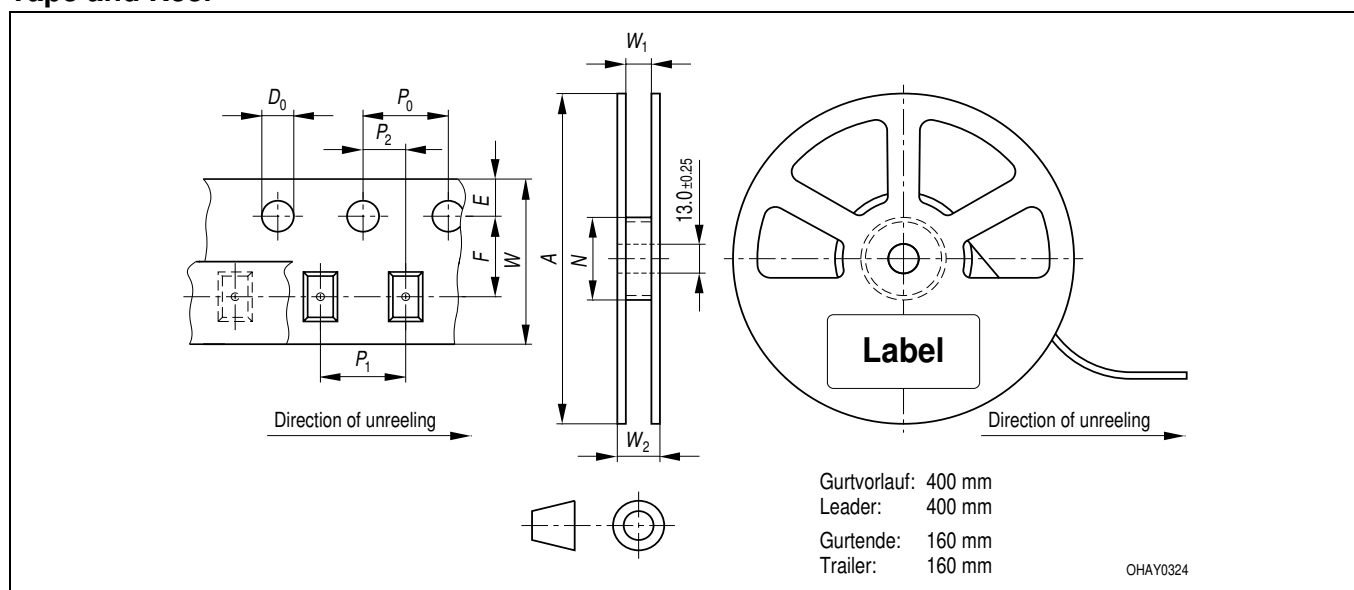

Tape dimensions in mm (inch)

W	P ₀	P ₁	P ₂	D ₀	E	F
8 ^{+0.3} -0.1	4 ± 0.1 (0.157 ± 0.004)	4 ± 0.1 (0.157 ± 0.004)	2 ± 0.05 (0.079 ± 0.002)	1.5 ± 0.1 (0.059 ± 0.004)	1.75 ± 0.1 (0.069 ± 0.004)	3.5 ± 0.05 (0.138 ± 0.002)

Reel dimensions in mm (inch)

A	W	N _{min}	W ₁	W _{2 max}
180 (7)	8 (0.315)	60 (2.362)	8.4 + 2 (0.331 + 0.079)	14.4 (0.567)
330 (13)	8 (0.315)	60 (2.362)	8.4 + 2 (0.331 + 0.079)	14.4 (0.567)

Trockenverpackung und Materialien
Dry Packing Process and Materials

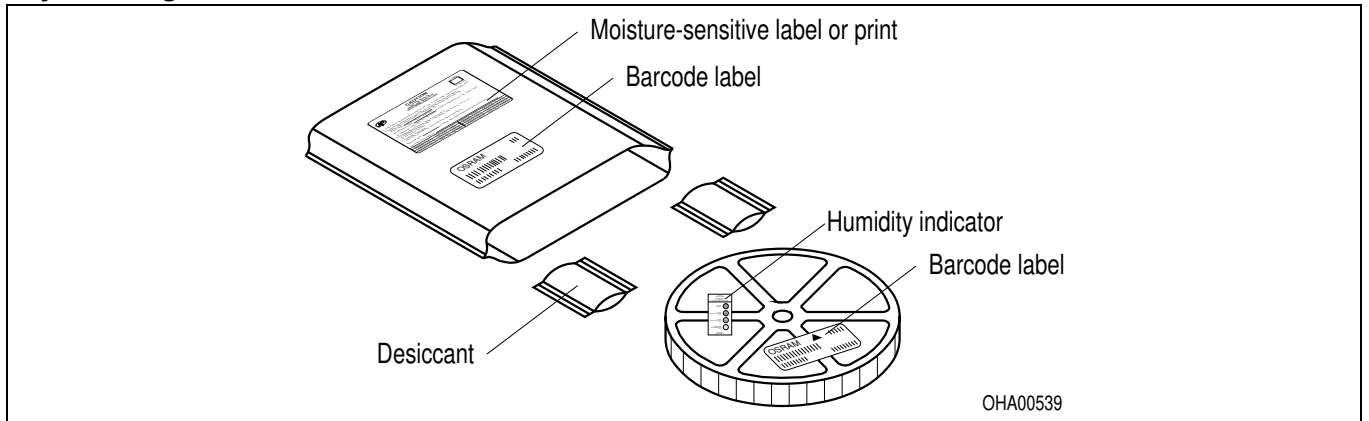

Anm.: Feuchteempfindliche Produkte sind verpackt in einem Trockenbeutel zusammen mit einem Trockenmittel und einer Feuchteindikatorkarte
Bezüglich Trockenverpackung finden Sie weitere Hinweise im Internet und in unserem Short Form Catalog im Kapitel "Gurtung und Verpackung" unter dem Punkt "Trockenverpackung". Hier sind Normenbezüge, unter anderem ein Auszug der JEDEC-Norm, enthalten.

Note: Moisture-sensitive product is packed in a dry bag containing desiccant and a humidity card.
Regarding dry pack you will find further information in the internet and in the Short Form Catalog in chapter "Tape and Reel" under the topic "Dry Pack". Here you will also find the normative references like JEDEC.

Kartonverpackung und Materialien
Transportation Packing and Materials

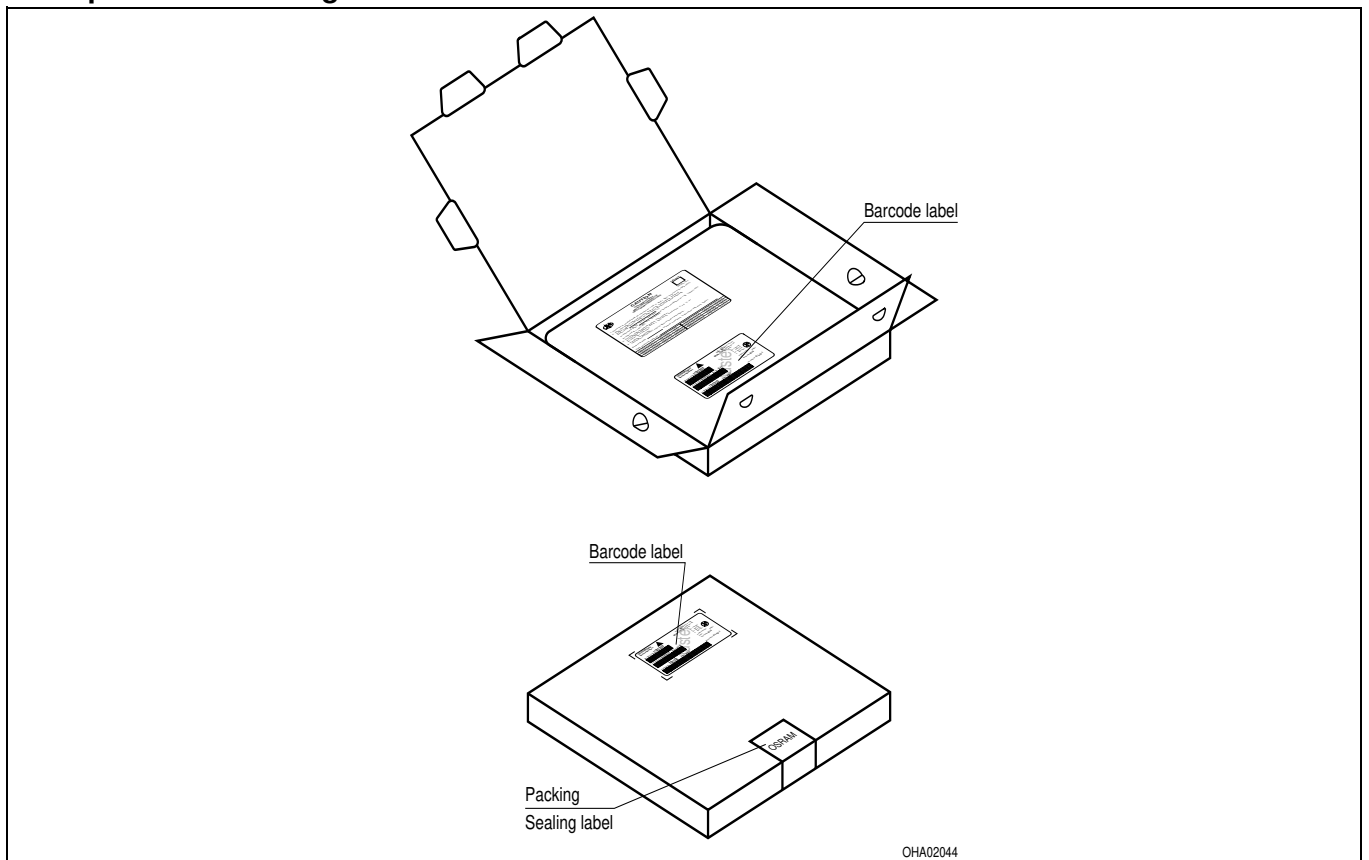

Revision History: 2005-04-05

Previous Version: 2004-08-13

Page	Subjects (major changes since last revision)	Date of change
3	note changed	
3	luminous Intensity of LOP T670 for pure green	
5	dominant wavelength (yellow)	
13	graphic (taping)	
5	value (wavelength yellow)	
14	annotations	2002-07-23
4, 5	value (reverse voltage from 5 V to 12 V)	2002-09-18
3	ambient temperature	2003-09-09
all	new template	2004-03-11
all	Discontinuation of non-RoHS compliant product versions	2005-04-05

Attention please!

The information describes the type of component and shall not be considered as assured characteristics. Terms of delivery and rights to change design reserved. Due to technical requirements components may contain dangerous substances. For information on the types in question please contact our Sales Organization. If printed or downloaded, please find the latest version in the Internet.

Packing

Please use the recycling operators known to you. We can also help you – get in touch with your nearest sales office. By agreement we will take packing material back, if it is sorted. You must bear the costs of transport. For packing material that is returned to us unsorted or which we are not obliged to accept, we shall have to invoice you for any costs incurred.

Components used in life-support devices or systems must be expressly authorized for such purpose! Critical components^{9) page 15} may only be used in life-support devices or systems^{10) page 15} with the express written approval of OSRAM OS.

Fußnoten:

- 1) Helligkeitswerte werden mit einer Stromeinprägedauer von 25 ms und einer Genauigkeit von $\pm 11\%$ ermittelt.
- 2) Die LED kann kurzzeitig in Sperrichtung betrieben werden.
- 3) R_{thJA} ergibt sich bei Montage auf PC-Board FR 4 (Padgröße $\geq 16 \text{ mm}^2$ je Pad)
- 4) Wellenlängen werden mit einer Stromeinprägedauer von 25 ms und einer Genauigkeit von $\pm 1 \text{ nm}$ ermittelt.
- 5) Spannungswerte werden mit einer Stromeinprägedauer von 1 ms und einer Genauigkeit von $\pm 0,1 \text{ V}$ ermittelt.
- 6) Wegen der besonderen Prozessbedingungen bei der Herstellung von LED können typische oder abgeleitete technische Parameter nur aufgrund statistischer Werte wiedergegeben werden. Diese stimmen nicht notwendigerweise mit den Werten jedes einzelnen Produktes überein, dessen Werte sich von typischen und abgeleiteten Werten oder typischen Kennlinien unterscheiden können. Falls erforderlich, z.B. aufgrund technischer Verbesserungen, werden diese typischen Werte ohne weitere Ankündigung geändert.
- 7) Im gestrichelten Bereich der Kennlinien muss mit erhöhten Helligkeitsunterschieden zwischen Leuchtdioden innerhalb einer Verpackungseinheit gerechnet werden.
- 8) Maße werden wie folgt angegeben: mm (inch)
- 9) Ein kritisches Bauteil ist ein Bauteil, das in lebenserhaltenden Apparaten oder Systemen eingesetzt wird und dessen Defekt voraussichtlich zu einer Fehlfunktion dieses lebenserhaltenden Apparates oder Systems führen wird oder die Sicherheit oder Effektivität dieses Apparates oder Systems beeinträchtigt.
- 10) Lebenserhaltende Apparate oder Systeme sind für
 - (a) die Implantierung in den menschlichen Körper oder
 - (b) für die Lebenserhaltung bestimmt.Falls sie versagen, kann davon ausgegangen werden, dass die Gesundheit und das Leben des Patienten in Gefahr ist.

Remarks:

- 1) Brightness groups are tested at a current pulse duration of 25 ms and a tolerance of $\pm 11\%$.
- 2) Driving the LED in reverse direction is suitable for short term application.
- 3) R_{thJA} results from mounting on PC board FR 4 (pad size $\geq 16 \text{ mm}^2$ per pad)
- 4) Wavelengths are tested at a current pulse duration of 25 ms and a tolerance of $\pm 1 \text{ nm}$.
- 5) Forward voltages are tested at a current pulse duration of 1 ms and a tolerance of $\pm 0.1 \text{ V}$.
- 6) Due to the special conditions of the manufacturing processes of LED, the typical data or calculated correlations of technical parameters can only reflect statistical figures. These do not necessarily correspond to the actual parameters of each single product, which could differ from the typical data and calculated correlations or the typical characteristic line. If requested, e.g. because of technical improvements, these typ. data will be changed without any further notice.
- 7) In the range where the line of the graph is broken, you must expect higher brightness differences between single LEDs within one packing unit.
- 8) Dimensions are specified as follows: mm (inch)
- 9) A critical component is a component used in a life-support device or system whose failure can reasonably be expected to cause the failure of that life-support device or system, or to affect its safety or the effectiveness of that device or system.
- 10) Life support devices or systems are intended
 - (a) to be implanted in the human body,
 - or
 - (b) to support and/or maintain and sustain human life.If they fail, it is reasonable to assume that the health and the life of the user may be endangered.