



Chipsmall Limited consists of a professional team with an average of over 10 year of expertise in the distribution of electronic components. Based in Hongkong, we have already established firm and mutual-benefit business relationships with customers from,Europe,America and south Asia,supplying obsolete and hard-to-find components to meet their specific needs.

With the principle of “Quality Parts,Customers Priority,Honest Operation,and Considerate Service”,our business mainly focus on the distribution of electronic components. Line cards we deal with include Microchip,ALPS,ROHM,Xilinx,Pulse,ON,Everlight and Freescale. Main products comprise IC,Modules,Potentiometer,IC Socket,Relay,Connector.Our parts cover such applications as commercial,industrial, and automotives areas.

We are looking forward to setting up business relationship with you and hope to provide you with the best service and solution. Let us make a better world for our industry!



Contact us

Tel: +86-755-8981 8866 Fax: +86-755-8427 6832

Email & Skype: info@chipsmall.com Web: www.chipsmall.com

Address: A1208, Overseas Decoration Building, #122 Zhenhua RD., Futian, Shenzhen, China



Power TOPLED® Enhanced Optical Power LED (ATON®)

LB E67C, LV E67C, LT E67C



**Non-RoHS compliant version of product will be discontinued acc. to OS-PD-2005-005.
The product itself will remain within RoHS compliant version.**

Besondere Merkmale

- **Gehäusertyp:** weißes P-LCC-4 Gehäuse, farbloser klarer Verguss
- **Besonderheit des Bauteils:** mehr Licht durch erhöhten optischen Wirkungsgrad; höhere Umgebungstemperatur bei gleichem Strom im Vergleich zur TOPLED® möglich
- **Wellenlänge:** 469 nm (blau), 503 nm (verde), 525 nm (true green)
- **Abstrahlwinkel:** Lambertscher Strahler (120°)
- **Technologie:** InGaN
- **optischer Wirkungsgrad:** 3 lm/W (blau), 10 lm/W (verde), 13 lm/W (true green)
- **Gruppierungsparameter:** Lichtstärke, Wellenlänge
- **Verarbeitungsmethode:** für alle SMT-Bestücktechniken geeignet
- **Lötmethode:** IR Reflow Löten und Wellenlöten (TTW)
- **Vorbehandlung:** nach JEDEC Level 2
- **Gurtung:** 8-mm Gurt mit 2000/Rolle, ø180 mm oder 8000/Rolle, ø330 mm
- **ESD-Festigkeit:** ESD-sicher bis 2 kV nach JESD22-A114-B

Anwendungen

- Ampelanwendung (verde)
- Hinterleuchtung (LCD, Schalter, Tasten, Displays, Werbebeleuchtung, Allgemeinbeleuchtung)
- Innenbeleuchtung im Automobilbereich (z.B. Instrumentenbeleuchtung, u. ä.)
- Ersatz von Kleinst-Glühlampen
- Markierungsbeleuchtung (z.B. Stufen, Fluchtwege, u.ä.)
- Signal- und Symbolleuchten
- Scanner

Features

- **package:** white P-LCC-4 package, colorless clear resin
- **feature of the device:** more light due to higher optical efficiency; higher ambient temperature at the same current possible compared to TOPLED®
- **wavelength:** 469 nm (blue), 503 nm (verde), 525 nm (true green)
- **viewing angle:** Lambertian Emitter (120°)
- **technology:** InGaN
- **optical efficiency:** 3 lm/W (blue), 10 lm/W (verde), 13 lm/W (true green)
- **grouping parameter:** luminous intensity, wavelength
- **assembly methods:** suitable for all SMT assembly methods
- **soldering methods:** IR reflow soldering and TTW soldering
- **preconditioning:** acc. to JEDEC Level 2
- **taping:** 8 mm tape with 2000/reel, ø180 mm or 8000/reel, ø330 mm
- **ESD-withstand voltage:** up to 2 kV acc. to JESD22-A114-B

Applications

- traffic lights (verde)
- backlighting (LCD, switches, keys, displays, illuminated advertising, general lighting)
- interior automotive lighting (e.g. dashboard backlighting, etc.)
- substitution of micro incandescent lamps
- marker lights (e.g. steps, exit ways, etc.)
- signal and symbol luminaire
- scanners

Bestellinformation
Ordering Information

Typ	Emissions- farbe	Lichtstärke ^{1) Seite 17}	Lichtstrom ^{2) Seite 17}	Bestellnummer
Type	Color of Emission	Luminous Intensity ^{1) page 17} $I_F = 30 \text{ mA}$ $I_V \text{ (mcd)}$	Luminous Flux ^{2) page 17} $I_F = 30 \text{ mA}$ $\Phi_V \text{ (mlm)}$	Ordering Code
LB E67C-Q2S1-35	blue	90 ... 224	470 (typ.)	Q62703Q6236
LV E67C-S2T2-35	verde	224 ... 450	1000 (typ.)	Q62703Q6286
LV E67C-T2V1-35		355 ... 900	1900 (typ.)	Q65110A0185
LT E67C-T2V1-35	true green	355 ... 900	1900 (typ.)	Q65110A0274

Anm.: -35 Gesamter Farbbereich, Lieferung in Einzelgruppen (siehe Seite 5)

Note: -35 Total color tolerance range, delivery in single groups (see page 5)

Grenzwerte
Maximum Ratings

Bezeichnung Parameter	Symbol Symbol	Werte Values		Einheit Unit
		LB	LV, LT	
Betriebstemperatur Operating temperature range	T_{op}	- 40 ... + 100		°C
Lagertemperatur Storage temperature range	T_{stg}	- 40 ... + 100		°C
Sperrschichttemperatur Junction temperature	T_j	+ 110	+ 125	°C
Durchlassstrom Forward current ($T_A=25^\circ\text{C}$)	I_F	30		mA
Stoßstrom Surge current $t \leq 10 \mu\text{s}$, $D = 0.005$, $T_A=25^\circ\text{C}$	I_{FM}	300	400	mA
Sperrspannung ^{3) Seite 17} Reverse voltage ^{3) page 17} ($T_A=25^\circ\text{C}$)	V_R	5		V
Leistungsaufnahme Power consumption ($T_A=25^\circ\text{C}$)	P_{tot}	135		mW
Wärmewiderstand Thermal resistance Sperrschicht/Umgebung ^{4) Seite 17} Junction/ambient ^{4) page 17}	$R_{th JA}$	350		K/W
Sperrschicht/Löt看 Junction/solder point	$R_{th JS}$	180		K/W

Kennwerte
Characteristics
 $(T_A = 25\text{ °C})$

Bezeichnung Parameter	Symbol Symbol	Werte Values			Einheit Unit
		LB	LV	LT	
Wellenlänge des emittierten Lichtes (typ.) Wavelength at peak emission $I_F = 30\text{ mA}$	λ_{peak}	464	501	520	nm
Dominantwellenlänge ⁵⁾ Seite 17 Dominant wavelength ⁵⁾ page 17 $I_F = 30\text{ mA}$	λ_{dom}	469* ± 6	503* ± 6	525* ± 9	nm
Spektrale Bandbreite bei 50 % $I_{\text{rel max}}$ (typ.) Spectral bandwidth at 50 % $I_{\text{rel max}}$ $I_F = 30\text{ mA}$	$\Delta\lambda$	25	30	33	nm
Abstrahlwinkel bei 50 % I_V (Vollwinkel) (typ.) Viewing angle at 50 % I_V	2ϕ	120	120	120	Grad deg.
Durchlassspannung ⁶⁾ Seite 17 (min.) Forward voltage ⁶⁾ page 17 (typ.) $I_F = 30\text{ mA}$ (max.)	V_F V_F V_F	3.3 3.9 4.4	3.3 3.8 4.4	3.3 3.8 4.4	V V V
Sperrstrom (typ.) Reverse current (max.) $V_R = 5\text{ V}$	I_R I_R	0.01 10	0.01 10	0.01 10	μA μA
Temperaturkoeffizient von λ_{peak} (typ.) Temperature coefficient of λ_{peak} $I_F = 30\text{ mA}; -10\text{ °C} \leq T \leq 100\text{ °C}$	$TC_{\lambda_{\text{peak}}}$	0.05	0.03	0.04	nm/K
Temperaturkoeffizient von λ_{dom} (typ.) Temperature coefficient of λ_{dom} $I_F = 30\text{ mA}; -10\text{ °C} \leq T \leq 100\text{ °C}$	$TC_{\lambda_{\text{dom}}}$	0.04	0.05	0.05	nm/K
Temperaturkoeffizient von V_F (typ.) Temperature coefficient of V_F $I_F = 30\text{ mA}; -10\text{ °C} \leq T \leq 100\text{ °C}$	TC_V	- 5.0	- 3.6	- 3.6	mV/K
Optischer Wirkungsgrad (typ.) Optical efficiency $I_F = 30\text{ mA}$	η_{opt}	3	10	13	lm/W

* Einzelgruppen siehe Seite 5
Individual groups on page 5

Wellenlängengruppen (Dominantwellenlänge)⁵⁾ Seite 17
Wavelength Groups (Dominant Wavelength)⁵⁾ page 17

Gruppe Group	blue		verde		true green		Einheit Unit
	min.	max.	min.	max.	min.	max.	
3	463	467	497	501	516	522	nm
4	467	471	501	505	522	528	nm
5	471	475	505	509	528	534	nm

Helligkeits-Gruppierungsschema
Brightness Groups

Helligkeitshalbgruppe Brightness Half Group	Lichtstärke ¹⁾ Seite 17 Luminous Intensity ¹⁾ page 17 I_V (mcd)	Lichtstrom ²⁾ Seite 17 Luminous Flux ²⁾ page 17 Φ_V (lm)
P2	56 ... 71	190 (typ.)
Q1	71 ... 90	240 (typ.)
Q2	90 ... 112	300 (typ.)
R1	112 ... 140	380 (typ.)
R2	140 ... 180	480 (typ.)
S1	180 ... 224	600 (typ.)
S2	224 ... 280	760 (typ.)
T1	280 ... 355	950 (typ.)
T2	355 ... 450	1200 (typ.)
U1	450 ... 560	1500 (typ.)
U2	560 ... 710	1900 (typ.)
V1	710 ... 900	2400 (typ.)

Anm.: Die Standardlieferform von Serientypen beinhaltet eine untere bzw. eine obere Familiengruppe. Diese besteht aus 3 bzw. 4 Helligkeitshalbgruppen besteht. Einzelne Helligkeitshalbgruppen sind nicht bestellbar.

Note: The standard shipping format for serial types includes a lower or upper family group of 3 or 4 individual brightness half groups. Individual brightness half groups cannot be ordered.

Gruppenbezeichnung auf Etikett
Group Name on Label

Beispiel: S2-3

Example: S2-3

Helligkeitshalbgruppe Brightness Half Group	Wellenlänge Wavelength
S2	4

Anm.: In einer Verpackungseinheit / Gurt ist immer nur eine Gruppe für jede Selektion enthalten.

Note: No packing unit / tape ever contains more than one group for each selection.

Relative spektrale Emission²⁾ Seite 17

Relative Spectral Emission²⁾ page 17

$V(\lambda)$ = spektrale Augenempfindlichkeit / Standard eye response curve

$I_{rel} = f(\lambda); T_A = 25\text{ }^\circ\text{C}; I_F = 30\text{ mA}$

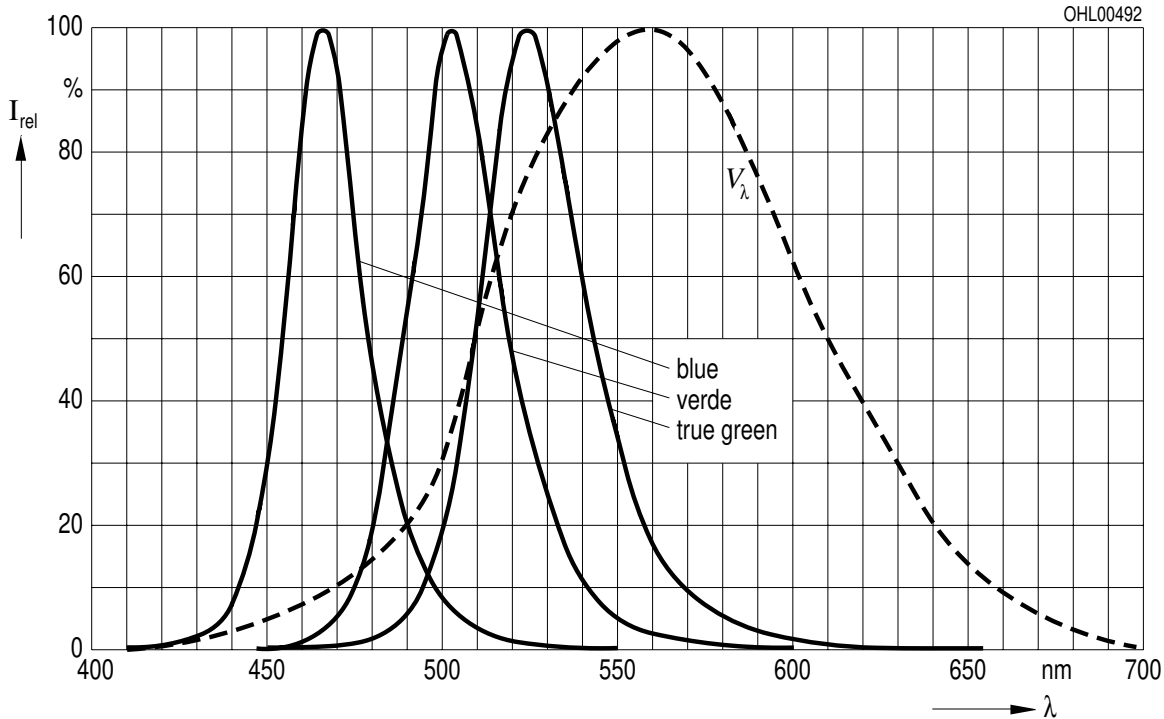

Abstrahlcharakteristik²⁾ Seite 17

Radiation Characteristic²⁾ page 17

$I_{rel} = f(\varphi); T_A = 25\text{ }^\circ\text{C}$

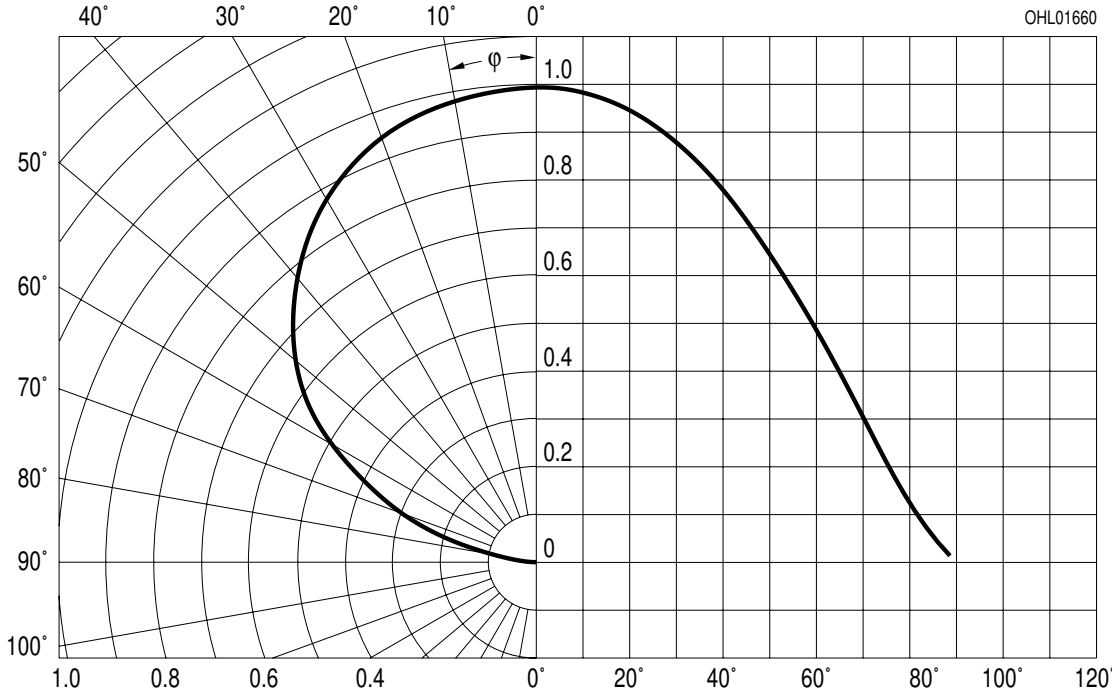

Durchlassstrom²⁾ Seite 17
Forward Current²⁾ page 17

$I_F = f(V_F); T_A = 25\text{ °C}$

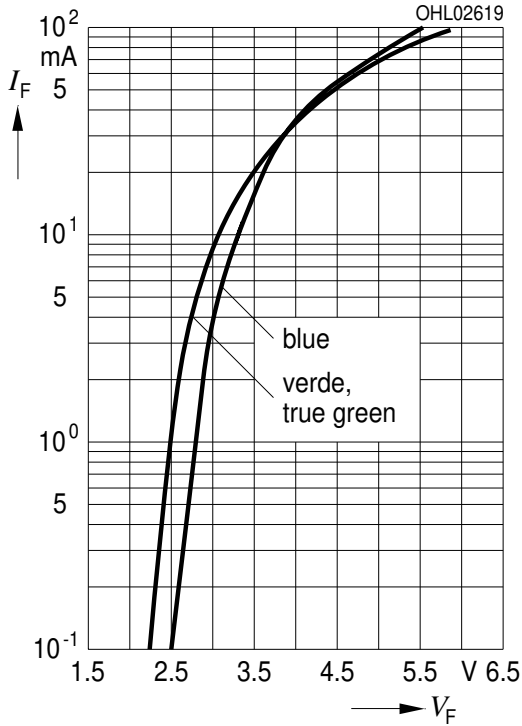

Relative Lichtstärke^{2) 7)} Seite 17
Relative Luminous Intensity^{2) 7)} page 17

$I_V/I_{V(30\text{ mA})} = f(I_F); T_A = 25\text{ °C}$

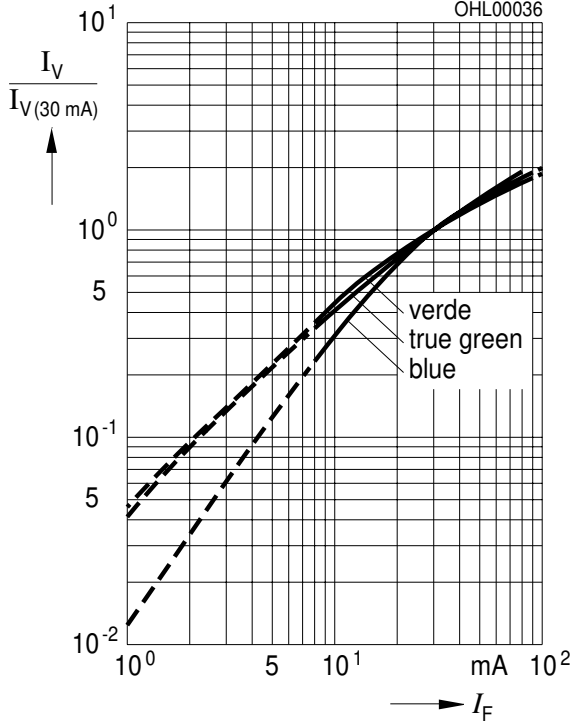

Relative Lichtstärke²⁾ Seite 17
Relative Luminous Intensity²⁾ page 17

$I_V/I_{V(25\text{ °C})} = f(T_j); I_F = 30\text{ mA}$

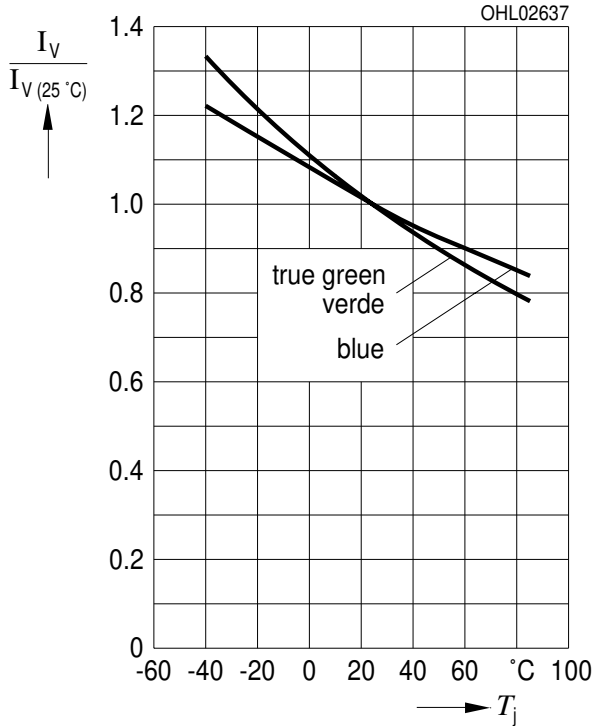

Dominante Wellenlänge²⁾ Seite 17

Dominant Wavelength²⁾ page 17

LT, $\lambda_{\text{dom}} = f(I_F); T_A = 25\text{ °C}$

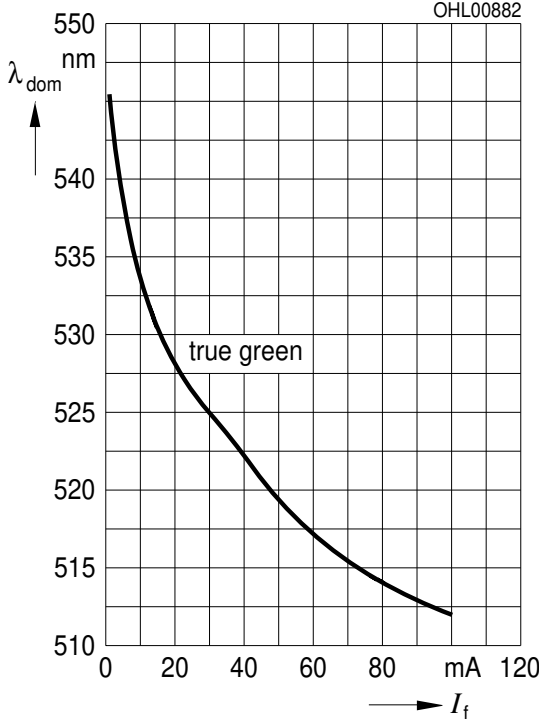

Dominante Wellenlänge²⁾ Seite 17

Dominant Wavelength²⁾ page 17

LV, $\lambda_{\text{dom}} = f(I_F); T_A = 25\text{ °C}$

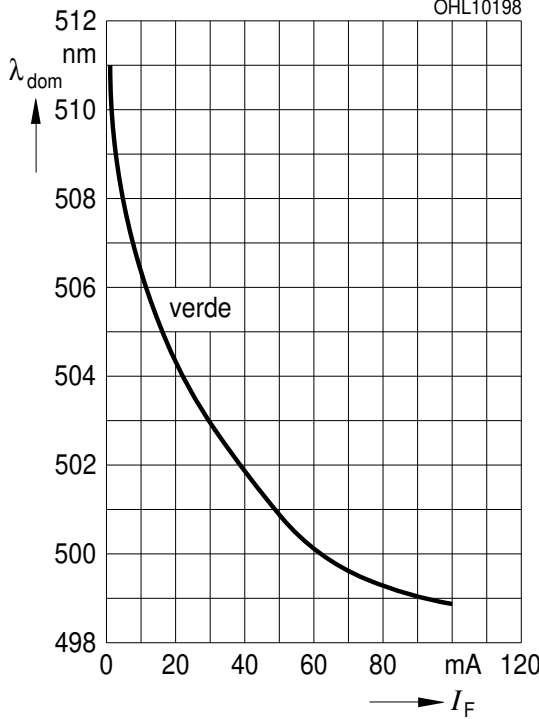

Dominante Wellenlänge²⁾ Seite 17

Dominant Wavelength²⁾ page 17

LB, $\lambda_{\text{dom}} = f(I_F); T_A = 25\text{ °C}$

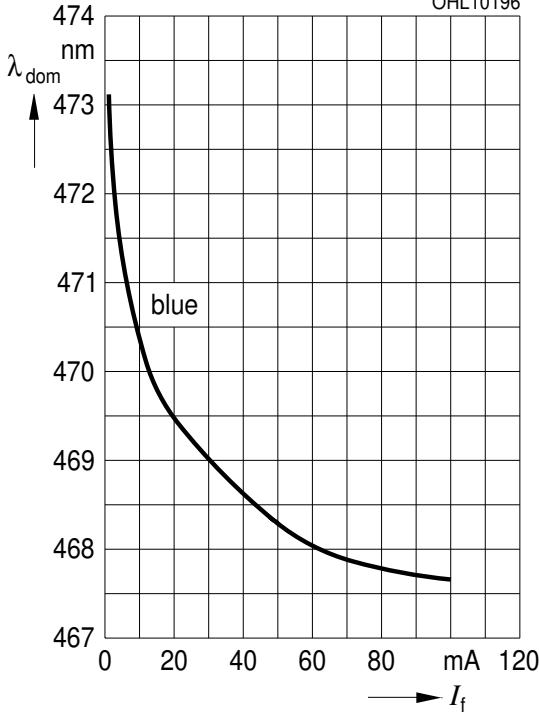

Maximal zulässiger Durchlassstrom
Max. Permissible Forward Current

$I_F = f(T)$

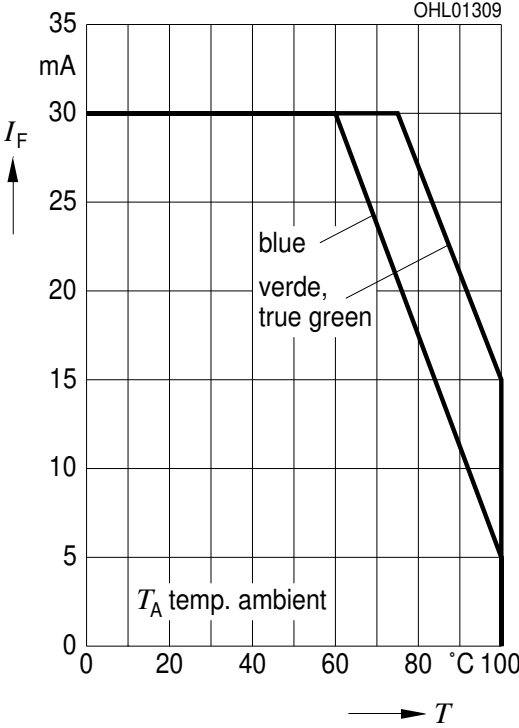

Maximal zulässiger Durchlassstrom
Max. Permissible Forward Current

$I_F = f(T)$

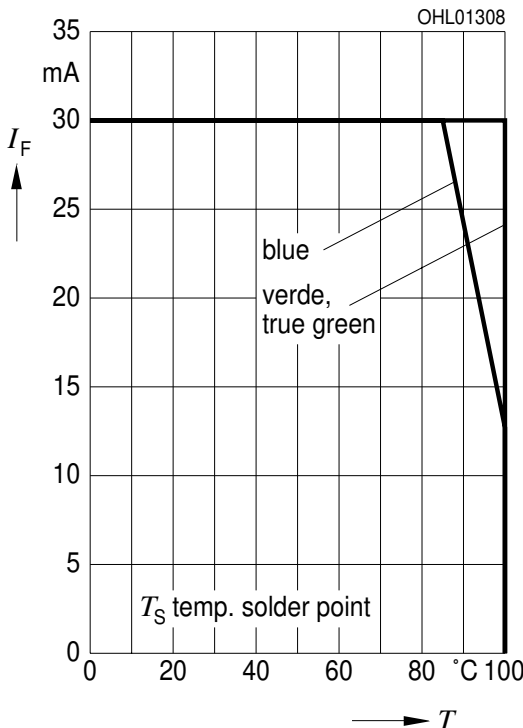

Zulässige Impulsbelastbarkeit $I_F = f(t_p)$
Permissible Pulse Handling Capability
 Duty cycle $D =$ parameter, $T_A = 25\text{ °C}$, **LB**

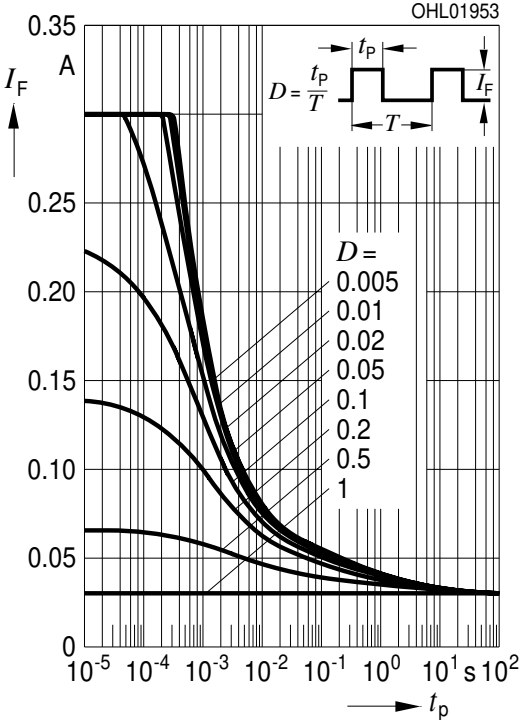

Zulässige Impulsbelastbarkeit $I_F = f(t_p)$
Permissible Pulse Handling Capability
 Duty cycle $D =$ parameter, $T_A = 85\text{ °C}$, **LB**

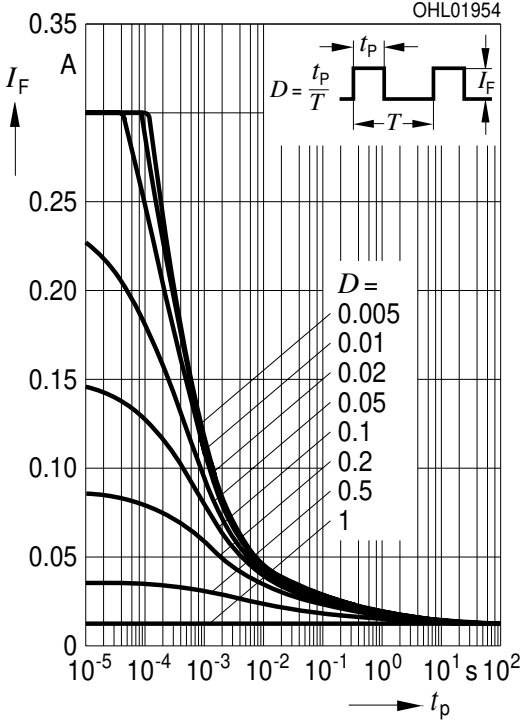

Zulässige Impulsbelastbarkeit $I_F = f(t_p)$
Permissible Pulse Handling Capability
 Duty cycle $D =$ parameter, $T_A = 25\text{ °C}$, **LT / LV**

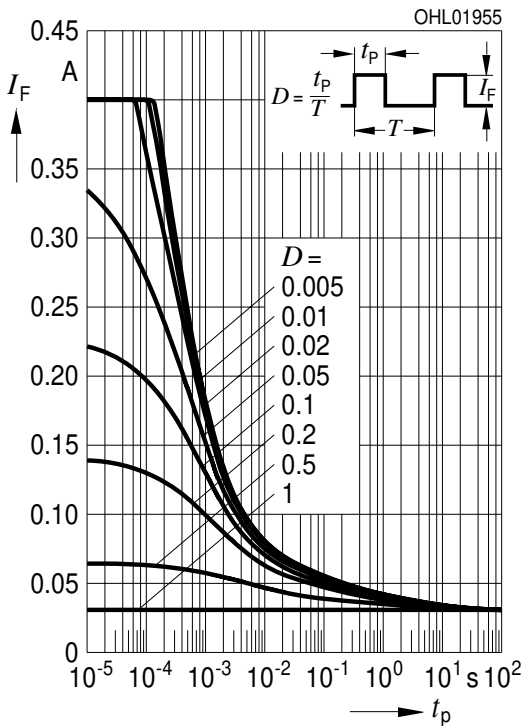

Zulässige Impulsbelastbarkeit $I_F = f(t_p)$
Permissible Pulse Handling Capability
 Duty cycle $D =$ parameter, $T_A = 85\text{ °C}$, **LT / LV**

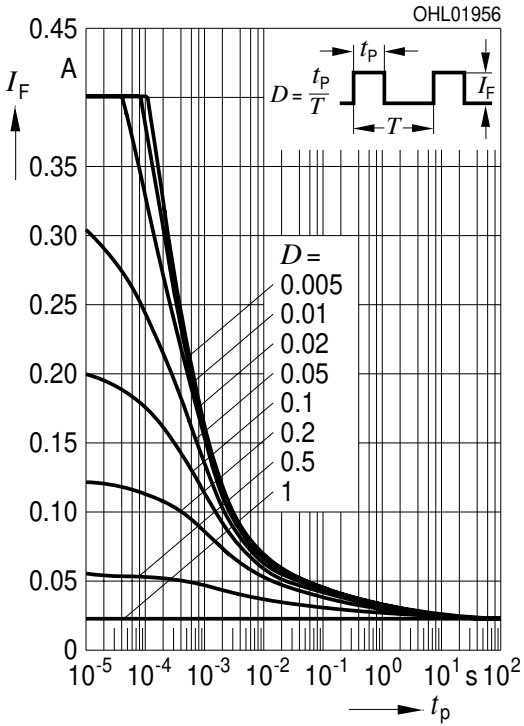

Maßzeichnung⁸⁾ Seite 17
 Package Outlines⁸⁾ page 17

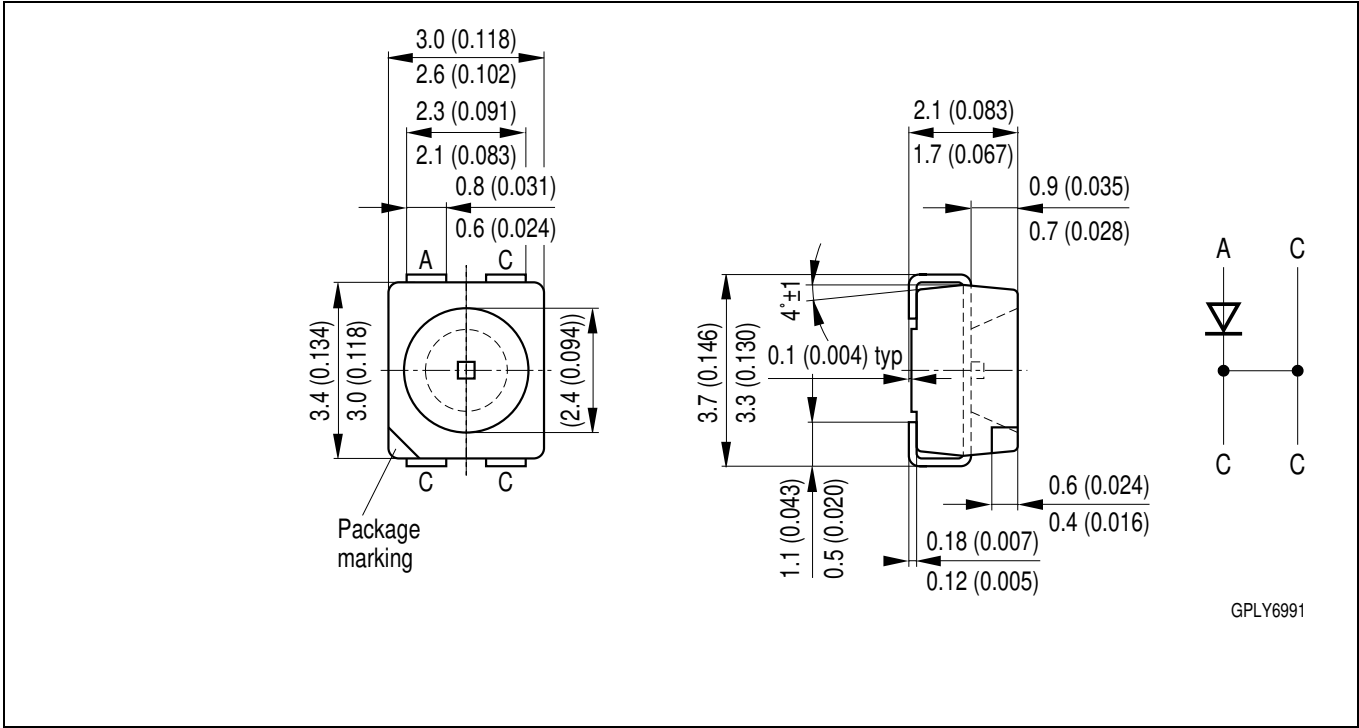

Gewicht / Approx. weight: 35 mg

Gurtung / Polarität und Lage⁸⁾ Seite 17 Verpackungseinheit 2000/Rolle, ø180 mm
 oder 8000/Rolle, ø330 mm

Method of Taping / Polarity and Orientation⁸⁾ page 17 Packing unit 2000/reel, ø180 mm
 or 8000/reel, ø330 mm

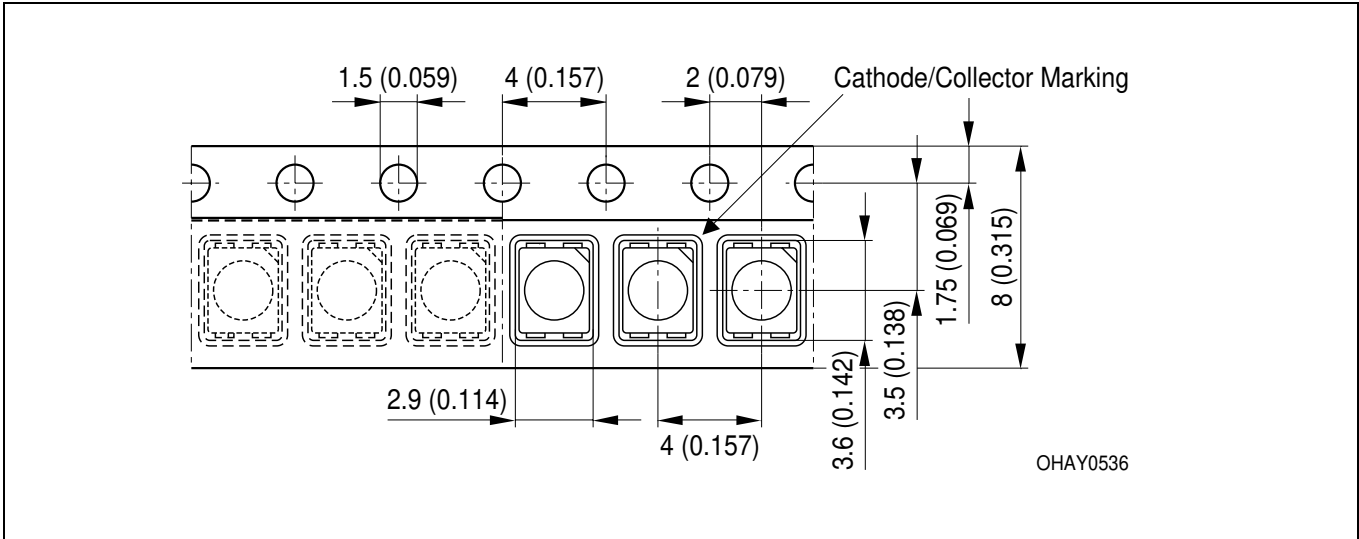

Empfohlenes Lötpaddesign verwendbar für TOPLED® und Power TOPLED®

IR Reflow Löten⁸⁾ Seite 17

Recommended Solder Pad useable for TOPLED® and Power TOPLED®

IR Reflow Soldering⁸⁾ page 17

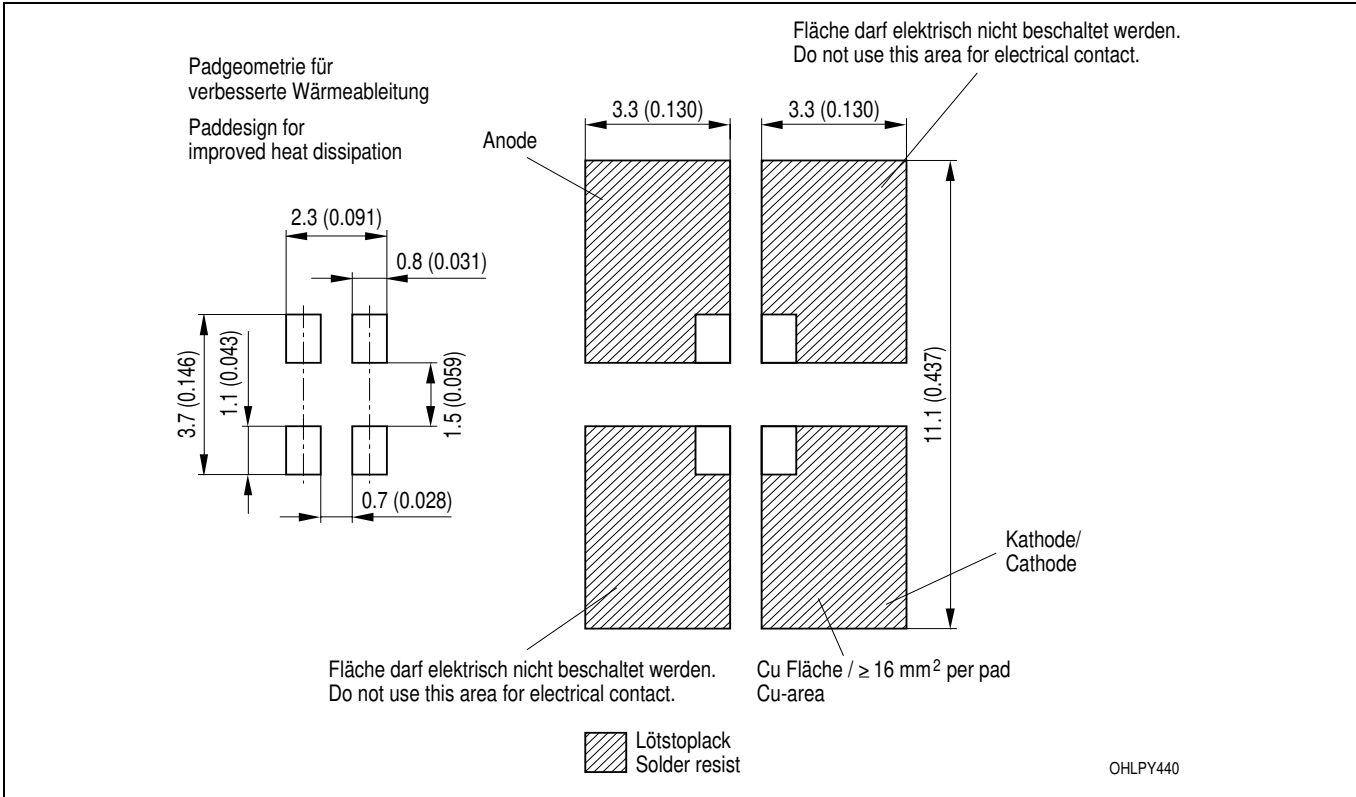

Empfohlenes Lötpaddesign⁸⁾ Seite 17

Recommended Solder Pad⁸⁾ page 17

Wellenlöten (TTW)

TTW Soldering

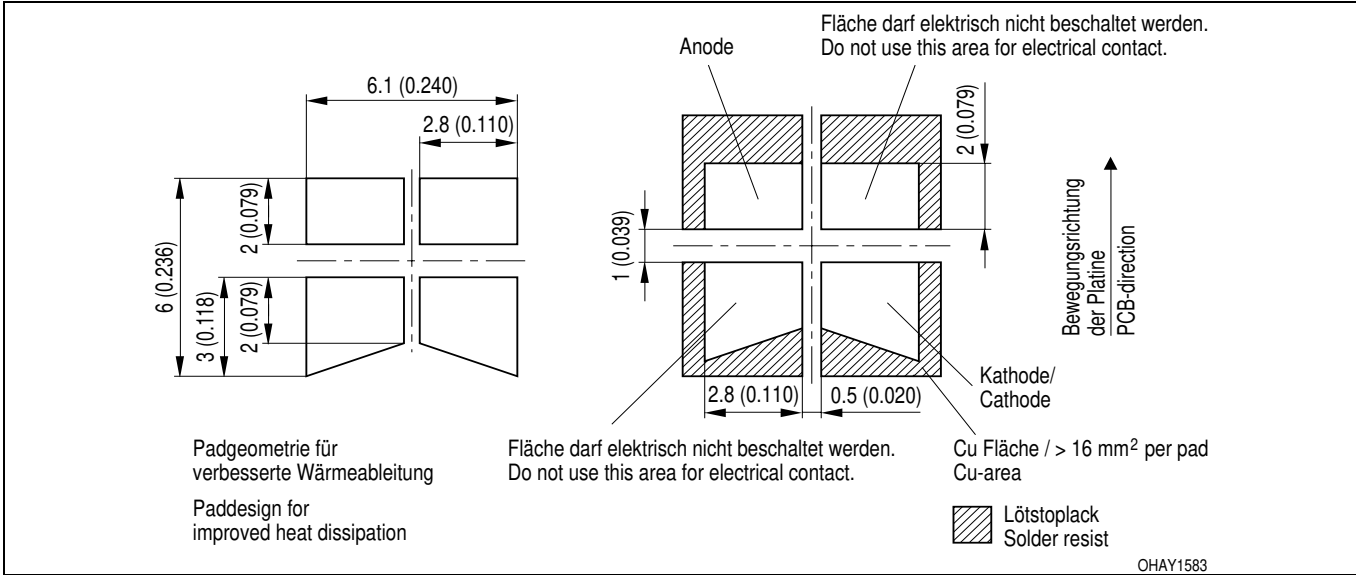

Lötbedingungen
Soldering Conditions

Vorbehandlung nach JEDEC Level 2
Preconditioning acc. to JEDEC Level 2

IR-Reflow Lötprofil
IR Reflow Soldering Profile

(nach IPC 9501)
(acc. to IPC 9501)

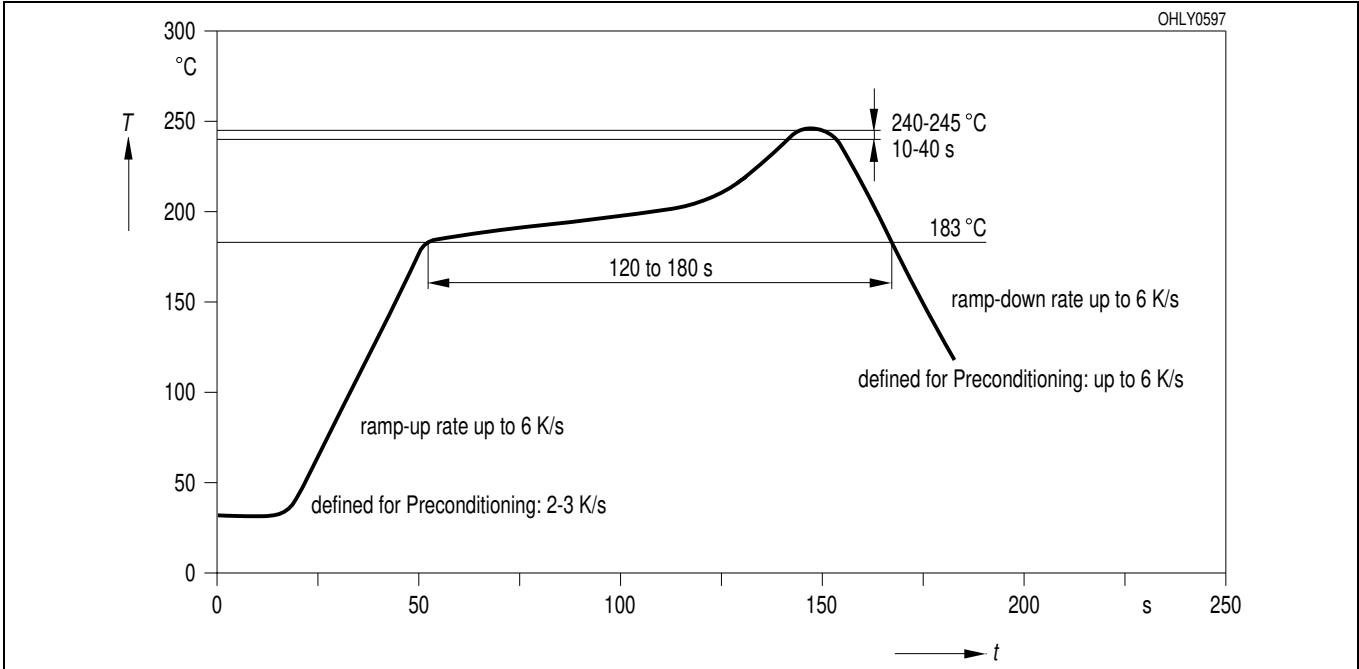

Wellenlöten (TTW)
TTW Soldering

(nach CECC 00802)
(acc. to CECC 00802)

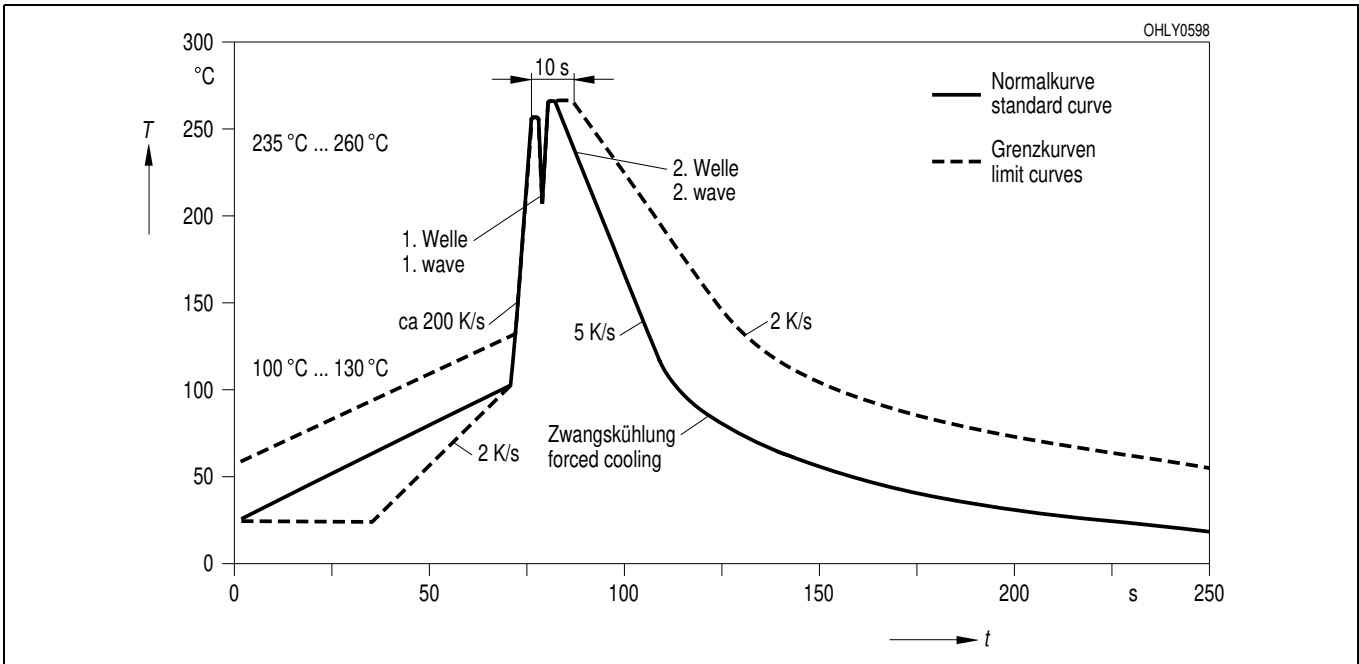

Barcode-Produkt-Etikett (BPL)
Barcode-Product-Label (BPL)

OSRAM Opto Semiconductors

Lx xxxx Bin1: Bin Information Color 1
 Bin2:
 Product Name Bin3:

(6P) BATCH NO: Batch Number
Bar Code

(1T) LOT NO: Lot Number (9D) D/C: Date Code
Bar Code

(X) PROD NO: Product Code (Q)QTY: Product Quantity per Reel (G) GROUP: X - X - X
Bar Code

ML Temp ST
 2 245 C R
 2 260 C T

Additional TEXT
 R077 DEMY
 PACKVAR: Packing Type

Forward Voltage Rank
 Wavelength Rank
 Brightness Rank

OHA02043

Gurtverpackung
Tape and Reel

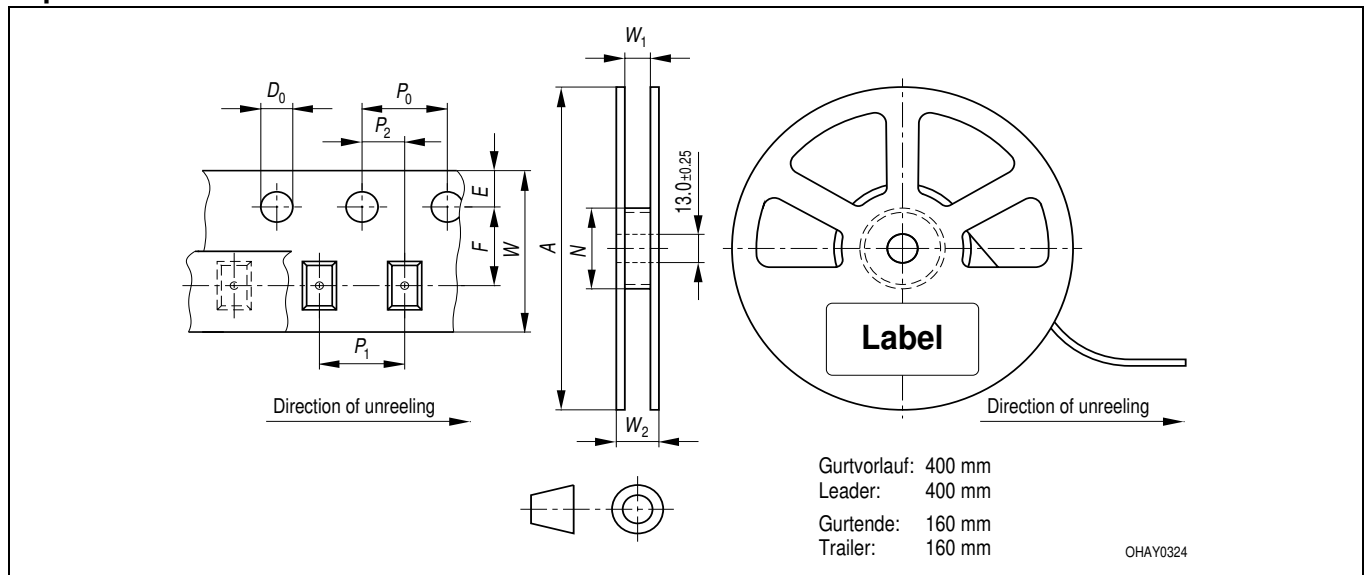

Tape dimensions in mm (inch)

W	P ₀	P ₁	P ₂	D ₀	E	F
8 +0.3 -0.1	4 ± 0.1 (0.157 ± 0.004)	4 ± 0.1 (0.157 ± 0.004)	2 ± 0.05 (0.079 ± 0.002)	1.5 + 0.1 (0.059 + 0.004)	1.75 ± 0.1 (0.069 ± 0.004)	3.5 ± 0.05 (0.138 ± 0.002)

Reel dimensions in mm (inch)

A	W	N _{min}	W ₁	W _{2 max}
180 (7)	8 (0.315)	60 (2.362)	8.4 + 2 (0.331 + 0.079)	14.4 (0.567)
330 (13)	8 (0.315)	60 (2.362)	8.4 + 2 (0.331 + 0.079)	14.4 (0.567)

Trockenverpackung und Materialien
Dry Packing Process and Materials

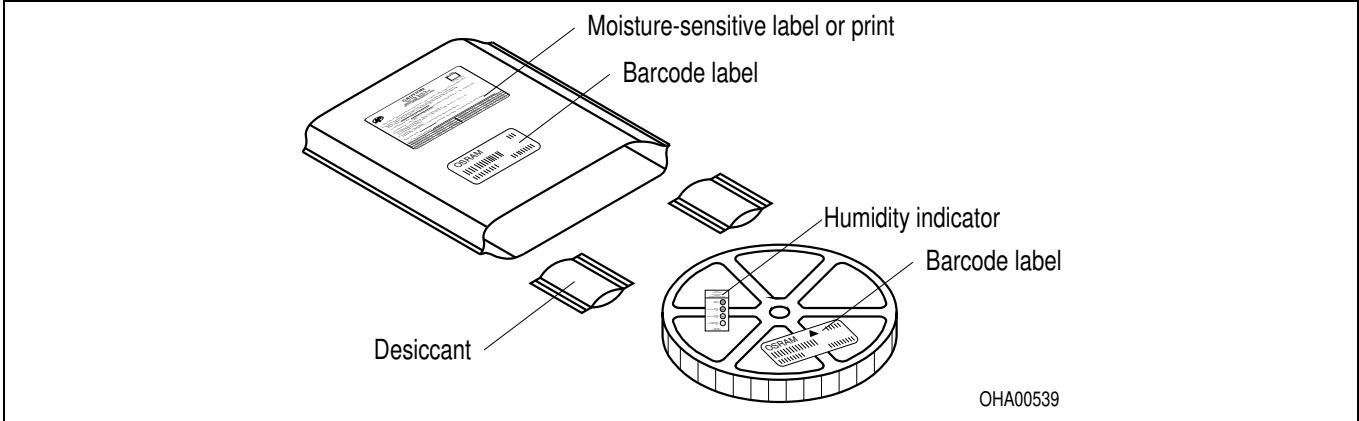

Anm.: Feuchteempfindliche Produkte sind verpackt in einem Trockenbeutel zusammen mit einem Trockenmittel und einer Feuchteindikatorkarte
Bezüglich Trockenverpackung finden Sie weitere Hinweise im Internet und in unserem Short Form Catalog im Kapitel "Gurtung und Verpackung" unter dem Punkt "Trockenverpackung". Hier sind Normenbezüge, unter anderem ein Auszug der JEDEC-Norm, enthalten.

Note: Moisture-sensitive product is packed in a dry bag containing desiccant and a humidity card.
Regarding dry pack you will find further information in the internet and in the Short Form Catalog in chapter "Tape and Reel" under the topic "Dry Pack". Here you will also find the normative references like JEDEC.

Kartonverpackung und Materialien
Transportation Packing and Materials

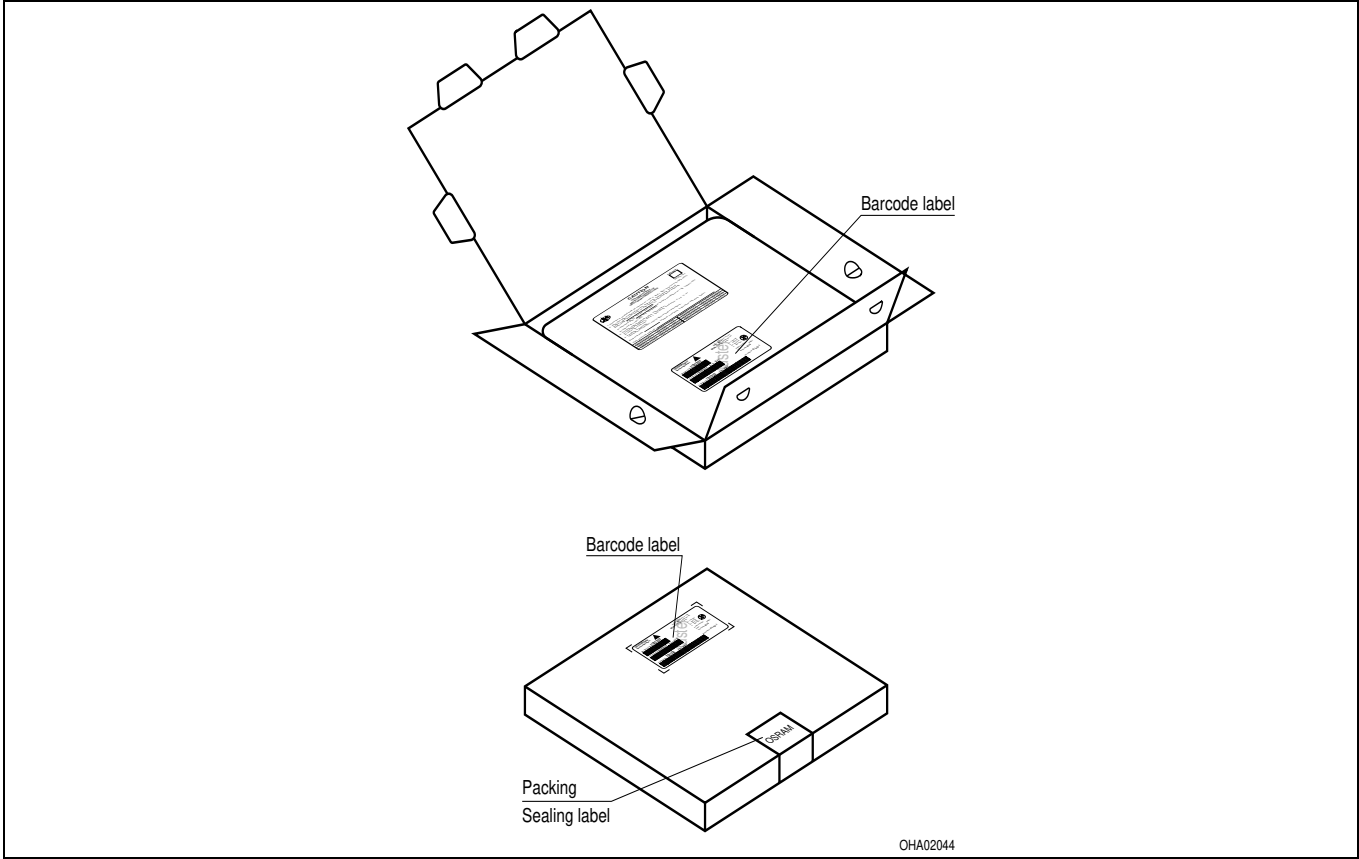

Revision History: 2005-04-05

Previous Version: 2005-03-01

Page	Subjects (major changes since last revision)	Date of change
7	new diagram permissible forward current	2003-06-02
9	new diagrams pulse derating	2003-06-30
1	ESD norm	2003-09-02
3	ambient temperature	2003-09-02
all	new template	2003-09-30
2	ordering code	2005-03-01
all	Discontinuation of non-RoHS compliant product versions	2005-04-05

Attention please!

The information describes the type of component and shall not be considered as assured characteristics. Terms of delivery and rights to change design reserved. Due to technical requirements components may contain dangerous substances. For information on the types in question please contact our Sales Organization. If printed or downloaded, please find the latest version in the Internet.

Packing

Please use the recycling operators known to you. We can also help you – get in touch with your nearest sales office. By agreement we will take packing material back, if it is sorted. You must bear the costs of transport. For packing material that is returned to us unsorted or which we are not obliged to accept, we shall have to invoice you for any costs incurred.

Components used in life-support devices or systems must be expressly authorized for such purpose! Critical components^{9) page 17} may only be used in life-support devices or systems^{10) page 17} with the express written approval of OSRAM OS.

Fußnoten:

- 1) Helligkeitswerte werden mit einer Stromeinprägedauer von 25 ms und einer Genauigkeit von $\pm 11\%$ ermittelt.
- 2) Wegen der besonderen Prozessbedingungen bei der Herstellung von LED können typische oder abgeleitete technische Parameter nur aufgrund statistischer Werte wiedergegeben werden. Diese stimmen nicht notwendigerweise mit den Werten jedes einzelnen Produktes überein, dessen Werte sich von typischen und abgeleiteten Werten oder typischen Kennlinien unterscheiden können. Falls erforderlich, z.B. aufgrund technischer Verbesserungen, werden diese typischen Werte ohne weitere Ankündigung geändert.
- 3) Die LED kann kurzzeitig in Sperrichtung betrieben werden.
- 4) R_{thJA} ergibt sich bei Montage auf PC-Board FR 4 (Padgröße $\geq 16 \text{ mm}^2$ je Pad)
- 5) Wellenlängen werden mit einer Stromeinprägedauer von 25 ms und einer Genauigkeit von $\pm 1 \text{ nm}$ ermittelt.
- 6) Spannungswerte werden mit einer Stromeinprägedauer von 1 ms und einer Genauigkeit von $\pm 0,1 \text{ V}$ ermittelt.
- 7) Im gestrichelten Bereich der Kennlinien muss mit erhöhten Helligkeitsunterschieden zwischen Leuchtdioden innerhalb einer Verpackungseinheit gerechnet werden
- 8) Maße werden wie folgt angegeben: mm (inch)
- 9) Ein kritisches Bauteil ist ein Bauteil, das in lebenserhaltenden Apparaten oder Systemen eingesetzt wird und dessen Defekt voraussichtlich zu einer Fehlfunktion dieses lebenserhaltenden Apparates oder Systems führen wird oder die Sicherheit oder Effektivität dieses Apparates oder Systems beeinträchtigt.
- 10) Lebenserhaltende Apparate oder Systeme sind für
 - (a) die Implantierung in den menschlichen Körper oder
 - (b) für die Lebenserhaltung bestimmt.
 Falls sie versagen, kann davon ausgegangen werden, dass die Gesundheit und das Leben des Patienten in Gefahr ist.

Remarks:

- 1) Brightness groups are tested at a current pulse duration of 25 ms and a tolerance of $\pm 11\%$.
- 2) Due to the special conditions of the manufacturing processes of LED, the typical data or calculated correlations of technical parameters can only reflect statistical figures. These do not necessarily correspond to the actual parameters of each single product, which could differ from the typical data and calculated correlations or the typical characteristic line. If requested, e.g. because of technical improvements, these typ. data will be changed without any further notice.
- 3) Driving the LED in reverse direction is suitable for short term application.
- 4) R_{thJA} results from mounting on PC board FR 4 (pad size $\geq 16 \text{ mm}^2$ per pad)
- 5) Wavelengths are tested at a current pulse duration of 25 ms and a tolerance of $\pm 1 \text{ nm}$.
- 6) Forward voltages are tested at a current pulse duration of 1 ms and a tolerance of $\pm 0.1 \text{ V}$.
- 7) In the range where the line of the graph is broken, you must expect higher brightness differences between single LEDs within one packing unit.
- 8) Dimensions are specified as follows: mm (inch).
- 9) A critical component is a component used in a life-support device or system whose failure can reasonably be expected to cause the failure of that life-support device or system, or to affect its safety or the effectiveness of that device or system.
- 10) Life support devices or systems are intended
 - (a) to be implanted in the human body,
 - or
 - (b) to support and/or maintain and sustain human life.
 If they fail, it is reasonable to assume that the health and the life of the user may be endangered.