



Chipsmall Limited consists of a professional team with an average of over 10 year of expertise in the distribution of electronic components. Based in Hongkong, we have already established firm and mutual-benefit business relationships with customers from,Europe,America and south Asia,supplying obsolete and hard-to-find components to meet their specific needs.

With the principle of "Quality Parts,Customers Priority,Honest Operation,and Considerate Service",our business mainly focus on the distribution of electronic components. Line cards we deal with include Microchip,ALPS,ROHM,Xilinx,Pulse,ON,Everlight and Freescale. Main products comprise IC,Modules,Potentiometer,IC Socket,Relay,Connector.Our parts cover such applications as commercial,industrial, and automotives areas.

We are looking forward to setting up business relationship with you and hope to provide you with the best service and solution. Let us make a better world for our industry!



## Contact us

Tel: +86-755-8981 8866 Fax: +86-755-8427 6832

Email & Skype: info@chipsmall.com Web: www.chipsmall.com

Address: A1208, Overseas Decoration Building, #122 Zhenhua RD., Futian, Shenzhen, China



## FEATURES

- Digital Selection of 0V,  $V_{CC}$ , 12V or Hi-Z
- Output Current Capability: 120mA
- Internal Current Limiting and Thermal Shutdown
- Automatic Switching from 3.3V to 5V
- Powered from Unregulated 13V to 20V Supply
- Logic Compatible with Standard PCMCIA Controllers
- Output Capacitors: 1 $\mu$ F
- Quiescent Current in Hi-Z or 0V Mode: 60 $\mu$ A
- Independent VPP Valid Status Feedback Signals
- No VPP Overshoot

## APPLICATIONS

- Notebook Computers
- Palmtop Computers
- Pen-Based Computers
- Handi-Terminals
- Bar-Code Readers
- Flash Memory Programming

## DESCRIPTION

The LT<sup>®</sup>1313 is a member of Linear Technology Corporation's PCMCIA driver/regulator family. It provides 0V, 3.3V, 5V, 12V and Hi-Z regulated power to the VPP pins of two PCMCIA card slots from a single unregulated 13V to 20V supply. When used in conjunction with a PC Card Interface Controller, the LT1313 forms a complete minimum component-count interface for palmtop, pen-based and notebook computers. The two VPP output voltages are independently selected by four logic compatible digital inputs which interface directly with industry standard PC Card Interface Controllers.

Automatic 3.3V to 5V switching is provided by two independent comparators which continuously monitor each PC card  $V_{CC}$  supply voltage and automatically adjust the VPP output to match the associated  $V_{CC}$  pin voltage when the VPP =  $V_{CC}$  mode is selected.

Two open-collector VPP  $\overline{\text{VALID}}$  outputs are provided to indicate when the VPP outputs are in regulation at 12V.

The LT1313 is available in 16-pin SO packaging.

 LTC and LT are registered trademarks of Linear Technology Corporation.

## TYPICAL APPLICATION

Typical PCMCIA Dual Slot VPP Driver

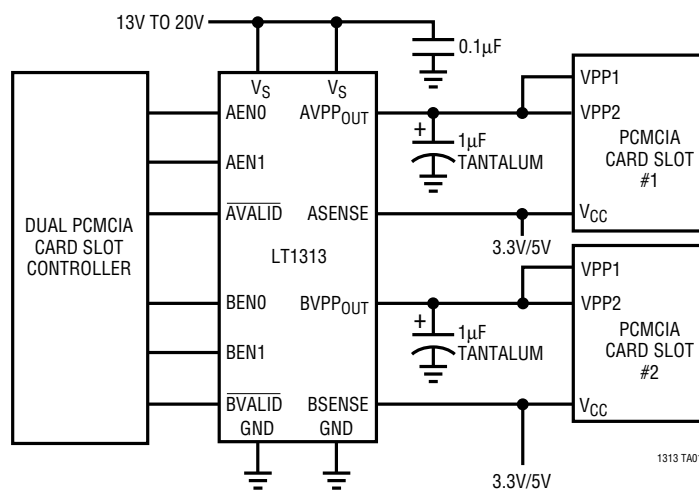

Linear Technology PCMCIA Product Family

DEVICE	DESCRIPTION	PACKAGE
LT1312	SINGLE PCMCIA VPP DRIVER/REGULATOR	8-PIN SO
LT1313	DUAL PCMCIA VPP DRIVER/REGULATOR	16-PIN SO*
LTC <sup>®</sup> 1314	SINGLE PCMCIA SWITCH MATRIX	14-PIN SO
LTC1315	DUAL PCMCIA SWITCH MATRIX	24-PIN SSOP
LTC1470	PROTECTED $V_{CC}$ 5V/3.3V SWITCH MATRIX	8-PIN SO
LTC1472	PROTECTED $V_{CC}$ AND VPP SWITCH MATRIX	16-PIN SO*

\*NARROW BODY

**ABSOLUTE MAXIMUM RATINGS**

Supply Voltage ..... 22V  
 Digital Input Voltage ..... 7V to (GND – 0.3V)  
 Sense Input Voltage ..... 7V to (GND – 0.3V)  
 VALID Output Voltage ..... 15V to (GND – 0.3V)  
 Output Short-Circuit Duration ..... Indefinite  
 Operating Temperature ..... 0°C to 70°C  
 Junction Temperature ..... 0°C to 125°C  
 Storage Temperature Range ..... –65°C to 150°C  
 Lead Temperature (Soldering, 10 sec) ..... 300°C

**PACKAGE/ORDER INFORMATION**

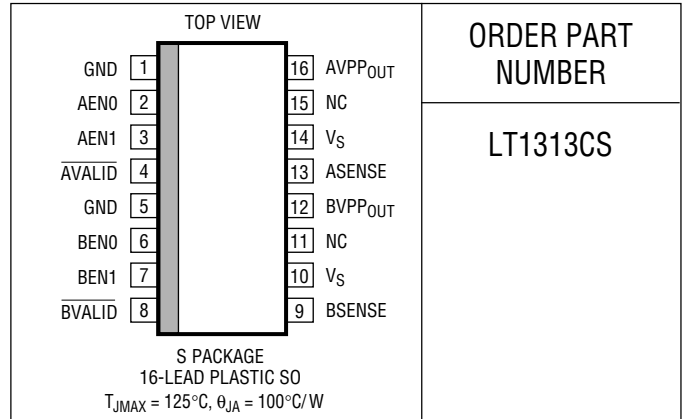

ORDER PART NUMBER

LT1313CS

Consult factory for Industrial and Military grade parts.

**ELECTRICAL CHARACTERISTICS**  $V_S = 13V$  to  $20V$ ,  $T_A = 25^\circ C$  (Note 1), unless otherwise noted.

SYMBOL	PARAMETER	CONDITIONS	MIN	TYP	MAX	UNITS	
VPP <sub>OUT</sub>	Output Voltage	Program to 12V, I <sub>OUT</sub> ≤ 120mA (Note 2)	●	11.52	12.00	12.48	V
		Program to 5V, I <sub>OUT</sub> ≤ 30mA (Note 2)	●	4.75	5.00	5.25	V
		Program to 3.3V, I <sub>OUT</sub> ≤ 30mA (Note 2)	●	3.135	3.30	3.465	V
		Program to 0V, I <sub>OUT</sub> = –300μA			0.42	0.60	V
I <sub>LKG</sub>	Output Leakage	Program to Hi-Z, 0V ≤ VPP <sub>OUT</sub> ≤ 12V	●	–10	10	μA	
I <sub>S</sub>	Supply Current	Both Channels Programmed to 0V	●	60	100	μA	
		Both Channels Programmed to Hi-Z	●	60	100	μA	
		One Channel Programmed to 12V, No Load (Note 3)	●	260	400	μA	
		One Channel Programmed to 5V, No Load (Note 3)	●	105	150	μA	
		One Channel Programmed to 3.3V, No Load (Note 3)	●	85	120	μA	
		One Channel Programmed to 12V, I <sub>OUT</sub> = 120mA (Note 3)	●	126	132	mA	
		One Channel Programmed to 5V, I <sub>OUT</sub> = 30mA (Note 3)	●	31	33	mA	
		One Channel Programmed to 3.3V, I <sub>OUT</sub> = 30mA (Note 3)	●	31	33	mA	
I <sub>LIM</sub>	Current Limit	Program to 3.3V, 5V or 12V (Note 3)		330	500	mA	
V <sub>ENH</sub>	Enable Input High Voltage		●	2.4		V	
V <sub>ENL</sub>	Enable Input Low Voltage		●		0.4	V	
I <sub>ENH</sub>	Enable Input High Current	2.4V ≤ V <sub>IN</sub> ≤ 5.5V		20	50	μA	
I <sub>ENL</sub>	Enable Input Low Current	0V ≤ V <sub>IN</sub> ≤ 0.4V		0.01	1	μA	
V <sub>SEN5</sub>	V <sub>CC</sub> Sense Threshold	VPP <sub>OUT</sub> = 3.3V to 5V (Note 4)	●	3.60	4.05	4.50	V
V <sub>SEN3</sub>	V <sub>CC</sub> Sense Threshold	VPP <sub>OUT</sub> = 5V to 3.3V (Note 4)	●	3.60	4.00	4.50	V
I <sub>SEN</sub>	V <sub>CC</sub> Sense Input Current	V <sub>SENSE</sub> = 5V		38	60	μA	
		V <sub>SENSE</sub> = 3.3V		18	30	μA	
V <sub>VALID TH</sub>	VPP <sub>VALID</sub> Threshold Voltage	Program to 12V, (Note 5)	●	10.5	11	11.5	V
I <sub>VALID</sub>	VPP <sub>VALID</sub> Output Drive Current	Program to 12V, V <sub>VALID</sub> = 0.4V, (Note 5)		1	3.3	mA	
	VPP <sub>VALID</sub> Output Leakage Current	Program to 0V, V <sub>VALID</sub> = 12V, (Note 5)		0.1	10	μA	

The ● denotes the specifications which apply over the full operating temperature range.

**Note 1:** Both V<sub>S</sub> pins (10, 14) must be connected together, and both ground pins (1, 5) must be connected together.

**Note 2:** For junction temperatures greater than 110°C, a minimum load of 1mA is recommended.

**Note 3:** The other channel is programmed to the 0V mode (XENO = XEN1 = 0V) during this test.

**Note 4:** The V<sub>CC</sub> sense threshold voltage tests are performed independently.

**Note 5:** The VPP<sub>VALID</sub> tests are performed independently.

# TYPICAL PERFORMANCE CHARACTERISTICS

**Quiescent Current (0V or Hi-Z Mode)**

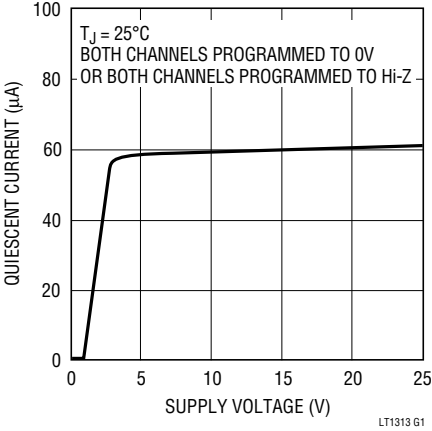

**Quiescent Current (12V Mode)**

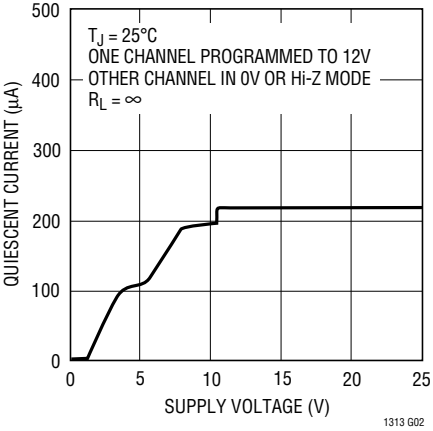

**Quiescent Current (3.3V/5V Mode)**

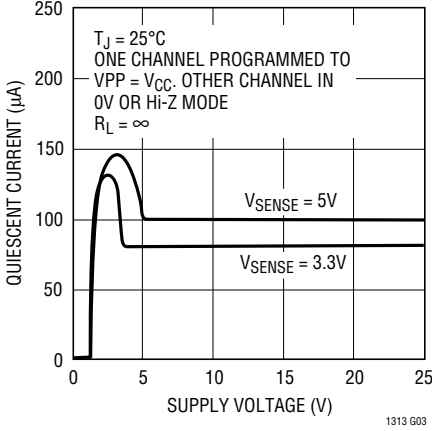

**Ground Pin Current (12V Mode)**

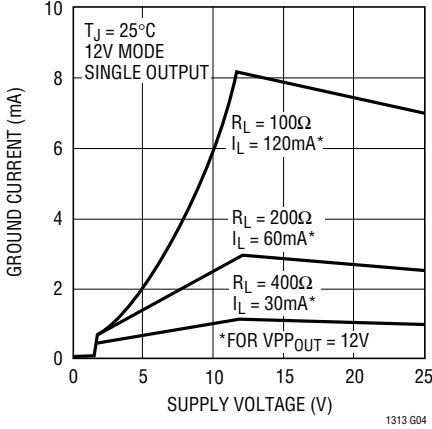

**Ground Pin Current (5V Mode)**

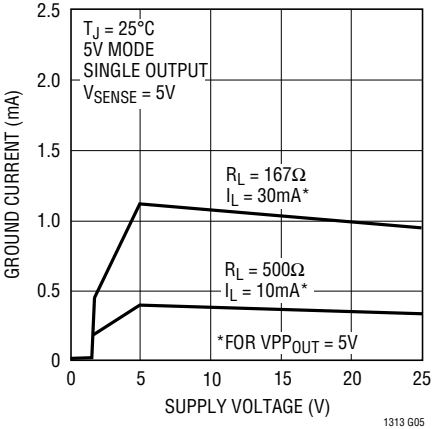

**Ground Pin Current (3.3V Mode)**

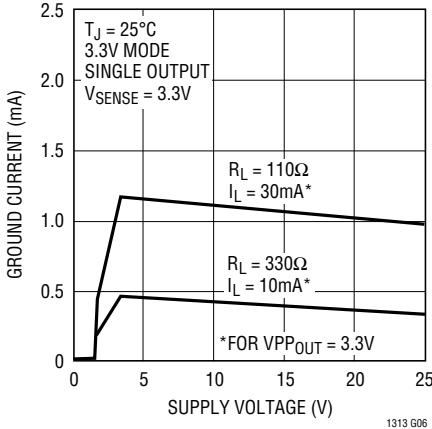

**Ground Pin Current**

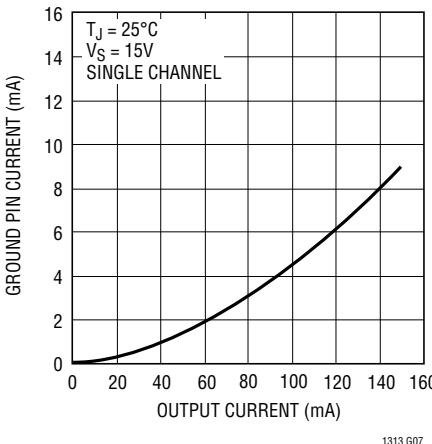

**Current Limit**

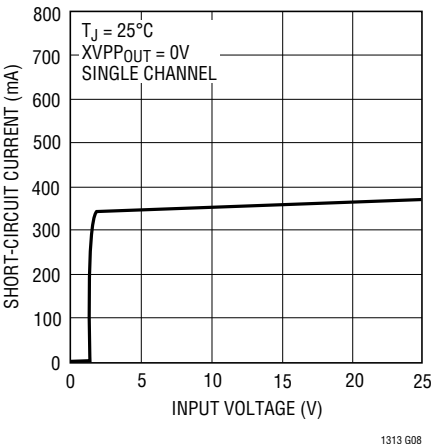

**Current Limit**

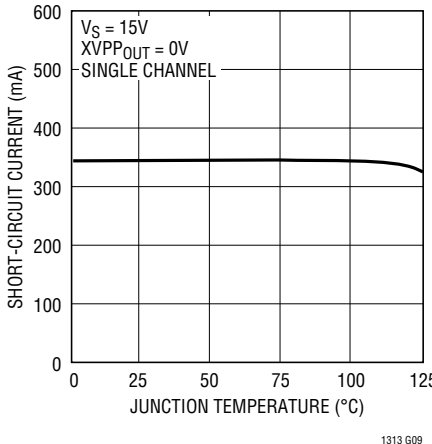

# TYPICAL PERFORMANCE CHARACTERISTICS

**Enable Input Threshold Voltage**

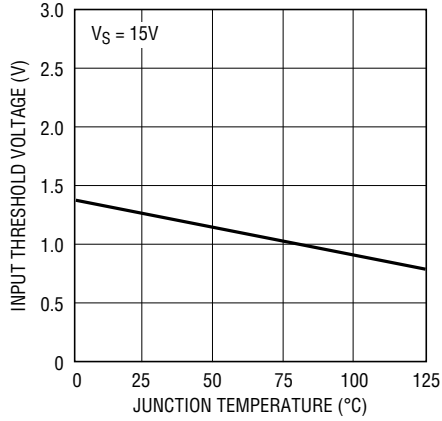

1313 G10

**Enable Input Current**

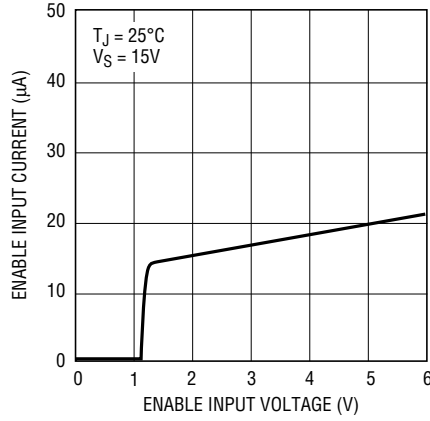

1313 G11

**V<sub>CC</sub> Sense Threshold Voltage**

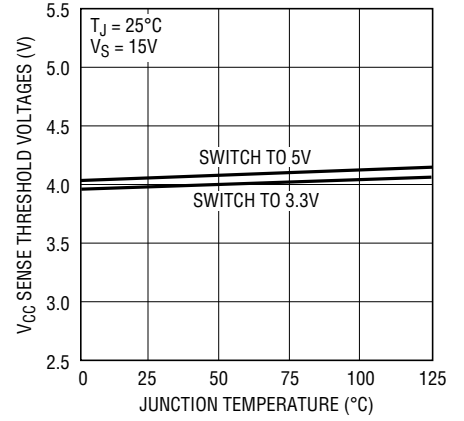

1313 G12

**V<sub>CC</sub> Sense Input Current**

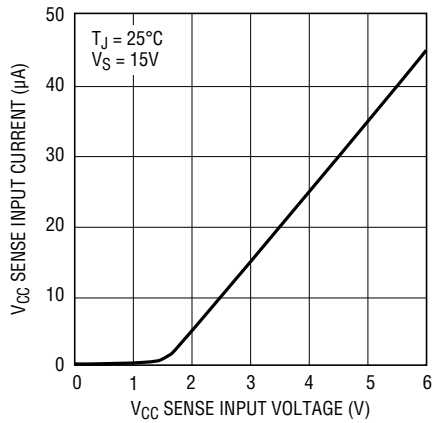

1313 G13

**VALID Output Voltage**

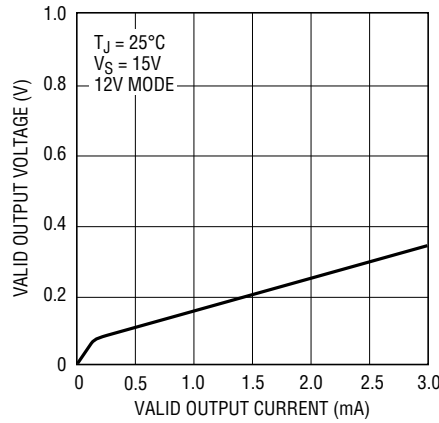

1313 G14

**Ripple Rejection (12V)**

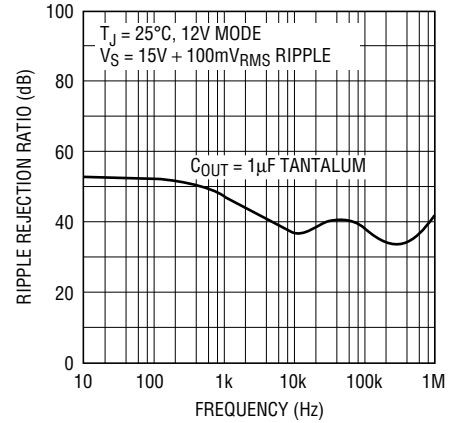

1313 G15

**12V Turn-On Waveform**

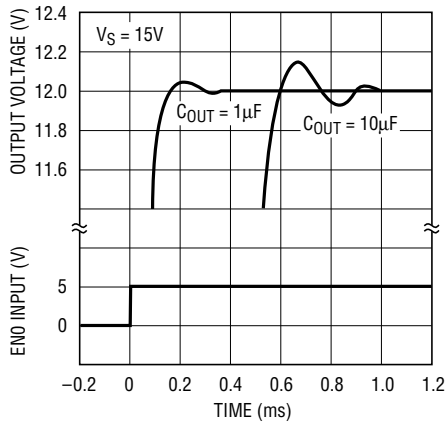

1313 G16

**Line Transient Response (12V)**

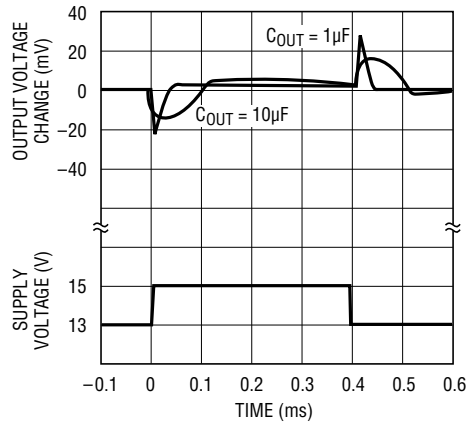

1313 G17

**Load Transient Response (12V)**

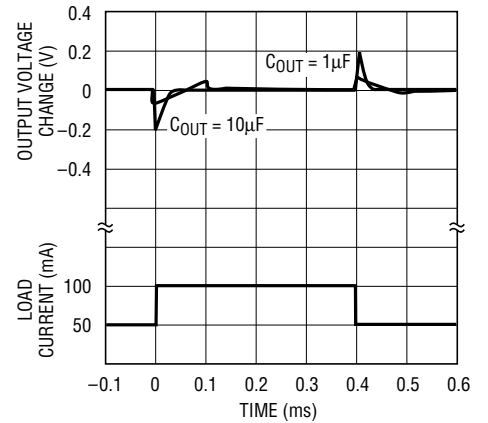

1313 G18

## PIN FUNCTIONS

**Supply Pins:** Power is supplied to the device through the two supply pins *which must be connected together at all times*. The supply pins should be bypassed to ground if the device is more than six inches away from the main supply capacitor. A bypass capacitor in the range of 0.1 $\mu$ F to 1 $\mu$ F is sufficient. The supply voltage to the LT1313 can be loosely regulated between 13V and 20V.

**VPP<sub>OUT</sub> Pins:** Each regulated output supplies power to the two PCMCIA card VPP pins which are typically tied together at the socket. Each VPP<sub>OUT</sub> output is current limited to approximately 330mA. Thermal shutdown provides a second level of protection. A 1 $\mu$ F to 10 $\mu$ F tantalum output capacitor is recommended.

**Input Enable Pins:** The four digital input pins are high impedance inputs with approximately 20 $\mu$ A input current at 2.4V. The input thresholds are compatible with CMOS controllers and can be driven from either 5V or 3.3V CMOS logic. ESD protection diodes limit input excursions to 0.6V below ground.

**VALID Output Pins:** These pins are open-collector NPN outputs which are driven low when the corresponding VPP<sub>OUT</sub> pin is in regulation, i.e., when it is above 11V. Two external 51k pull-up resistors are connected between these outputs and the same 5V or 3.3V logic supply powering the PCMCIA compatible control logic.

**V<sub>CC</sub> Sense Pins:** Two independent comparators and 4V references automatically switch the VPP<sub>OUT</sub> outputs from 5V to 3.3V depending upon the voltage sensed at the corresponding PCMCIA card socket V<sub>CC</sub> pin. The input current for these pins is approximately 30 $\mu$ A. For 5V only operation, connect the Sense pins directly to ground. An ESD protection diode limits the input voltage to 0.6V below ground.

**Ground Pins:** *The two ground pins must be connected together at all times.*

## BLOCK DIAGRAM (One Channel)

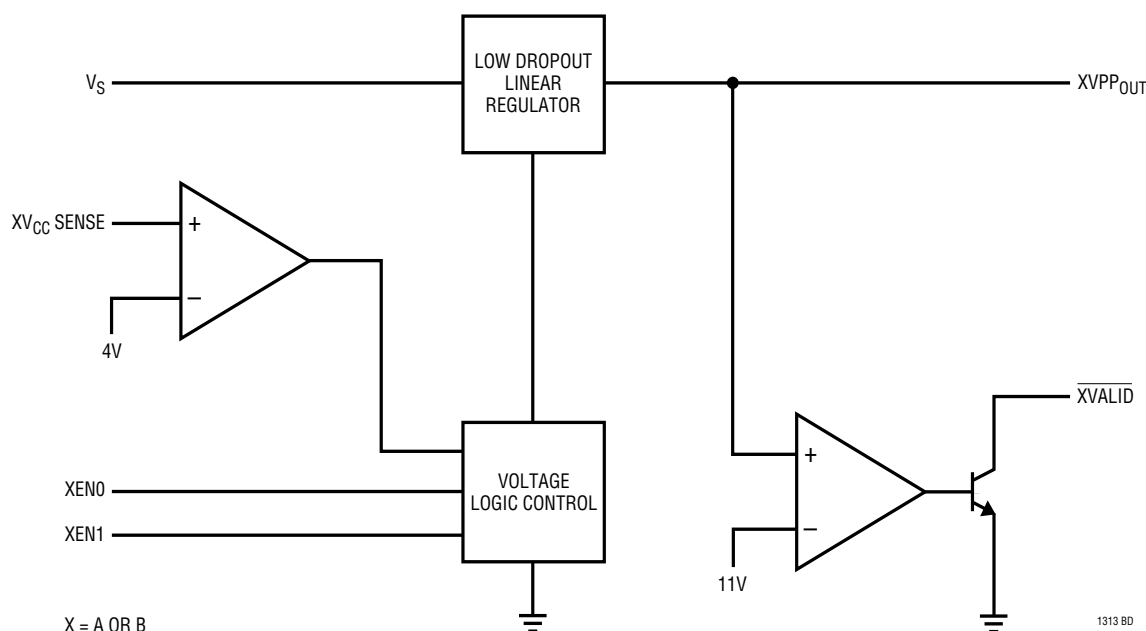

## OPERATION

The LT1313 is two programmable output voltage, low-dropout linear regulators designed specifically for PCMCIA VPP drive applications. Input power is typically obtained from a loosely regulated input supply between 13V and 20V. The LT1313 consists of the following blocks:

**Two Low Dropout Voltage Linear Regulators:** The heart of the LT1313 is two PNP-based low-dropout voltage regulators which drop the unregulated supply voltage from 13V to 20V down to 12V, 5V, 3.3V, 0V or Hi-Z depending upon the state of the four Enable inputs and the two  $V_{CC}$  Sense inputs. The regulators have built-in current limiting and thermal shutdown to protect the device, the loads, and the sockets against inadvertent short circuiting to ground.

**Voltage Control Logic:** The two  $VPP_{OUT}$  outputs have five possible output modes: 0V, 3.3V, 5V, 12V and Hi-Z. These five modes are selected by the four Enable inputs and the two  $V_{CC}$  Sense inputs as described by the Truth Table.

**$V_{CC}$  Sense Comparators:** When the  $V_{CC}$  mode is selected, the LT1313 automatically adjusts each regulated VPP output voltage to 3.3V or 5V depending upon the voltage present

at the corresponding PC card  $V_{CC}$  supply pin. The threshold voltage for these comparators is set at 4V and there is approximately 50mV of hysteresis provided to ensure clean switching between 3.3V and 5V.

**VPP VALID Comparator:** Two voltage comparators monitor each output voltage when the 12V mode is selected and are driven low when the output is in regulation above 11V. These two outputs function separately.

**LT1313 Truth Table**

AEN0	AEN1	ASENSE	AVPP <sub>OUT</sub>	AVALID
0	0	X	0V	1
1	0	X	12V	0
0	1	3.0V to 3.6V	3.3V	1
0	1	4.5V to 5.5V	5V	1
1	1	X	Hi-Z	1

X = Don't Care

BEN0	BEN1	BSENSE	BVPP <sub>OUT</sub>	BVALID
0	0	X	0V	1
1	0	X	12V	0
0	1	3.0V to 3.6V	3.3V	1
0	1	4.5V to 5.5V	5V	1
1	1	X	Hi-Z	1

Note: Each channel is independently controlled.

## APPLICATIONS INFORMATION

The LT1313 is two voltage programmable linear regulators designed specifically for PCMCIA VPP driver applications. The device operates with very low quiescent current (60 $\mu$ A) in the 0V and Hi-Z modes of operation. In the Hi-Z mode, the output leakage current falls to 1 $\mu$ A. In addition to the low quiescent currents, the LT1313 incorporates several protection features which make it ideal for PCMCIA applications. The LT1313 has built-in current limiting (330mA) and thermal shutdown to protect the device and the socket VPP pins against inadvertent short-circuit conditions.

### Output Capacitance

The LT1313 is designed to be stable with a wide range of output capacitors. The minimum recommended value is a 1 $\mu$ F with an ESR of 3 $\Omega$  or less. The capacitor is connected directly between the output pin and ground. For applications where space is very limited, capacitors as low as 0.33 $\mu$ F can

be used. Extremely low ESR ceramic capacitors with values less than 1 $\mu$ F must have a 2 $\Omega$  resistor added in series with the output capacitor.

### Transient and Switching Performance

The LT1313 is designed to produce minimal overshoot with capacitors in the range of 1 $\mu$ F to 10 $\mu$ F. Larger capacitor values can be used with a slowing of rise and fall times.

The positive output slew rate is determined by the 330mA current limit and the output capacitor. The rise time for a 0V to 12V transition is approximately 40 $\mu$ s and the rise time for a 10 $\mu$ F capacitor is roughly 400 $\mu$ s (see the Transient Response curves in the Typical Performance Characteristics section).

## APPLICATIONS INFORMATION

The fall time from 12V to 0V is set by the output capacitor and an internal pull-down current source which sinks about 30mA. This source will fully discharge a 1µF capacitor in less than 1ms.

### Thermal Considerations

Power dissipated by the device is the sum of two components: output current multiplied by the input-output differential voltage:  $I_{OUT} \times (V_{IN} - V_{OUT})$ , and ground pin current multiplied by supply voltage:  $(I_{GND} \times V_{IN})$ .

The ground pin current can be found by examining the Ground Pin Current curves in the Typical Performance Characteristics section.

Heat sinking, for surface mounted devices, is accomplished by using the heat spreading capabilities of the PC board and its copper traces.

The junction temperature of the LT1313 must be limited to 125°C to ensure proper operation. Use Table 1, in conjunction with the typical performance graphs, to calculate the power dissipation and die temperature for a particular application and ensure that the die temperature does not exceed 125°C under any operating conditions.

**Table 1. 16-Pin SO Package\***

COPPER AREA		BOARD AREA	THERMAL RESISTANCE (JUNCTION-TO-AMBIENT)
TOPSIDE	BACKSIDE		
2500 sq mm	2500 sq mm	2500 sq mm	120°C/W
1000 sq mm	2500 sq mm	2500 sq mm	120°C/W
225 sq mm	2500 sq mm	2500 sq mm	125°C/W
1000 sq mm	1000 sq mm	1000 sq mm	131°C/W

\* Device is mounted on topside.

### Calculating Junction Temperature

Example: given an output voltage of 12V, an input supply voltage of 14V, and an output current of 100mA (one VPP output), and a maximum ambient temperature of 50°C, what will the maximum junction temperature be?

Power dissipated by the device will be equal to:

$$I_{OUT} \times (V_S - V_{PP_{OUT}}) + (I_{GND} \times V_{IN})$$

where,

$$I_{OUT} = 100\text{mA}$$

$$V_{IN} = 14\text{V}$$

$$I_{GND} \text{ at } (I_{OUT} = 100\text{mA}, V_{IN} = 14\text{V}) = 5\text{mA}$$

so,

$$P_D = 100\text{mA} \times (14\text{V} - 12\text{V}) + (5\text{mA} \times 15\text{V}) = 0.275\text{W}$$

Using Table 1, the thermal resistance will be in the range of 120°C/W to 131°C/W depending upon the copper area. So the junction temperature rise above ambient will be less than or equal to:

$$0.275\text{W} \times 131^\circ\text{C/W} = 36^\circ\text{C}$$

The maximum junction temperature will then be equal to the junction temperature rise above ambient plus the maximum ambient temperature or:

$$T_{JMAX} = 50^\circ\text{C} + 36^\circ\text{C} = 86^\circ\text{C}$$

*For more detailed applications information, see the LT1312 Single PCMCIA VPP Driver/Regulator data sheet.*

TYPICAL APPLICATIONS

Dual Slot PCMCIA Interface to CL-PD6720

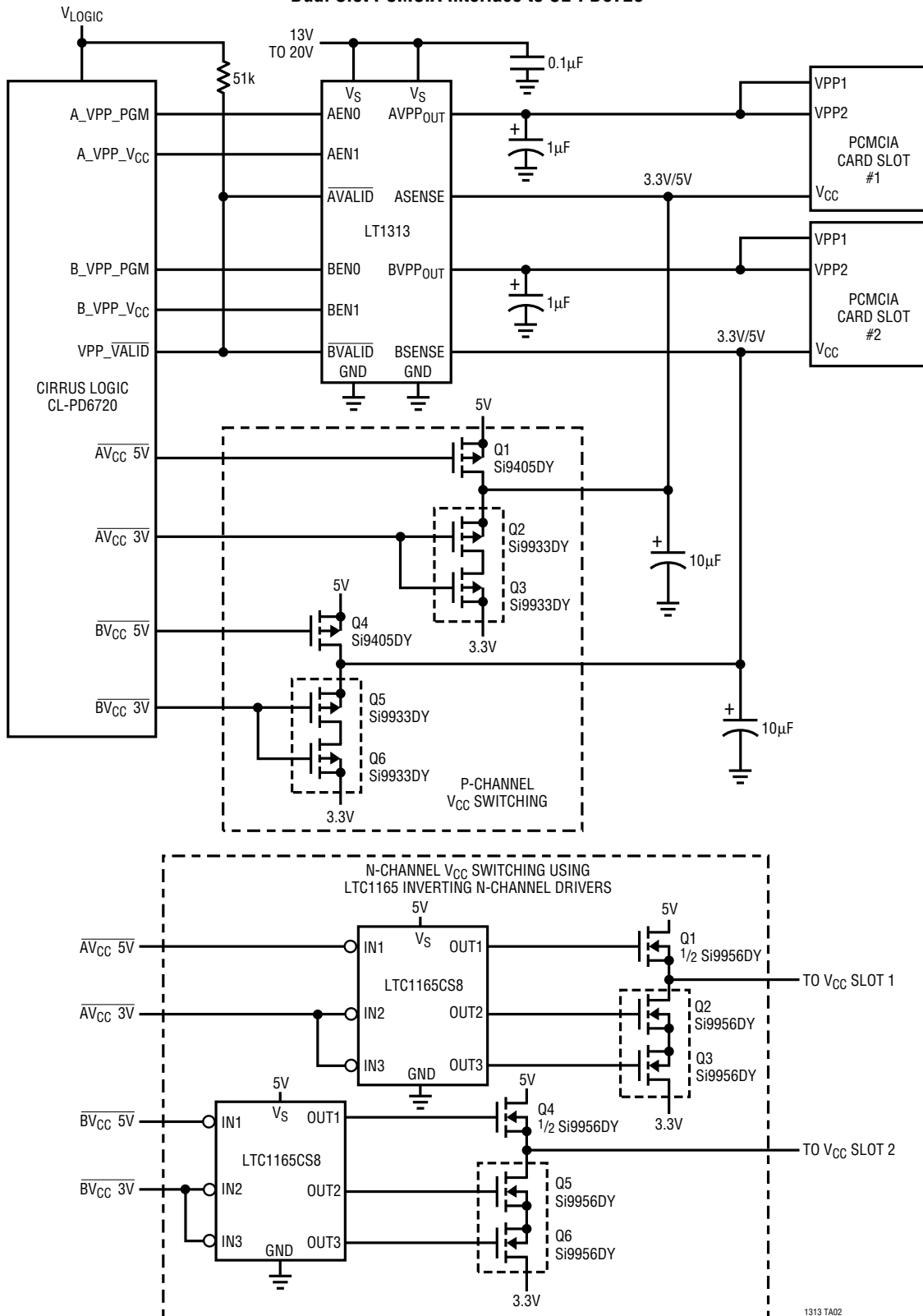

# TYPICAL APPLICATIONS

### Dual Slot PCMCIA Interface to "365" Type Controller

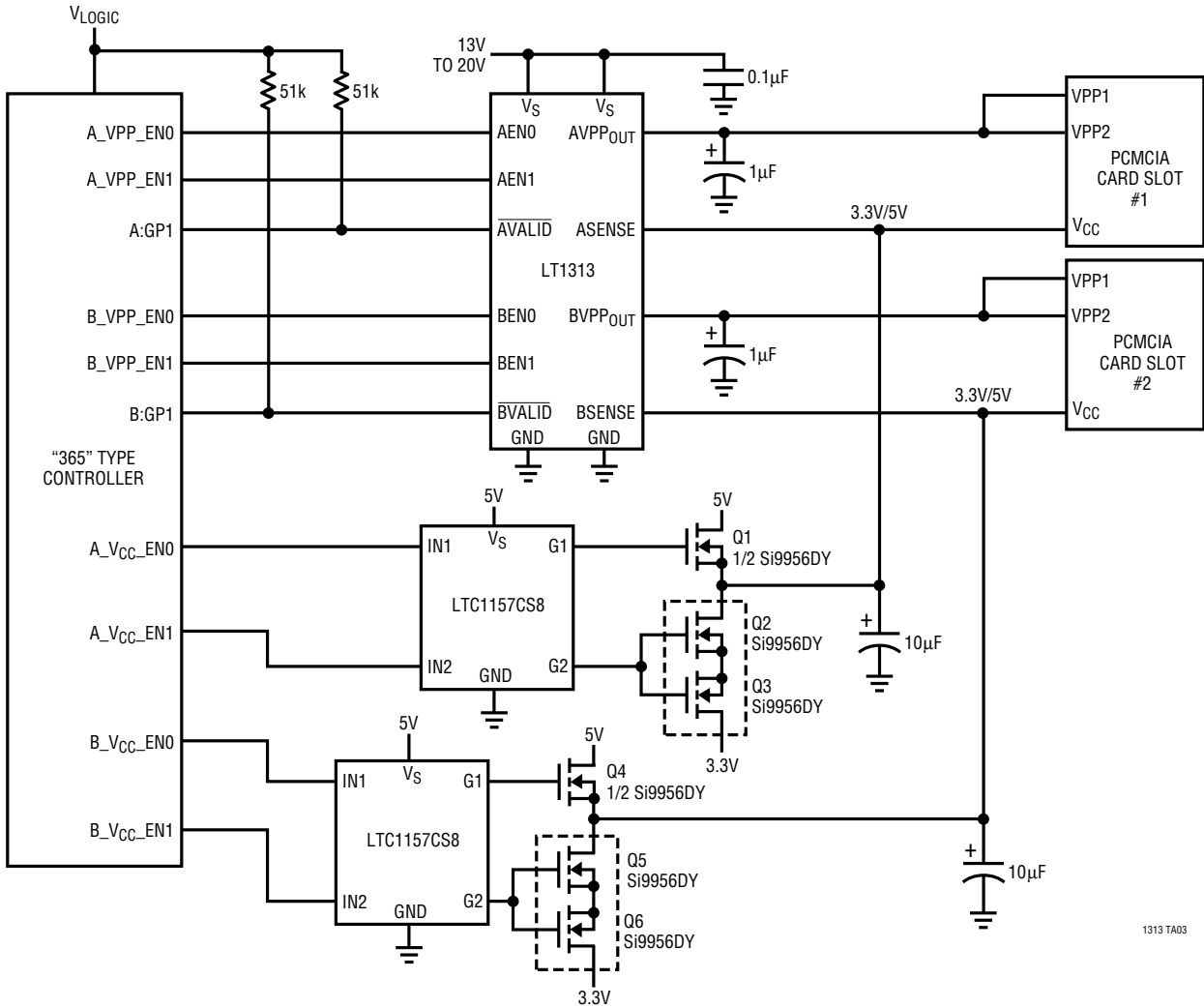

1313 TA03

**TYPICAL APPLICATIONS**

**Dual Slot PCMCIA Driver/Regulator Powered from Auxiliary Winding on 5V Inductor of LTC1142HV Dual 5V/3.3V Switching Regulator**

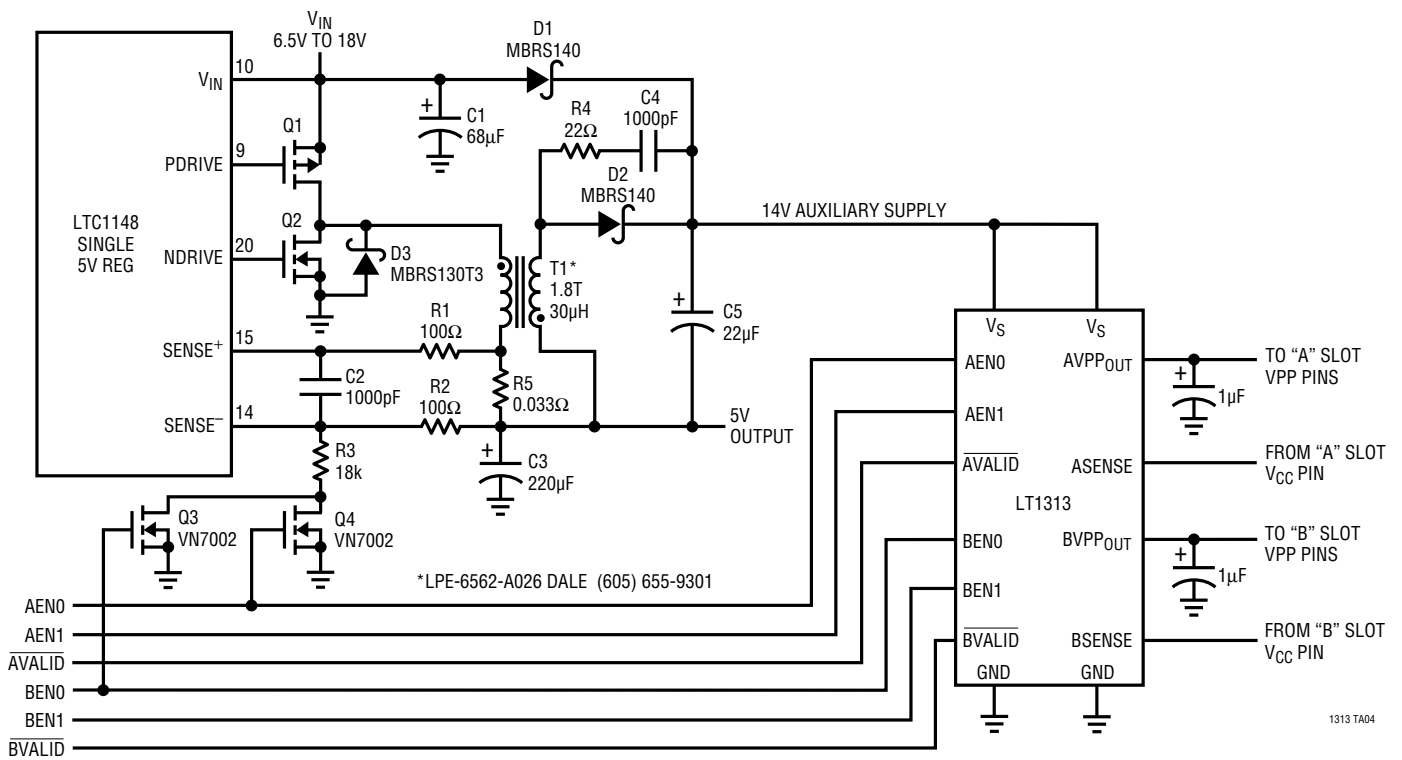

NOTE: SEE LT1312 DATA SHEET APPLICATIONS SECTION FOR FURTHER DETAILS ON THIS CIRCUIT

**PACKAGE DESCRIPTION** Dimensions in inches (millimeters) unless otherwise noted.

**S Package  
16-Lead Narrow Plastic SOIC**

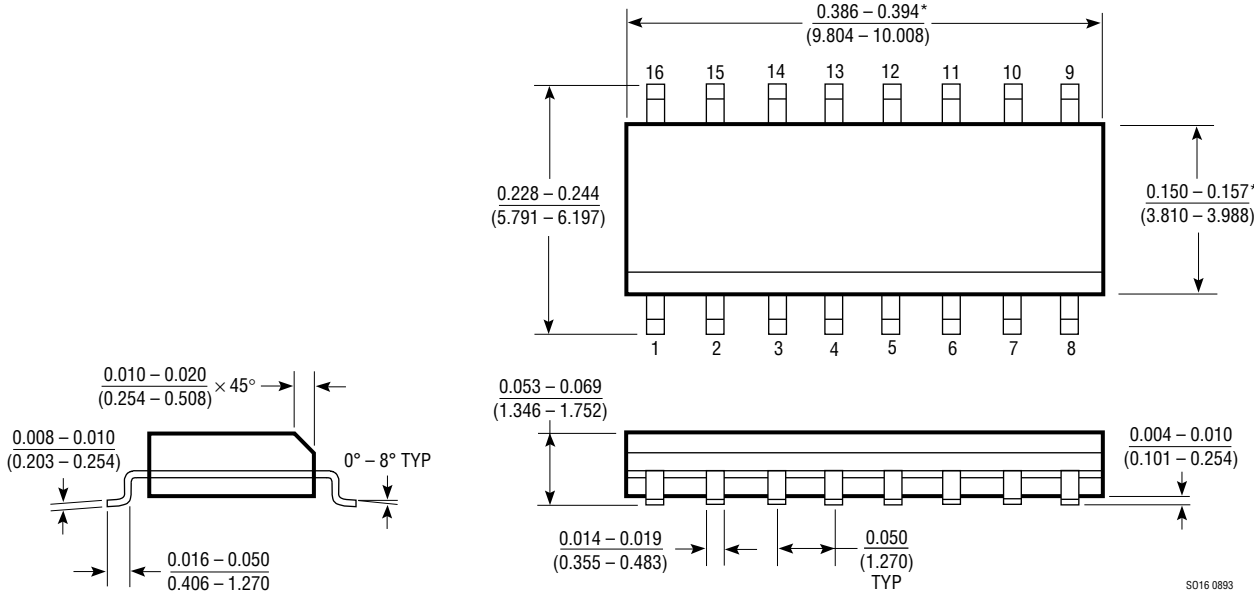

\*THESE DIMENSIONS DO NOT INCLUDE MOLD FLASH OR PROTRUSIONS.  
MOLD FLASH OR PROTRUSIONS SHALL NOT EXCEED 0.006 INCH (0.15mm).

SD16 0893

LT1313

---

## RELATED PARTS

See PCMCIA Product Family table on the first page of this data sheet.