



Chipsmall Limited consists of a professional team with an average of over 10 year of expertise in the distribution of electronic components. Based in Hongkong, we have already established firm and mutual-benefit business relationships with customers from,Europe,America and south Asia,supplying obsolete and hard-to-find components to meet their specific needs.

With the principle of “Quality Parts,Customers Priority,Honest Operation,and Considerate Service”,our business mainly focus on the distribution of electronic components. Line cards we deal with include Microchip,ALPS,ROHM,Xilinx,Pulse,ON,Everlight and Freescale. Main products comprise IC,Modules,Potentiometer,IC Socket,Relay,Connector.Our parts cover such applications as commercial,industrial, and automotives areas.

We are looking forward to setting up business relationship with you and hope to provide you with the best service and solution. Let us make a better world for our industry!



## Contact us

Tel: +86-755-8981 8866 Fax: +86-755-8427 6832

Email & Skype: info@chipsmall.com Web: www.chipsmall.com

Address: A1208, Overseas Decoration Building, #122 Zhenhua RD., Futian, Shenzhen, China



# Micropower DC/DC Converter with Programmable Peak Current Limit

## FEATURES

- **Precise Control of Peak Switch Current**
- **Quiescent Current:**
  - 33 $\mu$ A in Active Mode**
  - 3 $\mu$ A in Shutdown Mode**
- **Low-Battery Detector Active in Shutdown**
- Low Switch  $V_{CESAT}$ : 300mV at 500mA
- 8-Lead MSOP and SO Packages
- Operates with  $V_{IN}$  as Low as 1.5V
- Logic Level Shutdown Pin

## APPLICATIONS

- Battery Backup
- LCD Bias
- Low Power –48V to 5V/3.3V Converters

## DESCRIPTION

The LT<sup>®</sup>1316 is a micropower step-up DC/DC converter that operates from an input voltage as low as 1.5V. A programmable input current limiting function allows precise control of peak switch current. Peak switch current can be set to any value between 30mA and 500mA by adjusting one resistor. This is particularly useful for DC/DC converters operating from high source impedance inputs such as lithium coin cells or telephone lines.

The fixed off-time, variable on-time regulation scheme results in quiescent current of only 33 $\mu$ A in active mode. Quiescent current decreases to 3 $\mu$ A in shutdown with the low-battery detector still active.

The LT1316 is available in 8-lead MSOP and SO packages.

LT, LTC and LT are registered trademarks of Linear Technology Corporation.

## TYPICAL APPLICATION

2-Cell to 5V Step-Up Converter

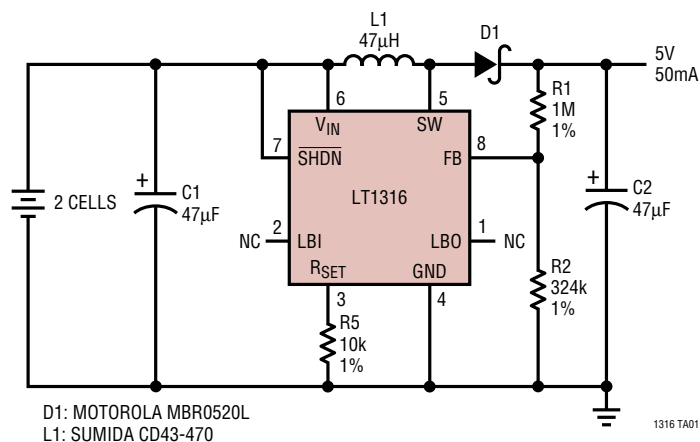

Efficiency vs Load Current

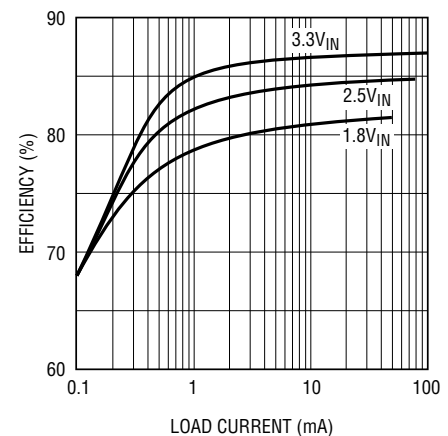

## ABSOLUTE MAXIMUM RATINGS

$V_{IN}$ Voltage .....	12V
SW Voltage .....	-0.4V to 30V
FB Voltage .....	$V_{IN} + 0.3V$
$R_{SET}$ Voltage .....	5V
SHDN Voltage .....	6V
LBI Voltage .....	$V_{IN}$
LBO Voltage .....	12V
Maximum Switch Current .....	750mA
Maximum Junction Temperature .....	125°C
Operating Temperature Range	
Commercial .....	0°C to 70°C
Extended Commercial (Note 1) .....	-40°C to 85°C
Industrial (Note 2) .....	-40°C to 85°C
Storage Temperature Range .....	-65°C to 150°C
Lead Temperature (Soldering, 10 sec) .....	300°C

## PACKAGE/ORDER INFORMATION

<p>MS8 PACKAGE 8-LEAD PLASTIC MSOP</p> <p><math>T_{JMAX} = 125^{\circ}C, \theta_{JA} = 160^{\circ}C/W</math></p>	ORDER PART NUMBER
	LT1316CMS8
	MS8 PART MARKING
<p>S8 PACKAGE 8-LEAD PLASTIC SO</p> <p><math>T_{JMAX} = 125^{\circ}C, \theta_{JA} = 120^{\circ}C/W</math></p>	ORDER PART NUMBER
	LT1316CS8 LT1316IS8
	S8 PART MARKING
	1316 1316I

Consult factory for Military grade parts.

## ELECTRICAL CHARACTERISTICS

Commercial grade 0°C to 70°C, Industrial grade -40°C to 85°C,  $V_{IN} = 2V, V_{SHDN} = V_{IN}, T_A = 25^{\circ}C$  unless otherwise noted. (Notes 1, 2)

PARAMETER	CONDITIONS	MIN	TYP	MAX	UNITS	
Minimum Operating Voltage			1.5	1.65	V	
Maximum Operating Voltage				12	V	
Quiescent Current	$V_{SHDN} = 2V$ , Not Switching		33	45 50	$\mu A$ $\mu A$	
Quiescent Current in Shutdown	$V_{SHDN} = 0V, V_{IN} = 2V$	•	3	5	$\mu A$	
	$V_{SHDN} = 0V, V_{IN} = 5V$	•	7	10	$\mu A$	
FB Pin Bias Current		•	3	30	nA	
Line Regulation	$V_{IN} = 1.8V$ to 12V	•	0.04	0.15	%/V	
LBI Input Threshold	Falling Edge	•	1.1	1.17	1.25	V
LBI Pin Bias Current		•	3	20	nA	
LBI Input Hysteresis		•	35	65	mV	
LBO Output Voltage Low	$I_{SINK} = 500\mu A$	•	0.2	0.4	V	
LBO Output Leakage Current	LBI = 1.7V, LBO = 5V	•	0.01	0.1	$\mu A$	
SHDN Input Voltage High		•	1.4		V	
SHDN Input Voltage Low		•		0.4	V	
SHDN Pin Bias Current	$V_{SHDN} = 5V$	•	2	5	$\mu A$	
	$V_{SHDN} = 0V$	•	-1	-3	$\mu A$	

## ELECTRICAL CHARACTERISTICS

Commercial grade 0°C to 70°C, Industrial grade -40°C to 85°C,  $V_{IN} = 2V$ ,  $V_{SHDN} = V_{IN}$ ,  $T_A = 25^\circ C$  unless otherwise noted. (Notes 1, 2)

PARAMETER	CONDITIONS		MIN	TYP	MAX	UNITS
Switch OFF Time	FB > 1V	●	1.4	2.0	2.6	$\mu s$
			1.1		3.0	$\mu s$
	FB < 1V			3.4		$\mu s$
Switch ON Time	Current Limit Not Asserted		4.4	6.3	8.2	$\mu s$
	1V < FB < 1.2V	●	3.4		9.5	$\mu s$
Maximum Duty Cycle	Current Limit Not Asserted		74	76	90	%
	1V < FB < 1.2V	●	73		90	%
Switch Saturation Voltage	$I_{SW} = 0.5A$	●		0.30	0.4	V
	$I_{SW} = 0.1A$	●		0.06	0.15	V
Switch Leakage	Switch Off, $V_{SW} = 5V$	●		0.1	5	$\mu A$

Commercial grade 0°C to 70°C,  $V_{IN} = 2V$ ,  $V_{SHDN} = V_{IN}$ ,  $T_A = 25^\circ C$  unless otherwise noted.

FB Comparator Trip Point		●	1.21	1.23	1.25	V
Peak Switch Current	$R_{SET} = 27.4k$ , $T_A = 25^\circ C$		90	100	110	mA
	$R_{SET} = 27.4k$ , $T_A = 0^\circ C$		90	100	115	mA
	$R_{SET} = 27.4k$ , $T_A = 70^\circ C$		70	90	110	mA
	$R_{SET} = 10K$	●	250	290	340	mA
	$R_{SET} = 121k$			25		mA

Industrial grade -40°C to 85°C,  $V_{IN} = 2V$ ,  $V_{SHDN} = V_{IN}$ ,  $T_A = 25^\circ C$  unless otherwise noted.

FB Comparator Trip Point		●	1.205	1.23	1.255	V
Peak Switch Current	$R_{SET} = 27.4k$ , $R_{SET} = 10k$	●	70	100	125	mA
		●	200	290	370	mA

The ● denotes specifications which apply over the specified temperature range.

**Note 1:** C grade device specifications are guaranteed over the 0°C to 70°C temperature range. In addition, C grade device specifications are assured

over the -40°C to 85°C temperature range by design or correlation, but are not production tested.

**Note 2:** I grade device specifications are guaranteed over the -40°C to 85°C temperature range.

## TYPICAL PERFORMANCE CHARACTERISTICS

Load Transient Response

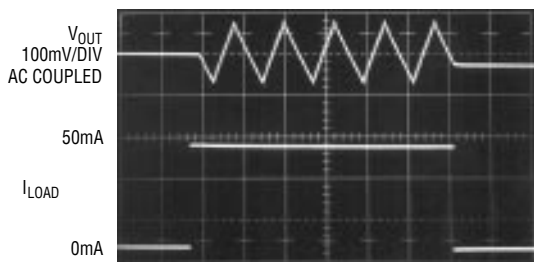

1316 001

Burst Mode™ Operation

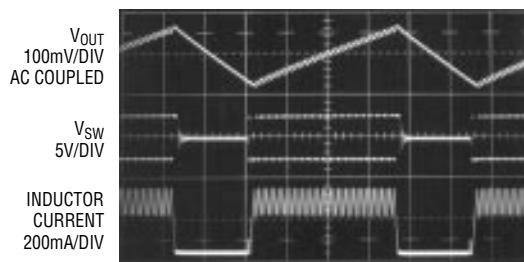

1316 002

Burst Mode IS A TRADEMARK OF LINEAR TECHNOLOGY CORPORATION.

**TYPICAL PERFORMANCE CHARACTERISTICS**

**Switch Saturation Voltage vs Switch Current**

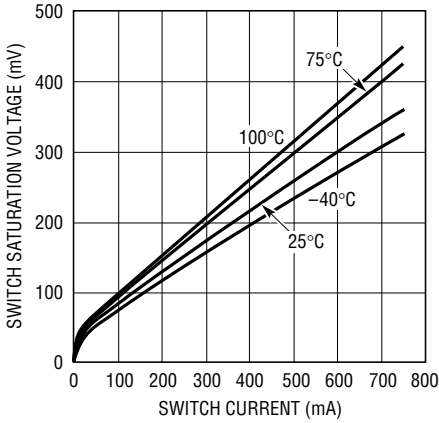

1316 G03

**LBI Pin Bias Current vs Temperature**

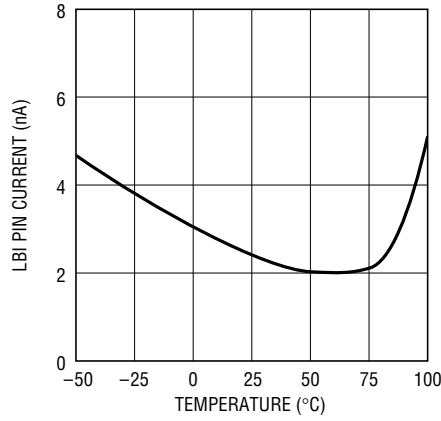

1316 G04

**Off-Time vs Temperature**

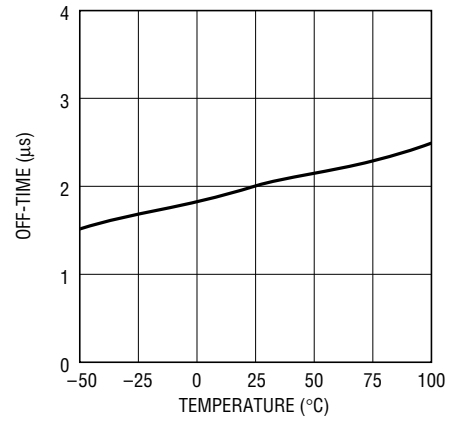

1316 G05

**Maximum On-Time vs Temperature**

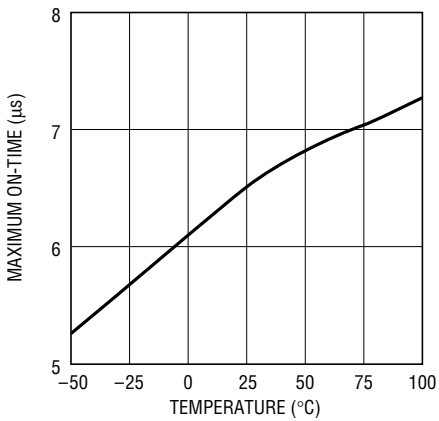

1316 G06

**Quiescent Current vs Temperature**

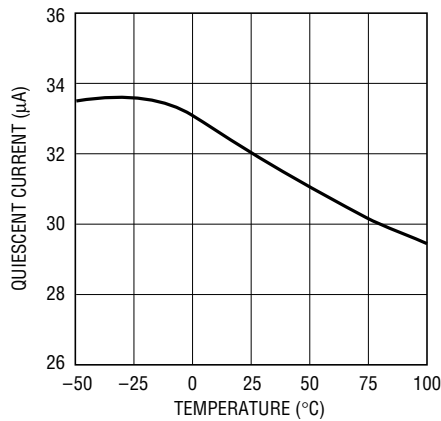

1316 G07

**Feedback Voltage vs Temperature**

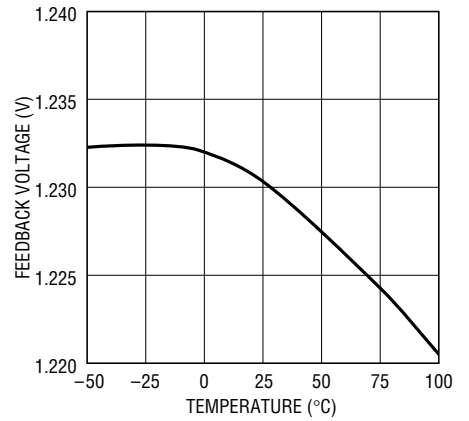

1316 G08

**FB Pin Bias Current vs Temperature**

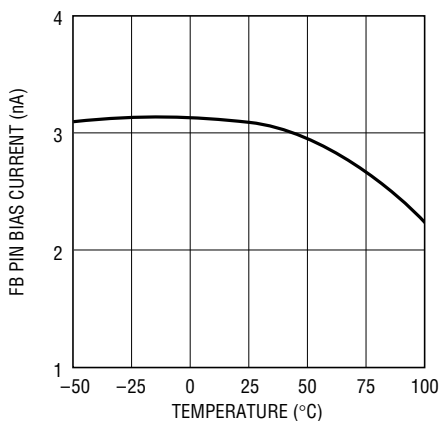

1316 G11

**Shutdown Pin Bias Current vs Shutdown Pin Voltage**

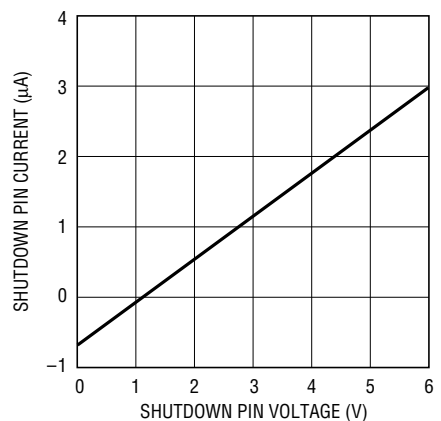

1316 G09

**Peak Switch Current vs Temperature**

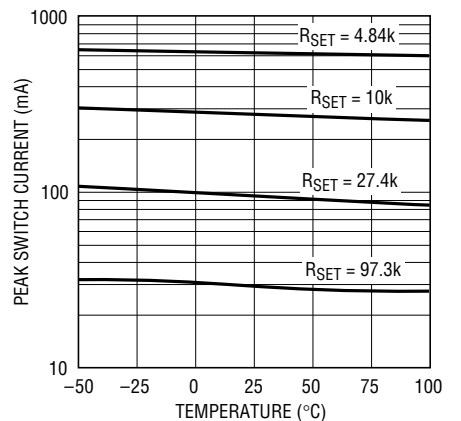

1316 G10

## PIN FUNCTIONS

**LBO (Pin 1):** Low-Battery Detector Output. Open collector can sink up to 500 $\mu$ A. Low-battery detector remains active in shutdown mode.

**LBI (Pin 2):** Low-Battery Detector Input. When voltage at this pin drops below 1.17V, LBO goes low.

**R<sub>SET</sub> (Pin 3):** A resistor between R<sub>SET</sub> and GND programs peak switch current. The resistor value should be between 3k and 150k. Do not float or short to ground. This is a high impedance node. Keep traces at this pin as short as possible. Do not put capacitance at this pin.

**GND (Pin 4):** Ground. Connect directly to ground plane.

**SW (Pin 5):** Collector of NPN Power Transistor. Keep traces at this pin as short as possible.

**V<sub>IN</sub> (Pin 6):** Input Supply. Must be bypassed close to the pin.

**SHDN (Pin 7):** Shutdown. Ground this pin to place the part in shutdown mode (only the low-battery detector remains active). Tie to a voltage between 1.4V and 6V to enable the device. SHDN pin is logic level and need only meet the logic specification (1.4V for high, 0.4V for low).

**FB (Pin 8):** Feedback Pin. Reference voltage is 1.23V. Connect resistive divider tap here. Minimize trace area at FB. Set V<sub>OUT</sub> according to:  $V_{OUT} = 1.23V(1 + R1/R2)$ .

## BLOCK DIAGRAM

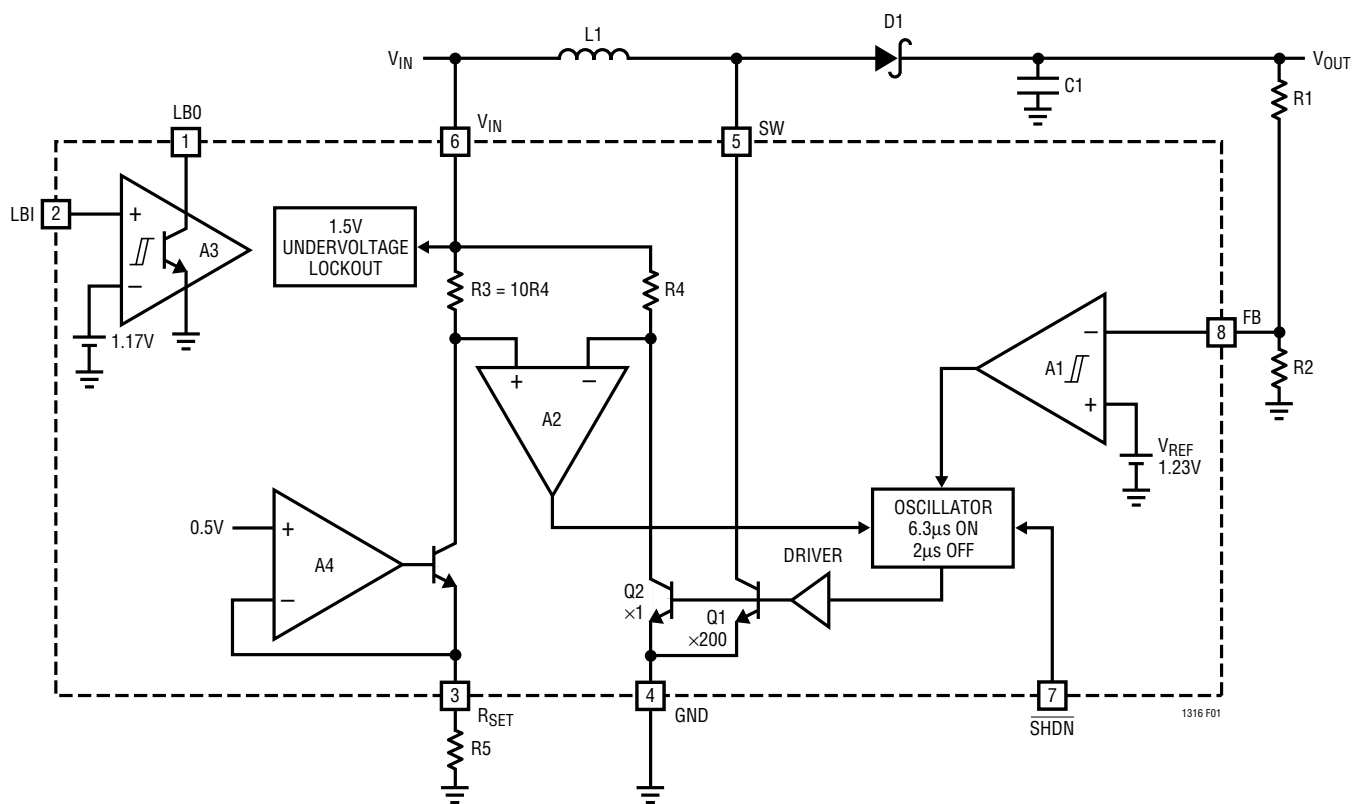

Figure 1. LT1316 Block Diagram

## APPLICATIONS INFORMATION

Table 1 simplifies component selection for commonly used input and output voltages. The methods used in determining these values are discussed in more detail later in this data sheet.

V<sub>OUT</sub> can be set using the equation:

$$V_{OUT} = 1.23 \left( \frac{R2 + R1}{R2} \right)$$

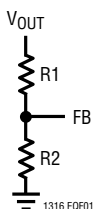
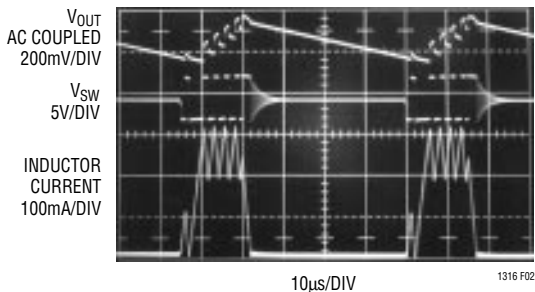

**Table 1. R<sub>SET</sub> Resistor and Inductor Values**

V <sub>IN</sub>	V <sub>OUT</sub>	LOAD CURRENT	R <sub>SET</sub> RESISTOR	INDUCTOR	PEAK SWITCH CURRENT
2	5	10mA	36.8k	100µH	80mA
2	5	25mA	18.2k	68µH	165mA
2	5	50mA	10k	47µH	320mA
2	5	75mA	6.81k	33µH	500mA
5	12	100mA	6.81k	82µH	490mA
5	28	1mA	75k	100µH	56mA
5	28	5mA	22.1k	100µH	140mA
5	28	10mA	10k	100µH	270mA

### Operation

To understand operation of the LT1316, first examine Figure 1. Comparator A1 monitors FB voltage which is V<sub>OUT</sub> divided down by resistor divider network R1/R2. When voltage at the FB pin drops below the reference voltage (1.23V), A1’s output goes high and the oscillator is enabled. The oscillator has an off-time fixed at 2µs and an on-time limited to 6.3µs. Power transistor Q1 is cycled on and off by the oscillator forcing current through the inductor to alternately ramp up and down (see Figure 2).



**Figure 2. Switching Waveforms**

During the portion of the switch cycle when Q1 is turned off, current is forced through D1 to C1 causing output voltage to rise. This switching action continues until output voltage rises enough to overcome A1’s hysteresis.

Peak switch current is set by a resistor from the R<sub>SET</sub> pin to ground. Voltage at the R<sub>SET</sub> pin is forced to 0.5V by A4 and is used to set up a constant current through R5. This current also flows through R3 which sets the voltage at the positive input of comparator A2. When Q1 turns on, the SW pin goes low and current ramps up at the rate V<sub>IN</sub>/L. Current through Q2 is equal to Q1’s current divided by 200. When current through Q2 causes the voltage drop across R4 and R3 to be equal, A2 changes state and resets the oscillator, causing Q1 to turn off. Shutdown is accomplished by grounding the SHDN pin.

The low-battery detector A3 has its own 1.17V reference and is always on. The open collector output device can sink up to 500µA. Approximately 35mV of hysteresis is built into A3 to reduce “buzzing” as the battery voltage reaches the trip level.

### Current Limit

During active mode when the part is switching, current in the inductor ramps up each switch cycle until reaching a preprogrammed current limit. This current limit value must be set by placing the appropriate resistor from the R<sub>SET</sub> pin to ground. This resistance value can be found by using Figure 3 to locate the desired DC current limit and

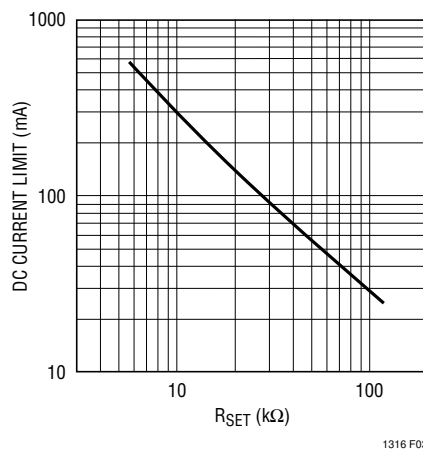

**Figure 3. DC Current Limit vs R<sub>SET</sub> Resistor**  
 Note: DC Current is the Peak Switch Current if the Power Transistor had Zero Turn-Off Delay

## APPLICATIONS INFORMATION

then adding in the amount of overshoot that will occur due to turn-off delay of the power transistor. This turn-off delay is approximately 300ns.

Peak switch current = DC current limit from graph +  $V_{IN}/L$ (turn-off delay)

### Example:

Set peak switch current to 100mA for:  $V_{IN} = 2V$ ,  
 $L = 33\mu H$

Overshoot =  $V_{IN}/L$ (turn-off delay) =  $(2/33\mu H)(300ns)$   
 = 18.2mA

Refer to  $R_{SET}$  graph and locate  
 $(100mA - 18.2mA) \approx 82mA$

$R_{SET} \approx 33k$

### Calculating Duty Cycle

For a boost converter running in continuous conduction mode, duty cycle is constrained by  $V_{IN}$  and  $V_{OUT}$  according to the equation:

$$DC = \frac{V_{OUT} - V_{IN} + V_D}{V_{OUT} - V_{SAT} + V_D}$$

where  $V_D$  = diode voltage drop  $\approx 0.4V$  and  $V_{SAT}$  = switch saturation voltage  $\approx 0.2V$ .

If the duty cycle exceeds the LT1316's minimum specified duty cycle of 0.73, the converter cannot operate in continuous conduction mode and must be designed for discontinuous mode operation.

### Inductor Selection and Peak Current Limit for Continuous Conduction Mode

Peak current and inductance determine available output power. Both must be chosen properly. If peak current or inductance is increased, output power increases. Once output power or current and duty cycle are known, peak current can be set by the following equation, assuming continuous mode operation:

$$I_{PEAK} = \frac{2(I_{OUT})}{1 - DC} \tag{1}$$

Inductance can now be calculated using the peak current:

$$L = \frac{V_{OUT} - V_{IN} + V_D}{0.4(I_{PEAK})} (t_{OFF}) \tag{2}$$

where  $t_{OFF} = 2\mu s$  and  $V_D = 0.4V$ .

As a result of equations 1 and 2, ripple current during switching will be 40% of the peak current (see Figure 2). Using these equations at the specified  $I_{OUT}$ , the part is delivering approximately 60% of its maximum output power. In other words, the part is operating on a 40% reserve. This is a safe margin to use and can be decreased if input voltage and output current are tightly controlled.

For some applications, this recommended inductor size may be too large. Inductance can be reduced but available output power will decrease. Also, ripple current during switching will increase and may cause discontinuous operation. Discontinuous operation occurs when inductor current ramps down to zero at the end of each switch cycle (see Figure 4). Shown in Figure 5 is minimum inductance vs peak current for the part to remain in continuous mode.

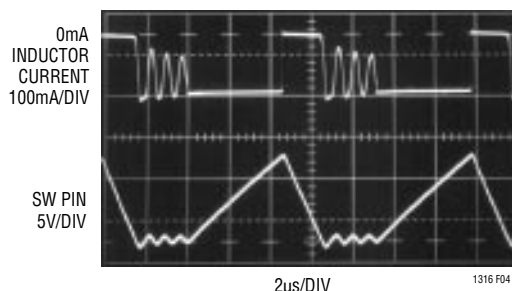

Figure 4. Discontinuous Mode Operation

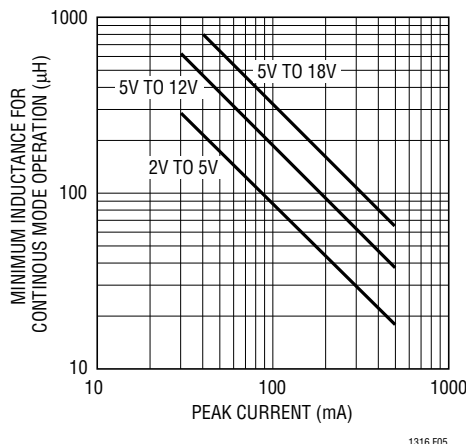

Figure 5. Minimum Inductance vs Peak Current for Continuous Mode Operation

## APPLICATIONS INFORMATION

### Discontinuous Mode Operation

A boost converter with a high  $V_{OUT}:V_{IN}$  ratio operates with a high duty cycle in continuous mode. For duty cycles exceeding the LT1316's guaranteed minimum specification of 0.73, the circuit will need to be designed for discontinuous operation. Additionally, very low peak current limiting below 50mA may necessitate operating in this mode unless high inductance values are acceptable. When operating in discontinuous mode, a different equation governs available output power. For each switch cycle, the inductor current ramps down to zero, completely releasing the stored energy. Energy stored in the inductor at any time is equal to  $1/2 LI^2$ . Because this energy is released each cycle, the equation for maximum power out is:

$$P_{OUT(MAX)} = 1/2L(I_{PEAK}^2)f$$

$$\text{Where } f = \left( \frac{1}{\frac{I_{PEAK}(L)}{V_{IN} - V_{SAT}} + t_{OFF}} \right)$$

When designing for very low peak currents (<50mA), the inductor size needs to be large enough so that on-time is a least  $1\mu s$ . On-time can be calculated by the equation:

$$\text{On-Time} = \left( \frac{I_{PEAK} \cdot L}{(V_{IN} - V_{SAT})} \right)$$

where  $V_{SAT} = 0.2V$ .

Also, at these low current levels, current overshoot due to power transistor turn-off delay will be a significant portion of peak current. Increasing inductor size will keep this to a minimum.

#### Design Example 1

Requirements:  $V_{IN} = 2V$ ,  $V_{OUT} = 5V$  and  $I_{LOAD} = 10mA$ .

1. Find duty cycle

$$DC = \left( \frac{V_{OUT} - V_{IN} + V_D}{V_{OUT} - V_{SAT} + V_D} \right) = \left( \frac{5 - 2 + 0.4}{5 - 0.2 + 0.4} \right) = 0.654$$

Because duty cycle is less than the LT1316 minimum specification (0.73), the circuit can be designed for continuous operation.

$$2. I_{PEAK} = \frac{2(I_{OUT})}{1 - DC} = \frac{2(10mA)}{1 - 0.654} = 58mA$$

3. Find L

$$L = \left( \frac{V_{OUT} - V_{IN} + V_D}{0.4(I_{PEAK})} \right) t_{OFF}$$

$$= \left( \frac{5 - 2 + 0.4}{0.4(58mA)} \right) 2\mu s$$

$$= 293\mu H$$

4. Find  $R_{SET}$  resistor

$$\text{Overshoot} = \left( \frac{V_{IN}}{L} \right) 300ns$$

$$= \left( \frac{2}{330\mu H} \right) = 1.8mA$$

Find  $R_{SET}$  from Figure 3 for  $58mA - 1.8mA = 56.2mA$

$R_{SET} \approx 47k$

#### Design Example 2

Requirements:  $V_{IN} = 3.3V$ ,  $V_{OUT} = 28V$  and  $I_{LOAD} = 5mA$ .

1. Find duty cycle:

$$DC = \left( \frac{V_{OUT} - V_{IN} + V_D}{V_{OUT} - V_{SAT} + V_D} \right) = \left( \frac{28 - 3.3 + 0.4}{28 - 0.2 + 0.4} \right) = 0.89$$

Because duty cycle exceeds LT1316 minimum specification of 73%, the circuit must be designed for discontinuous operation.

2. Find  $P_{OUT(MAX)}$

Multiply  $P_{OUT}$  by 1.4 to give a safe operating margin  
 $P_{OUT(MAX)} = P_{OUT}(1.4) = (5mA)(28V)(1.4) = 0.196W$

3. Set the on-time to the data sheet minimum of  $3.4\mu s$  and find L

$$L = \frac{(t_{ON}^2)(V_{IN} - V_{SAT})^2}{2P_{OUT(MAX)}(t_{ON} + t_{OFF})}$$

$$= \frac{(3.4\mu s^2)(3.3 - 0.2)^2}{2(0.196W)(3.4\mu s + 2\mu s)} = 52\mu H$$

## APPLICATIONS INFORMATION

4. Find  $I_{PEAK}$  for 3.4 $\mu$ s on-time

$$I_{PEAK} = \frac{t_{ON}(V_{IN} - V_{SAT})}{L} = \frac{3.4\mu s(3.3 - 0.2)}{52\mu H}$$

$$= 0.202A$$

5. Find  $R_{SET}$  resistor

$$\text{Overshoot} = \left(\frac{V_{IN}}{L}\right) 300ns$$

$$= \left(\frac{3.3}{52\mu H}\right) 300ns = 19mA$$

Find  $R_{SET}$  from Figure 3 for 0.202A – 19mA = 0.183A

$$R_{SET} \approx 13k$$

These discontinuous mode equations are designed to minimize peak current at the expense of inductor size. If smaller inductors are desired peak current must be increased.

### Capacitor Selection

Low ESR (Equivalent Series Resistance) capacitors should be used at the output of the LT1316 to minimize output ripple voltage. High quality input bypassing is also required. For surface mount applications AVX TPS series tantalum capacitors are recommended. These have been specifically designed for switch mode power supplies and have low ESR along with high surge current ratings.

For through-hole applications Sanyo OS-CON capacitors offer extremely low ESR in a small package size. If peak switch current is reduced using the  $R_{SET}$  pin, capacitor requirements can be eased and smaller, higher ESR units can be used. Ordinary generic capacitors can generally be used when peak switch current is less than 100mA, although output voltage ripple may increase.

### Diodes

Most of the application circuits on this data sheet specify the Motorola MBR0520L surface mount Schottky diode. This 0.5A, low drop diode suits the LT1316 well. In lower current applications, a 1N4148 can be used although efficiency will suffer due to the higher forward drop. This effect is particularly noticeable at low output voltages. For higher output voltage applications, such as LCD bias generators, the extra drop is a small percentage of the output voltage so the efficiency penalty is small. The low cost of the 1N4148 makes it attractive wherever it can be used. In through-hole applications the 1N5818 is the all around best choice.

### Lowering Output Ripple Voltage

To obtain lower output ripple voltage, a small feedforward capacitor of about 50pF to 100pF may be placed from  $V_{OUT}$  to FB as detailed in Figure 6. Ripple voltages with and without the added capacitor are pictured in Figures 7 and 8.

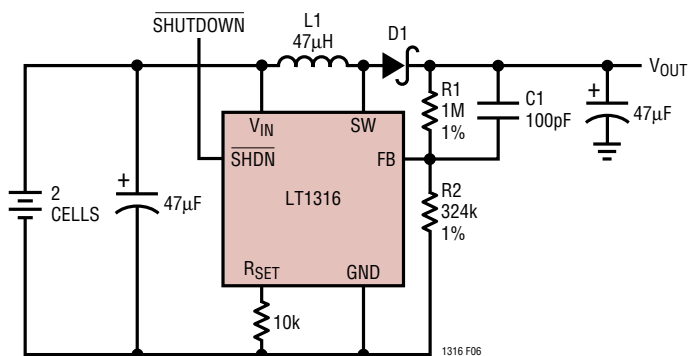
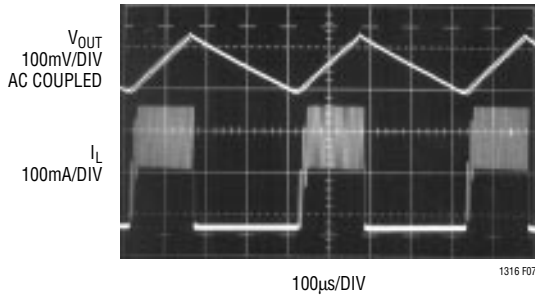
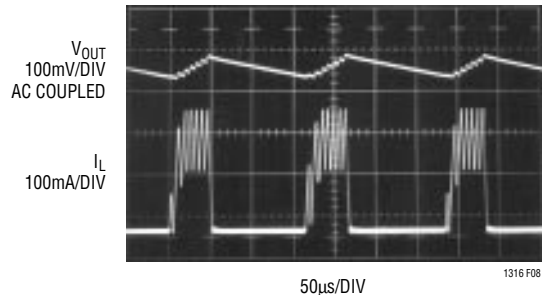

Figure 6. 2-Cell to 5V Step-Up Converter with Reduced Output Ripple Voltage

**APPLICATIONS INFORMATION**



**Figure 7. Switching Waveforms for the Circuit Shown in Figure 7 Without C1. The Output Ripple Voltage is Approximately 140mV<sub>p-p</sub>**



**Figure 8. By Adding C1, Output Ripple Voltage is Reduced to Less Than 80mV<sub>p-p</sub>**

**Layout/Input Bypassing**

The LT1316's high speed switching mandates careful attention to PC board layout. Suggested component placement is shown in Figure 9. The input supply must have low impedance at AC and the input capacitor should be placed as indicated in the figure. The value of this capacitor depends on how close the input supply is to the IC. In situations where the input supply is more than a few inches away from the IC, a 47µF to 100µF solid tantalum bypass capacitor is required. If the input supply is close to the IC, a 1µF ceramic capacitor can be used instead. The LT1316 switches current in pulses up to 0.5A, so a low impedance supply must be available. If the power source (for example, a 2 AA cell battery) is within 1 or 2 inches of the IC, the battery itself provides bulk capacitance and the

1µF ceramic capacitor acts to smooth voltage spikes at switch turn-on and turn-off. If the power source is far away from the IC, inductance in the power source leads results in high impedance at high frequency. A local high capacitance bypass is then required to restore low impedance at the IC.

**Low-Battery Detector**

The LT1316 contains an independent low-battery detector that remains active when the device is shut down. This detector, actually a hysteretic comparator, has an open collector output that can sink up to 500µA. The comparator also operates below the switcher's undervoltage lock-out threshold, operating until  $V_{IN}$  reaches approximately 1.4V.

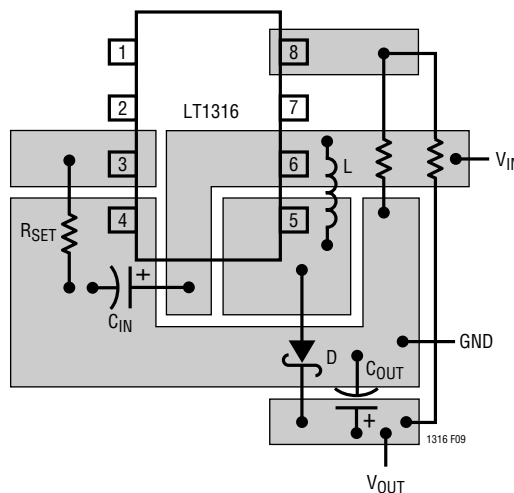

**Figure 9. Suggested PC Layout**

TYPICAL APPLICATIONS

Nonisolated -48V to 5V Flyback Converter

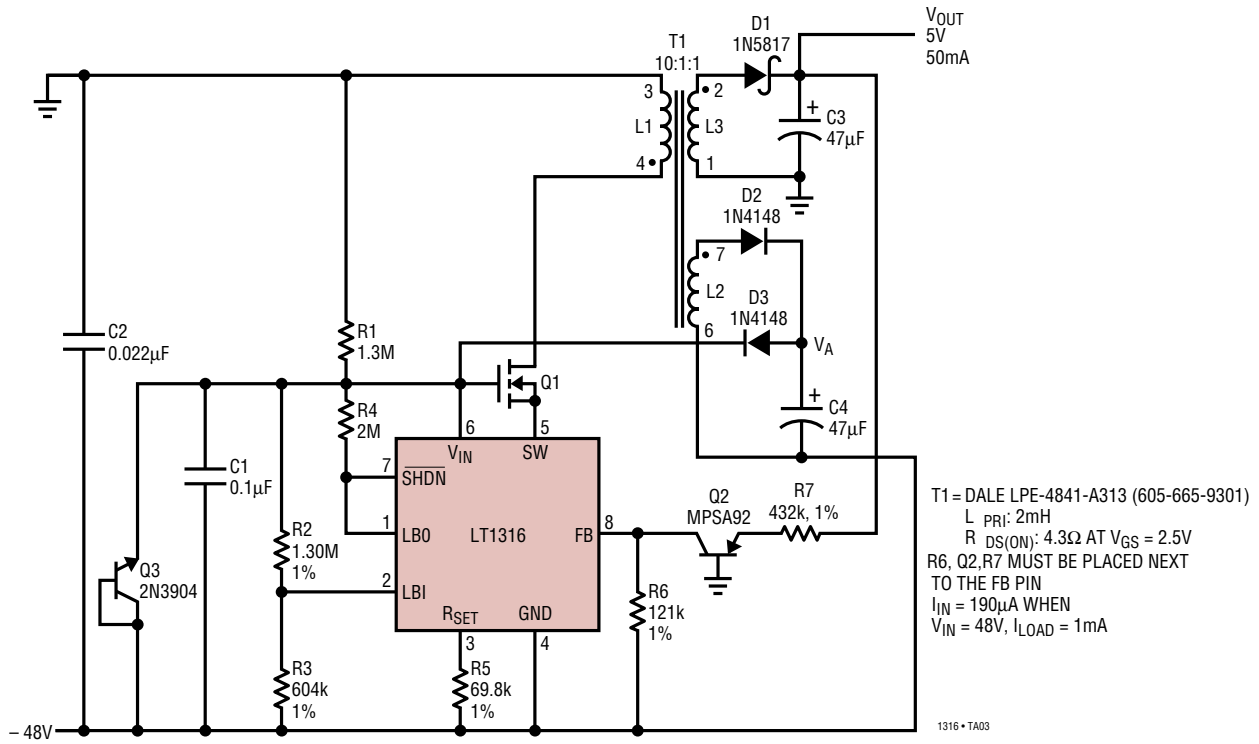

Efficiency vs Load Current

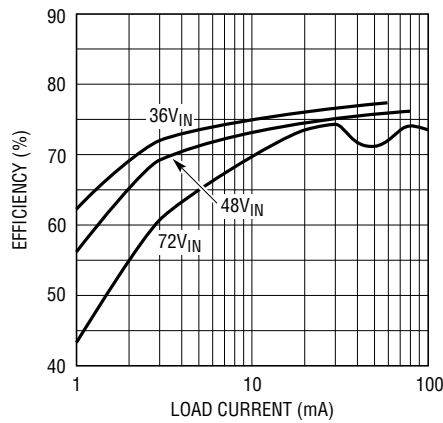

TYPICAL APPLICATIONS

Positive-to-Negative Converter for LCD Bias

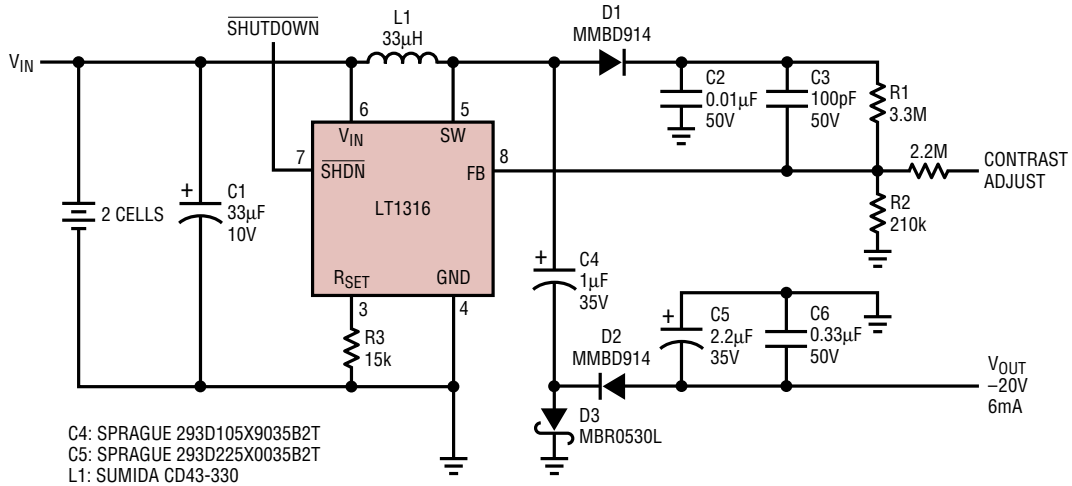

1316 TA06

Battery-Powered Solenoid Driver

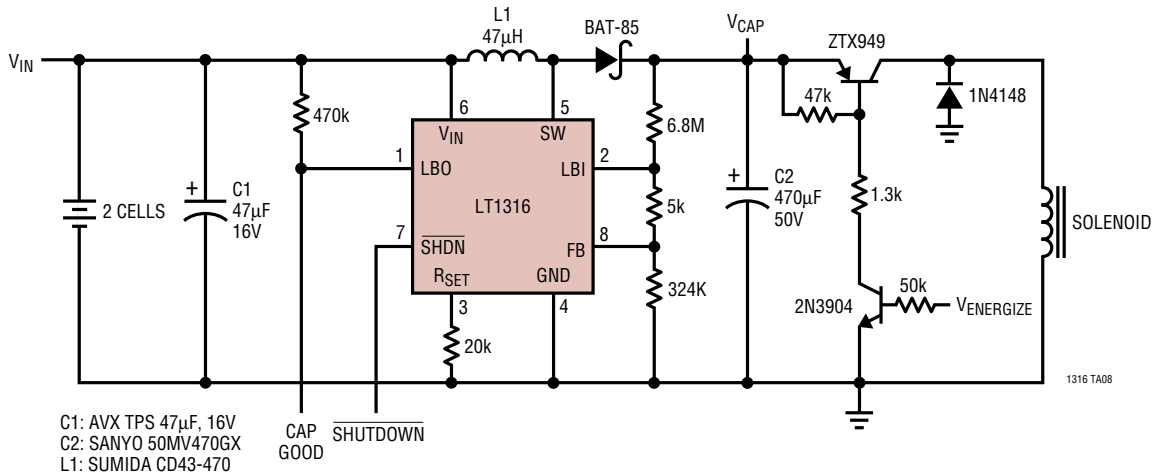

1316 TA08

When Solenoid Is Energized ( $V_{ENERGIZE}$  High) Peak Input Current Remains Low and Controlled, Maximizing Battery Life

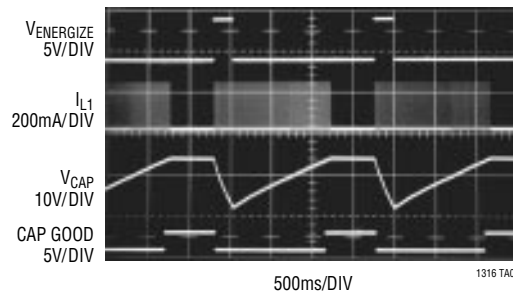

1316 TA09

# TYPICAL APPLICATIONS

## Super Cap Backup Supply

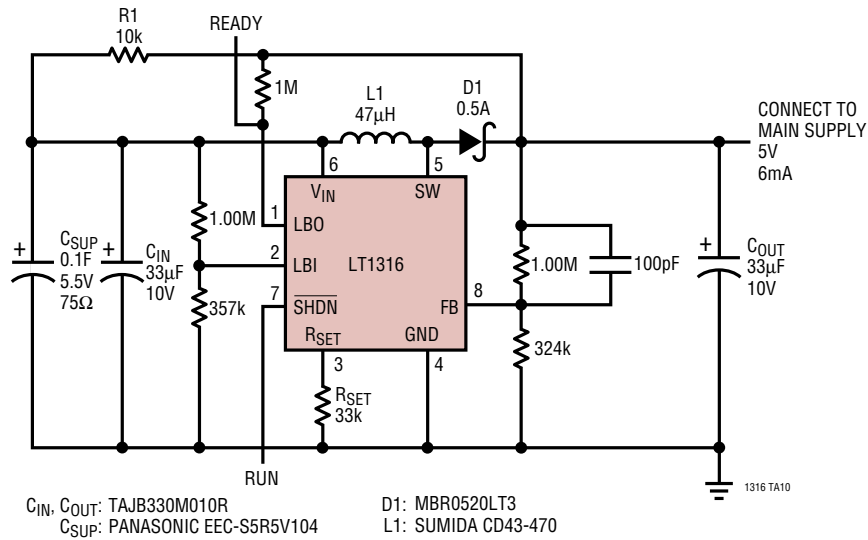

## 50V to 6V Isolated Flyback Converter

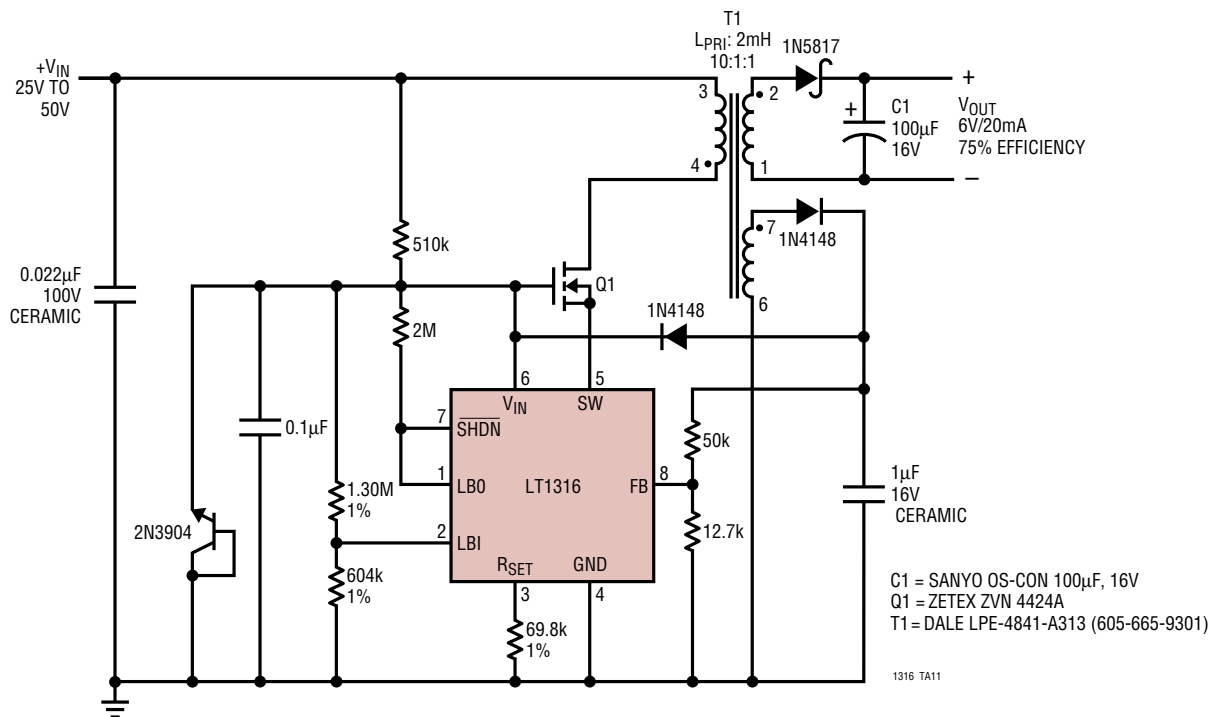

TYPICAL APPLICATIONS

LCD Bias Generator with Output Disconnect in Shutdown

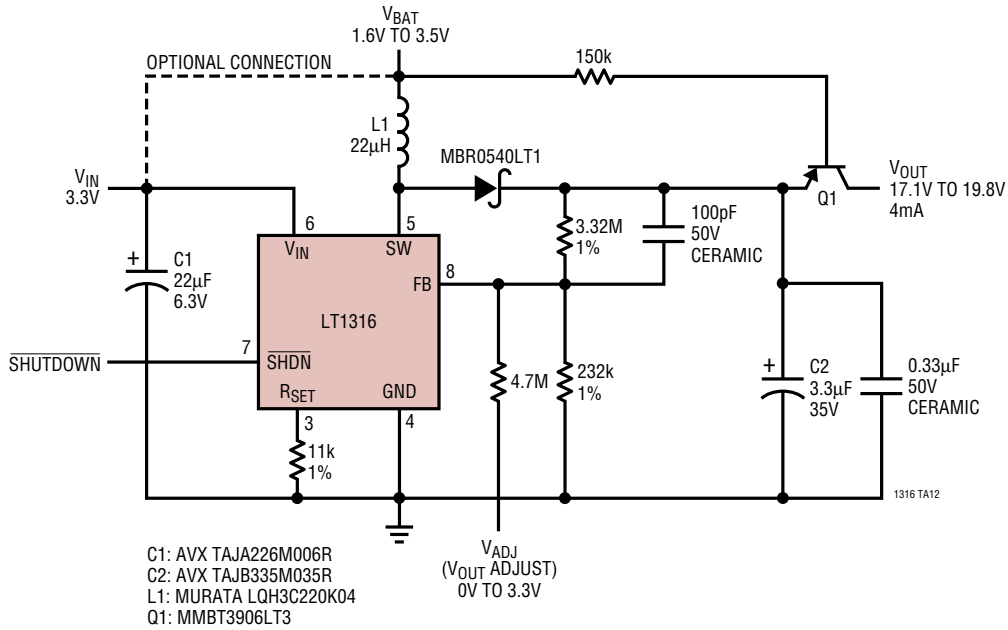

Universal Serial Bus (USB) to 5V/100mA DC/DC Converter

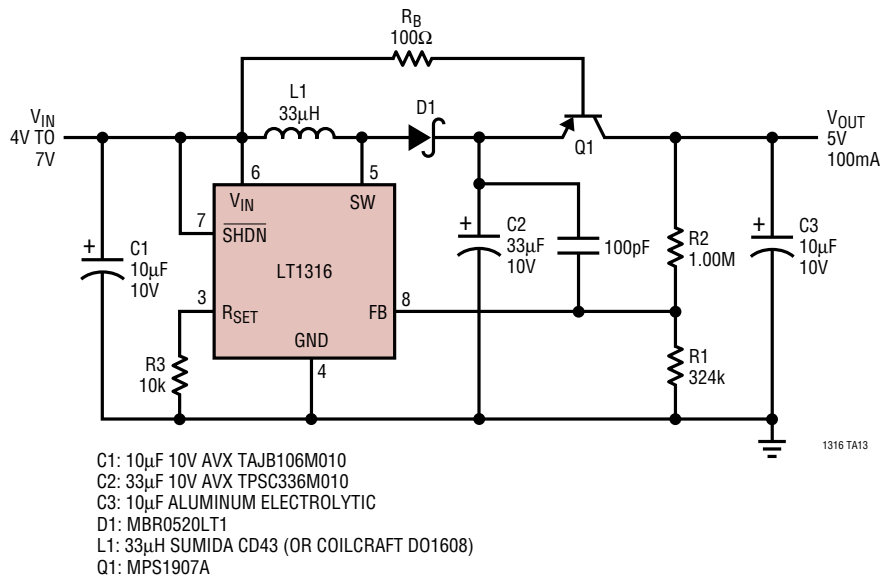

**PACKAGE DESCRIPTION** Dimensions in inches (millimeter) unless otherwise noted.

**MS8 Package**  
**8-Lead Plastic MSOP**  
 (LTC DWG # 05-08-1660)

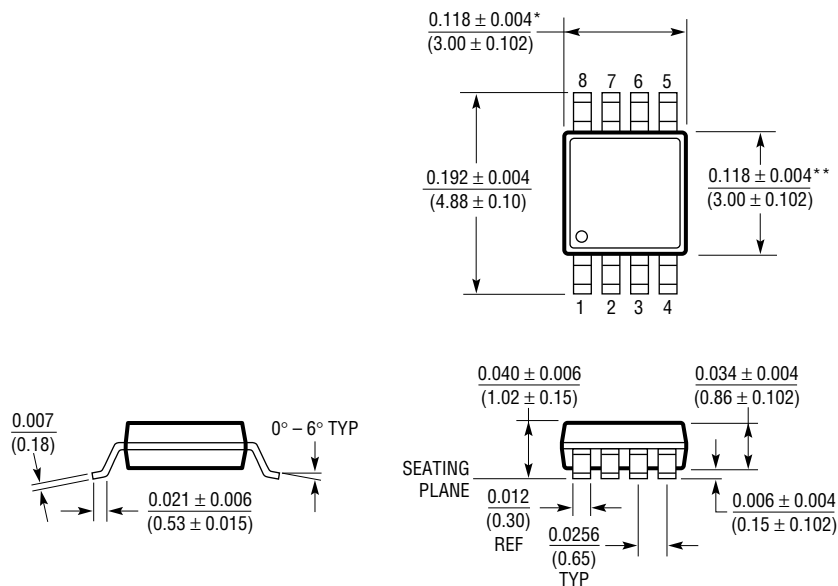

\* DIMENSION DOES NOT INCLUDE MOLD FLASH, PROTRUSIONS OR GATE BURRS. MOLD FLASH, PROTRUSIONS OR GATE BURRS SHALL NOT EXCEED 0.006" (0.152mm) PER SIDE

\*\* DIMENSION DOES NOT INCLUDE INTERLEAD FLASH OR PROTRUSIONS. INTERLEAD FLASH OR PROTRUSIONS SHALL NOT EXCEED 0.006" (0.152mm) PER SIDE

MSOP (MS8) 1197

**S8 Package**  
**8-Lead Plastic Small Outline (Narrow 0.150)**  
 (LTC DWG # 05-08-1610)

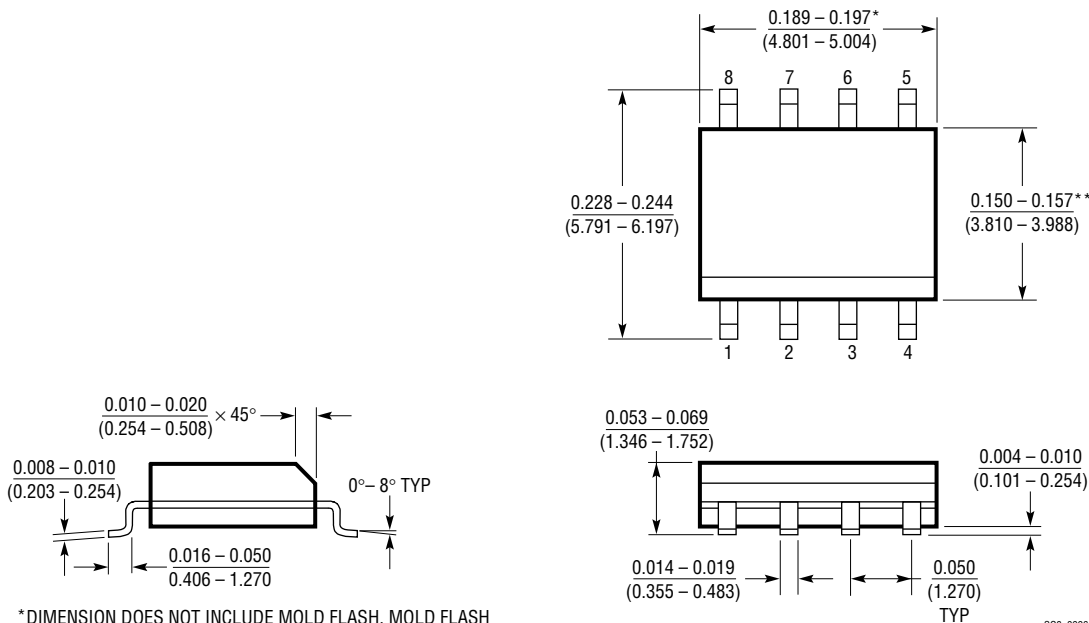

\* DIMENSION DOES NOT INCLUDE MOLD FLASH. MOLD FLASH SHALL NOT EXCEED 0.006" (0.152mm) PER SIDE

\*\* DIMENSION DOES NOT INCLUDE INTERLEAD FLASH. INTERLEAD FLASH SHALL NOT EXCEED 0.010" (0.254mm) PER SIDE

S08 0996

TYPICAL APPLICATIONS

Low Profile 2 Cell-to-28V Converter for LCD Bias

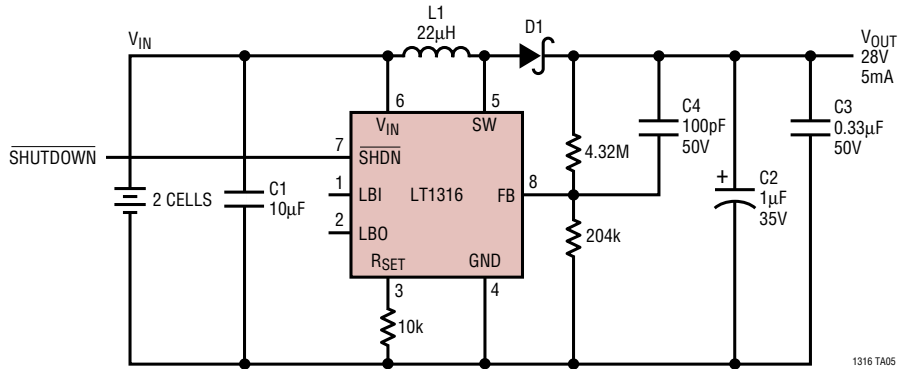

- C1: MURATA GRM235Y5V106Z010
- C2: SPRAGUE 293D105X9035B2T
- C3: 0.33µF CERAMIC, 50V
- C4: 100pF CERAMIC, 50V
- D1: BAT-54
- L1: MURATA LQH3C220K04

Bipolar LCD Bias Supply

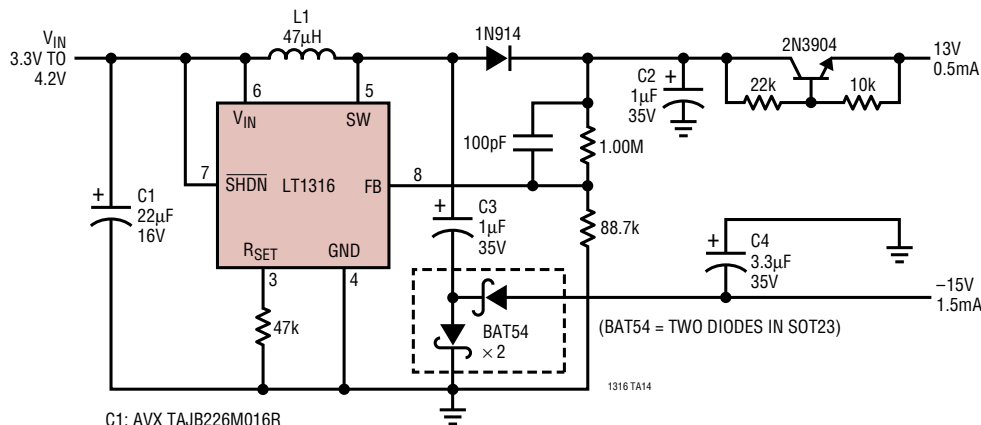

- C1: AVX TAJB226M016R
- C2, C3: AVX TAJA105K035R
- C4: AVX TAJB335M035R
- L1: MURATA LQH3C470

RELATED PARTS

PART NUMBER	DESCRIPTION	COMMENTS
LTC <sup>®</sup> 1163	Triple High Side Driver for 2-Cell Inputs	1.8V Minimum Input, Drives N-Channel MOSFETs
LTC1174	Micropower Step-Down DC/DC Converter	94% Efficiency, 130µA I <sub>Q</sub> , 9V to 5V at 300mA
LT1302	High Output Current Micropower DC/DC Converter	5V/600mA from 2V, 2A Internal Switch, 200µA I <sub>Q</sub>
LT1304	2-Cell Micropower DC/DC Converter	Low-Battery Detector Active in Shutdown, 5V at 200mA for 2 Cells
LT1307	Single Cell Micropower 600kHz PWM DC/DC Converter	3.3V at 75mA from 1 Cell
LTC1440/1/2	Ultralow Power Single/Dual Comparators with Reference	2.8µA I <sub>Q</sub> , Adjustable Hysteresis
LTC1516	2-Cell to 5V Regulated Charge Pump	12µA I <sub>Q</sub> , No Inductors, 5V at 50mA from 3V Input
LT1521	Micropower Low Dropout Linear Regulator	500mV Dropout, 300mA Current, 12µA I <sub>Q</sub>