



Chipsmall Limited consists of a professional team with an average of over 10 year of expertise in the distribution of electronic components. Based in Hongkong, we have already established firm and mutual-benefit business relationships with customers from,Europe,America and south Asia,supplying obsolete and hard-to-find components to meet their specific needs.

With the principle of "Quality Parts,Customers Priority,Honest Operation,and Considerate Service",our business mainly focus on the distribution of electronic components. Line cards we deal with include Microchip,ALPS,ROHM,Xilinx,Pulse,ON,Everlight and Freescale. Main products comprise IC,Modules,Potentiometer,IC Socket,Relay,Connector.Our parts cover such applications as commercial,industrial, and automotives areas.

We are looking forward to setting up business relationship with you and hope to provide you with the best service and solution. Let us make a better world for our industry!



## Contact us

Tel: +86-755-8981 8866 Fax: +86-755-8427 6832

Email & Skype: info@chipsmall.com Web: www.chipsmall.com

Address: A1208, Overseas Decoration Building, #122 Zhenhua RD., Futian, Shenzhen, China



# Switching Gas Discharge Tubes

## Gas Plasma Voltage Dependent Switches

### RoHS LT Series

The LT Series is a 2-terminal bi-directional, voltage triggered switch is designed for ignition circuits used in high pressure HID lighting. Switching voltages for the devices are fixed depending on the part number selected. The gas plasma trigger technology offers very fast switching speeds, resulting in significantly better di/dt values when compared to silicon based SIDAC devices. Due to the high switching voltage of the devices, step-up transformer sizes and specifications can be reduced saving cost, size and weight.

#### Features

- RoHS compliant
- Ceramic chamber for ultimate reliability.
- Very high switching speed once switching voltage has been reached, resulting in high di/dt to be generated enabling the best performance to be extracted from ignition transformers.
- Tape and reel to EIA 481-1

#### Applications

- For switching stored electrical energy (such as capacitive discharge) at predetermined voltages.
- Designed for ignition circuits used in high pressure HID lighting.

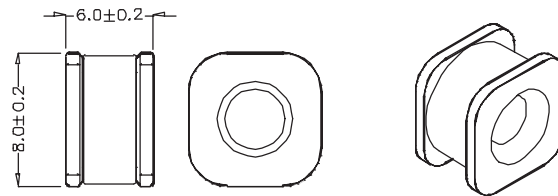
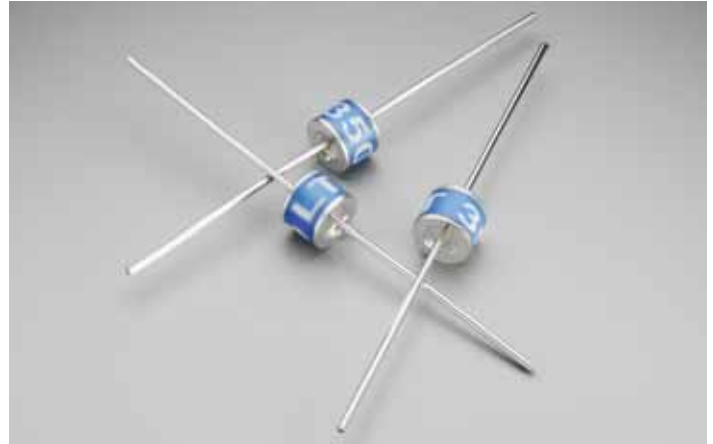

LT xxx SM

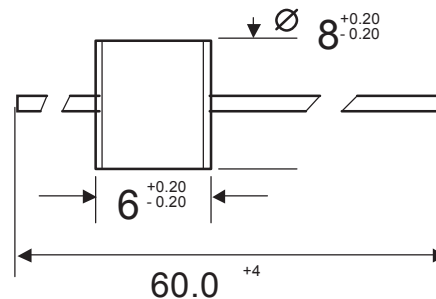

LTxxx A

Dimensions in mm

#### ORDERING INFORMATION

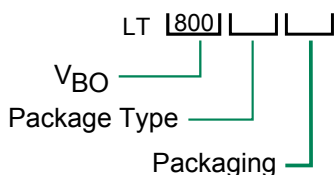

A= Axial lead, tape and Reel  
SM= Surface Mount

#### Mechanical Specifications:

- Weight (ballast circuit only):** 1.42g (0.049oz.)
- Materials:** Electrode Base: Copper alloy  
Electrode Plating material: Bright Sn  
Body: Ceramic
- Device Marking:** Littelfuse 'LF' marking, voltage and product code (red print)

# Switching Gas Discharge Tubes

## Gas Plasma Voltage Dependent Switches

### RoHS LT Series

#### Device Ratings and Specifications

Part Number	$V_{BO}^{(1)}$ (V)	$V_S$ (V)	$V_T @ 5A$ (V)	$I_{DRM}^{(2)}$ (A)	$I_{BO}^{(3)}$ (mA)	$C_O^{(4)}$ (pF)	$V_{BO}$ to $V_T$ (nS)
LT230	195 – 265	184 – 276	15	1.0	50	2.0	25
LT800	680 – 920	640 - 960	15	1.0	50	2.0	25

#### Electrical Life:

Switching Cycles <sup>(5)</sup> ..... 400,000  
 Peak Discharge Current <sup>(5)</sup> ..... 400 A

#### Maximum Ratings:

Max Switching Frequency ..... 100 Hz  
 Storage Temperature  $T_{STG}$  ..... -40 - +150°C  
 Operating Temperature ..... -40 - +150°C

#### Notes:

- (1) Measured on recommended test circuit (fig 1.)
- (2) Measured @ 100 Volts DC
- (3) Current required for transition to on-state
- (4) Measured @ 1 MHz, zero Volt bias
- (5) Measured on recommended test circuit (fig 2.)

#### Definitions:

- $V_{BO}$  – Breakover Voltage
- $V_S$  – Switching Voltage
- $V_T @ 5A$  – Nominal Off-state Voltage at 5A
- $I_{DRM}$  – Off-state Current
- $I_{BO}$  – Nominal Breakover Current
- $C_O$  - Max Capacitance
- $V_{BO}$  to  $V_T$  – Max switching time from  $V_{BO}$  to  $V_T$

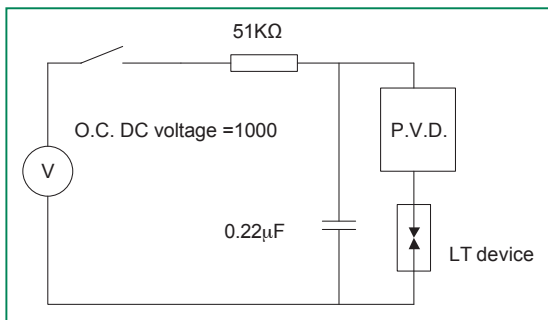

**Fig 1.** Recommended breakover voltage test circuit  
 (Discharge current = 10-20mA, sensitivity of Peak Voltage Detect = 10-30mA)

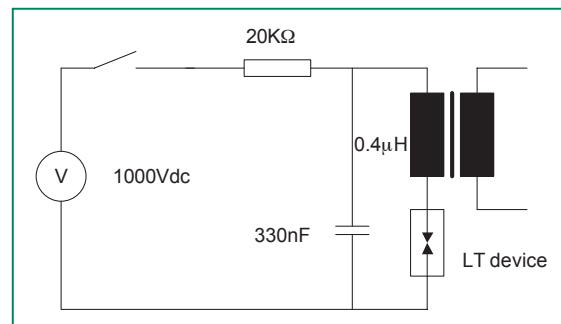

**Fig 2.** Recommended Life Circuit