



Chipsmall Limited consists of a professional team with an average of over 10 year of expertise in the distribution of electronic components. Based in Hongkong, we have already established firm and mutual-benefit business relationships with customers from,Europe,America and south Asia,supplying obsolete and hard-to-find components to meet their specific needs.

With the principle of “Quality Parts,Customers Priority,Honest Operation,and Considerate Service”,our business mainly focus on the distribution of electronic components. Line cards we deal with include Microchip,ALPS,ROHM,Xilinx,Pulse,ON,Everlight and Freescale. Main products comprise IC,Modules,Potentiometer,IC Socket,Relay,Connector.Our parts cover such applications as commercial,industrial, and automotives areas.

We are looking forward to setting up business relationship with you and hope to provide you with the best service and solution. Let us make a better world for our industry!



Contact us

Tel: +86-755-8981 8866 Fax: +86-755-8427 6832

Email & Skype: info@chipsmall.com Web: www.chipsmall.com

Address: A1208, Overseas Decoration Building, #122 Zhenhua RD., Futian, Shenzhen, China



Boost/SEPIC/Inverting DC/DC Converter with 65V Switch, Soft-Start and Synchronization

FEATURES

- 65V Power Switch
- Current Limit Options of 0.5A (LT8570) or 0.25A (LT8570-1)
- Adjustable Switching Frequency
- Single Feedback Resistor Sets V_{OUT}
- Synchronizable to External Clock
- High Gain \overline{SHDN} Pin Accepts Slowly Varying Input Signals
- Wide Input Voltage Range: 2.55V to 40V
- Low V_{CESAT} Switch
- Integrated Soft-Start Function
- Easily Configurable as a Boost, SEPIC, or Inverting Converter
- User Configurable Undervoltage Lockout (UVLO)
- Pin Compatible with LT3580 and LT8580
- Tiny Thermally Enhanced 8-Lead 3mm × 3mm DFN and 8-Lead MSOP Packages

APPLICATIONS

- VFD Bias Supplies
- TFT-LCD Bias Supplies
- GPS Receivers
- DSL Modems
- Local Power Supply

DESCRIPTION

The **LT[®]8570** and **LT8570-1** are PWM DC/DC converters. The LT8570 contains a 0.5A, 65V power switch, while the LT8570-1 contains a 0.25A, 65V power switch. The LT8570 and LT8570-1 can be configured as either a boost, SEPIC or inverting converter.

The LT8570/LT8570-1 have an adjustable oscillator, set by a resistor from the RT pin to ground. Additionally, the LT8570/LT8570-1 can be synchronized to an external clock. The switching frequency of the part may be free running or synchronized, and can be set between 200kHz and 1.5MHz.

The LT8570/LT8570-1 also feature innovative \overline{SHDN} pin circuitry that allows for slowly varying input signals and an adjustable undervoltage lockout function.

Additional features such as frequency foldback and soft-start are integrated. The LT8570/LT8570-1 are available in tiny thermally enhanced 3mm × 3mm 8-lead DFN and 8-lead MSOP packages.

LT, LT, LTC, LTM, Linear Technology and the Linear logo are registered trademarks and ThinSOT is a trademark of Linear Technology Corporation. All other trademarks are the property of their respective owners. Protected by U.S. Patents, including 7579816.

TYPICAL APPLICATION

1.5MHz, 5V to 12V Boost Converter

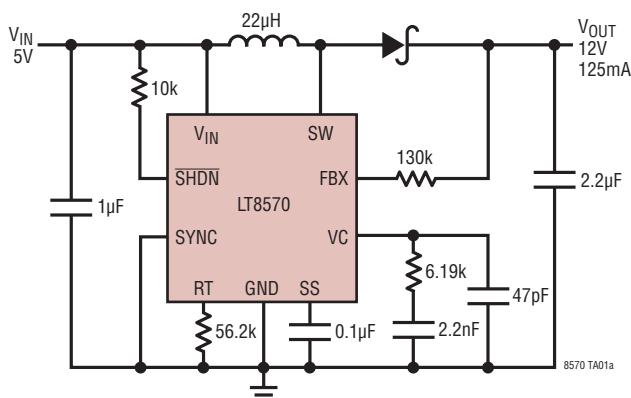

Efficiency and Power Loss

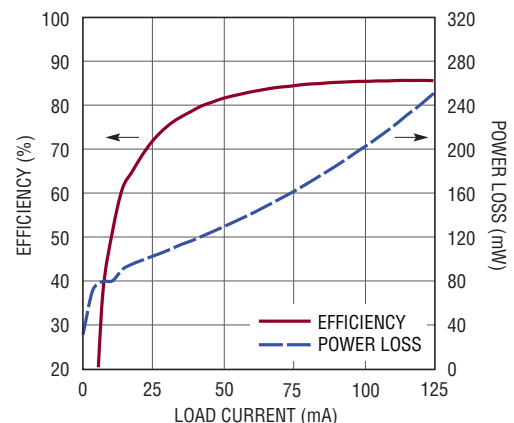

8570 TA01b

85701fa

LT8570/LT8570-1

ABSOLUTE MAXIMUM RATINGS (Note 1)

V_{IN} Voltage.....	-0.3V to 40V	SYNC Voltage.....	-0.3V to 5.5V
SW Voltage	-0.4V to 65V	Operating Junction Temperature Range	
RT Voltage	-0.3V to 5V	LT8570E, LT8570-1E (Notes 2, 5)	-40°C to 125°C
SS Voltage	-0.3V to 2.5V	LT8570I, LT8570-1I (Notes 2, 5)	-40°C to 125°C
FBX Voltage.....	5V	LT8570H, LT8570-1H (Notes 2, 5)	-40°C to 150°C
FBX Current.....	-1mA	Storage Temperature Range	-65°C to 150°C
VC Voltage	-0.3V to 2V	Lead Temperature (Soldering, 10 sec)	
SHDN Voltage	-0.3V to 40V	MS8E Package Only.....	300°C

PIN CONFIGURATION



ORDER INFORMATION <http://www.linear.com/product/LT8570#orderinfo>

LEAD FREE FINISH	TAPE AND REEL	PART MARKING*	PACKAGE DESCRIPTION	TEMPERATURE RANGE
LT8570EDD#PBF	LT8570EDD#TRPBF	LGRY	8-Lead (3mm x 3mm) Plastic DFN	-40°C to 125°C
LT8570IDD#PBF	LT8570IDD#TRPBF	LGRY	8-Lead (3mm x 3mm) Plastic DFN	-40°C to 125°C
LT8570HDD#PBF	LT8570HDD#TRPBF	LGRY	8-Lead (3mm x 3mm) Plastic DFN	-40°C to 150°C
LT8570EMS8E#PBF	LT8570EMS8E#TRPBF	LTGRZ	8-Lead Plastic MSOP	-40°C to 125°C
LT8570IMS8E#PBF	LT8570IMS8E#TRPBF	LTGRZ	8-Lead Plastic MSOP	-40°C to 125°C
LT8570HMS8E#PBF	LT8570HMS8E#TRPBF	LTGRZ	8-Lead Plastic MSOP	-40°C to 150°C
LT8570EDD-1#PBF	LT8570EDD-1#TRPBF	LGSB	8-Lead (3mm x 3mm) Plastic DFN	-40°C to 125°C
LT8570IDD-1#PBF	LT8570IDD-1#TRPBF	LGSB	8-Lead (3mm x 3mm) Plastic DFN	-40°C to 125°C
LT8570HDD-1#PBF	LT8570HDD-1#TRPBF	LGSB	8-Lead (3mm x 3mm) Plastic DFN	-40°C to 150°C
LT8570EMS8E-1#PBF	LT8570EMS8E-1#TRPBF	LTGSC	8-Lead Plastic MSOP	-40°C to 125°C
LT8570IMS8E-1#PBF	LT8570IMS8E-1#TRPBF	LTGSC	8-Lead Plastic MSOP	-40°C to 125°C
LT8570HMS8E-1#PBF	LT8570HMS8E-1#TRPBF	LTGSC	8-Lead Plastic MSOP	-40°C to 150°C

Consult LTC Marketing for parts specified with wider operating temperature ranges. *The temperature grade is identified by a label on the shipping container.

For more information on lead free part marking, go to: <http://www.linear.com/leadfree/>

For more information on tape and reel specifications, go to: <http://www.linear.com/tapeandree/>. Some packages are available in 500 unit reels through designated sales channels with #TRMPBF suffix.

ELECTRICAL CHARACTERISTICS The ● denotes the specifications which apply over the full operating temperature range, otherwise specifications are at $T_A = 25^\circ\text{C}$. $V_{IN} = 5\text{V}$, $V_{SHDN} = V_{IN}$ unless otherwise noted. (Note 2)

PARAMETER	CONDITIONS		MIN	TYP	MAX	UNITS
Operating Voltage Range	-40°C to 125°C	●	2.55		40	V
	-40°C to 150°C	●	2.9		40	V
Positive Feedback Voltage		●	1.185	1.204	1.220	V
Negative Feedback Voltage		●	-3	3	12	mV
Positive FBX Pin Bias Current	V_{FBX} = Positive Feedback Voltage, Current Into Pin	●	81	83.3	85	μA
Negative FBX Pin Bias Current	V_{FBX} = Negative Feedback Voltage, Current Out of Pin	●	81	83.3	86	μA
Error Amplifier Transconductance				200		μmhos
Error Amplifier Voltage Gain				60		V/V
Quiescent Current	$V_{SHDN} = 2.5\text{V}$, Not Switching			1.2	1.7	mA
Quiescent Current in Shutdown	$V_{SHDN} = 0\text{V}$			0	1	μA
Reference Line Regulation	$2.55\text{V} \leq V_{IN} \leq 40\text{V}$			0.01	0.05	%/V
Switching Frequency, f_{OSC}	$R_T = 56.2\text{k}$	●	1.23	1.5	1.77	MHz
	$R_T = 422\text{k}$	●	165	200	235	kHz
Switching Frequency in Foldback	Compared to Normal f_{OSC}			1/6		Ratio
Switching Frequency Set Range	SYNCing or Free Running	●	200		1500	kHz
SYNC High Level for Synchronization		●	1.3			V
SYNC Low Level for Synchronization		●			0.4	V
SYNC Clock Pulse Duty Cycle	$V_{SYNC} = 0\text{V}$ to 2V		35		65	%
Recommended Minimum SYNC Ratio f_{SYNC}/f_{OSC}				3/4		
Minimum Off-Time				100		ns
Minimum On-Time				100		ns
Switch Current Limit	Minimum Duty Cycle (Note 3), LT8570	●	0.6	0.75	1	A
	Maximum Duty Cycle (Notes 3, 4), LT8570, $f_{OSC} = 1.5\text{MHz}$	●	0.27	0.5	0.85	A
	Maximum Duty Cycle (Notes 3, 4), LT8570, $f_{OSC} = 200\text{kHz}$	●	0.15	0.4	0.8	A
	Minimum Duty Cycle (Note 3), LT8570-1	●	0.3	0.375	0.5	A
	Maximum Duty Cycle (Notes 3, 4), LT8570-1, $f_{OSC} = 1.5\text{MHz}$	●	0.15	0.25	0.43	A
	Maximum Duty Cycle (Notes 3, 4), LT8570-1, $f_{OSC} = 200\text{kHz}$	●	0.075	0.2	0.4	A
Switch V_{CESAT}	$I_{SW} = 0.4\text{A}$ (LT8570)			250		mV
	$I_{SW} = 0.2\text{A}$ (LT8570-1)			250		mV
Switch Leakage Current	$V_{SW} = 5\text{V}$			0.01	1	μA
Soft-Start Charging Current	$V_{SS} = 0.5\text{V}$	●	4	6	8	μA
$\overline{\text{SHDN}}$ Minimum Input Voltage High	Active Mode, $\overline{\text{SHDN}}$ Rising	●	1.23	1.31	1.4	V
	Active Mode, $\overline{\text{SHDN}}$ Falling	●	1.21	1.27	1.33	V
$\overline{\text{SHDN}}$ Minimum Input Voltage Hysteresis				40		mV
$\overline{\text{SHDN}}$ Input Voltage Low	Shutdown Mode	●			0.3	V
$\overline{\text{SHDN}}$ Pin Bias Current	$V_{SHDN} = 3\text{V}$		9	44	56	μA
	$V_{SHDN} = 1.3\text{V}$			12	15	μA
	$V_{SHDN} = 0\text{V}$			0	0.1	μA

Note 1: Stresses beyond those listed under Absolute Maximum Ratings may cause permanent damage to the device. Exposure to any Absolute Maximum Rating condition for extended periods may affect device reliability and lifetime.

Note 2: The LT8570E/LT8570-1E are guaranteed to meet performance specifications from 0°C to 125°C junction temperature. Specifications over the -40°C to 125°C operating junction temperature range are assured by design, characterization and correlation with statistical process controls. The LT8570I/LT8570-1I are guaranteed over the full -40°C to 125°C operating junction temperature range. The LT8570H/LT8570-1H are guaranteed over

the full -40°C to 150°C operating junction temperature range. Operating lifetime is derated at junction temperatures greater than 125°C .

Note 3: Current limit guaranteed by design and/or correlation to static test.

Note 4: Current limit measured at equivalent of listed switching frequency.

Note 5: This IC includes overtemperature protection that is intended to protect the device during momentary overload conditions. Junction temperature will exceed 150°C when overtemperature protection is active. Continuous operation above the specified maximum operating junction temperature may impair device reliability.

LT8570/LT8570-1

TYPICAL PERFORMANCE CHARACTERISTICS $T_A = 25^\circ\text{C}$, unless otherwise specified

Switch Current Limit vs Duty Cycle

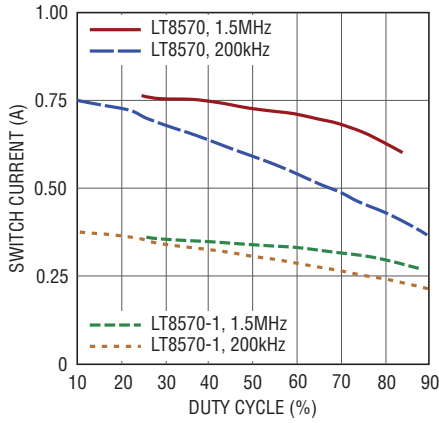

Switch Saturation Voltage

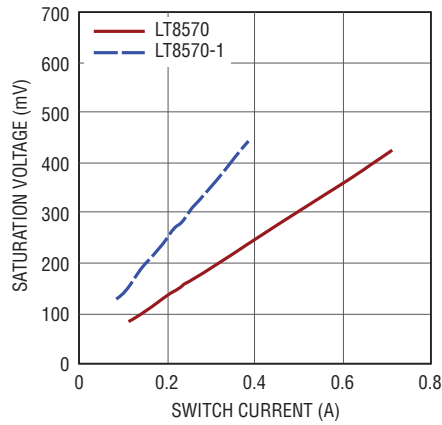

Maximum Switch Current vs SS

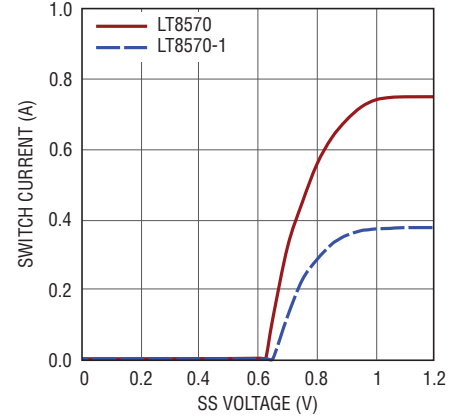

Switch Current Limit vs Temperature

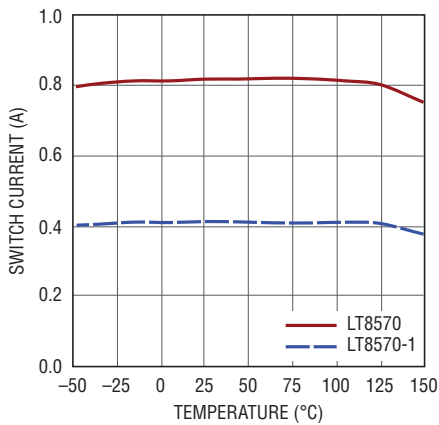

Positive and Negative Output Voltage Regulation

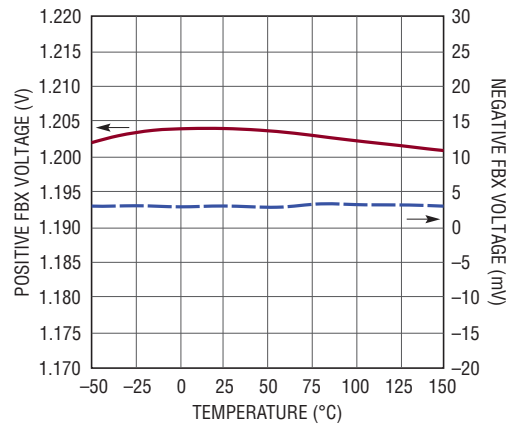

Positive and Negative FBX Current at Output Voltage Regulation

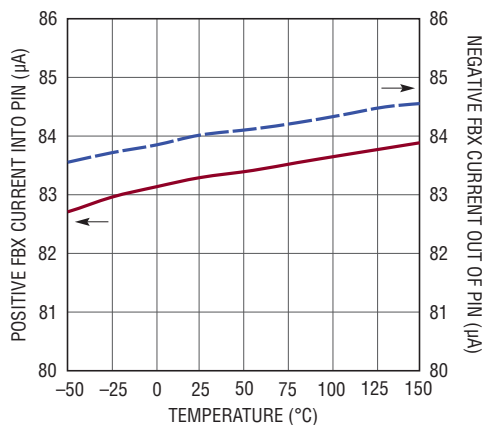

Oscillator Frequency

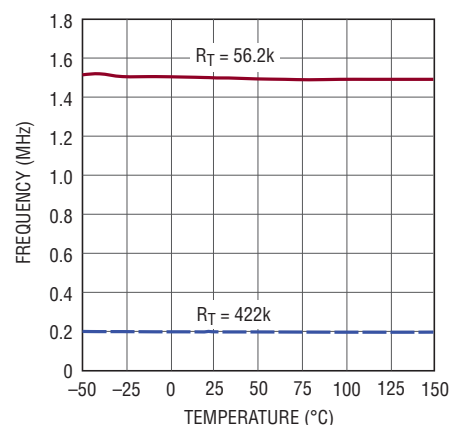

TYPICAL PERFORMANCE CHARACTERISTICS $T_A = 25^\circ\text{C}$, unless otherwise specified

Oscillator Frequency During Soft-Start

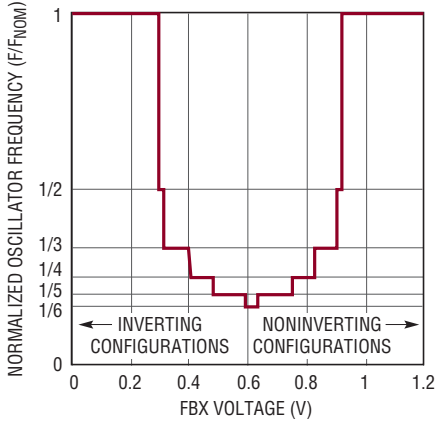

8570 G08

Internal UVLO

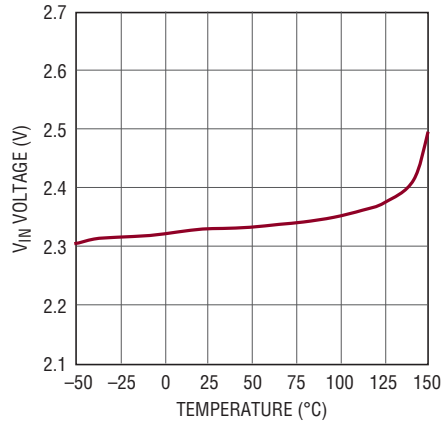

8570 G09

SHDN Pin Current

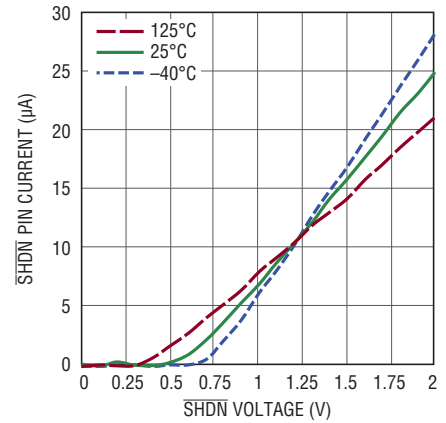

8570 G10

SHDN Pin Current

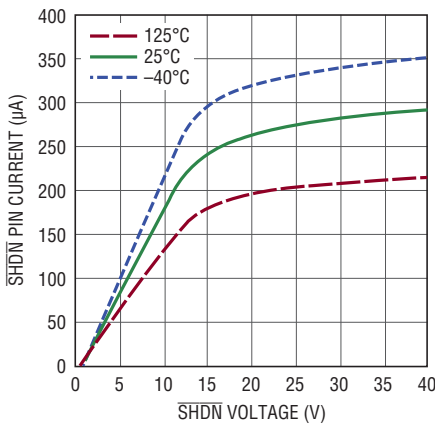

8570 G11

Active/Lockout Threshold

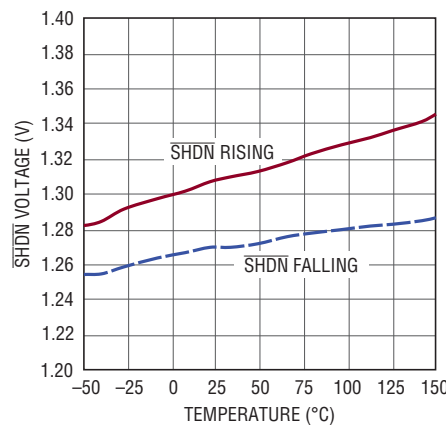

8570 G12

Minimum On-Time vs Temperature

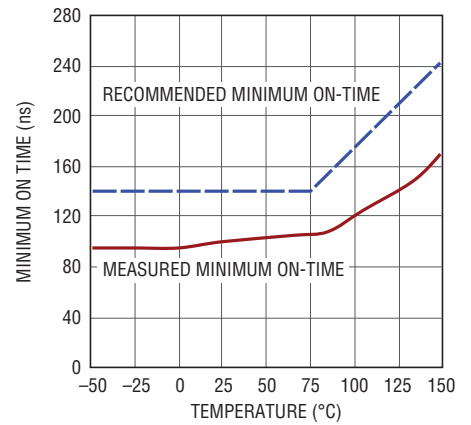

8570 G13

PIN FUNCTIONS

FBX (Pin 1): Positive and Negative Feedback Pin. For a noninverting or inverting converter, tie a resistor from the FBX pin to V_{OUT} according to the following equations:

$$R_{FBX} = \frac{(V_{OUT} - 1.204V)}{83.3\mu A}; \text{ Noninverting Converter}$$

$$R_{FBX} = \frac{(|V_{OUT}| + 3mV)}{83.3\mu A}; \text{ Inverting Converter}$$

VC (Pin 2): Error Amplifier Output Pin. Tie external compensation network to this pin.

V_{IN} (Pin 3): Input Supply Pin. Must be locally bypassed.

SW (Pin 4): Switch Pin. This is the collector of the internal NPN Power switch. Minimize the metal trace area connected to this pin to minimize EMI.

\overline{SHDN} (Pin 5): Shutdown Pin. In conjunction with the UVLO (undervoltage lockout) circuit, this pin is used to enable/disable the chip and restart the soft-start sequence. Drive below 1.21V to disable the chip. Drive above 1.40V to activate the chip and restart the soft-start sequence. Do not float this pin.

RT (Pin 6): Timing Resistor Pin. Adjusts the switching frequency. Place a resistor from this pin to ground to set the frequency to a fixed free running level. Do not float this pin.

SS (Pin 7): Soft-Start Pin. Place a soft-start capacitor here. Upon start-up, the SS pin will be charged by a (nominally) 280k resistor to about 2.1V.

SYNC (Pin 8): To synchronize the switching frequency to an outside clock, simply drive this pin with a clock. The high voltage level of the clock needs to exceed 1.3V, and the low level should be less 0.4V. Drive this pin to less than 0.4V to revert to the internal free-running clock. See the Applications Information section for more information.

GND (Exposed Pad Pin 9): Ground. Exposed pad must be soldered directly to local ground plane.

BLOCK DIAGRAM

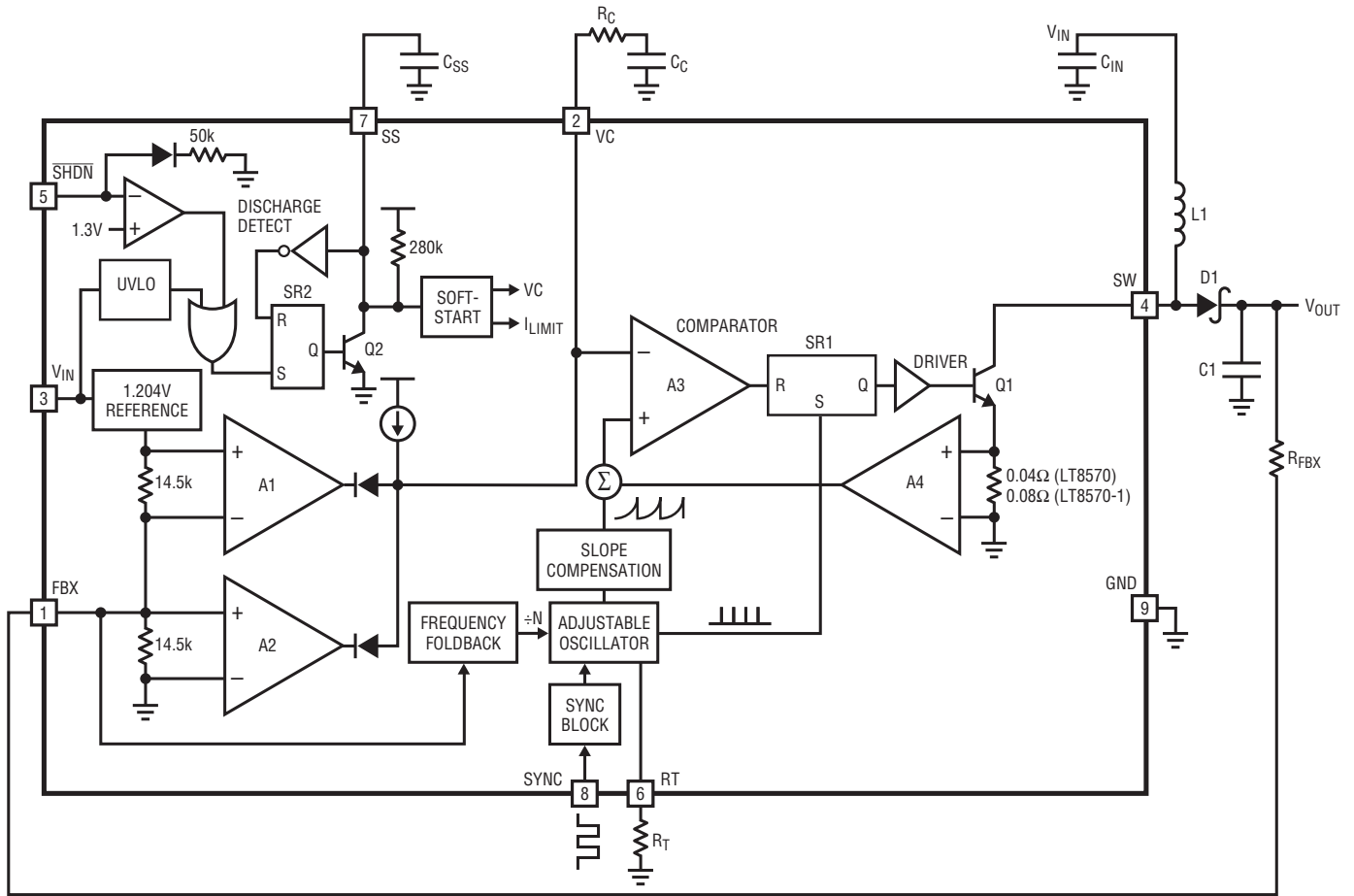

8570 BD

OPERATION

The LT8570/LT8570-1 use a constant-frequency, current mode control scheme to provide excellent line and load regulation. Refer to the Block Diagram for the following description of the part's operation. At the start of each oscillator cycle, the SR latch (SR1) is set, which turns on the power switch, Q1. The switch current flows through the internal current sense resistor, generating a voltage proportional to the switch current. This voltage (amplified by A4) is added to a stabilizing ramp and the resulting sum is fed into the positive terminal of the PWM comparator A3. When this voltage exceeds the level at the negative input of A3, the SR latch is reset, turning off the power switch. The level at the negative input of A3 (VC pin) is set by the error amplifier A1 (or A2) and is simply an amplified version of the difference between the feedback voltage (FBX pin) and the reference voltage (1.204V or 3mV, depending on the configuration). In this manner, the error amplifier sets the correct peak current level to keep the output in regulation.

The LT8570/LT8570-1 have an FBX pin architecture that can be used for either noninverting or inverting configurations. When configured as a noninverting converter, the FBX pin is pulled up to the internal bias voltage of 1.204V by the R_{FBX} resistor connected from V_{OUT} to FBX. Amplifier A2 becomes inactive and amplifier A1 performs the inverting amplification from FBX to VC. When the LT8570/LT8570-1 are in an inverting configuration, the FBX pin is pulled

down to 3mV by the R_{FBX} resistor connected from V_{OUT} to FBX. Amplifier A1 becomes inactive and amplifier A2 performs the noninverting amplification from FBX to VC.

SEPIC Topology

As shown in Figure 1, the LT8570/LT8570-1 can be configured as a SEPIC (single-ended primary inductance converter). This topology allows for the input to be higher, equal, or lower than the desired output voltage. Output disconnect is inherently built into the SEPIC topology, meaning no DC path exists between the input and output. This is useful for applications requiring the output to be disconnected from the input source when the circuit is in shutdown.

Inverting Topology

The LT8570/LT8570-1 can also work in a dual inductor inverting topology, as shown in Figure 2. The part's unique feedback pin allows for the inverting topology to be built by simply changing the connection of external components. This solution results in very low output voltage ripple due to the inductor L2 in series with the output. Abrupt changes in output capacitor current are eliminated because the output inductor delivers current to the output during both the off-time and the on-time of the LT8570/LT8570-1 switch.

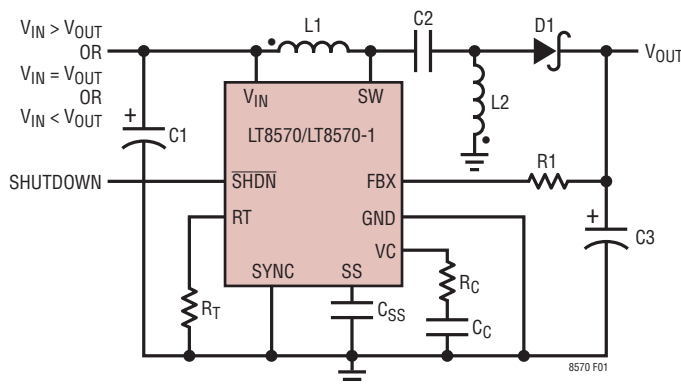

Figure 1. SEPIC Topology Allows for the Input to Span the Output Voltage. Coupled or Uncoupled Inductors Can Be Used. Follow Noted Phasing if Coupled

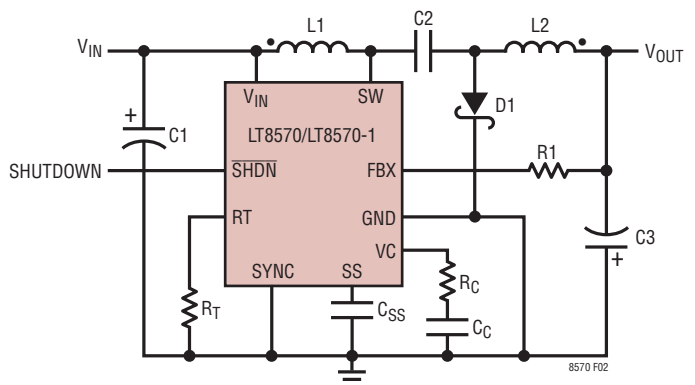

Figure 2. Dual Inductor Inverting Topology Results in Low Output Ripple. Coupled or Uncoupled Inductors Can Be Used. Follow Noted Phasing if Coupled

OPERATION

Start-Up Operation

Several functions are provided to enable a very clean start-up for the LT8570/LT8570-1.

- First, the $\overline{\text{SHDN}}$ pin voltage is monitored by an internal voltage reference to give a precise turn-on voltage level. An external resistor (or resistor divider) can be connected from the input power supply to the $\overline{\text{SHDN}}$ pin to provide a user-programmable undervoltage lockout function.
- Second, the soft-start circuitry provides for a gradual ramp-up of the switch current. When the part is brought out of shutdown, the external SS capacitor is first discharged (providing protection against $\overline{\text{SHDN}}$ pin glitches and slow ramping), then an integrated 280k resistor pulls the SS pin up to $\sim 2.1\text{V}$. By connecting an external capacitor to the SS pin, the voltage ramp rate on the pin can be set. Typical values for the soft-start capacitor range from 100nF to 1 μF .
- Finally, the frequency foldback circuit reduces the switching frequency when the FBX pin is in a nominal range of 300mV to 920mV. This feature reduces the minimum

duty cycle that the part can achieve thus allowing better control of the switch current during start-up. When the FBX voltage is pulled outside of this range, the switching frequency returns to normal.

Current Limit and Thermal Shutdown Operation

The LT8570/LT8570-1 have a current limit circuit not shown in the Block Diagram. The switch current is constantly monitored and not allowed to exceed the maximum switch current at a given duty cycle (see the Electrical Characteristics table). If the switch current reaches this value, the SR latch (SR1) is reset regardless of the state of the comparator (A1/A2). Also, not shown in the Block Diagram is the thermal shutdown circuit. If the temperature of the part exceeds approximately 165°C, the SR2 latch is set regardless of the state of the amplifier (A1/A2). When the part temperature falls below approximately 160°C, a full soft-start cycle will then be initiated. The current limit and thermal shutdown circuits protect the power switch as well as the external components connected to the LT8570/LT8570-1.

APPLICATIONS INFORMATION

Setting Output Voltage

The output voltage is set by connecting a resistor (R_{FBX}) from V_{OUT} to the FBX pin. R_{FBX} is determined from the following equation:

$$R_{FBX} = \frac{|V_{OUT} - V_{FBX}|}{83.3\mu A}$$

where V_{FBX} is 1.204V (typical) for noninverting topologies (i.e., boost and SEPIC regulators) and 3mV (typical) for inverting topologies (see the Electrical Characteristics).

Power Switch Duty Cycle

In order to maintain loop stability and deliver adequate current to the load, the power NPN (Q1 in the Block Diagram) cannot remain “on” for 100% of each clock cycle. The maximum allowable duty cycle is given by:

$$DC_{MAX} = \frac{(T_P - \text{Min Off Time})}{T_P} \cdot 100\%$$

where T_P is the clock period and Min Off Time (found in the Electrical Characteristics) is typically 100ns.

The application should be designed so that the operating duty cycle does not exceed DC_{MAX} .

The minimum allowable duty cycle is given by:

$$DC_{MIN} = \frac{\text{Min On Time}}{T_P} \cdot 100\%$$

where T_P is the clock period and Min On-Time is as shown in the Typical Performance Characteristics.

The application should be designed so that the operating duty cycle is at least DC_{MIN} .

Duty cycle equations for several common topologies are given below, where V_D is the diode forward voltage drop and V_{CESAT} is typically 250mV at 0.4A for the LT8570 and 250mV at 0.2A for the LT8570-1.

For the boost topology:

$$DC \cong \frac{V_{OUT} - V_{IN} + V_D}{V_{OUT} + V_D - V_{CESAT}}$$

For the SEPIC or dual inductor inverting topology (see Figure 1 and Figure 2):

$$DC \cong \frac{V_D + |V_{OUT}|}{V_{IN} + |V_{OUT}| + V_D - V_{CESAT}}$$

The LT8570/LT8570-1 can be used in configurations where the duty cycle is higher than DC_{MAX} , but it must be operated in the discontinuous conduction mode so that the effective duty cycle is reduced.

Inductor Selection

General Guidelines: The high frequency operation of the LT8570/LT8570-1 allows for the use of small surface mount inductors. For high efficiency, choose inductors with high frequency core material, such as ferrite, to reduce core losses. To improve efficiency, choose inductors with more volume for a given inductance. The inductor should have low DCR (copper wire resistance) to reduce I^2R losses, and must be able to handle the peak inductor current without saturating. Note that in some applications, the current handling requirements of the inductor can be lower, such as in the SEPIC topology, where each inductor only carries a fraction of the total switch current. Multilayer or chip inductors usually do not have enough core area to support peak inductor currents in the 0.25A to 1A range. To minimize radiated noise, use a toroidal or shielded inductor. Note that the inductance of shielded types will drop more as current increases, and will saturate more easily. See Table 1 for a list of inductor manufacturers. Thorough lab evaluation is recommended to verify that the following guidelines properly suit the final application.

Table 1. Inductor Manufacturers

Coilcraft	LPS5030, MSS7341, LPS4018, LPD6235 and LPD5030 Series	www.coilcraft.com
Coiltronics	DR, DRQ, SD and SDQ Series	www.coiltronics.com
Sumida	CDRH8D58/LD, CDRH64B, and CDRH70D430MN Series	www.sumida.com
Würth	WE-PD, WE-DD, WE-TPC, WE-LHMI and WE-LQS Series	www.we-online.com

Minimum Inductance: Although there can be a trade-off with efficiency, it is often desirable to minimize board space by choosing smaller inductors. When choosing an inductor, there are two conditions that limit the minimum inductance: (1) providing adequate load current,

85701fa

APPLICATIONS INFORMATION

and (2) avoiding subharmonic oscillation. Choose an inductance that is high enough to meet both of these requirements.

Adequate Load Current: Small value inductors result in increased ripple currents and thus, due to the limited peak switch current, decrease the average current that can be provided to a load (I_{OUT}). In order to provide adequate load current, L should be at least:

$$L_{BOOST} > \frac{DC \cdot V_{IN}}{2 \cdot f \cdot \left(I_{LIM} - \frac{|V_{OUT}| \cdot I_{OUT}}{V_{IN} \cdot \eta} \right)}$$

for boost, topologies, or:

$$L_{DUAL} > \frac{DC \cdot V_{IN}}{2 \cdot f \cdot \left(I_{LIM} - \frac{|V_{OUT}| \cdot I_{OUT}}{V_{IN} \cdot \eta} - I_{OUT} \right)}$$

for the SEPIC and inverting topologies.

where:

$L_{BOOST} = L1$ for boost topologies (see Figure 15)

$L_{DUAL} = L1 = L2$ for coupled dual inductor topologies (see Figure 16 and Figure 17)

$L_{DUAL} = L1 || L2$ for uncoupled dual inductor topologies (see Figure 16 and Figure 17)

DC = switch duty cycle (see previous section)

I_{LIM} = switch current limit, typically about 0.6A for LT8570 and 0.3A for LT8570-1 at 50% duty cycle (see the Typical Performance Characteristics section).

η = power conversion efficiency (typically 85% for boost and 83% for dual inductor topologies at high currents).

f = switching frequency

I_{OUT} = maximum load current

Negative values of L indicate that the output load current I_{OUT} exceeds the switch current limit capability of the LT8570/LT8570-1.

Avoiding Subharmonic Oscillations: The LT8570/LT8570-1's internal slope compensation circuit can prevent subharmonic oscillations that can occur when the duty cycle

is greater than 50%, provided that the inductance exceeds a minimum value. In applications that operate with duty cycles greater than 50%, the inductance must be at least:

$$L_{MIN} > \frac{V_{IN}}{k_{SC} \cdot (DC - 300ns \cdot f) \cdot f} \cdot \frac{2 \cdot DC - 1}{1 - DC}$$

$L_{MIN} = L1$ for boost topologies (see Figure 15)

$L_{MIN} = L1 = L2$ for coupled dual inductor topologies (see Figure 16 and Figure 17)

$L_{MIN} = L1 || L2$ for uncoupled dual inductor topologies (see Figure 16 and Figure 17)

$k_{SC} = 0.6$ for LT8570 and 0.3 for LT8570-1

Maximum Inductance: Excessive inductance can reduce current ripple to levels that are difficult for the current comparator (A3 in the Block Diagram) to cleanly discriminate, thus causing duty cycle jitter and/or poor regulation. The maximum inductance can be calculated by:

$$L_{MAX} = \frac{V_{IN} - V_{CESAT}}{I_{MIN-RIPPLE}} \cdot \frac{DC}{f}$$

where

$L_{MIN} = L1$ for boost topologies (see Figure 15)

$L_{MIN} = L1 = L2$ for coupled dual inductor topologies (see Figure 16 and Figure 17)

$L_{MIN} = L1 || L2$ for uncoupled dual inductor topologies (see Figure 16 and Figure 17)

$I_{MIN-RIPPLE}$ = typically 40mA for LT8570 and 20mA for LT8570-1

Current Rating: Finally, the inductor(s) must have a rating greater than its peak operating current to prevent inductor saturation resulting in efficiency loss. In steady state, the peak input inductor current (continuous conduction mode only) is given by:

$$I_{L1-PEAK} = \frac{|V_{OUT}| \cdot I_{OUT}}{V_{IN} \cdot \eta} + \frac{V_{IN} \cdot DC}{2 \cdot L1 \cdot f}$$

for the boost, SEPIC and dual inductor inverting topologies.

APPLICATIONS INFORMATION

For dual inductor topologies, the peak output inductor current is given by:

$$I_{L2-PEAK} = I_{OUT} + \frac{|V_{OUT}| \cdot (1 - DC)}{2 \cdot L \cdot f}$$

For the dual inductor topologies, the total peak current is:

$$I_{L-PEAK} = I_{OUT} \left(1 + \frac{|V_{OUT}|}{\eta \cdot V_{IN}} \right) + \frac{V_{IN} \cdot DC}{2 \cdot L \cdot f}$$

Note: Peak inductor current is limited by the switch current limit. Refer to the Electrical Characteristics table and to the Switch Current Limit vs Duty Cycle plot in the Typical Performance Characteristics.

Capacitor Selection

Low ESR (equivalent series resistance) capacitors should be used at the output to minimize the output ripple voltage. Multilayer ceramic capacitors are an excellent choice, as they have an extremely low ESR and are available in very small packages. X5R or X7R dielectrics are preferred, as these materials retain their capacitance over wider voltage and temperature ranges. For LT8570, a 0.22 μ F to 4.7 μ F and for LT8570-1, a 0.1 μ F to 2.2 μ F output capacitor is sufficient for most applications. Always use a capacitor with a sufficient voltage rating. Although many ceramic capacitors have greatly reduced capacitance at the desired output voltage, ceramic capacitors with larger case sizes are less sensitive to applied voltage. Solid tantalum or OS-CON capacitors can be used, but they will occupy more board area than a ceramic and will have a higher ESR with greater output ripple.

Ceramic capacitors also make a good choice for the input decoupling capacitor, which should be placed as closely as possible to the V_{IN} pin of the LT8570/LT8570-1 as well as to the inductor connected to the input of the power path. If it is not possible to optimally place a single input capacitor, then use one at the V_{IN} pin of the chip (C_{VIN}) and one at the V_{IN} side of the inductor (C_{PWR}). See equations in Table 4, Table 5 and Table 6 for sizing information. For LT8570, a 0.47 μ F to 1 μ F and for LT8570-1, a 0.22 μ F to 0.47 μ F input capacitor is sufficient for most applications.

Table 2 shows a list of several ceramic capacitor manufacturers. Consult the manufacturers for detailed information on their entire selection of ceramic parts.

Table 2. Ceramic Capacitor Manufacturers

Kemet	www.kemet.com
Murata	www.murata.com
Taiyo Yuden	www.t-yuden.com
TDK	www.tdk.com

Compensation—Adjustment

To compensate the feedback loop of the LT8570/LT8570-1, a series resistor-capacitor network in parallel with a single capacitor should be connected from the VC pin to GND. For most applications, the series capacitor should be in the range of 470pF to 2.2nF with 1nF being a good starting value. The parallel capacitor should range in value from 10pF to 100pF with 47pF a good starting value. The compensation resistor, R_C , is usually in the range of 5k to 50k. A good technique to compensate a new application is to use a 100k Ω potentiometer in place of series resistor R_C . With the series capacitor and parallel capacitor at 1nF and 47pF respectively, adjust the potentiometer while observing the transient response and the optimum value for R_C can be found. Figure 3 (3a to 3c) illustrates this process for the circuit of Figure 4 with a load current stepped between 30mA and 90mA. Figure 3a shows the transient response with R_C equal to 1.04k. The phase margin is poor, as evidenced by the excessive ringing in the output voltage and inductor current. In Figure 3b, the value of R_C is increased to 2.09k, which results in a more damped response. Figure 3c shows the results when R_C is increased further to 6.19k. The transient response is nicely damped and the compensation procedure is complete.

Compensation—Theory

Like all other current mode switching regulators, the LT8570/LT8570-1 need to be compensated for stable and efficient operation. Two feedback loops are used in the LT8570/LT8570-1 — a fast current loop which does not require compensation, and a slower voltage loop which does. Standard bode plot analysis can be used to understand and adjust the voltage feedback loop.

APPLICATIONS INFORMATION

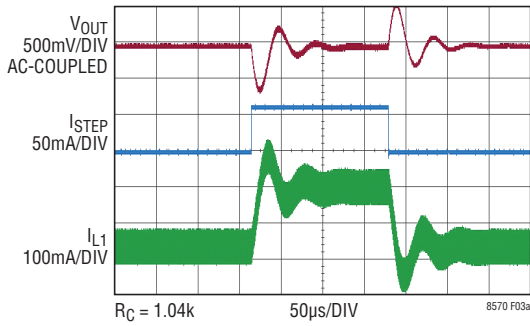

(3a) Transient Response Shows Excessive Ringing

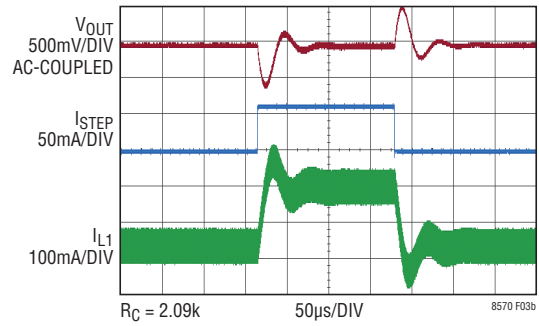

(3b) Transient Response Is Better

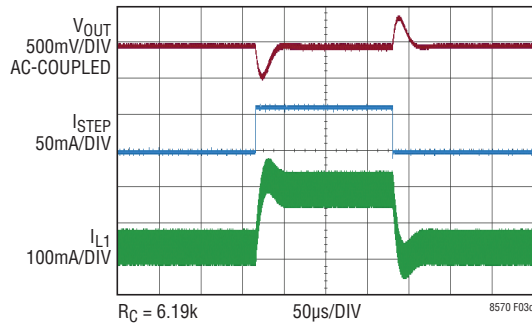

(3c) Transient Response Is Well Damped

Figure 3. Transient Response

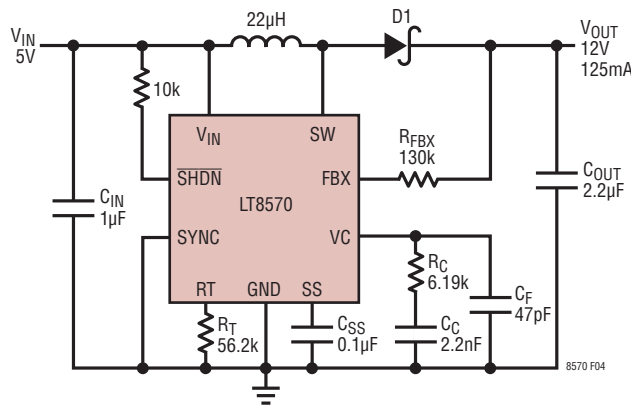
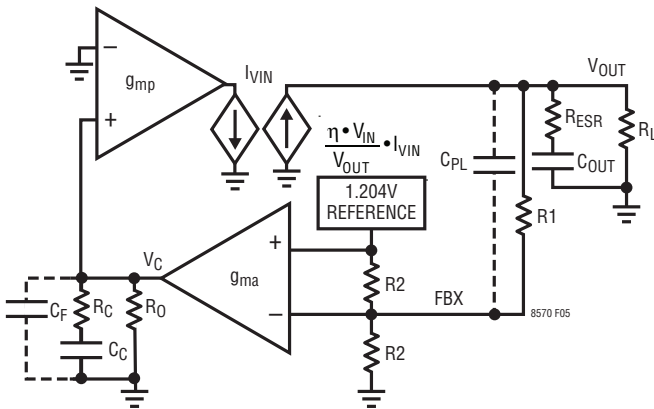

Figure 4. 1.5MHz, 5V to 12V Boost Converter

APPLICATIONS INFORMATION

As with any feedback loop, identifying the gain and phase contribution of the various elements in the loop is critical. Figure 5 shows the key equivalent elements of a boost converter. Because of the fast current control loop, the power stage of the IC, inductor and diode have been replaced by a combination of the equivalent transconductance amplifier g_{mp} and the current controlled current source which converts I_{VIN} to $(\eta V_{IN}/V_{OUT}) \cdot I_{VIN}$. g_{mp} acts as a current source where the peak input current, I_{VIN} , is proportional to the VC voltage. η is the efficiency of the switching regulator, and is typically about 85%.

Note that the maximum output currents of g_{mp} and g_{ma} are finite. The limits for g_{mp} are in the Electrical Characteristics section (switch current limit), and g_{ma} is nominally limited to about $+15\mu A$ and $-17\mu A$.



- C_C : COMPENSATION CAPACITOR
- C_{OUT} : OUTPUT CAPACITOR
- C_{PL} : PHASE LEAD CAPACITOR
- C_F : HIGH FREQUENCY FILTER CAPACITOR
- g_{ma} : TRANSCONDUCTANCE AMPLIFIER INSIDE IC
- g_{mp} : POWER STAGE TRANSCONDUCTANCE AMPLIFIER
- R_C : COMPENSATION RESISTOR
- R_L : OUTPUT RESISTANCE DEFINED AS V_{OUT} DIVIDED BY $I_{LOAD(MAX)}$
- R_O : OUTPUT RESISTANCE OF g_{ma}
- R_1, R_2 : FEEDBACK RESISTOR DIVIDER NETWORK
- R_{ESR} : OUTPUT CAPACITOR ESR
- η : CONVERTER EFFICIENCY (~85% AT HIGHER CURRENTS)

Figure 5. Boost Converter Equivalent Model

From Figure 5, the DC gain, poles and zeros can be calculated as follows:

DC Gain:

(Breaking Loop at FBX Pin)

$$A_{DC} = A_{OL}(0) = \frac{\partial V_C}{\partial V_{FBX}} \cdot \frac{\partial I_{VIN}}{\partial V_C} \cdot \frac{\partial V_{OUT}}{\partial I_{VIN}} \cdot \frac{\partial V_{FBX}}{\partial V_{OUT}} = (g_{ma} \cdot R_O) \cdot g_{mp} \cdot \left(\eta \cdot \frac{V_{IN}}{V_{OUT}} \cdot \frac{R_L}{2} \right) \cdot \frac{0.5R_2}{R_1 + 0.5R_2}$$

$$\text{Output Pole: } P1 = \frac{2}{2 \cdot \pi \cdot R_L \cdot C_{OUT}}$$

$$\text{Error Amp Pole: } P2 = \frac{1}{2 \cdot \pi \cdot [R_O + R_C] \cdot C_C}$$

$$\text{Error Amp Zero: } Z1 = \frac{1}{2 \cdot \pi \cdot R_C \cdot C_C}$$

$$\text{ESR Zero: } Z2 = \frac{1}{2 \cdot \pi \cdot R_{ESR} \cdot C_{OUT}}$$

$$\text{RHP Zero: } Z3 = \frac{V_{IN}^2 \cdot R_L}{2 \cdot \pi \cdot V_{OUT}^2 \cdot L}$$

$$\text{High Frequency Pole: } P3 > \frac{f_S}{3}$$

$$\text{Phase Lead Zero: } Z4 = \frac{1}{2 \cdot \pi \cdot R_1 \cdot C_{PL}}$$

$$\text{Phase Lead Pole: } P4 = \frac{1}{2 \cdot \pi \cdot \frac{R_1 \cdot R_2}{R_1 + \frac{R_2}{2}} \cdot C_{PL}}$$

Error Amp Filter Pole:

$$P5 = \frac{1}{2 \cdot \pi \cdot \frac{R_C \cdot R_O}{R_C + R_O} \cdot C_F}, C_F < \frac{C_C}{10}$$

APPLICATIONS INFORMATION

The current mode zero (Z3) is a right-half plane zero which can be an issue in feedback control design, but is manageable with proper external component selection.

Using the circuit in Figure 4 as an example, Table 3 shows the parameters used to generate the bode plot shown in Figure 6.

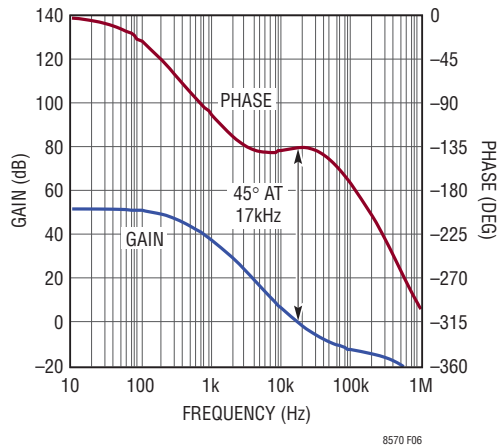

Figure 6. Bode Plot for Example Boost Converter

Table 3. Bode Plot Parameters

PARAMETER	VALUE	UNITS	COMMENT
R_L	96	Ω	Application Specific
C_{OUT}	2.2	μF	Application Specific
R_{ESR}	10	$m\Omega$	Application Specific
R_O	300	$k\Omega$	Not Adjustable
C_C	2200	pF	Adjustable
C_F	47	pF	Optional/Adjustable
C_{PL}	0	pF	Optional/Adjustable
R_C	6.19	$k\Omega$	Adjustable
R_1	130	$k\Omega$	Adjustable
R_2	14.5	$k\Omega$	Not Adjustable
V_{OUT}	12	V	Application Specific
V_{IN}	5	V	Application Specific
g_{ma}	200	μmho	Not Adjustable
g_{mp}	7	mho	Not Adjustable
L	22	μH	Application Specific
f_S	1.5	MHz	Adjustable

In Figure 6, the phase is -135° when the gain reaches 0dB giving a phase margin of 45° . The crossover frequency is 17kHz, which is more than three times lower than the frequency of the RHP zero to achieve adequate phase margin.

Diode Selection

Schottky diodes, with their low forward-voltage drops and fast switching speeds, are recommended for use with the LT8570/LT8570-1. For applications where V_R (see Tables 4, 5 and 6) $< 40V$, the Diodes, Inc. PD3S140 is a good choice. Where $V_R > 40V$, the Diodes Inc. DFLS1100 works well. These diodes are rated to handle an average forward current of 1A.

Oscillator

The operating frequency of the LT8570/LT8570-1 can be set by the internal free-running oscillator. When the SYNC pin is driven low ($< 0.4V$), the frequency of operation is set by a resistor from R_T to ground. An internally trimmed timing capacitor resides inside the IC. The oscillator frequency is calculated using the following formula:

$$f_{OSC} = \frac{85.5}{(R_T + 1)}$$

where f_{OSC} is in MHz and R_T is in $k\Omega$. Conversely, R_T (in $k\Omega$) can be calculated from the desired frequency (in MHz) using:

$$R_T = \frac{85.5}{f_{OSC}} - 1$$

Clock Synchronization

The operating frequency of the LT8570/LT8570-1 can be synchronized to an external clock source. To synchronize to the external source, simply provide a digital clock signal into the SYNC pin. The LT8570/LT8570-1 will operate at the SYNC clock frequency. The LT8570/LT8570-1 will revert to the internal free-running oscillator clock after SYNC is driven low for a few free-running clock periods.

APPLICATIONS INFORMATION

Driving SYNC high for an extended period of time effectively stops the operating clock and prevents latch SR1 from becoming set (see the Block Diagram). As a result, the switching operation of the LT8570/LT8570-1 will stop.

The duty cycle of the SYNC signal must be between 35% and 65% for proper operation. Also, the frequency of the SYNC signal must meet the following two criteria:

- (1) SYNC may not toggle outside the frequency range of 200kHz to 1.5MHz unless it is stopped low to enable the free-running oscillator.
- (2) The SYNC frequency can always be higher than the free-running oscillator frequency, f_{OSC} , but should not be less than 25% below f_{OSC} .

Operating Frequency Selection

There are several considerations in selecting the operating frequency of the converter. The first is staying clear of sensitive frequency bands, which cannot tolerate any spectral noise. For example, in products incorporating RF communications, the 455kHz IF frequency is sensitive to any noise, therefore switching above 600kHz is desired. Some communications have sensitivity to 1.1MHz, and in that case, a 1.5MHz switching converter frequency may be employed. The second consideration is the physical size of the converter. As the operating frequency goes up, the inductor and filter capacitors go down in value and size. The trade-off is efficiency, since the switching losses due to NPN base charge (see Thermal Calculations), Schottky diode charge, and other capacitive loss terms increase proportionally with frequency.

Soft-Start

The LT8570/LT8570-1 contain a soft-start circuit to limit peak switch currents during start-up. High start-up current is inherent in switching regulators in general since the feedback loop is saturated due to V_{OUT} being far from its final value. The regulator tries to charge the output capacitor as quickly as possible, which results in large peak currents.

The start-up current can be limited by connecting an external capacitor (typically 100nF to 1 μ F) to the SS pin.

This capacitor is slowly charged to ~2.1V by an internal 280k resistor once the part is activated. SS pin voltages below ~1.1V reduce the internal current limit. Thus, the gradual ramping of the SS voltage also gradually increases the current limit as the capacitor charges. This, in turn, allows the output capacitor to charge gradually toward its final value while limiting the start-up current.

In the event of a commanded shutdown or lockout (\overline{SHDN} pin), internal undervoltage lockout (UVLO) or a thermal lockout, the soft-start capacitor is automatically discharged to ~200mV before charging resumes, thus assuring that the soft-start occurs after every reactivation of the chip.

Shutdown

The \overline{SHDN} pin is used to enable or disable the chip. For most applications, \overline{SHDN} can be driven by a digital logic source. Voltages above 1.4V enable normal active operation. Voltages below 300mV will shutdown the chip, resulting in extremely low quiescent current.

While the \overline{SHDN} voltage transitions through the lockout voltage range (0.3V to 1.21V) the power switch is disabled and the SR2 latch is set (see the Block Diagram). This causes the soft-start capacitor to begin discharging, which continues until the capacitor is discharged and active operation is enabled. Although the power switch is disabled, \overline{SHDN} voltages in the lockout range do not necessarily reduce quiescent current until the \overline{SHDN} voltage is near or below the shutdown threshold.

Also note that \overline{SHDN} can be driven above V_{IN} or V_{OUT} as long as the \overline{SHDN} voltage is limited to less than 40V.

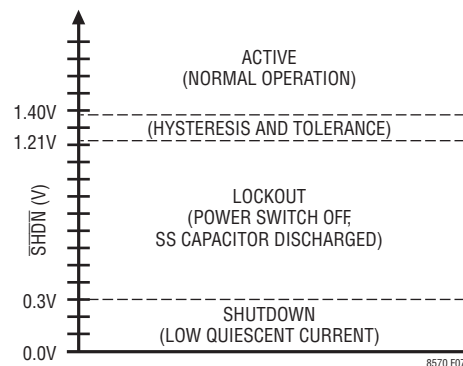

Figure 7. Chip States vs \overline{SHDN} Voltage

APPLICATIONS INFORMATION

Configurable Undervoltage Lockout

Figure 8 shows how to configure an undervoltage lockout (UVLO) for the LT8570/LT8570-1. Typically, UVLO is used in situations where the input supply is current-limited, has a relatively high source resistance, or ramps up/down slowly. A switching regulator draws constant power from the source, so source current increases as source voltage drops. This looks like a negative resistance load to the source and can cause the source to current-limit or latch low under low source voltage conditions. UVLO prevents the regulator from operating at source voltages where these problems might occur.

The shutdown pin comparator has voltage hysteresis with typical thresholds of 1.31V (rising) and 1.27V (falling). Resistor R_{UVLO2} is optional. R_{UVLO2} can be included to reduce the overall UVLO voltage variation caused by variations in $\overline{\text{SHDN}}$ pin current (see the Electrical Characteristics). A good choice for R_{UVLO2} is $\leq 10\text{k} \pm 1\%$. After choosing a value for R_{UVLO2} , R_{UVLO1} can be determined from either of the following:

$$R_{UVLO1} = \frac{V_{IN}^+ - 1.31\text{V}}{\left(\frac{1.31\text{V}}{R_{UVLO2}}\right) + 12\mu\text{A}}$$

or

$$R_{UVLO1} = \frac{V_{IN}^- - 1.27\text{V}}{\left(\frac{1.27\text{V}}{R_{UVLO2}}\right) + 12\mu\text{A}}$$

where V_{IN}^+ and V_{IN}^- are the V_{IN} voltages when rising or falling, respectively.

For example, to disable the LT8570/LT8570-1 for V_{IN} voltages below 3.5V using the single resistor configuration, choose:

$$R_{UVLO1} = \frac{3.5\text{V} - 1.27\text{V}}{\left(\frac{1.27\text{V}}{\infty}\right) + 12\mu\text{A}} = 187\text{k}$$

To activate the LT8570/LT8570-1 for V_{IN} voltages greater than 4.5V using the double resistor configuration, choose $R_{UVLO2} = 10\text{k}$ and:

$$R_{UVLO1} = \frac{4.5\text{V} - 1.31\text{V}}{\left(\frac{1.31\text{V}}{10\text{k}}\right) + 12\mu\text{A}} = 22.1\text{k}$$

Internal Undervoltage Lockout

The LT8570/LT8570-1 monitor the V_{IN} supply voltage in case V_{IN} drops below a minimum operating level (typically about 2.35V). When V_{IN} is detected low, the power switch is deactivated, and while sufficient V_{IN} voltage persists, the soft-start capacitor is discharged. After V_{IN} is detected high, the power switch will be reactivated and the soft-start capacitor will begin charging.

Thermal Considerations

For the LT8570/LT8570-1 to deliver their full output power, it is imperative that a good thermal path be provided to dissipate the heat generated within the package. This is accomplished by taking advantage of the thermal pad on the underside of the IC. It is recommended that multiple vias in the printed circuit board be used to conduct heat away from the IC and into a copper plane with as much area as possible.

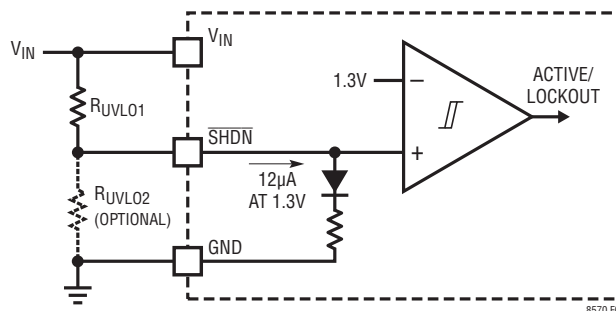

Figure 8. Configurable UVLO

APPLICATIONS INFORMATION

Thermal Lockout

If the die temperature reaches approximately 165°C, the part will go into thermal lockout, the power switch will be turned off and the soft-start capacitor will be discharged. The part will be enabled again when the die temperature has dropped by ~5°C (nominal).

Thermal Calculations

Power dissipation in the LT8570/LT8570-1 chip comes from four primary sources: switch I^2R loss, NPN base drive (AC), NPN base drive (DC), and additional input current. The following formulas can be used to approximate the power losses. These formulas assume continuous mode operation, so they should not be used for calculating efficiency in discontinuous mode or at light load currents.

$$\text{Average Input Current: } I_{IN} = \frac{V_{OUT} \cdot I_{OUT}}{V_{IN} \cdot \eta}$$

$$\text{Switch Conduction Loss: } P_{SW} = (DC)(I_{IN})(V_{SW})$$

$$\text{Base Drive Loss (AC): } P_{BAC} = 20\text{ns}(I_{IN})(V_{OUT})(f)$$

$$\text{Base Drive Loss (DC): } P_{BDC} = \frac{(V_{IN})(I_{IN})(DC)}{40}$$

$$\text{Input Power Loss: } P_{INP} = 4.5\text{mA}(V_{IN})$$

where:

V_{SW} = switch on voltage (see Typical Performance Characteristics for Switch Saturation Voltage)

DC = duty cycle (see the Power Switch Duty Cycle section for formulas)

η = power conversion efficiency (typically 85% at high currents)

Example: LT8570 in boost configuration, $V_{IN} = 5\text{V}$, $V_{OUT} = 12\text{V}$, $I_{OUT} = 0.1\text{A}$, $f = 1.25\text{MHz}$, $V_D = 0.5\text{V}$:

$$I_{IN} = 0.28\text{A}$$

$$DC = 62.0\%$$

$$P_{SW} = 32\text{mW}$$

$$P_{BAC} = 85\text{mW}$$

$$P_{BDC} = 22\text{mW}$$

$$P_{INP} = 23\text{mW}$$

$$\text{Total LT8570 power dissipation } (P_{TOT}) = 161\text{mW}$$

Thermal resistance for the LT8570/LT8570-1 is influenced by the presence of internal, topside or backside planes. To calculate die temperature, use the appropriate thermal resistance number and add in worst-case ambient temperature:

$$T_J = T_A + \theta_{JA} \cdot P_{TOT}$$

where T_J = junction temperature, T_A = ambient temperature, and θ_{JA} is the thermal resistance from the silicon junction to the ambient air.

The published θ_{JA} value is 43°C/W for the 3mm × 3mm DFN package and 35°C/W to 40°C/W for the MSOP exposed pad package. In practice, lower θ_{JA} values can be obtained if the board layout uses ground as a heat sink. For instance, thermal resistances of 34.7°C/W for the DFN package and 22.5°C/W for the MSOP package were obtained on a board designed with large ground planes.

V_{IN} Ramp Rate

While initially powering a switching converter application, the V_{IN} ramp rate should be limited. High V_{IN} ramp rates can cause excessive inrush currents in the passive components of the converter. This can lead to current and/or voltage overstress and may damage the passive components or the chip. Ramp rates less than 500mV/μs, depending on component parameters, will generally prevent these issues. Also, be careful to avoid hot-plugging. Hot-plugging occurs when an active voltage supply is “instantly” connected or switched to the input of the converter. Hot-plugging results in very fast input ramp rates and is not recommended. Finally, for more information, refer to Linear application note AN88, which discusses voltage overstress that can occur when an inductive source impedance is hot-plugged to an input pin bypassed by ceramic capacitors.

APPLICATIONS INFORMATION

Layout Hints

As with all high frequency switchers, when considering layout, care must be taken to achieve optimal electrical, thermal and noise performance. One will not get advertised performance with a careless layout. For maximum efficiency, switch rise and fall times are typically in the 10ns to 20ns range. To prevent noise, both radiated and conducted, the high speed switching current path, shown in Figure 9, must be kept as short as possible. This is implemented in the suggested layout of a boost configuration in Figure 10. Shortening this path will also reduce the parasitic trace inductance. At switch-off, this parasitic inductance produces a flyback spike across the LT8570/LT8570-1 switch. When operating at higher currents and output voltages, with poor layout, this spike can generate voltages across the LT8570/LT8570-1 that may exceed the absolute maximum rating. A ground plane should also be used under the switcher circuitry to prevent interplane coupling and overall noise.

The VC and FBX components should be kept as far away as practical from the switch node, while still remaining close to the chip. The ground for these components should be separated from the switch current path. Failure to do so can result in poor stability or subharmonic oscillation.

Board layout also has a significant effect on thermal resistance. The exposed package ground pad is the copper plate that runs under the LT8570/LT8570-1 die. This is

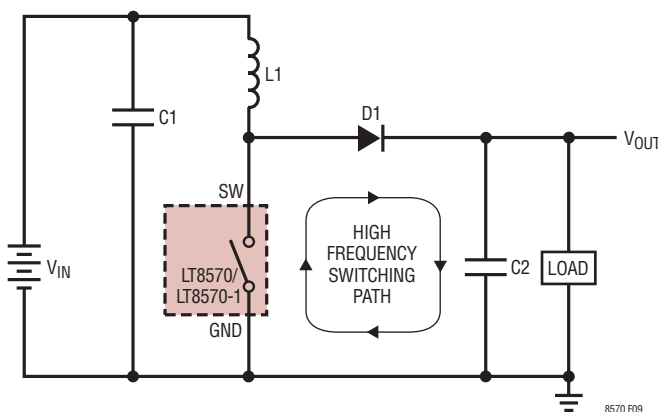

Figure 9. High Speed “Chopped” Switching Path for Boost Topology

a good thermal path for heat out of the package. Soldering the pad onto the board reduces die temperature and increases the power capability of the LT8570/LT8570-1. Provide as much copper area as possible around this pad. Adding multiple feedthroughs around the pad to the ground plane will also help. Figure 10 and Figure 11 show the recommended component placement for the boost and SEPIC configurations, respectively.

Layout Hints for Inverting Topology

Figure 12 shows recommended component placement for the dual inductor inverting topology. Input bypass capacitor, C1, should be placed close to the LT8570/LT8570-1, as shown. The load should connect directly to the output capacitor, C2, for best load regulation. The local ground may be tied into the system ground plane at the C3 ground terminal.

The cut ground copper at D1’s cathode is essential to obtain low noise. This important layout issue arises due to the chopped nature of the currents flowing in Q1 and D1. If they are both tied directly to the ground plane before being combined, switching noise will be introduced into the ground plane. It is almost impossible to get rid of this noise, once present in the ground plane. The solution is to tie D1’s cathode to the ground pin of the LT8570/LT8570-1 before the combined currents are dumped in the ground plane as drawn in Figure 12, Figure 13 and Figure 14. This single layout technique can virtually eliminate high frequency “spike” noise, so often present on switching regulator outputs.

Differences from LT3580

LT8570/LT8570-1 are very similar to LT3580. However, LT8570/LT8570-1 do deviate from LT3580 in a few areas:

- 65V, 0.5A switch for LT8570
- 65V, 0.25A switch for LT8570-1
- 40V V_{IN} and \overline{SHDN} absolute maximum rating
- FB renamed to FBX
- 5V FBX absolute maximum rating

APPLICATIONS INFORMATION

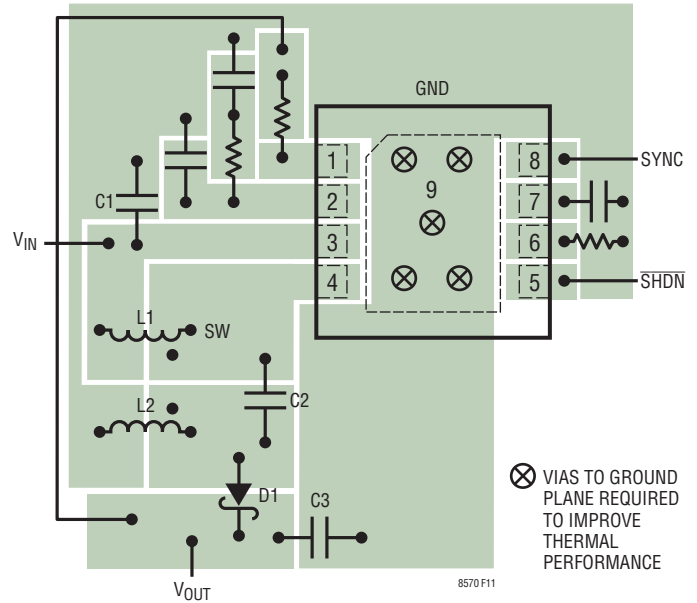
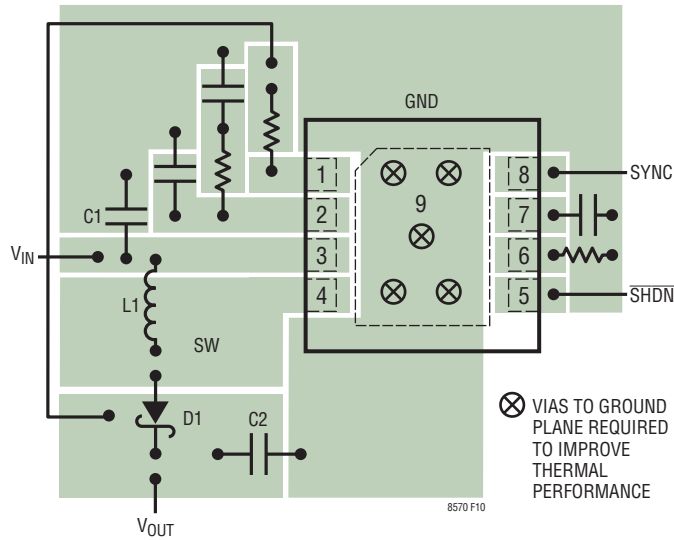

Figure 10. Suggested Component Placement for Boost Topology (Both DFN and MSOP Packages. Not to Scale). Pin 9 (Exposed Pad) Must Be Soldered Directly to the Local Ground Plane for Adequate Thermal Performance. Multiple Vias to Additional Ground Planes Will Improve Thermal Performance

Figure 11. Suggested Component Placement for SEPIC Topology (Both DFN and MSOP Packages. Not to Scale). Pin 9 (Exposed Pad) Must Be Soldered Directly to the Local Ground Plane for Adequate Thermal Performance. Multiple Vias to Additional Ground Planes Will Improve Thermal Performance

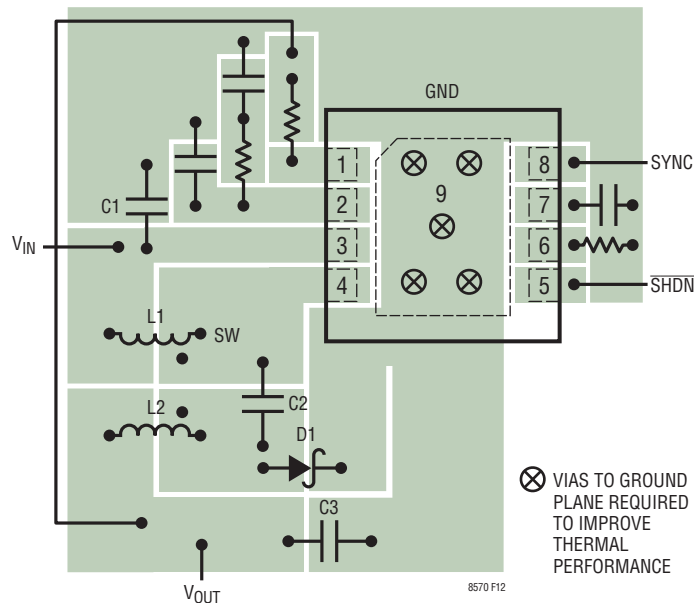

Figure 12. Suggested Component Placement for Inverting Topology (Both DFN and MSOP Packages. Not to Scale). Note Cut in Ground Copper at Diode's Cathode. Pin 9 (Exposed Pad) Must Be Soldered Directly to Local Ground Plane for Adequate Thermal Performance. Multiple Vias to Additional Ground Planes Will Improve Thermal Performance

APPLICATIONS INFORMATION

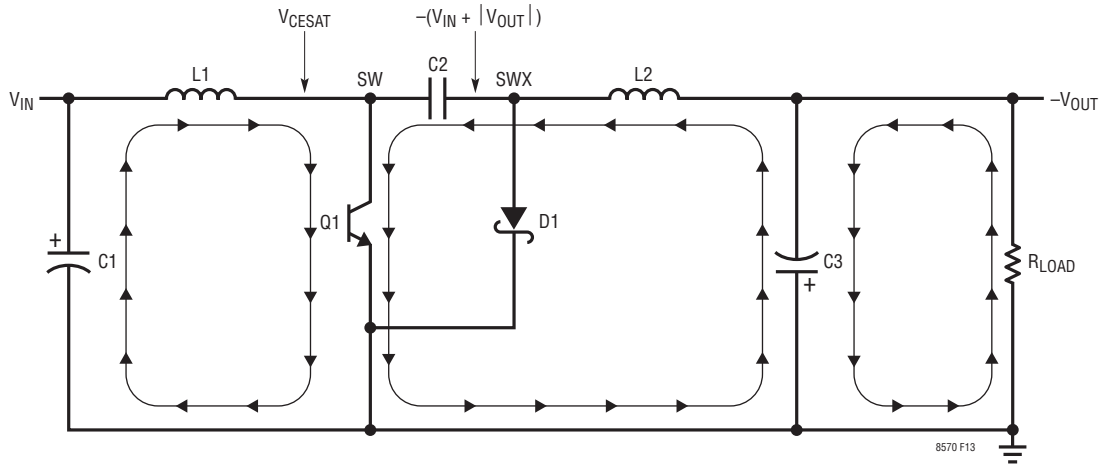

Figure 13. Switch-On Phase of an Inverting Converter. L1 and L2 Have Positive di/dt

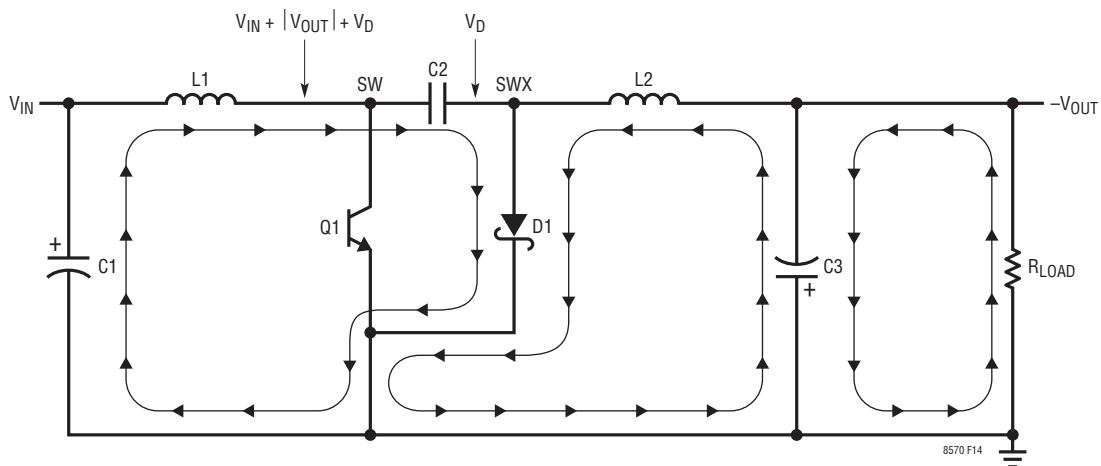

Figure 14. Switch-Off Phase of an Inverting Converter. L1 and L2 Currents Have Negative di/dt

APPLICATIONS INFORMATION

BOOST CONVERTER COMPONENT SELECTION

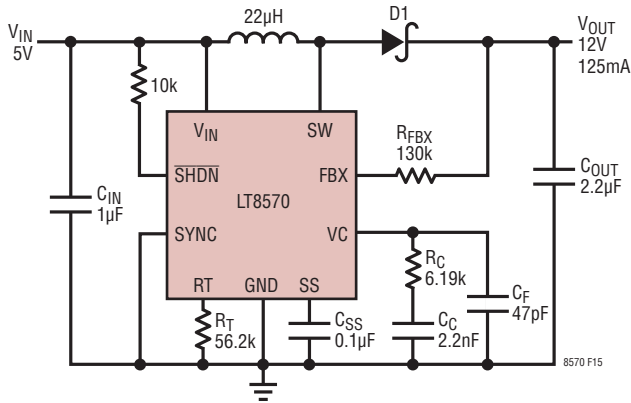

Figure 15. Boost Converter: The Component Values Given Are Typical Values for a 1.5MHz, 5V to 12V Boost

The LT8570/LT8570-1 can be configured as a boost converter as in Figure 15. This topology allows for positive output voltages that are higher than the input voltage. A single feedback resistor sets the output voltage. For output voltages higher than 60V, see the Charge Pump Aided Regulators section.

For a desired output voltage over a given input voltage range, Table 4 is a step-by-step set of equations to calculate component values for the LT8570/LT8570-1 when operating as a boost converter. Refer to the Applications Information section for further information on the design equations presented in Table 4.

Variable Definitions:

V_{IN} = Input Voltage

V_{OUT} = Output Voltage

DC = Power Switch Duty Cycle

f_{OSC} = Switching Frequency

I_{OUT} = Maximum Average Output Current

I_{RIPPLE} = Inductor Ripple Current

I_{RTYP} = 150mA for LT8570 and 75mA for LT8570-1

k_{SC} = 0.6A for LT8570 and 0.3A for LT8570-1

I_{RMIN} = 0.04A for LT8570 and 0.02A for LT8570-1

I_{LIM} = 0.5A for LT8570 and 0.25A for LT8570-1

Table 4. Boost Design Equations

	PARAMETERS/EQUATIONS
Step 1: Inputs	Pick V_{IN} , V_{OUT} , and f_{OSC} to calculate equations below
Step 2: DC	$DC_{MAX} = \frac{V_{OUT} - V_{IN(MIN)} + 0.5V}{V_{OUT} + 0.5V - 0.4V}$ $DC_{MIN} = \frac{V_{OUT} - V_{IN(MAX)} + 0.5V}{V_{OUT} + 0.5V - 0.4V}$
Step 3: L1	$L_{TYP} = \frac{(V_{IN(MIN)} - 0.4V) \cdot DC_{MAX}}{f_{OSC} \cdot I_{RTYP}} \quad (1)$ $L_{MIN} = \frac{(V_{IN(MIN)} - 0.4V) \cdot (2 \cdot DC_{MAX} - 1)}{k_{SC} \cdot (DC_{MAX} - 300ns \cdot f_{OSC}) \cdot f_{OSC} \cdot (1 - DC_{MAX})} \quad (2)$ $L_{MAX1} = \frac{(V_{IN(MIN)} - 0.4V) \cdot DC_{MAX}}{f_{OSC} \cdot I_{RMIN}} \quad (3)$ $L_{MAX2} = \frac{(V_{IN(MAX)} - 0.4V) \cdot DC_{MIN}}{f_{OSC} \cdot I_{RMIN}} \quad (4)$ <ul style="list-style-type: none"> Solve equations 1 to 4 for a range of L values The minimum of the L value range is the higher of L_{TYP} and L_{MIN} The maximum of the L value range is the lower of L_{MAX1} and L_{MAX2}
Step 4: I_{RIPPLE}	$I_{RIPPLE(MIN)} = \frac{(V_{IN(MIN)} - 0.4V) \cdot DC_{MAX}}{f_{OSC} \cdot L_1}$ $I_{RIPPLE(MAX)} = \frac{(V_{IN(MAX)} - 0.4V) \cdot DC_{MIN}}{f_{OSC} \cdot L_1}$
Step 5: I_{OUT}	$I_{OUT(MIN)} = \left(I_{LIM} - \frac{I_{RIPPLE(MIN)}}{2} \right) \cdot (1 - DC_{MAX})$ $I_{OUT(MAX)} = \left(I_{LIM} - \frac{I_{RIPPLE(MAX)}}{2} \right) \cdot (1 - DC_{MIN})$
Step 6: D1	$V_R > V_{OUT}$; $I_{AVG} > I_{OUT}$
Step 7: C_{OUT}	$C_{OUT} \geq \frac{I_{OUT} \cdot DC_{MAX}}{f_{OSC} \cdot 0.005 \cdot V_{OUT}}$
Step 8: C_{IN}	$C_{IN} \geq C_{VIN} + C_{PWR} \geq \frac{I_{LIM} \cdot DC_{MAX}}{40 \cdot f_{OSC} \cdot 0.005 \cdot V_{IN(MIN)}} + \frac{I_{RIPPLE(MAX)}}{8 \cdot f_{OSC} \cdot 0.005 \cdot V_{IN(MAX)}}$ <ul style="list-style-type: none"> Refer to the Capacitor Selection Section for definition of C_{VIN} and C_{PWR}.
Step 9: R_{FBK}	$R_{FBK} = \frac{V_{OUT} - 1.204V}{83.3\mu A}$
Step 10: R_T	$R_T = \frac{85.5}{f_{OSC}} - 1$; f_{OSC} in MHz and R_T in k Ω

Note 1: This table uses 0.5A and 0.25A for the peak switch current. Refer to the Electrical Characteristics Table and Typical Performance Characteristics plots for the peak switch current at an operating duty cycle.

Note 2: The final values for C_{OUT} and C_{IN} may deviate from the previous equations in order to obtain desired load transient performance.

APPLICATIONS INFORMATION

SEPIC CONVERTER COMPONENT SELECTION (COUPLED OR UNCOUPLED INDUCTORS)

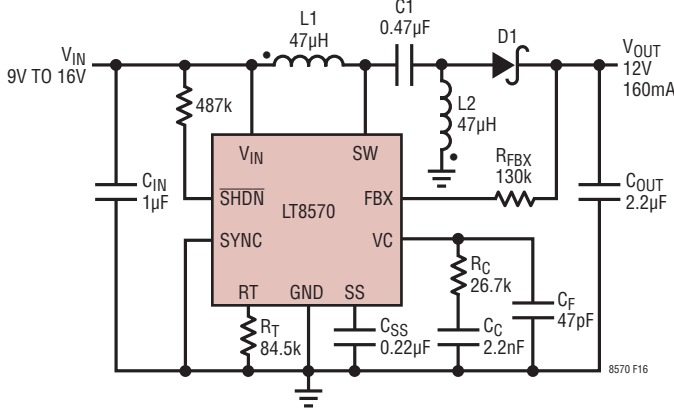

Figure 16. SEPIC Converter: The Component Values and Voltages Given Are Typical Values for a 1MHz, 9V-16V to 12V SEPIC Converter Using Coupled Inductors

Figure 16 shows the LT8570 configured as a SEPIC. This topology allows for positive output voltages that are lower, equal or higher than the input voltage. Output disconnect is inherent to the SEPIC topology, meaning no DC path exists between the input and output due to capacitor C1.

For a desired output voltage over a given input voltage range, Table 5 is a step-by-step set of equations to calculate component values for the LT8570/LT8570-1 when operating as a SEPIC converter. Refer to the Applications Information section for further information on the design equations presented in Table 5.

Variable Definitions:

V_{IN} = Input Voltage

V_{OUT} = Output Voltage

DC = Power Switch Duty Cycle

f_{OSC} = Switching Frequency

I_{OUT} = Maximum Average Output Current

I_{RIPPLE} = Inductor Ripple Current

I_{RTYP} = 150mA for LT8570 and 75mA for LT8570-1

k_{SC} = 0.6A for LT8570 and 0.3A for LT8570-1

I_{RMIN} = 0.04A for LT8570 and 0.02A for LT8570-1

I_{LIM} = 0.5A for LT8570 and 0.25A for LT8570-1

Table 5. SEPIC Design Equations

	PARAMETERS/EQUATIONS
Step 1: Inputs	Pick V_{IN} , V_{OUT} and f_{OSC} to calculate equations below
Step 2: DC	$DC_{MAX} = \frac{V_{OUT} + 0.5V}{V_{IN(MIN)} + V_{OUT} + 0.5V - 0.4V}$ $DC_{MIN} = \frac{V_{OUT} + 0.5V}{V_{IN(MAX)} + V_{OUT} + 0.5V - 0.4V}$
Step 3: L	$L_{TYP} = \frac{(V_{IN(MIN)} - 0.4V) \cdot DC_{MAX}}{f_{OSC} \cdot I_{RTYP}} \quad (1)$ $L_{MIN} = \frac{(V_{IN(MIN)} - 0.4V) \cdot (2 \cdot DC_{MAX} - 1)}{k_{SC} \cdot (DC_{MAX} - 300ns) \cdot f_{OSC} \cdot f_{OSC} \cdot (1 - DC_{MAX})} \quad (2)$ $L_{MAX} = \frac{(V_{IN(MIN)} - 0.4V) \cdot DC_{MAX}}{f_{OSC} \cdot I_{RMIN}} \quad (3)$ <ul style="list-style-type: none"> Solve equations 1, 2 and 3 for a range of L values The minimum of the L value range is the higher of L_{TYP} and L_{MIN} The maximum of the L value range is L_{MAX} $L = L1 = L2$ for coupled inductors $L = L1 \parallel L2$ for uncoupled inductors
Step 4: IRIPPLE	$I_{RIPPLE(MIN)} = \frac{(V_{IN(MIN)} - 0.4V) \cdot DC_{MAX}}{f_{OSC} \cdot L}$ $I_{RIPPLE(MAX)} = \frac{(V_{IN(MAX)} - 0.4V) \cdot DC_{MIN}}{f_{OSC} \cdot L}$
Step 5: IOUT	$I_{OUT(MIN)} = \left(I_{LIM} - \frac{I_{RIPPLE(MIN)}}{2} \right) \cdot (1 - DC_{MAX})$ $I_{OUT(MAX)} = \left(I_{LIM} - \frac{I_{RIPPLE(MAX)}}{2} \right) \cdot (1 - DC_{MIN})$
Step 6: D1	$V_R > V_{IN} + V_{OUT}$; $I_{AVG} > I_{OUT}$
Step 7: C1	$V_{RATING} \geq V_{IN}$ $C1 \geq 0.47\mu F$ for LT8570, $C1 \geq 0.22\mu F$ for LT8570-1
Step 8: COUT	$C_{OUT} \geq \frac{I_{OUT(MIN)} \cdot DC_{MAX}}{f_{OSC} \cdot 0.005 \cdot V_{OUT}}$
Step 9: CIN	$C_{IN} \geq C_{VIN} + C_{PWR} \geq \frac{I_{LIM} \cdot DC_{MAX}}{40 \cdot f_{OSC} \cdot 0.005 \cdot V_{IN(MIN)}} + \frac{I_{RIPPLE(MAX)}}{8 \cdot f_{OSC} \cdot 0.005 \cdot V_{IN(MAX)}}$ <ul style="list-style-type: none"> Refer to the Capacitor Selection Section for definition of C_{VIN} and C_{PWR}
Step 10: RFBX	$R_{FBX} = \frac{V_{OUT} - 1.204V}{83.3\mu A}$
Step 11: RT	$R_T = \frac{85.5}{f_{OSC}} - 1$; f_{OSC} in MHz and R_T in k Ω

Note 1: This table uses 0.5A and 0.25A for the peak switch current. Refer to the Electrical Characteristics Table and Typical Performance Characteristics plots for the peak switch current at an operating duty cycle.

Note 2: The final values for C_{OUT} , C_{IN} and C1 may deviate from the previous equations in order to obtain desired load transient performance.

85701fa

APPLICATIONS INFORMATION

DUAL INDUCTOR INVERTING CONVERTER COMPONENT SELECTION (COUPLED OR UNCOUPLED INDUCTORS)

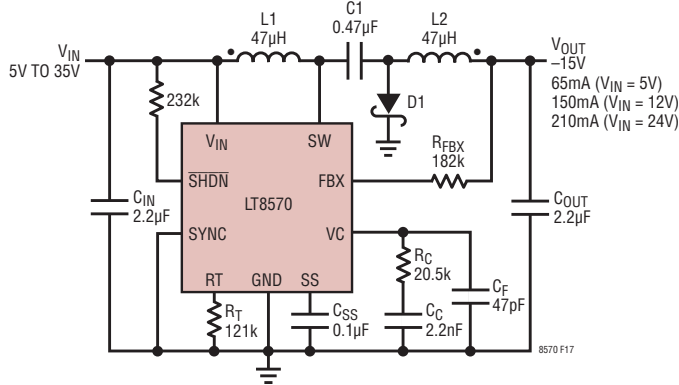

Figure 17. Dual Inductor Inverting Converter: The Component Values Given Are Typical Values for a 700kHz 5V-35V to -15V Inverting Topology Using Coupled Inductors

Due to its unique FBX pin, the LT8570/LT8570-1 can work in an inverting configuration as in Figure 17. Changing the connections of L2 and the Schottky diode in the SEPIC topology results in negative output voltages. Output disconnect is inherently built into this topology due to the capacitor C1.

For a desired output voltage over a given input voltage range, Table 6 is a step-by-step set of equations to calculate component values for the LT8570/LT8570-1 when operating as a dual inductor inverting converter. Refer to the Applications Information section for further information on the design equations presented in Table 6.

Variable Definitions:

V_{IN} = Input Voltage

V_{OUT} = Output Voltage

DC = Power Switch Duty Cycle

f_{OSC} = Switching Frequency

I_{OUT} = Maximum Average Output Current

I_{RIPPLE} = Inductor Ripple Current

I_{RTYP} = 150mA for LT8570 and 75mA for LT8570-1

k_{SC} = 0.6A for LT8570 and 0.3A for LT8570-1

I_{RMIN} = 0.04A for LT8570 and 0.02A for LT8570-1

I_{LIM} = 0.5A for LT8570 and 0.25A for LT8570-1

Table 6. Dual Inductor Inverting Design Equations

	PARAMETERS/EQUATIONS
Step 1: Inputs	Pick V_{IN} , V_{OUT} and f_{OSC} to calculate equations below
Step 2: DC	$DC_{MAX} = \frac{ V_{OUT} + 0.5V}{V_{IN(MIN)} + V_{OUT} + 0.5V - 0.4V}$ $DC_{MIN} = \frac{ V_{OUT} + 0.5V}{V_{IN(MAX)} + V_{OUT} + 0.5V - 0.4V}$
Step 3: L	$L_{TYP} = \frac{(V_{IN(MIN)} - 0.4V) \cdot DC_{MAX}}{f_{OSC} \cdot I_{RTYP}} \quad (1)$ $L_{MIN} = \frac{(V_{IN(MIN)} - 0.4V) \cdot (2 \cdot DC_{MAX} - 1)}{k_{SC} \cdot (DC_{MAX} - 300ns \cdot f_{OSC}) \cdot f_{OSC} \cdot (1 - DC_{MAX})} \quad (2)$ $L_{MAX} = \frac{(V_{IN(MIN)} - 0.4V) \cdot DC_{MAX}}{f_{OSC} \cdot I_{RMIN}} \quad (3)$ <ul style="list-style-type: none"> Solve equations 1, 2 and 3 for a range of L values The minimum of the L value range is the higher of L_{TYP} and L_{MIN} The maximum of the L value range is L_{MAX} $L = L1 = L2$ for coupled inductors $L = L1 L2$ for uncoupled inductors
Step 4: I_{RIPPLE}	$I_{RIPPLE(MIN)} = \frac{(V_{IN(MIN)} - 0.4V) \cdot DC_{MAX}}{f_{OSC} \cdot L}$ $I_{RIPPLE(MAX)} = \frac{(V_{IN(MAX)} - 0.4V) \cdot DC_{MIN}}{f_{OSC} \cdot L}$
Step 5: I_{OUT}	$I_{OUT(MIN)} = \left(I_{LIM} - \frac{I_{RIPPLE(MIN)}}{2} \right) \cdot (1 - DC_{MAX})$ $I_{OUT(MAX)} = \left(I_{LIM} - \frac{I_{RIPPLE(MAX)}}{2} \right) \cdot (1 - DC_{MIN})$
Step 6: D1	$V_R > V_{IN} + V_{OUT} $; $I_{AVG} > I_{OUT}$
Step 7: C1	$V_{RATING} \geq V_{IN(MAX)} + V_{OUT} $ $C1 \geq 0.47\mu F$ for LT8570, $C1 \geq 0.22\mu F$ for LT8570-1
Step 8: C_{OUT}	$C_{OUT} \geq \frac{I_{RIPPLE(MAX)}}{8 \cdot f_{OSC} \cdot (0.005 \cdot V_{OUT})}$
Step 9: C_{IN}	$C_{IN} \geq C_{VIN} + C_{PWR} \geq \frac{I_{LIM} \cdot DC_{MAX}}{40 \cdot f_{OSC} \cdot 0.005 \cdot V_{IN(MIN)}} + \frac{I_{RIPPLE(MAX)}}{8 \cdot f_{OSC} \cdot 0.005 \cdot V_{IN(MAX)}}$ <ul style="list-style-type: none"> Refer to the Capacitor Selection Section for definition of C_{VIN} and C_{PWR}
Step 10: R_{FBX}	$R_{FBX} = \frac{ V_{OUT} + 3mV}{83.3\mu A}$
Step 11: R_T	$R_T = \frac{85.5}{f_{OSC}} - 1$; f_{OSC} in MHz and R_T in k Ω

Note 1: This table uses 0.5A and 0.25A for the peak switch current. Refer to the Electrical Characteristics Table and Typical Performance Characteristics plots for the peak switch current at an operating duty cycle.

Note 2: The final values for C_{OUT} , C_{IN} and C1 may deviate from the previous equations in order to obtain desired load transient performance.

TYPICAL APPLICATIONS

1.5MHz, 5V to 12V Output Boost Converter

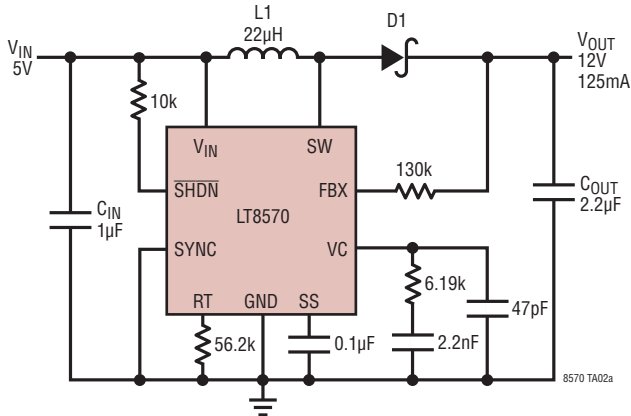

L1: WÜRTH 22µH WE-LQS 74404042220
 D1: DIODES INC. PD3S140
 CIN: 1µF, 16V, 0805, X7R
 COUT: 2.2µF, 16V, 0805, X7R

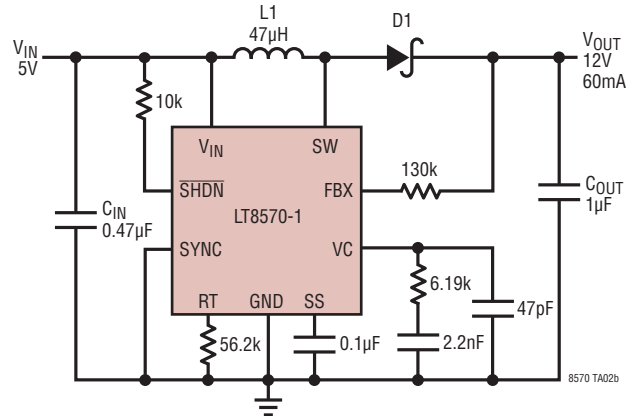

L1: WÜRTH 47µH WE-LQS 74404032470
 D1: DIODES INC. PD3S140
 CIN: 0.47µF, 16V, 0805, X7R
 COUT: 1µF, 16V, 0805, X7R

Efficiency and Power Loss (LT8570)

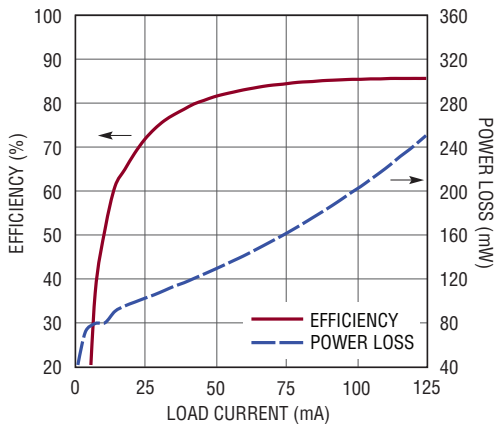

8570 TA02c

Efficiency and Power Loss (LT8570-1)

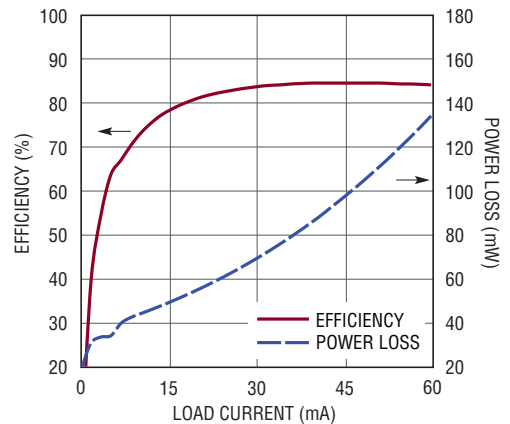

8570 TA02d

30mA to 90mA to 30mA Output Load Step (LT8570)

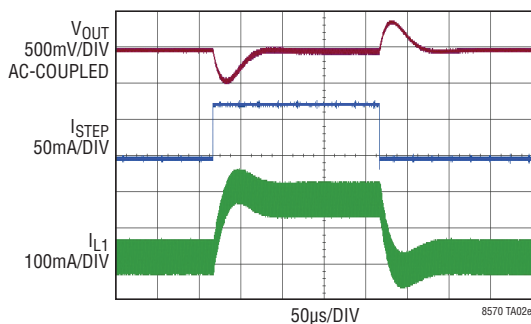

8570 TA02e

15mA to 45mA to 15mA Output Load Step (LT8570-1)

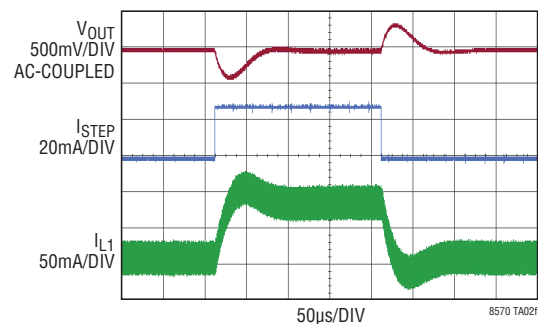

8570 TA02f