



Chipsmall Limited consists of a professional team with an average of over 10 year of expertise in the distribution of electronic components. Based in Hongkong, we have already established firm and mutual-benefit business relationships with customers from,Europe,America and south Asia,supplying obsolete and hard-to-find components to meet their specific needs.

With the principle of “Quality Parts,Customers Priority,Honest Operation,and Considerate Service”,our business mainly focus on the distribution of electronic components. Line cards we deal with include Microchip,ALPS,ROHM,Xilinx,Pulse,ON,Everlight and Freescale. Main products comprise IC,Modules,Potentiometer,IC Socket,Relay,Connector.Our parts cover such applications as commercial,industrial, and automotives areas.

We are looking forward to setting up business relationship with you and hope to provide you with the best service and solution. Let us make a better world for our industry!



Contact us

Tel: +86-755-8981 8866 Fax: +86-755-8427 6832

Email & Skype: info@chipsmall.com Web: www.chipsmall.com

Address: A1208, Overseas Decoration Building, #122 Zhenhua RD., Futian, Shenzhen, China



FEATURES

- (1) Landscape 7" WVGA(800x480 pixels) display(15:9 Aspect Ratio)
- (2) RGB 6bit(3.3V C-MOS Parallel Interface)
- (3) High Luminance & Wide Viewing Angle
- (4) Applicable longer life(50,000hours CCFL MTBF@6.0mA)
- (5) Resistance type touch panel assemble(4 wire type, Except controller)

TENTATIVE

MECHANICAL SPECIFICATIONS

Item	Specifications
Dimensional Outline (typ.)	170.8(W) x 110.0(H) x 10.0(D) mm(Max.)
Number of Pixels	800(W) x 480(H) pixels
Active Area	152.4(W) x 91.44(H) mm
Pixel Pitch	0.1905(W) x 0.1905(H)
Weight (approximately)	240 g
Backlight	CCFL, Sidelight type

ABSOLUTE MAXIMUM RATINGS

Item		Min.	Max.	Unit
Supply Voltage	(V _{DD})	-0.3	4.0	V
	(V _{FL})	0	2.0	kV(rms)
FL Driving Frequency (f _{FL})		-	100	kV
Input Signal Voltage		-0.3	V _{DD} +0.3	V
Operating Temperature		-10	60	°C
Storage Temperature		-20	70	°C
Operating Humidity		20	90	%RH
Storage Humidity		10	90	%RH

ELECTRICAL SPECIFICATION

Item		Min.	Typ.	Max.	Unit	Remarks
Supply Voltage	(V _{DD})	3.0	3.3	3.6	V	
	(V _{FL})	---	350	---	V(rms)	I _{FL} =7.0mA(rms)
FL Start Voltage		1050	---	---	V	At -20degreeC
"H" level input voltage(V _{IH})		0.7V _{DD}	---	V _{DD}	V	
"L" level input voltage(V _{IL})		0	---	0.3 V _{DD}	V	
Power Consumption	I _{DD}	---	200	350	mA	Color bar pattern
	I _{FL}	---	7.0	7.5	mA	

OPTICAL SPECIFICATION (T_a=25°C)

Item		Min.	Typ.	Max.	Unit	Remarks
Contrast Ratio (CR)		300	450	---	---	
Response Time	(t _{ON})	---	11	22	msec	
	(t _{OFF})	---	22	44	msec	
Viewing Angle CR>10	Top/Bottom	40/45	50/60	---	°	
	Left/Right	45/45	60/60	---	°	
Luminance (L)		220	280	---	cd/m ²	I _{FL} =7.0mA(rms)
		205	260	---	cd/m ²	I _{FL} =6.0mA(rms)
Color Chromaticity	W _x	---	0.315	---	---	
	W _y	---	0.340	---	---	
Lamp Life Time(MTBF) ^{1,2}			30,000		Hours	I _{FL} =7.0mA(rms)
			50,000		Hours	I _{FL} =6.0mA(rms)

*1 : Conditions ; T_a=25°C, I_{FL}=6.0mA(rms), continuous lighting

*2 : Definitions of failure ; 1) Lcd luminance becomes half of the minimum value. 2) Lamp doesn't light normally.

*The information contained herein is presented only as a guide for the applications of our products. No responsibility is assumed by Toshiba Matsushita Display Technology or other rights of the third parties which may result from its use. No license is granted by implication or otherwise under any patent or patent rights of Toshiba Matsushita Display technology or others.

*The information contained herein may be changed without prior notice. It is therefore advisable to contact Toshiba Matsushita Display Technology before proceeding with the design of equipment incorporating this product.

<Touch Panel Condition>

Recommended Operating Conditions

Item		Min.	Typ.	Max.	Unit	Remarks
Supply Voltage	V_{TP}	---	5.0	7.0	V	

Electrical Specifications

Item		Min.	Typ.	Max.	Unit	Remarks	
Insulation Resistance	Z	20	---	---	MOhm	DC25V	
Resistance between Terminals	#1 - #3(X)	R_x	200	---	1500	Ohm	Measured at connector pin(including conductor resistance).
	#2 - #4(Y)	R_y	100	---	600		
Linearity	-			1.5	%		
Chattering	-			10	msec		

Mechanical Specifications

Item		Min.	Typ.	Max.	Unit	Remarks
Operating Starting Force		5	---	50	gf	
Surface Hardness		3			H	

DIMENSIONAL OUTLINE

Unit : mm
Standard tolerance : ±0.5

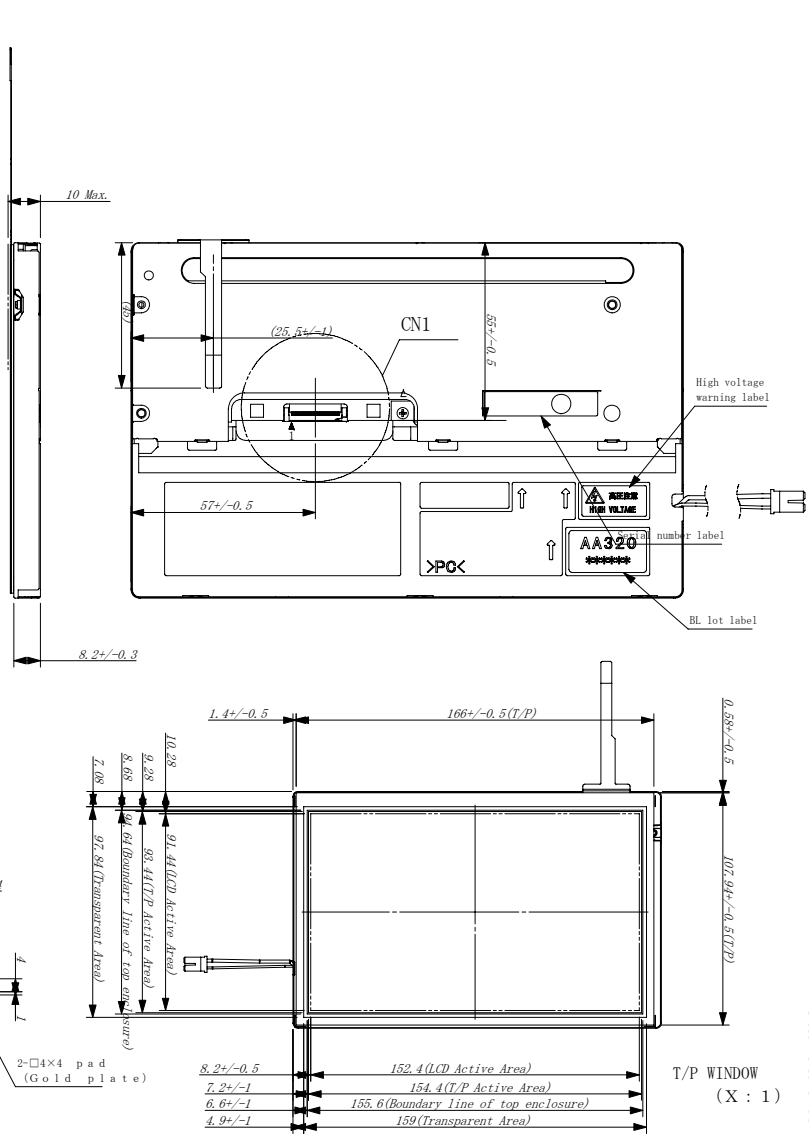

- Notes:
- Standard tolerance: ±0.5
 - CN1: FA5B030HP1 (JAE)
 - CN2: BHSR-02VS-1N (JST)

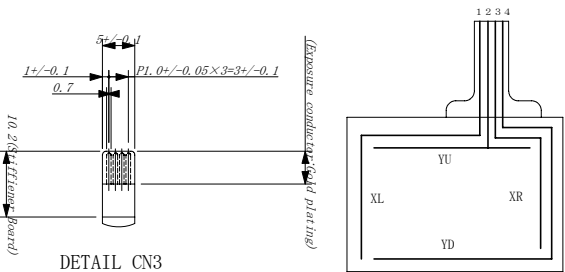
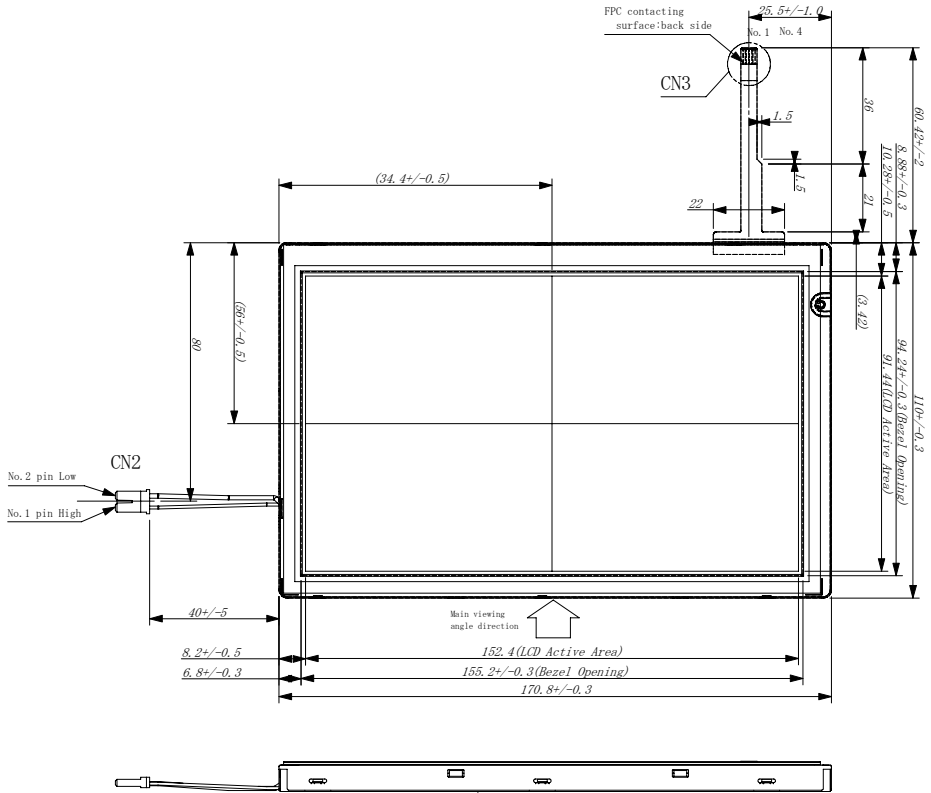

No.	Pin assign
1	XL
2	YU
3	XR
4	YD

Agreement connector :
FC1S004HA1 (JAE)

BLOCK DIAGRAM

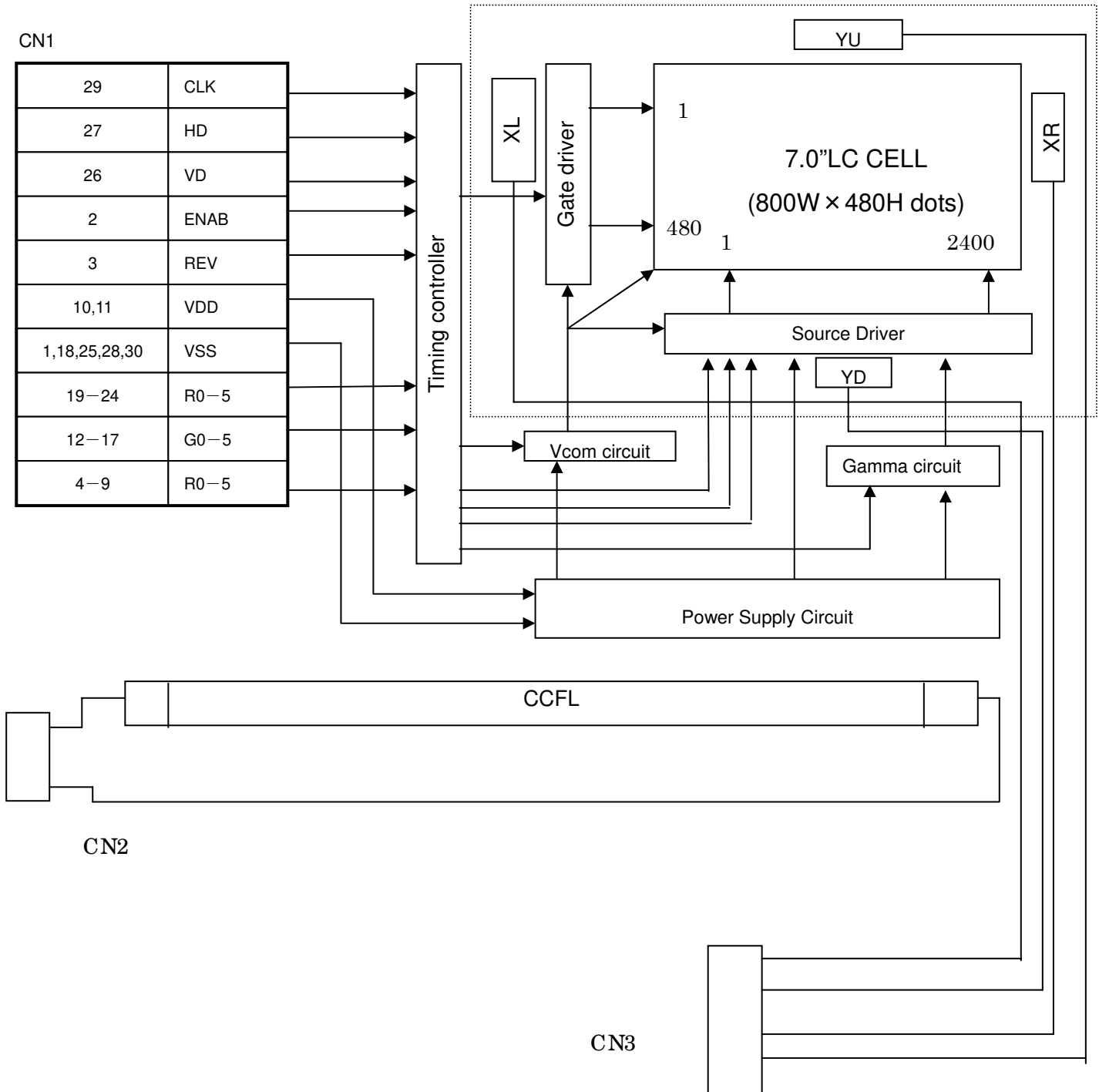

SEQUENCE OF POWER SUPPLIES AND SIGNALS (Note 1,2,3,4)

Note 1 : Please performs an input power supply sequence as follows.

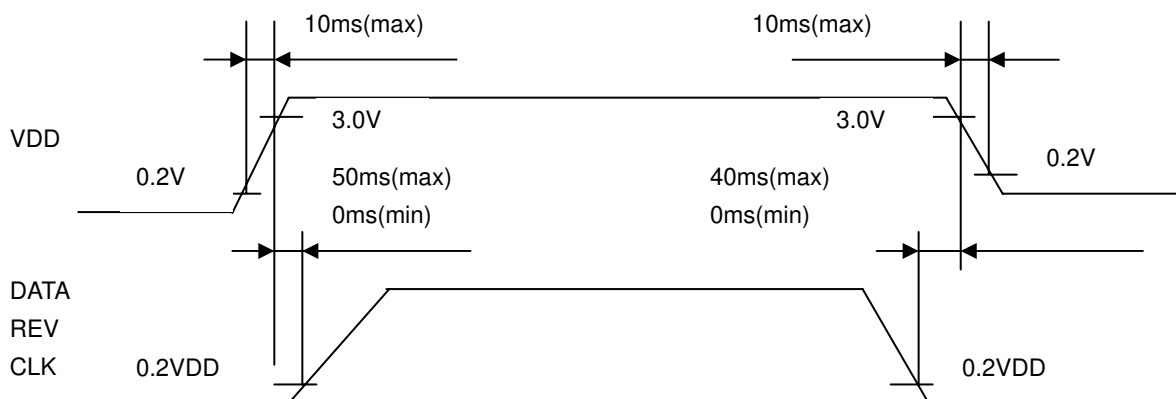

In setup other than the above, be sure to ask us.

Note 2 : Please connect REV terminal to ground (0V)

Note 3 : Refer to the electrical property standard and the timing specification for the electric specification of each signal.

Note 4 : The relation between display data and story tone level is shown in the following table.

	Story tone Level	D5 (MSB)	D4	D3	D2	D1	D0 (LSB)
Black ⋮ ⋮ ⋮ ⋮ ⋮ ⋮ White	L0	LO	LO	LO	LO	LO	LO
	L1	LO	LO	LO	LO	LO	Hi
	L2	LO	LO	LO	LO	Hi	LO
	⋮	⋮	⋮	⋮	⋮	⋮	⋮
	⋮	⋮	⋮	⋮	⋮	⋮	⋮
	L61	Hi	Hi	Hi	Hi	LO	Hi
	L62	Hi	Hi	Hi	Hi	Hi	LO
L63	Hi	Hi	Hi	Hi	Hi	Hi	

TIMING CHART

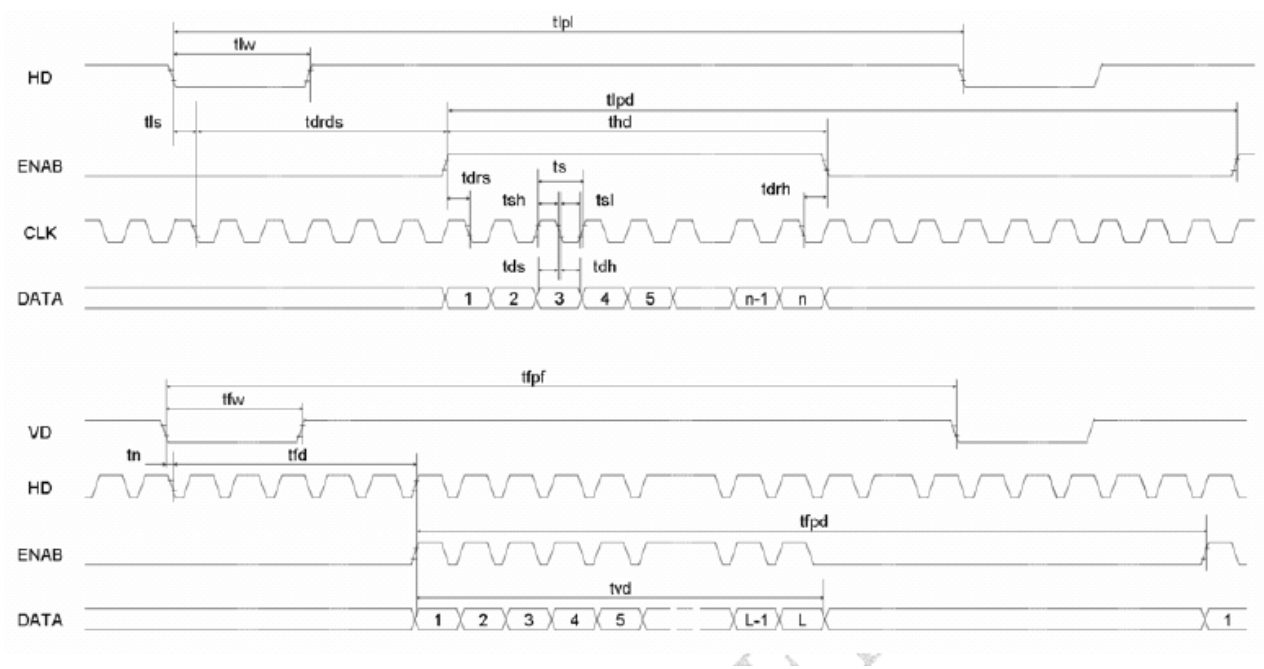

TIMING SPECIFICATION

	Item	Symbol	Min.	Typ.	Max.	Unit
Clock	Frequency	1/ts	-	33.231	36.2	MHz
	Period	ts	27.6	30.1	-	ns
	High Time	tsh	7	-	-	ns
	Low Time	tsl	7	-	-	ns
	Duty	th/tl	35	50	65	
Data	Setup Time	tds	5	-	-	ns
	Pulse Width	tdh	2	-	-	ns
Horizontal Sync	Period	tlpl,tlpd	30.4 1024	31.8 1056	- 1088	us clk
	Pulse Width	tlw	3	64	100	clk
Horizontal Display	Period	thd	800			clk
	Sync Width + Back Porch	tdrds	50	216	300	clk
	Front Porch	tlpl-(tdrds+thd)	10	-	-	clk
Enable	Setup Time	tdrs	5	-	-	ns
	Hold Time	tdrh	2	-	-	ns
Vertical Sync	Period	tfpf,tfpd	500 59	525 60	550 65	line Hz
	Pulse Width	tfw	1	2	3	line
Vertical Display	Period	tvd	480			line
	Sync Width + Back Porch	tfd	10	33	50	line
	Front Porch	tfpf-(tfd+tvd)	1	-	-	line
Phase Difference	Horizontal Sync – Clock	tls	8	-	-	ns
	Horizontal Sync – Vertical	tn	8	-	-	bs

CONNECTOR PIN ASSIGNMENT FOR INTERFACE

CN1 INPUT SIGNAL

Using Connector : FA5B030HP1 / JAE

Terminal No.	Symbol	Function	Input/Output
1	GND	GND	---
2	CLK	Clock	Input
3	GND	GND	---
4	HD	Horizontal Sync	Input
5	VD	Vertical Sync	Input
6	GND	GND	---
7	R0	Red Display Data	Input
8	R1	Red Display Data	Input
9	R2	Red Display Data	Input
10	R3	Red Display Data	Input
11	R4	Red Display Data	Input
12	R5	Red Display Data	Input
13	GND	GND	---
14	G0	Green Display Data	Input
15	G1	Green Display Data	Input
16	G2	Green Display Data	Input
17	G3	Green Display Data	Input
18	G4	Green Display Data	Input
19	G5	Green Display Data	Input
20	VDD	Power Supply(+3.3V)	Input
21	VDD	Power Supply(+3.3V)	Input
22	B0	Blue Display Data	Input
23	B1	Blue Display Data	Input
24	B2	Blue Display Data	Input
25	B3	Blue Display Data	Input
26	B4	Blue Display Data	Input
27	B5	Blue Display Data	Input
28	REV	Reverse Scan Function Signal	Input
29	ENAB	Data Enable Signal	Input
30	GND	GND	---

CN2 CCFL POWER SOURCE

Using Connector : BHSR-02VS-1N / Japan SOLDERLESS TERMINAL MFG CO.,LTD

Mating Connector(Corresponding Connector)

: SM02B-BHSS-1 / Japan SOLDERLESS TERMINAL MFG CO.,LTD

Terminal No.	Symbol	Function
1	V _{FLH}	CCFL Power Supply (high voltage)
2	V _{FLL}	CCFL Power Supply (low voltage)

CN3 TOUCH PANEL

FPC: 1.0mm pitch

Mating connector: FC1S004HA1 / JAE

Terminal No.	Symbol	Function	Input/Output
1	XL	Touch Panel XL Terminal	Output
2	YU	Touch Panel YU Terminal	Output
3	XR	Touch Panel XR Terminal	Output
4	YD	Touch Panel YD Terminal	Output

COLORS COMBINATION TABLE

	Display	R5 R4 R3 R2 R1 R0	G5 G4 G3 G2 G1 G0	B5 B4 B3 B2 B1 B0	Gray Scale Level
Basic Color	Black	L L L L L L L	L L L L L L L	L L L L L L L	-
	Blue	L L L L L L L	L L L L L L L	H H H H H H H	-
	Green	L L L L L L L	H H H H H H H	L L L L L L L	-
	Light Blue	L L L L L L L	H H H H H H H	H H H H H H H	-
	Red	H H H H H H H	L L L L L L L	L L L L L L L	-
	Purple	H H H H H H H	L L L L L L L	H H H H H H H	-
	Yellow	H H H H H H H	H H H H H H H	L L L L L L L	-
Gray Scale of Red	Black	L L L L L L L	L L L L L L L	L L L L L L L	L 0
	Dark ↑ ↓ Light	L L L L L H L	L L L L L L L	L L L L L L L	L 1
		L L L L L L L	L L L L L L L	L L L L L L L	L 2
		⋮	⋮	⋮	L3... L60
	Light	H H H H L H L	L L L L L L L	L L L L L L L	L61
		H H H H H L L	L L L L L L L	L L L L L L L	L62
	Red	H H H H H H H	L L L L L L L	L L L L L L L	Red L63
Gray Scale of Green	Black	L L L L L L L	L L L L L L L	L L L L L L L	L 0
	Dark ↑ ↓ Light	L L L L L L L	L L L L L L H	L L L L L L L	L 1
		L L L L L L L	L L L L L H L	L L L L L L L	L 2
		⋮	⋮	⋮	L3... L60
	Light	L L L L L L L	H H H H L H H	L L L L L L L	L61
		L L L L L L L	H H H H H L L	L L L L L L L	L62
	Green	L L L L L L L	H H H H H H H	L L L L L L L	Green L63
Gray Scale of Blue	Black	L L L L L L L	L L L L L L L	L L L L L L L	L 0
	Dark ↑ ↓ Light	L L L L L L L	L L L L L L L	L L L L L H L	L 1
		L L L L L L L	L L L L L L L	L L L L L H L	L 2
		⋮	⋮	⋮	L3... L60
	Light	L L L L L L L	L L L L L L L	H H H H L H H	L61
		L L L L L L L	L L L L L L L	H H H H H L L	L62
	Blue	L L L L L L L	L L L L L L L	H H H H H H H	Blue L63
Gray Scale of White & Black	Black	L L L L L L L	L L L L L L L	L L L L L L L	L 0
	Dark ↑ ↓ Light	L L L L L H L	L L L L L H L	L L L L L H L	L 1
		L L L L L L L	L L L L L H L	L L L L L H L	L 2
		⋮	⋮	⋮	L3... L60
	Light	H H H H L H H	H H H H L H H	H H H H L H H	L61
		H H H H H L L	H H H H H L L	H H H H H L L	L62
	White	H H H H H H H	H H H H H H H	H H H H H H H	White L63

**FOR SAFETY**

LCD module is generally designed with precise parts to achieve light weighted thin mechanical dimensions.

In using our Modules, make certain that you fully understand and put into practice the warnings and safety precautions detailed in Engineering Information No.EE-N001,"CAUTIONS AND INSTRUCTIONS FOR TOSHIBA MATSUSHITA DISPLAY TECHNOLOGY CO.,LTD LCD MODULES".

Refer to individual specifications and TECHNICAL DATA sheets (hereinafter called "TD") for more detailed technical information.

1) SPECIAL PURPOSES

A) Toshiba Matsushita Display technology Co.,Ltd's Standard LCD Modules have not been customized for operation in extreme environments or for use in applications where performance failures could be life-threatening or otherwise catastrophic.

B) Since Toshiba Matsushita Display technology Co.,Ltd's Standard LCD Modules have not been designed for operation in extreme environments, they must never be used in devices that will be exposed to abnormally high levels of vibration or shock which exceed Toshiba Matsushita Display technology Co.,Ltd's published specification limits.

C) In addition, since Toshiba Matsushita Display technology Co.,Ltd Standard LCD Modules have not been designed for use in applications where performance failures could be life-threatening or catastrophic, they must never be installed in aircraft navigation control systems (such as, but not limited to Traffic Collision Avoidance System and Air Traffic Indicator), in military defense or weapons systems, in critical industrial process-control systems (e.g., those involved in the production of nuclear energy), or in critical medical device or patient life-support systems.

2) DISASSEMBLING OR MODIFICATION

DO NOT DISASSEMBLE OR MODIFY the module. It may damage sensitive parts inside LCD module, and may cause scratches or dust on the display.

Toshiba Matsushita Display technology Co.,Ltd does not warrant the module, if customer disassembled or modified it.

3) BREAKAGE OF LCD PANEL

DO NOT INGEST liquid crystal material, DO NOT INHALE this material, and DO NOT CONTACT the material with skin, if LCD panel is broken and liquid crystal material spills out.

If liquid crystal material comes into mouth or eyes, rinse mouth or eyes out with water immediately.

If this material contact with skin or cloths, wash it off immediately with alcohol and rinse thoroughly with water.

4) GLASS OF LCD PANEL

BE CAREFUL WITH CHIPS OF GLASS that may cause injuring fingers or skin, when the glass is broken.

5) ELECTRIC SHOCK

DISCONNECT POWER SUPPLY before handling LCD module.

DO NOT TOUCH the parts inside LCD module and the fluorescent lamp's connector or cables in order to prevent electric shock, because high voltage is supplied to these parts from the inverter unit while power supply is turned on.

6) ABSOLUTE MAXIMUM RATINGS AND POWER PROTECTION CIRCUIT

DO NOT EXCEED the absolute maximum rating values under the worst probable conditions caused by the supply voltage variation, input voltage variation, variation in parts' constants, environmental temperature, etc., otherwise LCD module may be damaged.

Employ protection circuit for power supply, whenever the specification or TD specifies it.

Suitable protection circuit should be applied for each system design.

7) DISPOSAL

When dispose LCD module, obey to the applicable environmental regulations.