



Chipsmall Limited consists of a professional team with an average of over 10 year of expertise in the distribution of electronic components. Based in Hongkong, we have already established firm and mutual-benefit business relationships with customers from,Europe,America and south Asia,supplying obsolete and hard-to-find components to meet their specific needs.

With the principle of "Quality Parts,Customers Priority,Honest Operation,and Considerate Service",our business mainly focus on the distribution of electronic components. Line cards we deal with include Microchip,ALPS,ROHM,Xilinx,Pulse,ON,Everlight and Freescale. Main products comprise IC,Modules,Potentiometer,IC Socket,Relay,Connector.Our parts cover such applications as commercial,industrial, and automotives areas.

We are looking forward to setting up business relationship with you and hope to provide you with the best service and solution. Let us make a better world for our industry!



## Contact us

Tel: +86-755-8981 8866 Fax: +86-755-8427 6832

Email & Skype: info@chipsmall.com Web: www.chipsmall.com

Address: A1208, Overseas Decoration Building, #122 Zhenhua RD., Futian, Shenzhen, China



All information is subject to change without notice. Please read bottom notes.

**FEATURES:**(1)8.5"W- VGA color display with High Luminance (215cd/m<sup>2</sup>@6.0mA)  
 (2)Built in Long Life Lamps (30,000h@6.0mA, 50,000h@5.0mA)  
 (3)Assembled with Touch Panel(4 wired resistance type, except controller)

**TENTATIVE**

**RoHS compatible**

### MECHANICAL SPECIFICATIONS

Item	Specifications
Dimensional Outline (typ.)	224.0(W*) x 135.0(H) x 13.8max(D) mm *Including 4 Mounting Lugs
Number of Pixels	800(W) x 480(H) pixels
Active Area	184.8(W) x 110.88(H) mm
Pixel Pitch	0.231(W) x 0.231(H)
Weight (approximately)	500g
Backlight	Single CCFL(L-type), Sidelight type

### ABSOLUTE MAXIMUM RATINGS

Item	Min.	Max.	Unit	
Supply Voltage	(V <sub>DD</sub> )	-0.3	4.0	V
	(V <sub>FL</sub> )	---	2.0	kV(rms)
FL Driving Frequency (f <sub>FL</sub> )	---	80	kHz	
Input Signal Voltage (V <sub>IN</sub> )	-0.3	3.6	V	
Operating Temperature (Note)	-20	70	°C	
Storage Temperature	-30	80	°C	
Storage Humidity (Max. wet bulb temperature = 39°C)	10	90	%(RH)	

Note) Only operation is guaranteed at Operating Temperature. Display quality is evaluated at +25°C.

### ELECTRICAL SPECIFICATION (T<sub>a</sub>=25°C) (RECOMMENDED OPERATION CONDITION)

Item	Min.	Typ.	Max.	Unit	Remarks	
Supply Voltage	(V <sub>DD</sub> )	3.15	3.3	3.45	V	V <sub>DD</sub> :3.3V
	(V <sub>FL</sub> )	---	(660)	---	V(rms)	
FL Start Voltage	(1600)	---	---	V(rms)	T <sub>a</sub> =0°C	
High Level Input Voltage (V <sub>IH</sub> )	0.7 V <sub>DD</sub>	---	V <sub>DD</sub>			
Low Level Input Voltage (V <sub>IL</sub> )	0	---	0.3 V <sub>DD</sub>	V		
Current Consumption	*1 (I <sub>DD</sub> )	---	150	245	mA	
	*2 (I <sub>FL</sub> )	4.0	6.0	7.0	mA(rms)	
*1*2 Power Consumption	---	4.46	---	W	I <sub>FL</sub> =6.0mA(rms) V <sub>DD</sub> :3.3V	

\*1 : 8 color bars pattern

\*2 : Except the efficiency of FL inverter

### OPTICAL SPECIFICATION (T<sub>a</sub>=25°C)

Item	Min.	Typ.	Max.	Unit	Remarks
Contrast Ratio (CR)	100	250	---	---	
Viewing Angle (CR ≥ 10)	(Upper+Lower)	---	100	---	°
	(Left+Right)	---	120	---	°
Response Time	(τ <sub>r</sub> )	---	---	50	ms
	(τ <sub>f</sub> )	---	---	50	ms
Luminance	170	215	---	cd/m <sup>2</sup>	I <sub>FL</sub> =6.0mA(rms)
	160	200	---	cd/m <sup>2</sup>	I <sub>FL</sub> =5.0mA(rms)
Lamp Life Time (MTBF)*3 *4	30,000			h	I <sub>FL</sub> =6.0mA(rms)
	50,000			h	I <sub>FL</sub> =5.0mA(rms)

\*3 : Conditions ; T<sub>a</sub>=25°C, I<sub>FL</sub>=6.0mA(rms), continuous lighting

\*4 : Definitions of failure ; 1) Lcd luminance becomes half of the minimum value. 2) Lamp doesn't light normally.

\*The information contained herein is presented only as a guide for the applications of our products. No responsibility is assumed by Toshiba Matsushita Display Technology or other rights of the third parties which may result from its use. No license is granted by implication or otherwise under any patent or patent rights of Toshiba Matsushita Display Technology or others.

\*The information contained herein may be changed without prior notice. It is therefore advisable to contact Toshiba Matsushita Display Technology before proceeding with the design of equipment incorporating this product.

## &lt;Touch Panel Condition&gt;

## Absolute Maximum Rating

Item		Min.	Typ.	Max.	Unit	Remarks
Operating Temperature	$T_{TPOP}$	-20	---	70	°C	
Storage Temperature	$T_{TPST}$	-30	---	80	°C	

## Recommended Operating Conditions

Item		Min.	Typ.	Max.	Unit	Remarks
Supply Voltage	$V_{TP}$	---	5.0	7.0	V	

## Electrical Specifications

Item		Min.	Typ.	Max.	Unit	Remarks	
Insulation Resistance	Z	20	---	---	MOhm	DC25V	
Resistance between Terminals	#1 - #3(X)	$R_x$	200	---	1500	Ohm	Measured at connector pin(including conductor resistance).
	#2 - #4(Y)	$R_y$	100	---	600	Ohm	
Linearity	-		1.0	2.0	%		
Chattering	-			15	msec		

## Mechanical Specifications

Item		Min.	Typ.	Max.	Unit	Remarks
Operating Starting Force	-	0.05	---	0.8	N	
Surface Hardness	-	3			H	
Haze	-	6	8	10	%	

# TENTATIVE

## DIMENSIONAL OUTLINE

(Front)

Unit : mm  
Standard tolerance : ±0.5

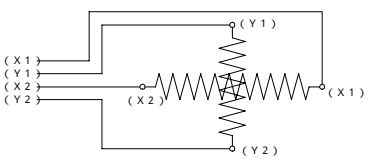
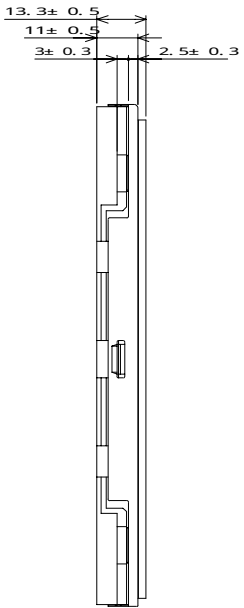
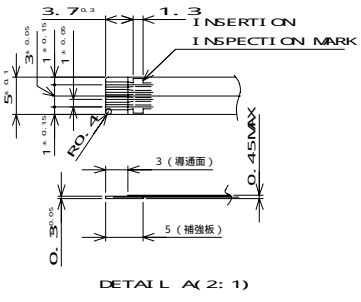
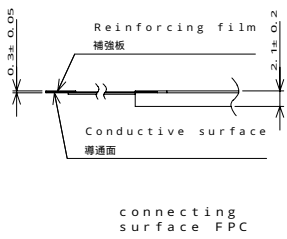
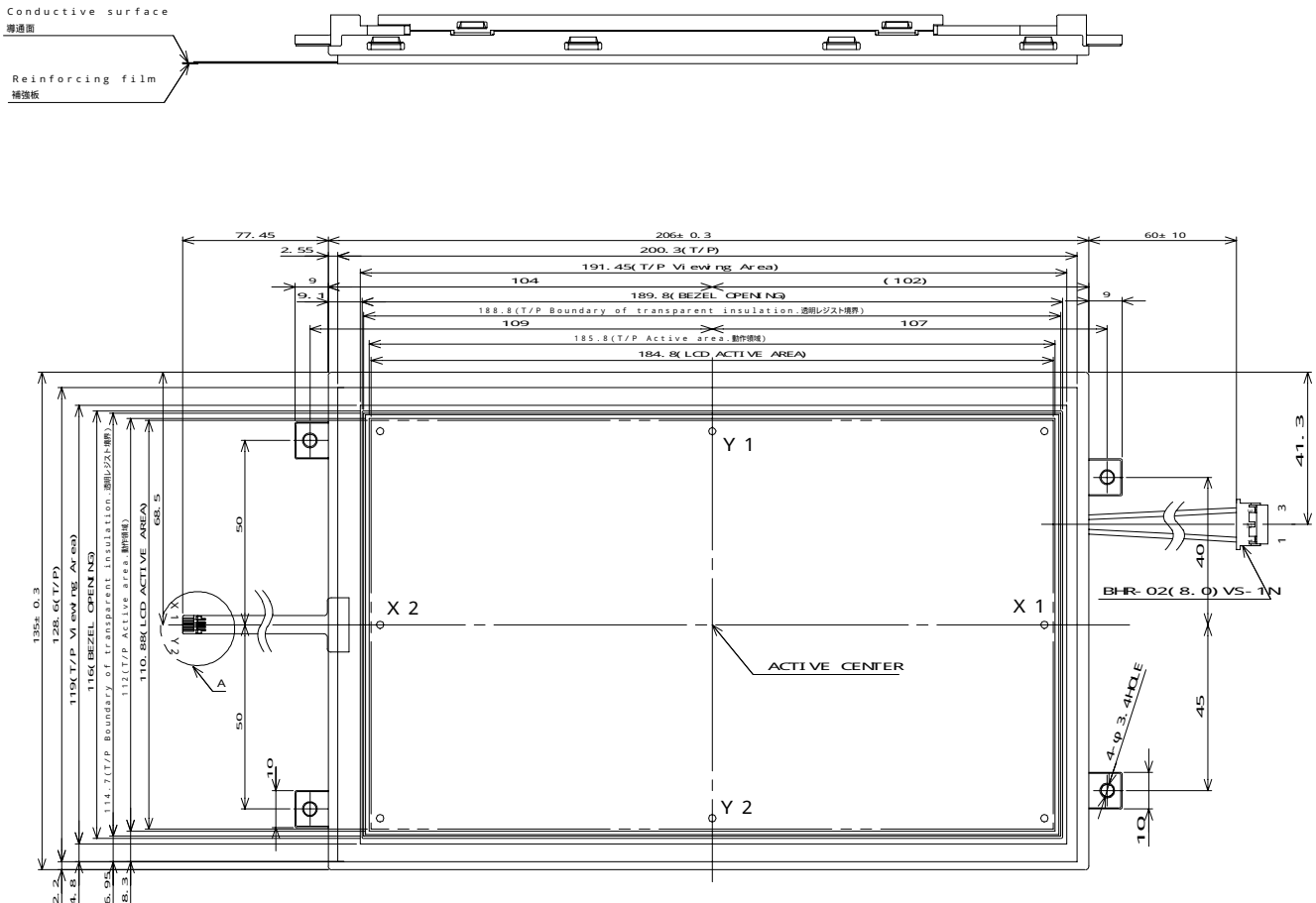

Circuit diagram

Conductive surface  
導通面

Reinforcing film  
補強板

(Rear)

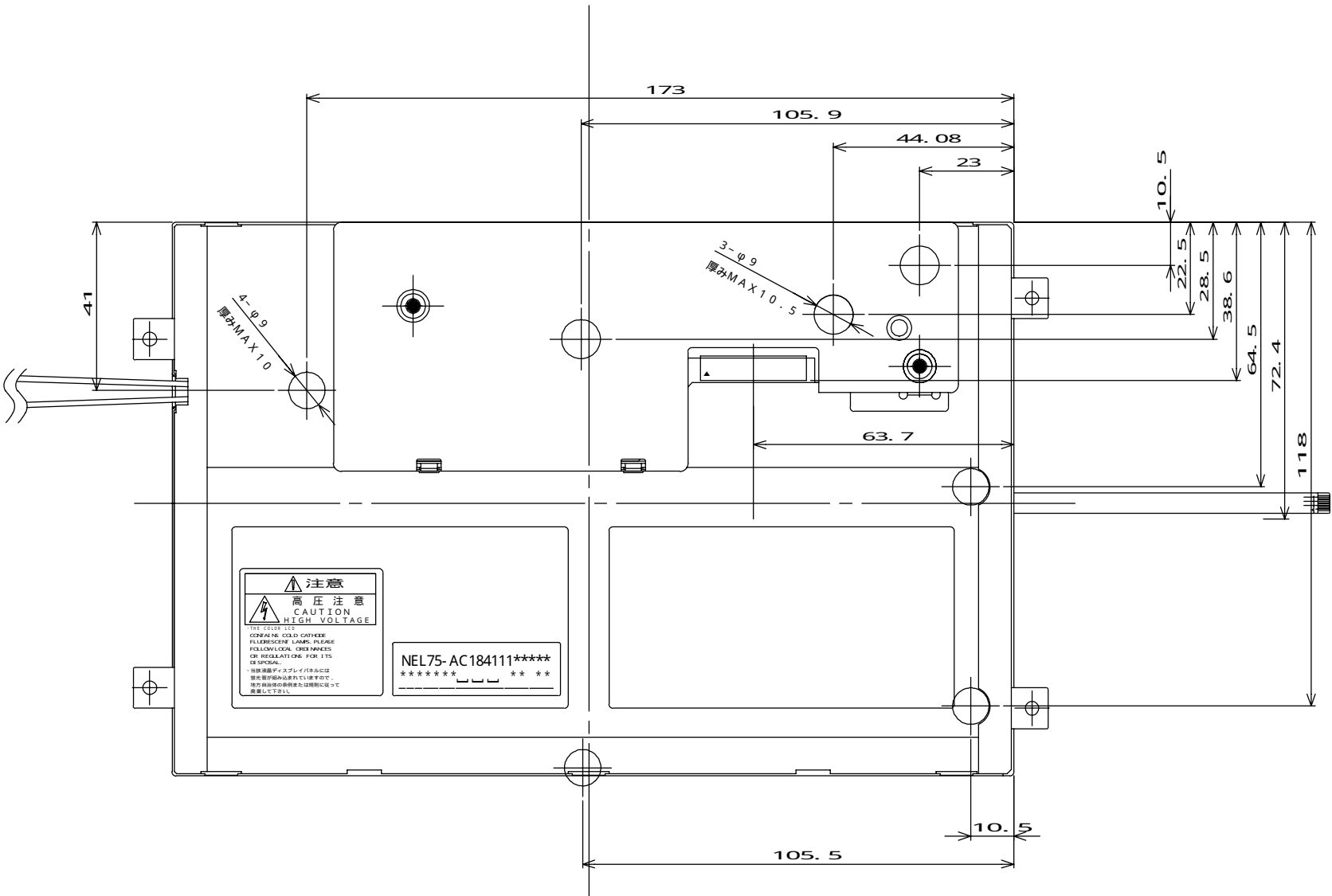

Unit : mm

Standard tolerance : ±0.5

**BLOCK DIAGRAM**

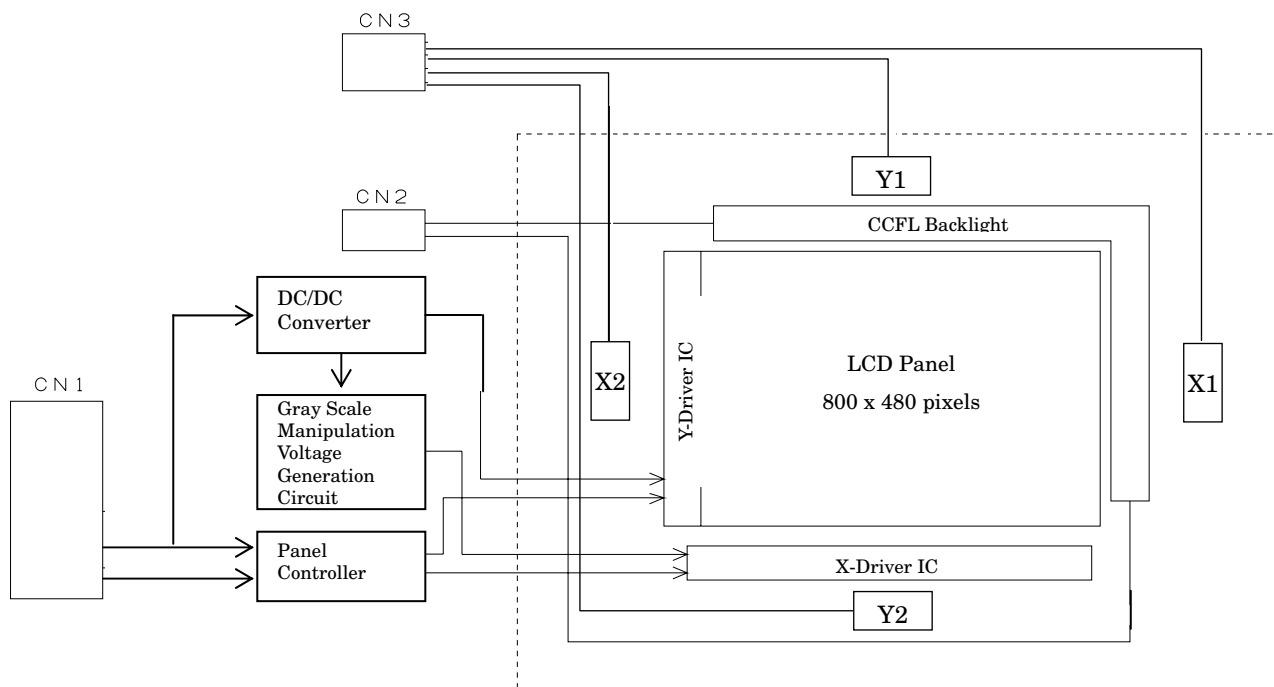

**SEQUENCE OF POWER SUPPLIES AND SIGNALS**

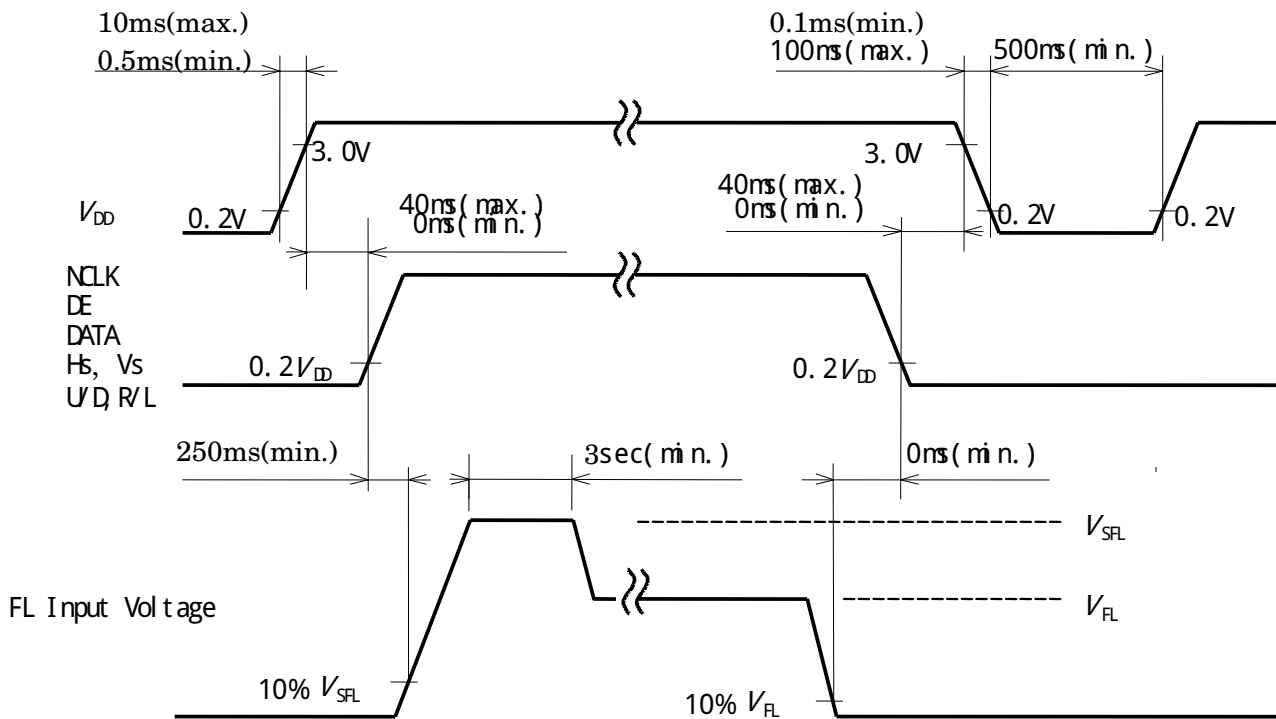

TIMING CHART

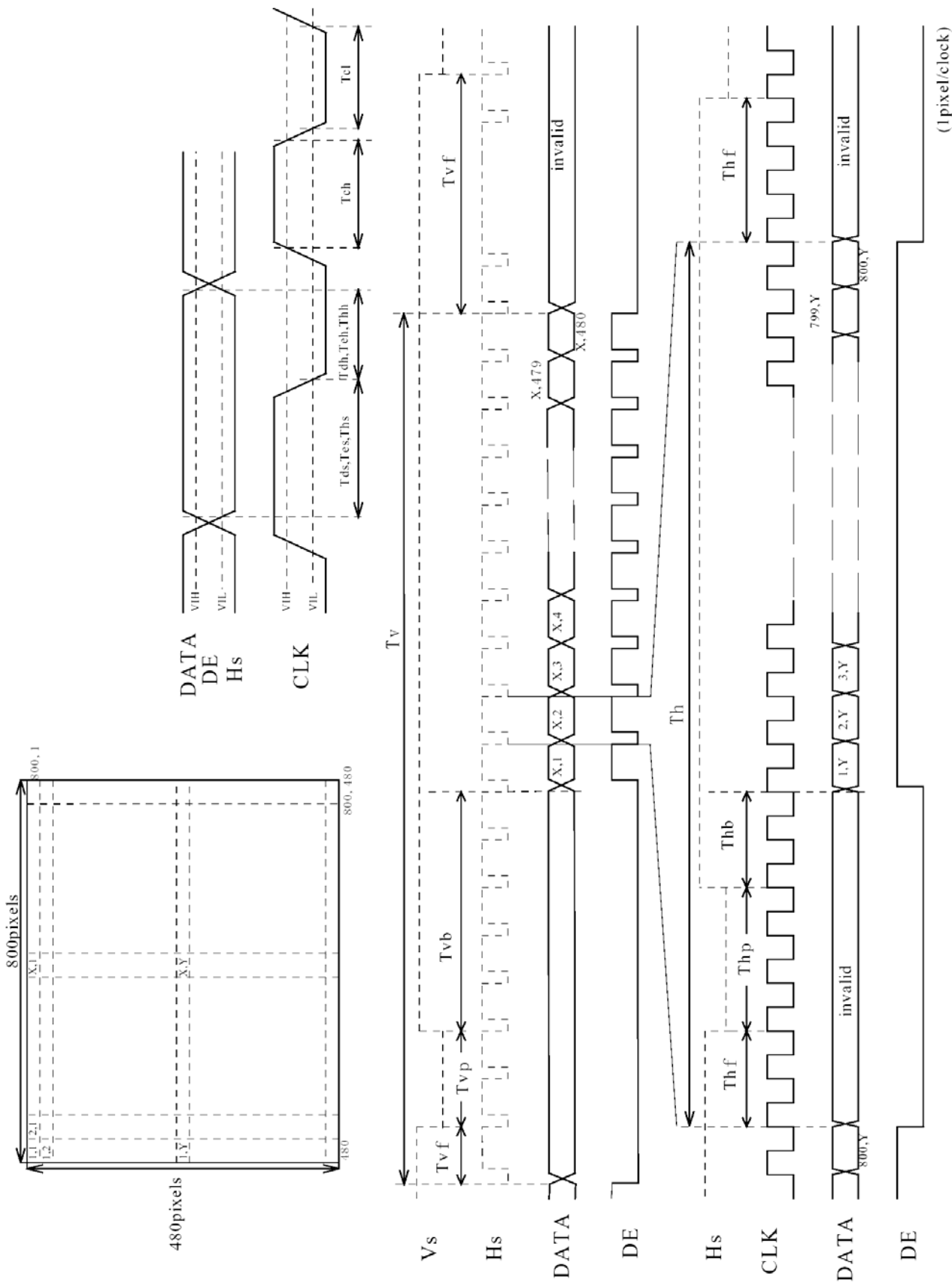

TIMING SPECIFICATION <sup>1) 2) 3) 4) 5) 6)</sup>

Item		Symbol	min.	typ.	max.	unit
CLK Clock	frequency	$F_{ck}$	29.8	33.2	36.5	MHz
	Period	$Clk$	27.4	30.1	33.5	ns
	High Time	$T_{ch}$	10	-	-	ns
	Low time	$T_{cl}$	10	-	-	ns
DATA Data	Setup Time	$T_{ds}$	5	-	-	ns
	Hold Time	$T_{dh}$	10	-	-	ns
DE Data Enable	Setup Time	$T_{ds}$	5	-	-	ns
	Hold Time	$T_{dh}$	10	-	-	ns
HS Horizontal Sync	Setup Time	$T_{hs}$	5	-	-	ns
	Hold Time	$T_{hh}$	10	-	-	ns
	Period	$Th$	944	1056	1088	(Clk)
			-	31.8	-	us
	Pulse Width	$Thp$	4	128	-	(Clk)
	Front Porch	$Thf$	-	40	-	(Clk)
	Back Porch	$Thb$	7	88	-	(Clk)
V S Vertical Sync	Period	$Tv$	516	525	534	(Th)
			14.7	16.6	17.4	ms
	Pulse Width	$Tvp$	1	2	-	(Th)
	Front Porch	$Tvf$	-	11	-	(Th)
	Back Porch	$Tvb$	4	32	-	(Th)

Note 1) If NCLK is fixed to "H" or "L" level for certain period while DE is supplied, the panel may be damaged.

Note 2) Please adjust LCD operating signal timing and FL driving frequency, to optimize the display quality.

There is a possibility that flicker is observed by the interference of LCD operating signal timing and FL driving condition (especially driving frequency), even if the condition satisfies above timing specifications.

Note3 ) Do not make  $t_v$ ,  $t_h$  and  $t_{hp}$  fluctuate.

Note4) In case of using the long frame period, the deterioration of display quality, noise etc. may be occurred.

Note5) NCLK count of each Horizontal Scanning Time should be always the same.

V-Blanking period should be " $n$ " X "Horizontal Scanning Time". ( $n$ : integer)

Frame period should be always the same.



**CONNECTOR PIN ASSIGNMENT FOR INTERFACE**CN1 INPUT SIGNAL

Connector : IMSA-9637S-40S-GF (0.5mm pitch, Bottom Contact Type) / IRISO ELECTRICS CO., LTD.

Terminal No.	Symbol	Function
1	GND	
2	GND	
3	CLK	CLOCK
4	GND	
5	GND	
6	NC	
7	R0	RED DISPLAY DATA (LSB)
8	R1	RED DISPLAY DATA
9	R2	RED DISPLAY DATA
10	GND	
11	R3	RED DISPLAY DATA
12	R4	RED DISPLAY DATA
13	R5	RED DISPLAY DATA (MSB)
14	GND	
15	G0	GREEN DISPLAY DATA (LSB)
16	G1	GREEN DISPLAY DATA
17	G2	GREEN DISPLAY DATA
18	GND	
19	G3	GREEN DISPLAY DATA
20	G4	GREEN DISPLAY DATA
21	G5	GREEN DISPLAY DATA (MSB)
22	GND	
23	B0	BLUE DISPLAY DATA (LSB)
24	B1	BLUE DISPLAY DATA
25	B2	BLUE DISPLAY DATA
26	GND	
27	B3	BLUE DISPLAY DATA
28	B4	BLUE DISPLAY DATA
29	B5	BLUE DISPLAY DATA (MSB)
30	GND	
31	H-sync	HORIZONTAL SYNC.
32	GND	
33	V-sync	VERTICAL SYNC.
34	NC	
35	DE	DATA ENABLE
36	NC	
37	VDD	+3.3V POWER SUPPLY
38	VDD	+3.3V POWER SUPPLY
39	VDD	+3.3V POWER SUPPLY
40	VDD	+3.3V POWER SUPPLY

CN2 CCFL POWER SOURCE

Connector : BHR-02(8.0)VS-1N / JAPAN SOLDERLESS TERMINAL MFG CO., LTD.

Mating Connector : SM02(8.0)B-BHS-1N-TB / JAPAN SOLDERLESS TERMINAL MFG CO., LTD.

Terminal No.	Symbol	Function
1	VFLH	CCFL Power Supply (high voltage)
2	VFLL	CCFL Power Supply (low voltage)

Note 1) NC terminal should be open.

CN3 4WIRED TOUCH PANEL SIGNAL

Connector : FPC 1mm pitch

Mating Connector :FC1S004HA1 / JAE

Terminal No.	Symbol	Function
1	X1	RIGHT
2	Y1	TOP
3	X2	LEFT
4	Y2	BOTTOM

## 256k (k=1024) COLORS COMBINATION TABLE

	Display	R5 R4 R3 R2 R1 R0	G5 G4 G3 G2 G1 G0	B5 B4 B3 B2 B1 B0	Gray Scale Level
Basic Color	Black	L L L L L L	L L L L L L	L L L L L L	-
	Blue	L L L L L L	L L L L L L	H H H H H H	-
	Green	L L L L L L	H H H H H H	L L L L L L	-
	Light Blue	L L L L L L	H H H H H H	H H H H H H	-
	Red	H H H H H H	L L L L L L	L L L L L L	-
	Purple	H H H H H H	L L L L L L	H H H H H H	-
	Yellow	H H H H H H	H H H H H H	L L L L L L	-
	White	H H H H H H	H H H H H H	H H H H H H	-
Gray Scale of Red	Black	L L L L L L	L L L L L L	L L L L L L	L 0
	Dark ↑ ↓ Light	L L L L L H	L L L L L L	L L L L L L	L 1
		L L L L H L	L L L L L L	L L L L L L	L 2
		⋮	⋮	⋮	L3... L60
		H H H H L H	L L L L L L	L L L L L L	L61
	H H H H H L	L L L L L L	L L L L L L	L62	
Red	H H H H H H	L L L L L L	L L L L L L	Red L63	
Gray Scale of Green	Black	L L L L L L	L L L L L L	L L L L L L	L 0
	Dark ↑ ↓ Light	L L L L L L	L L L L L H	L L L L L L	L 1
		L L L L L L	L L L L H L	L L L L L L	L 2
		⋮	⋮	⋮	L3... L60
		L L L L L L	H H H H L H	L L L L L L	L61
	L L L L L L	H H H H H L	L L L L L L	L62	
Green	L L L L L L	H H H H H H	L L L L L L	Green L63	
Gray Scale of Blue	Black	L L L L L L	L L L L L L	L L L L L L	L 0
	Dark ↑ ↓ Light	L L L L L L	L L L L L L	L L L L L H	L 1
		L L L L L L	L L L L L L	L L L L H L	L 2
		⋮	⋮	⋮	L3... L60
		L L L L L L	L L L L L L	H H H H L H	L61
	L L L L L L	L L L L L L	H H H H H L	L62	
Blue	L L L L L L	L L L L L L	H H H H H H	Blue L63	
Gray Scale of White & Black	Black	L L L L L L	L L L L L L	L L L L L L	L 0
	Dark ↑ ↓ Light	L L L L L H	L L L L L H	L L L L L H	L 1
		L L L L H L	L L L L H L	L L L L H L	L 2
		⋮	⋮	⋮	L3... L60
		H H H H L H	H H H H L H	H H H H L H	L61
	H H H H H L	H H H H H L	H H H H H L	L62	
White	H H H H H H	H H H H H H	H H H H H H	White L63	



## FOR SAFETY

LCD module is generally designed with precise parts to achieve light weighted thin mechanical dimensions.

In using our Modules, make certain that you fully understand and put into practice the warnings and safety precautions detailed in Engineering Information No.EE-N001,"CAUTIONS AND INSTRUCTIONS FOR TOSHIBA LCD MODULES".

Refer to individual specifications and TECHNICAL DATA sheets (hereinafter called "TD") for more detailed technical information.

### 1) SPECIAL PURPOSES

A) Toshiba Matsushita Display Technology's Standard LCD Modules have not been customized for operation in extreme environments or for use in applications where performance failures could be life-threatening or otherwise catastrophic.

B) Since Toshiba Matsushita Display Technology's Standard LCD Modules have not been designed for operation in extreme environments, they must never be used in devices that will be exposed to abnormally high levels of vibration or shock which exceed Toshiba Matsushita Display Technology's published specification limits.

C) In addition, since Toshiba Matsushita Display Technology Standard LCD Modules have not been designed for use in applications where performance failures could be life-threatening or catastrophic, they must never be installed in aircraft navigation control systems (such as, but not limited to Traffic Collision Avoidance System and Air Traffic Indicator), in military defense or weapons systems, in critical industrial process-control systems (e.g., those involved in the production of nuclear energy), or in critical medical device or patient life-support systems.

### 2) DISASSEMBLING OR MODIFICATION

DO NOT DISASSEMBLE OR MODIFY the module. It may damage sensitive parts inside LCD module, and may cause scratches or dust on the display.

Toshiba Matsushita Display Technology does not warrant the module, if customer disassembled or modified it.

### 3) BREAKAGE OF LCD PANEL

DO NOT INGEST liquid crystal material, DO NOT INHALE this material, and DO NOT CONTACT the material with skin, if LCD panel is broken and liquid crystal material spills out.

If liquid crystal material comes into mouth or eyes, rinse mouth or eyes out with water immediately.

If this material contact with skin or cloths, wash it off immediately with alcohol and rinse thoroughly with water.

### 4) GLASS OF LCD PANEL

BE CAREFUL WITH CHIPS OF GLASS that may cause injuring fingers or skin, when the glass is broken.

### 5) ELECTRIC SHOCK

DISCONNECT POWER SUPPLY before handling LCD module.

DO NOT TOUCH the parts inside LCD module and the fluorescent lamp's connector or cables in order to prevent electric shock, because high voltage is supplied to these parts from the inverter unit while power supply is turned on.

### 6) ABSOLUTE MAXIMUM RATINGS AND POWER PROTECTION CIRCUIT

DO NOT EXCEED the absolute maximum rating values under the worst probable conditions caused by the supply voltage variation, input voltage variation, variation in parts' constants, environmental temperature, etc., otherwise LCD module may be damaged.

Employ protection circuit for power supply, whenever the specification or TD specifies it.

Suitable protection circuit should be applied for each system design.

### 7) RECOMMENDED OPERATION CONDITIONS

The performance and quality of the LCD panel are warranted only when the LCD panel is used within "the recommended operation conditions". Toshiba Matsushita Display Technology Co., Ltd. never warrants the performance and quality of the LCD panel when you use the LCD panel over "the recommended operation conditions", although within "the absolute maximum rating".

To use the LCD panel over "the recommended operation conditions" may have bad influence on the characteristics and reliability of the LCD panel and may shorten the life of the LCD panel.

Therefore, when designing the whole set, not to be over "the recommended operation conditions", you should fully take care of supply voltage change, characteristic of connection parts, surge of input-and-output line, and surrounding temperature.

### 8) DISPOSAL

When dispose LCD module, obey to the applicable environmental regulations.