



Chipsmall Limited consists of a professional team with an average of over 10 year of expertise in the distribution of electronic components. Based in Hongkong, we have already established firm and mutual-benefit business relationships with customers from,Europe,America and south Asia,supplying obsolete and hard-to-find components to meet their specific needs.

With the principle of “Quality Parts,Customers Priority,Honest Operation,and Considerate Service”,our business mainly focus on the distribution of electronic components. Line cards we deal with include Microchip,ALPS,ROHM,Xilinx,Pulse,ON,Everlight and Freescale. Main products comprise IC,Modules,Potentiometer,IC Socket,Relay,Connector.Our parts cover such applications as commercial,industrial, and automotives areas.

We are looking forward to setting up business relationship with you and hope to provide you with the best service and solution. Let us make a better world for our industry!



Contact us

Tel: +86-755-8981 8866 Fax: +86-755-8427 6832

Email & Skype: info@chipsmall.com Web: www.chipsmall.com

Address: A1208, Overseas Decoration Building, #122 Zhenhua RD., Futian, Shenzhen, China



High Power Step-Down Switching Regulator Controller

FEATURES

- **High Power 5V to 3.xV Switching Controller: Can Exceed 10A Output**
- **All N-Channel External MOSFETs**
- Constant Frequency Operation—Small Inductor
- **Excellent Output Regulation: $\pm 1\%$ Over Line, Load and Temperature Variations**
- High Efficiency: Over 95% Possible
- Fixed Frequency Operation
- No Low Value Sense Resistor Needed
- Outputs Can Drive External FETs with Up to 10,000pF Gate Capacitance
- Quiescent Current: 350 μ A Typ, 1 μ A in Shutdown
- Fast Transient Response
- Adjustable or Fixed 3.3V Output
- Available in 8- and 16-Lead PDIP and SO Packages

APPLICATIONS

- Power Supply for P6 and Pentium[®] Microprocessors
- High Power 5V to 3.xV Regulators
- Local Regulation for Dual Voltage Logic Boards
- Low Voltage, High Current Battery Regulation

DESCRIPTION

The LTC[®]1430 is a high power, high efficiency switching regulator controller optimized for 5V to 3.xV applications. It includes a precision internal reference and an internal feedback system that can provide output regulation of $\pm 1\%$ over temperature, load current and line voltage shifts. The LTC1430 uses a synchronous switching architecture with two N-channel output devices, eliminating the need for a high power, high cost P-channel device. Additionally, it senses output current across the drain-source resistance of the upper N-channel FET, providing an adjustable current limit without an external low value sense resistor.

The LTC1430 includes a fixed frequency PWM oscillator for low output ripple under virtually all operating conditions. The 200kHz free-running clock frequency can be externally adjusted from 100kHz to above 500kHz. The LTC1430 features low 350 μ A quiescent current, allowing greater than 90% efficiency operation in converter designs from 1A to greater than 50A output current. Shutdown mode drops the LTC1430 supply current to 1 μ A. **For new designs, refer to the LTC3830.**

LT, LTC and LT are registered trademarks of Linear Technology Corporation. Pentium is a registered trademark of Intel Corporation.

TYPICAL APPLICATION

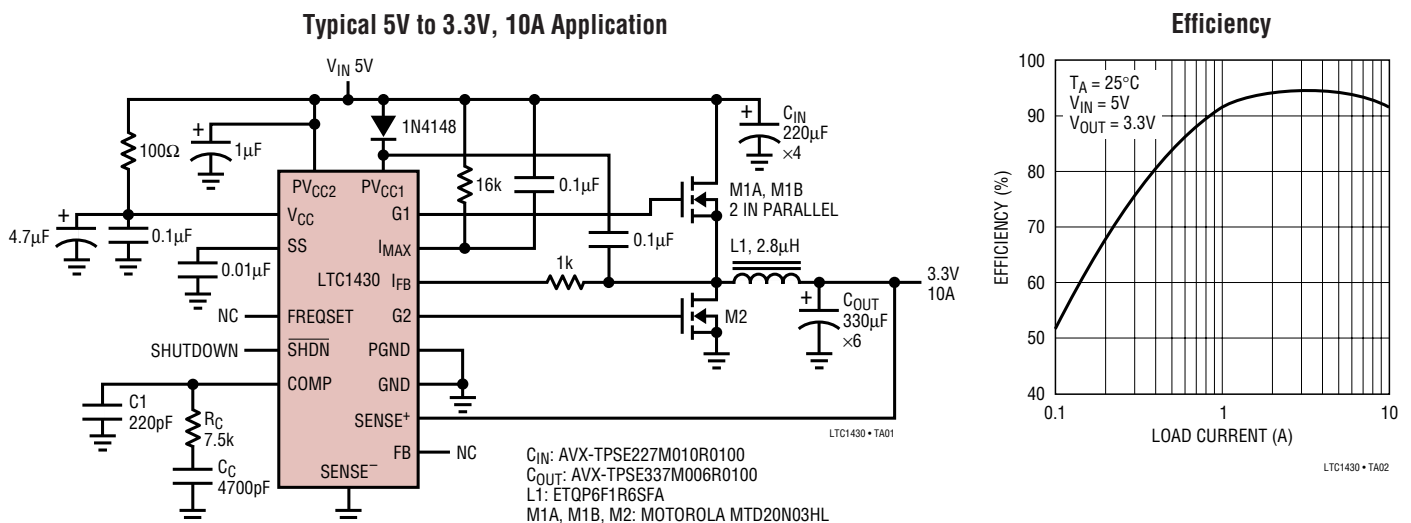

LTC1430

ABSOLUTE MAXIMUM RATINGS (Note 1)

Supply Voltage	Operating Temperature Range
V_{CC} 9V	LTC1430C 0°C to 70°C
$PV_{CC1,2}$ 13V	LTC1430I -40°C to 85°C
Input Voltage	Storage Temperature Range -65°C to 150°C
I_{FB} -0.3V to 18V	Lead Temperature (Soldering, 10 sec) 300°C
All Other Inputs -0.3V to ($V_{CC} + 0.3V$)	

PACKAGE/ORDER INFORMATION

<p>N8 PACKAGE 8-LEAD PDIP</p> <p>S8 PACKAGE 8-LEAD PLASTIC SO</p> <p>$T_{JMAX} = 150^{\circ}C, \theta_{JA} = 100^{\circ}C/W$ (N8) $T_{JMAX} = 150^{\circ}C, \theta_{JA} = 150^{\circ}C/W$ (S8)</p>	ORDER PART NUMBER	<p>N PACKAGE 16-LEAD PDIP</p> <p>S PACKAGE 16-LEAD PLASTIC SO</p> <p>$T_{JMAX} = 150^{\circ}C, \theta_{JA} = 70^{\circ}C/W$ (N) $T_{JMAX} = 150^{\circ}C, \theta_{JA} = 110^{\circ}C/W$ (S)</p>	ORDER PART NUMBER
	LTC1430CN8 LTC1430CS8		LTC1430CN LTC1430CS LTC1430IS
	S8 PART MARKING		
	1430		

Consult factory for Industrial and Military grade parts.

ELECTRICAL CHARACTERISTICS

The ● denotes the specifications which apply over the full operating temperature range, otherwise specifications are at $T_A = 25^{\circ}C$. $V_{CC} = 5V$ unless otherwise noted. (Note 2)

SYMBOL	PARAMETER	CONDITIONS	MIN	TYP	MAX	UNITS	
V_{CC}	Supply Voltage		●	4	8	V	
PV_{CC}	PV_{CC1}, PV_{CC2}		●		13	V	
V_{OUT}	Output Voltage	Figure 1	●	3.30		V	
V_{FB}	Feedback Voltage	Figure 1, SENSE+ and SENSE- Floating (LTC1430C)	●	1.25	1.265	1.28	V
		Figure 1, SENSE+ and SENSE- Floating (LTC1430I)	●	1.23	1.265	1.29	V
ΔV_{OUT}	Output Load Regulation	Figure 1, $I_{OUT} = 0A$ to 10A (Note 3) (LTC1430C)	●	5	20	mV	
		Figure 1, $I_{OUT} = 0A$ to 10A (Note 3) (LTC1430I)		5		mV	
	Output Line Regulation	Figure 1, $V_{CC} = 4.75V$ to 5.25V (Note 3) (LTC1430C)	●	1	5	mV	
		Figure 1, $V_{CC} = 4.75V$ to 5.25V (Note 3) (LTC1430I)		1		mV	
I_{VCC}	Supply Current (V_{CC} Only)	Figure 2, $V_{SHDN} = V_{CC}$	●	350	700	μA	
		$V_{SHDN} = 0V$		1	10	μA	
I_{PVCC}	Supply Current (PV_{CC})	Figure 2, $PV_{CC} = 5V, V_{SHDN} = V_{CC}$ (Note 4)		1.5		mA	
		$V_{SHDN} = 0V$		0.1		μA	
f_{OSC}	Internal Oscillator Frequency	FREQSET Floating (LTC1430C)	●	140	200	260	kHz
		FREQSET Floating (LTC1430I)	●	130	200	300	kHz

ELECTRICAL CHARACTERISTICS

The ● denotes the specifications which apply over the full operating temperature range, otherwise specifications are at $T_A = 25^\circ\text{C}$. $V_{CC} = 5\text{V}$ unless otherwise noted. (Note 2)

SYMBOL	PARAMETER	CONDITIONS	MIN	TYP	MAX	UNITS	
V_{IH}	SHDN Input High Voltage		●	2.4		V	
V_{IL}	SHDN Input Low Voltage		●		0.8	V	
I_{IN}	SHDN Input Current		●	± 0.1	± 1	μA	
A_V	Error Amplifier Open-Loop DC Gain	(LTC1430I)	●	40	48	dB	
g_{mV}	Error Amplifier Transconductance	(LTC1430C) (LTC1430I)	●	300	650 650	μMho μMho	
g_{mI}	I_{LIM} Amplifier Transconductance	(Note 5)			1300	μMho	
I_{MAX}	I_{MAX} Sink Current	$V_{I(MAX)} = V_{CC}$ (LTC1430C)	●	8	12	16	μA
		$V_{I(MAX)} = V_{CC}$ (LTC1430I)	●	8	12	17	μA
I_{SS}	Soft-Start Source Current	$V_{SS} = 0$ (LTC1430C)	●	-8	-12	-16	μA
		$V_{SS} = 0$ (LTC1430I)	●	-8	-12	-17	μA
t_r, t_s	Driver Rise/Fall Time	Figure 3, $PV_{CC1} = PV_{CC2} = 5\text{V}$			80	250	ns
t_{NOV}	Driver Non-Overlap Time	Figure 3, $PV_{CC1} = PV_{CC2} = 5\text{V}$		25	130	250	ns
DC_{MAX}	Maximum Duty Cycle	$V_{COMP} = V_{CC}$ (LTC1430C)	●		90	96	%
		$V_{COMP} = V_{CC}, V_{FB} = 0$ (LTC1430I)	●		90	96	%
		$V_{COMP} = V_{CC}, V_{FB} = 1.265\text{V}$ (LTC1430I)	●	83	88		%

Note 1: Absolute Maximum Ratings are those values beyond which the life of a device may be impaired.

Note 2: All currents into device pins are positive; all currents out of device pins are negative. All voltages are referenced to ground unless otherwise specified.

Note 3: This parameter is guaranteed by correlation and is not tested directly.

Note 4: Supply current in normal operation is dominated by the current needed to charge and discharge the external FET gates. This will vary with the LTC1430 operating frequency, operating voltage and the external FETs used.

Note 5: The I_{LIM} amplifier can sink but cannot source current. Under normal (not current limited) operation, the I_{LIM} output current will be zero.

PIN FUNCTIONS (16-Lead Package/8-Lead Package)

G1 (Pin 1/Pin 1): Driver Output 1. Connect this pin to the gate of the upper N-channel MOSFET, M1. This output will swing from PV_{CC1} to PGND. It will always be low when G2 is high.

PV_{CC1} (Pin 2/Pin 2): Power V_{CC} for Driver 1. This is the power supply input for G1. G1 will swing from PGND to PV_{CC1} . PV_{CC1} must be connected to a potential of at least $PV_{CC} + V_{GS(ON)}(M1)$. This potential can be generated using an external supply or a simple charge pump connected to the switching node between the upper MOSFET and the lower MOSFET; see Applications Information for details.

PGND (Pin 3/Pin 3): Power Ground. Both drivers return to this pin. It should be connected to a low impedance ground in close proximity to the source of M2. 8-lead parts have PGND and GND tied together at pin 3.

GND (Pin 4/Pin 3): Signal Ground. All low power internal circuitry returns to this pin. To minimize regulation errors due to ground currents, GND should be connected to PGND right at the LTC1430. 8-lead parts have PGND and GND tied together internally at pin 3.

SENSE⁻, FB, SENSE⁺ (Pins 5, 6, 7/Pin 4): These three pins connect to the internal resistor divider and to the internal feedback node. To use the internal divider to set the output voltage to 3.3V, connect SENSE⁺ to the positive terminal of the output capacitor and SENSE⁻ to the negative terminal. FB should be left floating in applications that use the internal divider. To use an external resistor divider to set the output voltage, float SENSE⁺ and SENSE⁻ and connect the external resistor divider to FB.

SHDN (Pin 8/Pin 5): Shutdown. A TTL compatible low level at SHDN for longer than 50 μ s puts the LTC1430 into shutdown mode. In shutdown, G1 and G2 go low, all internal circuits are disabled and the quiescent current drops to 10 μ A max. A TTL compatible high level at SHDN allows the part to operate normally.

SS (Pin 9/NA): Soft-Start. The SS pin allows an external capacitor to be connected to implement a soft-start function. An external capacitor from SS to ground controls the start-up time and also compensates the current limit loop, allowing the LTC1430 to enter and exit current limit cleanly. See Applications Information for more details.

COMP (Pin 10/Pin 6): External Compensation. The COMP pin is connected directly to the output of the error amplifier and the input of the PWM. An RC network is used at this node to compensate the feedback loop to provide optimum transient response. See Applications Information for compensation details.

FREQSET (Pin 11/NA): Frequency Set. This pin is used to set the free running frequency of the internal oscillator. With the pin floating, the oscillator runs at about 200kHz. A resistor from FREQSET to ground will speed up the oscillator; a resistor to V_{CC} will slow it down. See Applications Information for resistor selection details.

I_{MAX} (Pin 12/NA): Current Limit Set. I_{MAX} sets the threshold for the internal current limit comparator. If I_{FB} drops below I_{MAX} with G1 on, the LTC1430 will go into current limit. I_{MAX} has a 12 μ A pull-down to GND. It can be adjusted with an external resistor to PV_{CC} or an external voltage source.

I_{FB} (Pin 13/NA): Current Limit Sense. Connect to the switched node at the source of M1 and the drain of M2 through a 1k resistor. The 1k resistor is required to prevent voltage transients from damaging I_{FB} . This pin can be taken up to 18V above GND without damage.

V_{CC} (Pin 14/Pin 7): Power Supply. All low power internal circuits draw their supply from this pin. Connect to a clean power supply, separate from the main PV_{CC} supply at the drain of M1. This pin requires a 4.7 μ F bypass capacitor. 8-lead parts have V_{CC} and PV_{CC2} tied together at pin 7 and require a 10 μ F bypass to GND.

PV_{CC2} (Pin 15/Pin 7): Power V_{CC} for Driver 2. This is the power supply input for G2. G2 will swing from GND to PV_{CC2} . PV_{CC2} is usually connected to the main high power supply. The 8-lead parts have V_{CC} and PV_{CC2} tied together at pin 7 and require a 10 μ F bypass to GND.

G2 (Pin 16/Pin 8): Driver Output 2. Connect this pin to the gate of the lower N-channel MOSFET, M2. This output will swing from PV_{CC2} to PGND. It will always be low when G1 is high.

BLOCK DIAGRAM

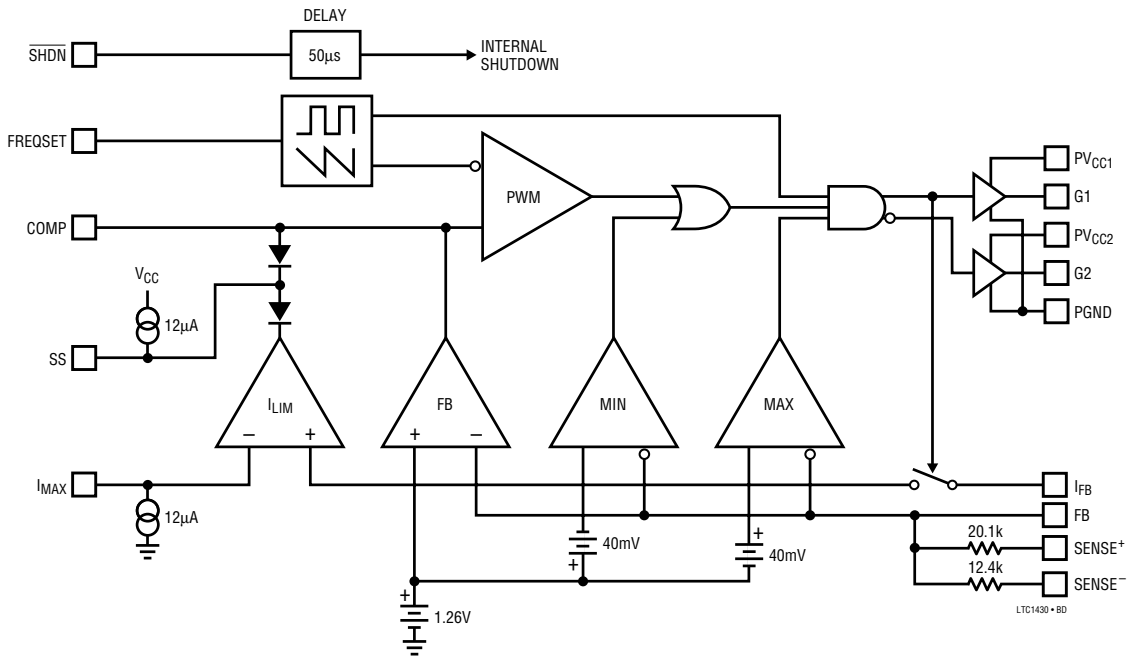

TEST CIRCUITS

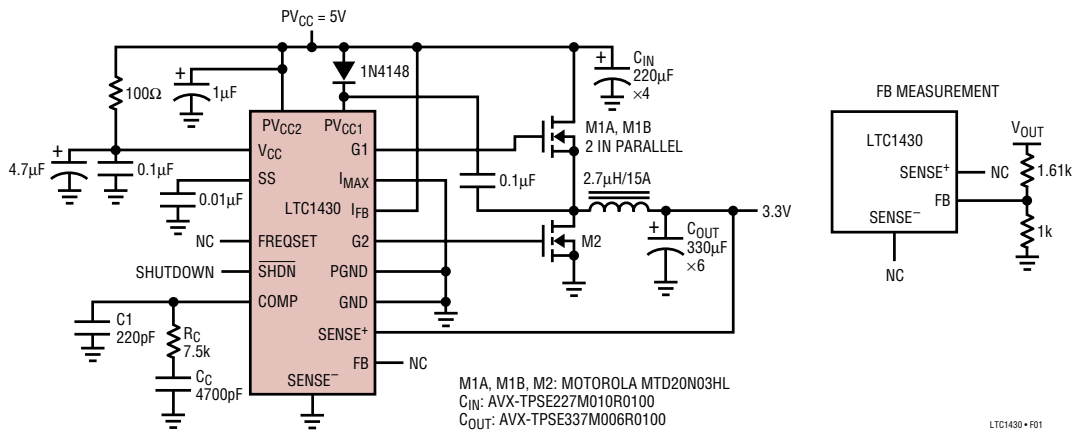

Figure 1

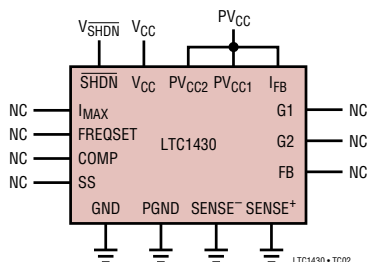

Figure 2

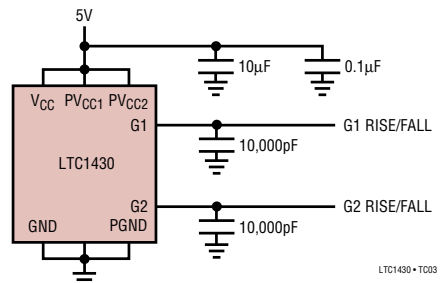

Figure 3

APPLICATIONS INFORMATION

OVERVIEW

The LTC1430 is a voltage feedback PWM switching regulator controller (see Block Diagram) designed for use in high power, low voltage step-down (buck) converters. It includes an onboard PWM generator, a precision reference trimmed to $\pm 0.5\%$, two high power MOSFET gate drivers and all necessary feedback and control circuitry to form a complete switching regulator circuit. The PWM loop nominally runs at 200kHz.

The 16-lead versions of the LTC1430 include a current limit sensing circuit that uses the upper external power MOSFET as a current sensing element, eliminating the need for an external sense resistor.

Also included in the 16-lead version is an internal soft-start feature that requires only a single external capacitor to operate. In addition, 16-lead parts feature an adjustable oscillator which can run at frequencies from 50kHz to beyond 500kHz, allowing added flexibility in external component selection. The 8-lead versions do not include current limit, internal soft-start or frequency adjustability.

THEORY OF OPERATION

Primary Feedback Loop

The LTC1430 senses the output voltage of the circuit at the output capacitor with the SENSE⁺ and SENSE⁻ pins and feeds this voltage back to the internal transconductance amplifier FB. FB compares the resistor-divided output voltage to the internal 1.26V reference and outputs an error signal to the PWM comparator. This is then compared to a fixed frequency sawtooth waveform generated by the internal oscillator to generate a pulse width modulated signal. This PWM signal is fed back to the external MOSFETs through G1 and G2, closing the loop. Loop compensation is achieved with an external compensation network at COMP, the output node of the FB transconductance amplifier.

MIN, MAX Feedback Loops

Two additional comparators in the feedback loop provide high speed fault correction in situations where the FB amplifier may not respond quickly enough. MIN compares the feedback signal to a voltage 40mV (3%) below the

internal reference. At this point, the MIN comparator overrides the FB amplifier and forces the loop to full duty cycle, set by the internal oscillator at about 90%. Similarly, the MAX comparator monitors the output voltage at 3% above the internal reference and forces the output to 0% duty cycle when tripped. These two comparators prevent extreme output perturbations with fast output transients, while allowing the main feedback loop to be optimally compensated for stability.

Current Limit Loop

The 16-lead LTC1430 devices include yet another feedback loop to control operation in current limit. The current limit loop is disabled in 8-lead devices. The I_{LIM} amplifier monitors the voltage drop across external MOSFET M1 with the I_{FB} pin during the portion of the cycle when G1 is high. It compares this voltage to the voltage at the I_{MAX} pin. As the peak current rises, the drop across M1 due to its R_{DS(ON)} increases. When I_{FB} drops below I_{MAX}, indicating that M1's drain current has exceeded the maximum level, I_{LIM} starts to pull current out of the external soft-start capacitor, cutting the duty cycle and controlling the output current level. At the same time, the I_{LIM} comparator generates a signal to disable the MIN comparator to prevent it from conflicting with the current limit circuit. If the internal feedback node drops below about 0.8V, indicating a severe output overload, the circuitry will force the internal oscillator to slow down by a factor of as much as 100. If desired, the turn on time of the current limit loop can be controlled by adjusting the size of the soft-start capacitor, allowing the LTC1430 to withstand short over-current conditions without limiting.

By using the R_{DS(ON)} of M1 to measure the output current, the current limit circuit eliminates the sense resistor that would otherwise be required and minimizes the number of components in the external high current path. Because power MOSFET R_{DS(ON)} is not tightly controlled and varies with temperature, the LTC1430 current limit is not designed to be accurate; it is meant to prevent damage to the power supply circuitry during fault conditions. The actual current level where the limiting circuit begins to take effect may vary from unit to unit, depending on the power MOSFETs used. See Soft-Start and Current Limit for more details on current limit operation.

APPLICATIONS INFORMATION

MOSFET Gate Drive

Gate drive for the top N-channel MOSFET M1 is supplied from PV_{CC1} . This supply must be above PV_{CC} (the main power supply input) by at least one power MOSFET $V_{GS(ON)}$ for efficient operation. An internal level shifter allows PV_{CC1} to operate at voltages above V_{CC} and PV_{CC} , up to 13V maximum. This higher voltage can be supplied with a separate supply, or it can be generated using a simple charge pump as shown in Figure 4. When using a separate PV_{CC1} supply, the PV_{CC} input may exhibit a large inrush current if PV_{CC1} is present during power up. The 90% maximum duty cycle ensures that the charge pump will always provide sufficient gate drive to M1. Gate drive for the bottom MOSFET M2 is provided through PV_{CC2} for 16-lead devices or V_{CC}/PV_{CC2} for 8-lead devices. PV_{CC2} can usually be driven directly from PV_{CC} with 16-lead parts, although it can also be charge pumped or connected to an alternate supply if desired. The 8-lead parts require an RC filter from PV_{CC} to ensure proper operation; see Input Supply Considerations.

EXTERNAL COMPONENT SELECTION

Power MOSFETs

Two N-channel power MOSFETs are required for most LTC1430 circuits. These should be selected based primarily on threshold and on-resistance considerations; thermal dissipation is often a secondary concern in high

efficiency designs. Required MOSFET threshold should be determined based on the available power supply voltages and/or the complexity of the gate drive charge pump scheme. In 5V input designs where an auxiliary 12V supply is available to power PV_{CC1} and PV_{CC2} , standard MOSFETs with $R_{DS(ON)}$ specified at $V_{GS} = 5V$ or $6V$ can be used with good results. The current drawn from this supply varies with the MOSFETs used and the LTC1430's operating frequency, but is generally less than 50mA.

LTC1430 designs that use a doubler charge pump to generate gate drive for M1 and run from PV_{CC} voltages below 7V cannot provide enough gate drive voltage to fully enhance standard power MOSFETs. When run from 5V, a doubler circuit may work with standard MOSFETs, but the MOSFET R_{ON} may be quite high, raising the dissipation in the FETs and costing efficiency. Logic level FETs are a better choice for 5V PV_{CC} systems; they can be fully enhanced with a doubler charge pump and will operate at maximum efficiency. Doubler designs running from PV_{CC} voltages near 4V will begin to run into efficiency problems even with logic level FETs; such designs should be built with tripler charge pumps (see Figure 5) or with newer, super low threshold MOSFETs. Note that doubler charge pump designs running from more than 7V and all tripler charge pump designs should include a zener clamp diode D_Z at PV_{CC1} to prevent transients from exceeding the absolute maximum rating at that pin.

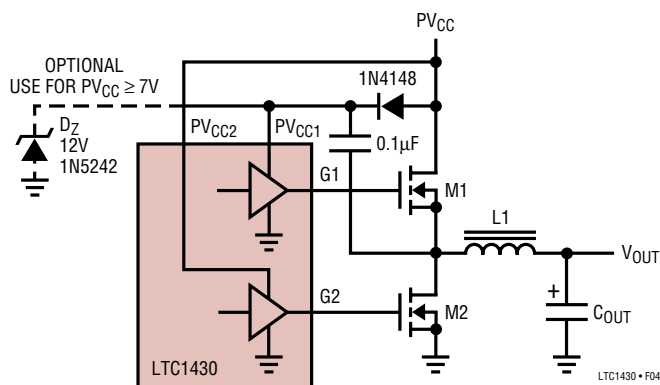

Figure 4. Doubling Charge Pump

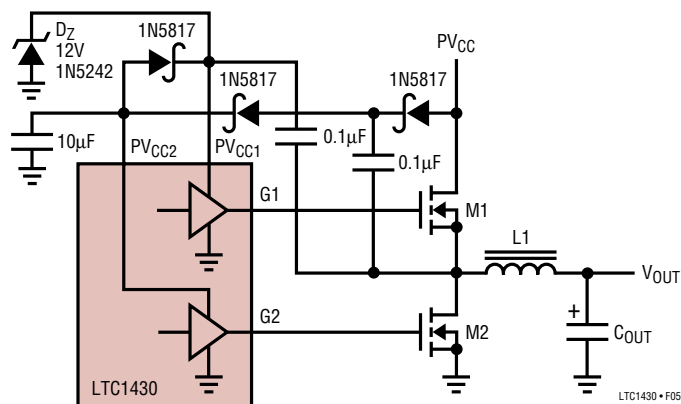

Figure 5. Tripling Charge Pump

APPLICATIONS INFORMATION

Once the threshold voltage has been selected, R_{ON} should be chosen based on input and output voltage, allowable power dissipation and maximum required output current. In a typical LTC1430 buck converter circuit operating in continuous mode, the average inductor current is equal to the output load current. This current is always flowing through either M1 or M2 with the power dissipation split up according to the duty cycle:

$$DC(M1) = \frac{V_{OUT}}{V_{IN}}$$

$$DC(M2) = 1 - \frac{V_{OUT}}{V_{IN}}$$

$$= \frac{(V_{IN} - V_{OUT})}{V_{IN}}$$

The R_{ON} required for a given conduction loss can now be calculated by rearranging the relation $P = I^2R$:

$$R_{ON}(M1) = \frac{P_{MAX}(M1)}{DC(M1) \cdot I_{MAX}^2}$$

$$= \frac{V_{IN} \cdot P_{MAX}(M1)}{V_{OUT} \cdot I_{MAX}^2}$$

$$R_{ON}(M2) = \frac{P_{MAX}(M2)}{DC(M2) \cdot I_{MAX}^2}$$

$$= \frac{V_{IN} \cdot P_{MAX}(M2)}{(V_{IN} - V_{OUT}) \cdot I_{MAX}^2}$$

P_{MAX} should be calculated based primarily on required efficiency. A typical high efficiency circuit designed for 5V in, 3.3V at 10A out might require no more than 3% efficiency loss at full load for each MOSFET. Assuming roughly 90% efficiency at this current level, this gives a P_{MAX} value of $(3.3V \cdot 10A/0.9) \cdot 0.03 = 1.1W$ per FET and a required R_{ON} of:

$$R_{ON}(M1) = \frac{5V \cdot 1.1W}{3.3V \cdot 10A^2} = 0.017\Omega$$

$$R_{ON}(M2) = \frac{5V \cdot 1.1W}{(5V - 3.3V) \cdot 10A^2} = 0.032\Omega$$

Note that the required R_{ON} for M2 is roughly twice that of M1 in this example. This application might specify a single 0.03Ω device for M2 and parallel two more of the same devices to form M1. Note also that while the required R_{ON} values suggest large MOSFETs, the dissipation numbers are only 1.1W per device or less—large TO-220 packages and heat sinks are not necessarily required in high efficiency applications. Siliconix Si4410DY (in SO-8) and Motorola MTD20N03HL (in DPAK) are two small, surface mount devices with R_{ON} values of 0.03Ω or below with 5V of gate drive; both work well in LTC1430 circuits with up to 10A output current. A higher P_{MAX} value will generally decrease MOSFET cost and circuit efficiency and increase MOSFET heat sink requirements.

Inductor

The inductor is often the largest component in an LTC1430 design and should be chosen carefully. Inductor value and type should be chosen based on output slew rate requirements and expected peak current. Inductor value is primarily controlled by the required current slew rate. The maximum rate of rise of the current in the inductor is set by its value, the input-to-output voltage differential and the maximum duty cycle of the LTC1430. In a typical 5V to 3.3V application, the maximum rise time will be:

$$90\% \cdot \frac{(V_{IN} - V_{OUT})}{L} \frac{AMPS}{SECOND} = \frac{1.53A}{\mu s} \frac{1}{L}$$

where L is the inductor value in μH . A $2\mu H$ inductor would have a $0.76A/\mu s$ rise time in this application, resulting in a $6.5\mu s$ delay in responding to a 5A load current step. During this $6.5\mu s$, the difference between the inductor current and the output current must be made up by the output capacitor, causing a temporary droop at the output. To minimize this effect, the inductor value should usually be in the $1\mu H$ to $5\mu H$ range for most typical 5V to 3.3V LTC1430 circuits. Different combinations of input and output voltages and expected loads may require different values.

Once the required value is known, the inductor core type can be chosen based on peak current and efficiency requirements. Peak current in the inductor will be equal to the maximum output load current added to half the peak-to-peak inductor ripple current. Ripple current is set by the

APPLICATIONS INFORMATION

inductor value, the input and output voltage and the operating frequency. If the efficiency is high and can be approximately equal to 1, the ripple current is approximately equal to:

$$\Delta I = \frac{(V_{IN} - V_{OUT})}{f_{OSC} \cdot L} \cdot DC$$

$$DC = \frac{V_{OUT}}{V_{IN}}$$

f_{OSC} = LTC1430 oscillator frequency
L = inductor value

Solving this equation with our typical 5V to 3.3V application, we get:

$$\frac{1.7 \cdot 0.66}{200\text{kHz} \cdot 2\mu\text{H}} = 2.8\text{A}_{P-P}$$

Peak inductor current at 10A load:

$$10\text{A} + \frac{2.8\text{A}}{2} = 11.4\text{A}$$

The inductor core must be adequate to withstand this peak current without saturating, and the copper resistance in the winding should be kept as low as possible to minimize resistive power loss. Note that the current may rise above this maximum level in circuits under current limit or under fault conditions in unlimited circuits; the inductor should be sized to withstand this additional current.

Input and Output Capacitors

A typical LTC1430 design puts significant demands on both the input and output capacitors. Under normal steady load operation, a buck converter like the LTC1430 draws square waves of current from the input supply at the switching frequency, with the peak value equal to the output current and the minimum value near zero. Most of this current must come from the input bypass capacitor, since few raw supplies can provide the current slew rate to feed such a load directly. The resulting RMS current flow in the input capacitor will heat it up, causing premature capacitor failure in extreme cases. Maximum RMS current occurs with 50% PWM duty cycle, giving an RMS current

value equal to $I_{OUT}/2$. A low ESR input capacitor with an adequate ripple current rating must be used to ensure reliable operation. Note that capacitor manufacturers' ripple current ratings are often based on only 2000 hours (3 months) lifetime; further derating of the input capacitor ripple current beyond the manufacturer's specification is recommended to extend the useful life of the circuit.

The output capacitor in a buck converter sees much less ripple current under steady-state conditions than the input capacitor. Peak-to-peak current is equal to that in the inductor, usually a fraction of the total load current. Output capacitor duty places a premium not on power dissipation but on ESR. During an output load transient, the output capacitor must supply all of the additional load current demanded by the load until the LTC1430 can adjust the inductor current to the new value. ESR in the output capacitor results in a step in the output voltage equal to the ESR value multiplied by the change in load current. A 5A load step with a 0.05 Ω ESR output capacitor will result in a 250mV output voltage shift; this is a 7.6% output voltage shift for a 3.3V supply! Because of the strong relationship between output capacitor ESR and output load transient response, the output capacitor is usually chosen for ESR, not for capacitance value; a capacitor with suitable ESR will usually have a larger capacitance value than is needed to control steady-state output ripple.

Electrolytic capacitors rated for use in switching power supplies with specified ripple current ratings and ESR can be used effectively in LTC1430 applications. OS-CON electrolytic capacitors from Sanyo give excellent performance and have a very high performance/size ratio for an electrolytic capacitor. Surface mount applications can use either electrolytic or dry tantalum capacitors. Tantalum capacitors must be surge tested and specified for use in switching power supplies; low cost, generic tantalums are known to have very short lives followed by explosive deaths in switching power supply applications. AVX TPS series surface mount devices are popular tantalum capacitors that work well in LTC1430 applications. A common way to lower ESR and raise ripple current capability is to parallel several capacitors. A typical LTC1430 application might require an input capacitor with a 5A ripple current capacity and 2% output shift with a 10A output load step, which requires a 0.007 Ω output capacitor ESR. Sanyo

APPLICATIONS INFORMATION

OS-CON part number 10SA220M (220 μ F/10V) capacitors feature 2.3A allowable ripple current at 85°C and 0.035 Ω ESR; three in parallel at the input and six at the output will meet the above requirements.

Input Supply Considerations/Charge Pump

The 16-lead LTC1430 requires four supply voltages to operate: PV_{CC} for the main power input, PV_{CC1} and PV_{CC2} for MOSFET gate drive and a clean, low ripple V_{CC} for the LTC1430 internal circuitry (Figure 6). In many applications, PV_{CC} and PV_{CC2} can be tied together and fed from a common high power supply, provided that the supply voltage is high enough to fully enhance the gate of external MOSFET M2. This can be the 5V system supply if a logic level MOSFET is used for M2. V_{CC} can usually be filtered with an RC from this same high power supply; the low quiescent current (typically 350 μ A) allows the use of relatively large filter resistors and correspondingly small filter capacitors. 100 Ω and 4.7 μ F usually provide adequate filtering for V_{CC} .

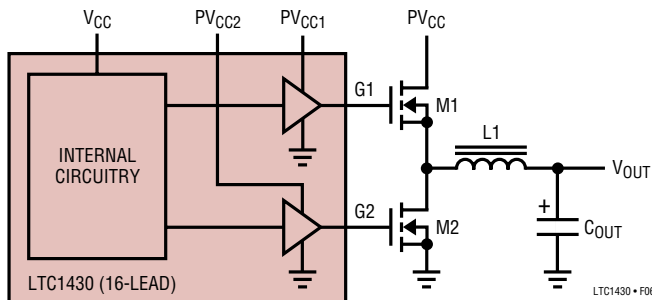

Figure 6. 16-Lead Power Supplies

The 8-lead versions of the LTC1430 have the PV_{CC2} and V_{CC} pins tied together inside the package (Figure 7). This pin, brought out as V_{CC}/PV_{CC2} , has the same low ripple requirements as the 16-lead part, but must also be able to supply the gate drive current to M2. This can be obtained by using a larger RC filter from the PV_{CC} pin; 22 Ω and 10 μ F work well here. The 10 μ F capacitor must be VERY close to the part (preferably right underneath the unit) or output regulation may suffer.

For both versions of the LTC1430, PV_{CC1} must be higher than PV_{CC} by at least one external MOSFET $V_{GS(ON)}$ to fully enhance the gate of M1. This higher voltage can be provided with a separate supply (typically 12V) which should power up after PV_{CC} , or it can be generated with a simple charge pump (Figure 4). The charge pump consists of a 1N4148 diode from PV_{CC} to PV_{CC1} and a 0.1 μ F capacitor from PV_{CC1} to the switching node at the drain of M2. This circuit provides $2PV_{CC} - V_F$ to PV_{CC1} while M1 is ON and $PV_{CC} - V_F$ while M1 is OFF where V_F is the ON voltage of the 1N4148 diode. Ringing at the drain of M2 can cause transients above $2PV_{CC}$ at PV_{CC1} ; if PV_{CC} is higher than 7V, a 12V zener diode should be included from PV_{CC1} to PGND to prevent transients from damaging the circuitry at PV_{CC2} or the gate of M1.

More complex charge pumps can be constructed with the 16-lead versions of the LTC1430 to provide additional voltages for use with standard threshold MOSFETs or very low PV_{CC} voltages. A tripling charge pump (Figure 5) can provide $2PV_{CC}$ and $3PV_{CC}$ voltages. These can be connected to PV_{CC2} and PV_{CC1} respectively, allowing standard threshold MOSFETs to be used with 5V at PV_{CC} or 5V logic level threshold MOSFETs to be used with 3.3V at PV_{CC} . V_{CC} can be driven from the same potential as PV_{CC2} , allowing the entire system to run from a single 3.3V supply. Tripling charge pumps require the use of Schottky diodes to minimize forward drop across the diodes at start-up. The tripling charge pump circuit will tend to rectify any ringing at the drain of M2 and can provide well more than $3PV_{CC}$ at PV_{CC1} ; all tripling (or higher multiplying factor) circuits should include a 12V zener clamp diode D_Z to prevent overvoltage at PV_{CC1} .

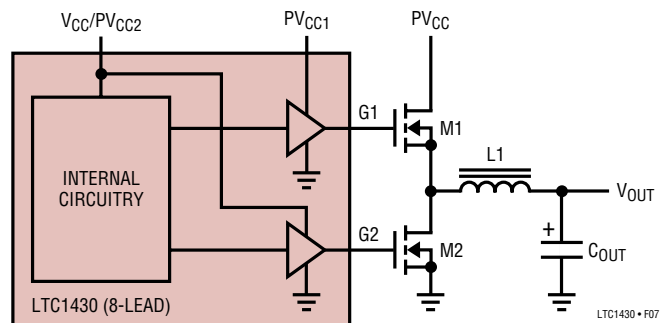

Figure 7. 8-Lead Power Supplies

APPLICATIONS INFORMATION

Compensation and Transient Response

The LTC1430 voltage feedback loop is compensated at the COMP pin; this is the output node of the internal g_m error amplifier. The loop can generally be compensated properly with an RC network from COMP to GND and an additional small C from COMP to GND (Figure 8). Loop stability is affected by inductor and output capacitor values and by other factors. Optimum loop response can be obtained by using a network analyzer to find the loop poles and zeros; nearly as effective and a lot easier is to empirically tweak the R_C values until the transient recovery looks right with an output load step. Table 1 shows recommended compensation components for 5V to 3.3V applications based on the inductor and output capacitor values. The values were calculated using multiple paralleled 330 μ F AVX TPS series surface mount tantalum capacitors as the output capacitor.

Table 1. Recommended Compensation Network for 5V to 3.3V Application Using Multiple 330 μ F AVX Output Capacitors

L1 (μ H)	C _{OUT} (μ F)	R _C (k Ω)	C _C (μ F)	C1 (pF)
1	990	1.8	0.022	820
1	1980	3.6	0.01	470
1	4950	9.1	0.0047	150
1	9900	18	0.0022	82
2.7	990	3.6	0.01	470
2.7	1980	7.5	0.0047	220
2.7	4950	18	0.0022	82
2.7	9900	39	0.001	39
5.6	990	9.1	0.0047	150
5.6	1980	18	0.0022	82
5.6	4950	47	820pF	33
5.6	9900	91	470pF	15
10	990	18	0.0022	82
10	1980	39	0.001	39
10	4950	91	470pF	15
10	9900	180	220pF	10

Output transient response is set by three major factors: the time constant of the inductor and the output capacitor, the more impact on overall transient recovery time than the third; unless the loop compensation is way off, more improvement can be had by optimizing the inductor and the output capacitor than by fiddling with the loop com-

pensation components. In general, a smaller value inductor will improve transient response at the expense of ripple and inductor core saturation rating. Minimizing output capacitor ESR will also help optimize output transient response. See Input and Output Capacitors for more information.

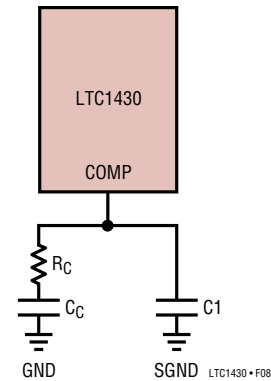

Figure 8. Compensation Pin Hook-Up

Soft-Start and Current Limit

The 16-lead versions of the LTC1430 include a soft-start circuit at the SS pin; this circuit is used both for initial start-up and during current limit operation. The soft-start and current limit circuitry is disabled in 8-lead versions. SS requires an external capacitor to GND with the value determined by the required soft-start time. An internal 12 μ A current source is included to charge the external capacitor. Soft-start functions by clamping the maximum voltage that the COMP pin can swing to, thereby controlling the duty cycle (Figure 9). The LTC1430 will begin to operate at low duty cycle as the SS pin rises to about 2V below V_{CC} . As SS continues to rise, the duty cycle will increase until the error amplifier takes over and begins to regulate the output. When SS reaches 1V below V_{CC} the LTC1430 will be in full operation. An internal switch shorts the SS pin to GND during shutdown.

The LTC1430 detects the output current by watching the voltage at I_{FB} while M1 is ON. The I_{LIM} amplifier compares this voltage to the voltage at I_{MAX} (Figure 10). In the ON state, M1 has a known resistance; by calculating backwards, the voltage generated at I_{FB} by the maximum output current in M1 can be determined. As I_{FB} falls below I_{MAX} , I_{LIM} will begin to sink current from the soft-start pin,

APPLICATIONS INFORMATION

causing the voltage at SS to fall. As SS falls, it will limit the output duty cycle, limiting the current at the output. Eventually the system will reach equilibrium, where the pull-up current at the SS pin matches the pull-down current in the I_{LIM} amplifier; the LTC1430 will stay in this state until the overcurrent condition disappears. At this time I_{FB} will rise, I_{LIM} will stop sinking current and the internal pull-up will recharge the soft-start capacitor, restoring normal operation. Note that the I_{FB} pin requires an external 1k series resistor to prevent voltage transients at the drain of M2 from damaging internal structures.

The I_{LIM} amplifier pulls current out of SS in proportion to the difference between I_{FB} and I_{MAX} . Under mild overload conditions, the SS pin will fall gradually, creating a time delay before current limit takes effect. Very short, mild overloads may not trip the current limit circuit at all. Longer overload conditions will allow the SS pin to reach a steady level, and the output will remain at a reduced voltage until the overload is removed. Serious overloads will generate a larger overdrive at I_{LIM} , allowing it to pull SS down more quickly and preventing damage to the output components.

The I_{LIM} amplifier output is disabled when M1 is OFF to prevent the low I_{FB} voltage in this condition from activating the current limit. It is re-enabled a fixed 170ns after M1

turns on; this allows for the I_{FB} node to slew back high and the I_{LIM} amplifier to settle to the correct value. As the LTC1430 goes deeper into current limit, it will reach a point where the M1 on-time needs to be cut to below 170ns to control the output current. This conflicts with the minimum settling time needed for proper operation of the I_{LIM} amplifier. At this point, a secondary current limit circuit begins to reduce the internal oscillator frequency, lengthening the off-time of M1 while the on-time remains constant at 170ns. This further reduces the duty cycle, allowing the LTC1430 to maintain control over the output current.

Under extreme output overloads or short circuits, the I_{LIM} amplifier will pull the SS pin more than 2V below V_{CC} in a single switching cycle, cutting the duty cycle to zero. At this point all switching stops, the output current decays through M2 and the LTC1430 runs a partial soft-start cycle and restarts. If the short is still present the cycle will repeat. Peak currents can be quite high in this condition, but the average current is controlled and a properly designed circuit can withstand short circuits indefinitely with only moderate heat rise in the output FETs. In addition, the soft-start cycle repeat frequency can drop into the low kHz range, causing vibrations in the inductor which provide an audible alarm that something is wrong.

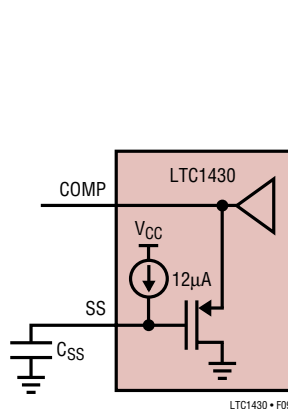

Figure 9. Soft-Start Clamps COMP Pin

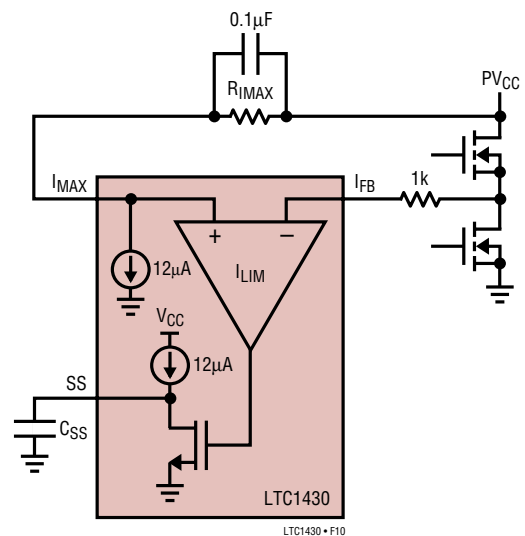

Figure 10. Current Limit Operation

APPLICATIONS INFORMATION

Oscillator Frequency

The LTC1430 includes an onboard current controlled oscillator which will typically free-run at 200kHz. An internal 20 μ A current is summed with any current in or out of the FREQSET pin (pin 11), setting the oscillator frequency to approximately 10kHz/ μ A. FREQSET is internally servoed to the LTC1430 reference voltage (1.26V). With FREQSET floating, the oscillator is biased from the internal 20 μ A source and runs at 200kHz. Connecting a 50k resistor from FREQSET to ground will sink an additional 25 μ A from FREQSET, causing the internal oscillator to run at approximately 450kHz. Sourcing an external 10 μ A current into FREQSET will cut the internal frequency to 100kHz. An internal clamp prevents the oscillator from running slower than about 50kHz. Tying FREQSET to V_{CC} will cause it to run at this minimum speed.

Shutdown

The LTC1430 includes a low power shutdown mode, controlled by the logic at the SHDN pin. A high at SHDN allows the part to operate normally. A low level at SHDN stops all internal switching, pulls COMP and SS to ground internally and turns M1 and M2 off. In shutdown, the LTC1430 itself will drop below 1 μ A quiescent current typically, although off-state leakage in the external MOSFETs may cause the total PV_{CC} current to be somewhat higher, especially at elevated temperatures. When SHDN rises again, the LTC1430 will rerun a soft-start cycle and resume normal operation. Holding the LTC1430 in shutdown during PV_{CC} power up removes any PV_{CC1} sequencing constraints.

LAYOUT CONSIDERATIONS

Grounding

Proper grounding is critical for the LTC1430 to obtain specified output regulation. Extremely high peak currents (as high as several amps) can flow between the bypass capacitors and the PV_{CC1} , PV_{CC2} and PGND pins. These currents can generate significant voltage differences between two points that are nominally both “ground.” As a general rule, GND and PGND should be totally separated on the layout, and should be brought together at only one

point, right at the LTC1430 GND and PGND pins. This helps minimize internal ground disturbances in the LTC1430 by keeping PGND and GND at the same potential, while preventing excessive current flow from disrupting the operation of the circuits connected to GND. The PGND node should be as compact and low impedance as possible, with the negative terminals of the input and output capacitors, the source of M2, the LTC1430 PGND node, the output return and the input supply return all clustered at one point. Figure 11 is a modified schematic showing the common connections in a proper layout. Note that at 10A current levels or above, current density in the PC board itself can become a concern; traces carrying high currents should be as wide as possible.

Output Voltage Sensing

The LTC1430 provides three pins for sensing the output voltage: SENSE⁺, SENSE⁻ and FB. SENSE⁺ and SENSE⁻ connect to an internal resistor divider which is connected to FB. To set the output of the LTC1430 to 3.3V, connect SENSE⁺ to the output as near to the load as practical and connect SENSE⁻ to the common GND/PGND point. Note that SENSE⁻ is not a true differential input sense input; it is just the bottom of the internal divider string. Connecting SENSE⁻ to the ground near the load will not improve load regulation. For any other output voltage, the SENSE⁺ and SENSE⁻ pins should be floated and an external resistor string should be connected to FB (Figure 12). As before, connect the top resistor (R1) to the output as close to the load as practical and connect the bottom resistor (R2) to the common GND/PGND point. In both cases, connecting the top of the resistor divider (either SENSE⁺ or R1) close to the load can significantly improve load regulation by compensating for any drops in PC traces or hookup wires between the LTC1430 and the load.

Power Component Hook-Up/Heat Sinking

As current levels rise much above 1A, the power components supporting the LTC1430 start to become physically large (relative to the LTC1430, at least) and can require special mounting considerations. Input and output capacitors need to carry high peak currents and must have low ESR; this mandates that the leads be clipped as short as possible and PC traces be kept wide and short. The

APPLICATIONS INFORMATION

power inductor will generally be the most massive single component on the board; it can require a mechanical hold-down in addition to the solder on its leads, especially if it is a surface mount type.

The power MOSFETs used require some care to ensure proper operation and reliability. Depending on the current levels and required efficiency, the MOSFETs chosen may be as large as TO-220s or as small as SO-8s. High efficiency circuits may be able to avoid heat sinking the power devices, especially with TO-220 type MOSFETs. As an example, a 90% efficient converter working at a steady 3.3V/10A output will dissipate only $(33W/90\%) \cdot 10\% = 3.7W$. The power MOSFETs generally account for the

majority of the power lost in the converter; even assuming that they consume 100% of the power used by the converter, that's only 3.7W spread over two or three devices. A typical SO-8 MOSFET with a R_{ON} suitable to provide 90% efficiency in this design can commonly dissipate 2W when soldered to an appropriately sized piece of copper trace on a PC board. Slightly less efficient or higher output current designs can often get by with standing a TO-220 MOSFET straight up in an area with some airflow; such an arrangement can dissipate as much as 3W without a heat sink. Designs which must work in high ambient temperatures or which will be routinely overloaded will generally fare best with a heat sink.

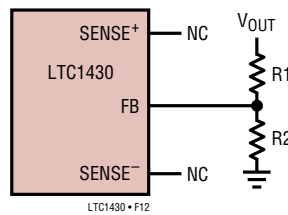

Figure 12. Using External Resistors to Set Output Voltages

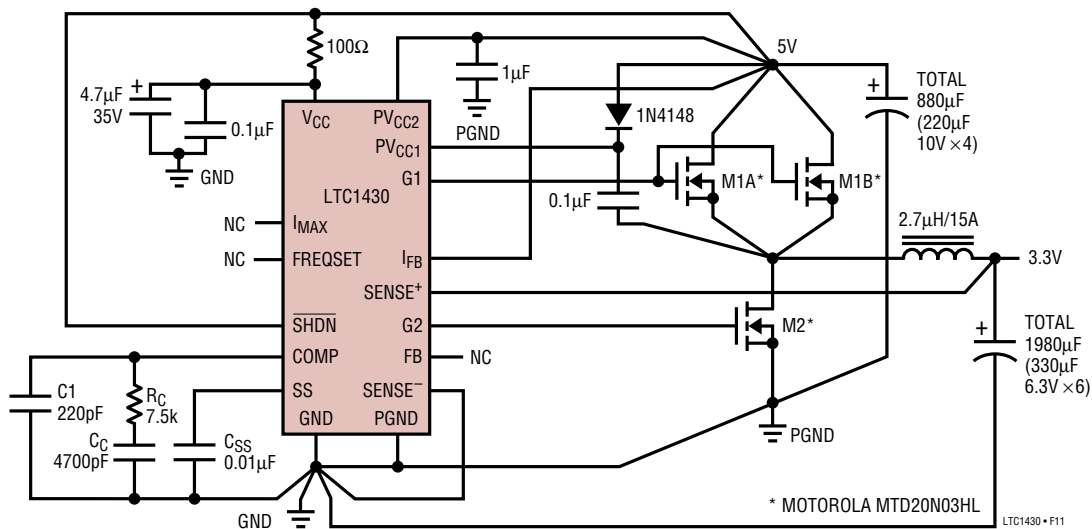
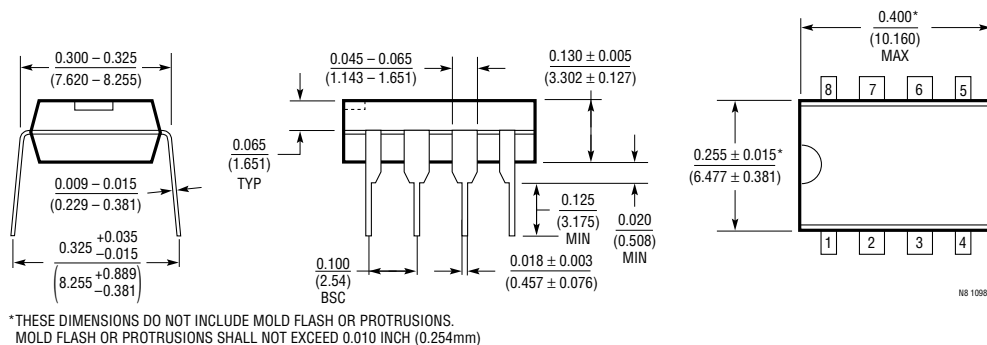

Figure 11. Typical Schematic Showing Layout Considerations

PACKAGE DESCRIPTION

Dimensions in inches (millimeters) unless otherwise noted.

N8 Package
8-Lead PDIP (Narrow 0.300)
 (LTC DWG # 05-08-1510)



N Package
14-Lead PDIP (Narrow 0.300)
 (LTC DWG # 05-08-1510)

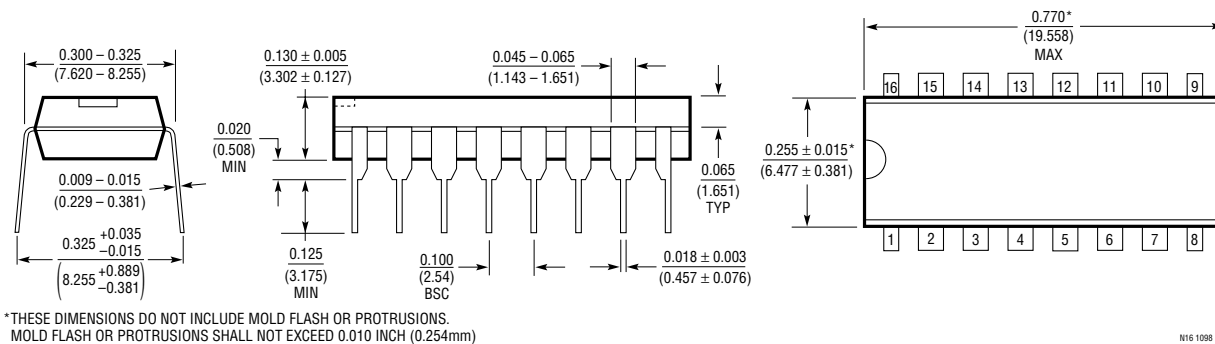

PACKAGE DESCRIPTION

Dimensions in inches (millimeters) unless otherwise noted.

S8 Package
8-Lead Plastic Small Outline (Narrow 0.150)
 (LTC DWG # 05-08-1610)

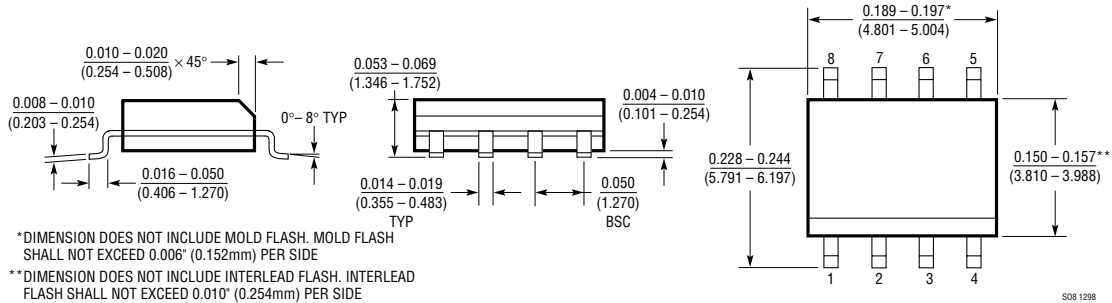

S Package
16-Lead Plastic Small Outline (Narrow 0.150)
 (LTC DWG # 05-08-1610)

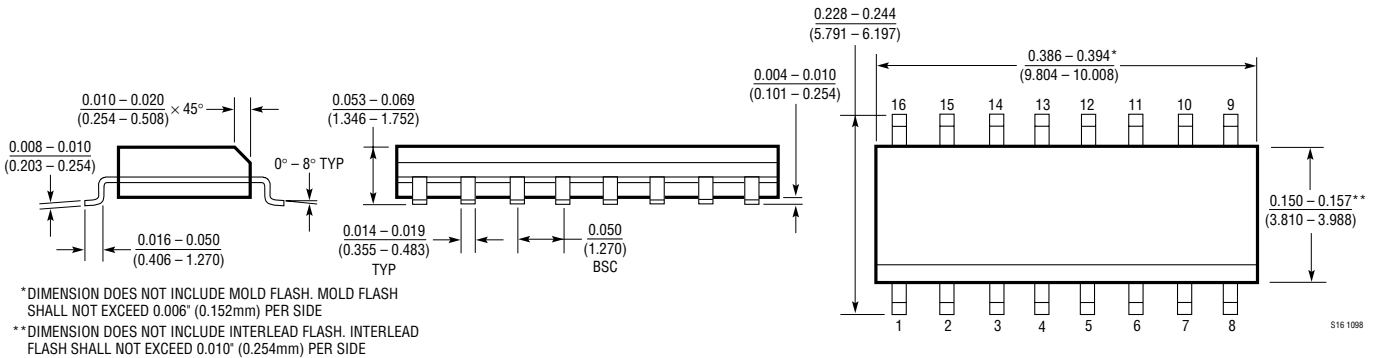

RELATED PARTS

PART NUMBER	DESCRIPTION	COMMENTS
LTC1530	High Power Synchronous Step-Down Controller	SO-8 with Current Limit. No R _{SENSE} Required
LTC1625	No R _{SENSE} [™] Current Mode Synchronous Step-Down Controller	Above 95% Efficiency, Needs No R _{SENSE} , 16-Lead SSOP Package Fits SO-8 Footprint
LTC1628	Dual High Efficiency 2-Phase Synchronous Step-Down Controller	Constant Frequency, Standby 5V and 3.3V LDOs, 3.5V ≤ V _{IN} ≤ 36V
LTC1703	Dual 550kHz Synchronous 2-Phase Switching Regulator Controller with Mobile VID	LTC1702 with 5-Bit Mobile VID for Mobile Pentium® Processor Systems
LTC1706-81	VID Voltage Programmer	Adds 5-Bit Mobile VID to 0.8V Referenced Switching Regulators
LTC1709	2-Phase, 5-Bit Desktop VID Synchronous Step-Down Controller	Current Mode, V _{IN} to 36V, I _{OUT} Up to 42A
LTC1736	Synchronous Step-Down Controller with 5-Bit Mobile VID Control	Fault Protection, PowerGood, 3.5V to 36V Input, Current Mode
LTC1753	5-Bit Desktop VID Programmable Synchronous Switching Regulator	1.3V to 3.5V Programmable Output Using Internal 5-Bit DAC
LTC1873	Dual Synchronous Switching Regulator with 5-Bit Desktop VID	1.3V to 3.5V Programmable Core Output Plus I/O Output
LTC1929	2-Phase, Synchronous High Efficiency Converter	Current Mode Ensures Accurate Current Sensing, V _{IN} Up to 36V, I _{OUT} Up to 40A

No R_{SENSE} is a trademark of Linear Technology Corporation. Pentium is a registered trademark of Intel Corporation.